



# **Grid Connected Hybrid Solar System with MPPT Charge Controller**

A thesis submitted to the Department of Electrical & Electronics Engineering,  
BRAC University in partial fulfillment of the requirement for the Bachelor of  
Science degree in Electrical & Electronics Engineering

By

Azfarul Islam (12121126)

Saraf Wamia Protity (12121064)

Asif Azam (11221011)

# Declaration

We hereby declare that the thesis titled “Grid Connected Hybrid Solar System with MPPT Charge Controller” submitted to the Department of Electrical & Electronics of BRAC University in partial fulfillment of the Bachelor of Science in Electrical & Electronics Engineering. This is our original work and was not submitted elsewhere for the award of any other degree or any other publication.

Date: 16<sup>th</sup> August, 2016

Supervisor

Avijit Das

Co supervisor

Shoilie Chakma

Azfarul Islam (12121126)

Saraf Wamia Protity (12121064)

Asif Azam (11221011)

# **Acknowledgement**

We would like to give our heartiest acknowledgement to our supervisor, Mr. Avijit Das and Co-supervisor Ms. Shoilie Chakma. We are grateful to them for their relentless support, guidance and advice. They helped us with fresh innovative ideas, inspired us and pushed us to think and work beyond our comfort zone. Without their help, the completion of this project would not have been possible.

We are indebted to Mr. Mainul Islam, the owner of Bangladesh Electronics and Advanced Technology Solutions (BEATS). He helped us to carry out our work with his support each and every day. He provided the equipment required for our project.

Finally, we would like to thank our respective families for their constant encouragement and support.

# **Abstract**

The main work of our thesis is based on a charge controller that tracks the maximum power from the solar panel. This is done with the help of an algorithm (Perturb & Observe) and send that power to our respective load. The aim was to attempt to make a Hybrid system which in other words means incorporation of solar and grid system and making them work simultaneously. Our objective was to create efficient and effective Hybrid system which could be used for both residential and industrial purpose so that it is cost effective and promotes high usage of green energy.

# Table of Contents

Cover Page.....	i
Declaration.....	ii
Acknowledgement.....	iii
Abstract.....	iv
Table of Content.....	v
Figure list.....	vi

## Chapter 1

1.1 Introduction.....	1
1.2 PV Cells.....	2
1.3 I-V Characteristics of PV cells.....	3

## Chapter 2

2.1 Basic Principle of PV System.....	5
2.2 Charge Controller.....	5
2.3 Maximum Power Point Tracking (MPPT).....	6
2.3.1 Short-Current Pulse Method.....	7
2.3.2 Temperature Method.....	7
2.3.3 Incremental Conductance.....	8
2.3.4 Perturb & Observe Method.....	10
2.4 MPPT vs PWM.....	11

2.5 Hybrid System.....12

    2.5.1 Advantages of Hybrid System.....13

**Chapter 3**

3.1 Components.....14

3.2 Working Procedure of MPPT Charge  
Controller.....15

    3.2.1 At a glance.....15

    3.2.2 Algorithm.....17

    3.2.3 Buck Converter.....18

    3.2.4 Working Principle of Buck Converter.....19

    3.2.5 Working Principle of MOSFET Gate driver.....19

    3.2.6 Circuit diagram for MPPT Charge Controller.....21

    3.2.7 Working procedure of diode switching module.....25

**Chapter 4**

4.1 Result.....28

4.2 I-V & P-V graphs of 100W Solar Panel.....28

4.3 Fill Factor.....32

4.4 Billing and Savings.....32

4.5 Installation cost.....34

**Chapter 5**

5.1 Conclusion and future aspects.....35

References.....36

# Figure list

Fig 1.1: I-V characteristics of a PV cell.....	04
Fig 1.2: P-V characteristics of a PV cell.....	04
Fig 2.1: Flowchart of Incremental Conductance Method .....	09
Fig 2.2: Flowchart of perturb and observe.....	10
Fig 2.3: Block Diagram of Hybrid System.....	12
Fig 3.1 MPPT charge controller.....	16
Fig 3.2 Diode Switching Module.....	16
Fig 3.3 Schematic of a buck converter circuit.....	18
Fig 3.4 MOSFET Gate driver circuit diagram.....	19
Fig 3.5 MPPT charge controller circuit diagram.....	21
Fig 3.6 PCB layout MPPT charge controller.....	22
Fig 3.7 Diode switching module schematic.....	25
Fig 3.8 Diode switching module PCB layout.....	26
Fig 4.1 I-V curve and P-V curve.....	29
Fig 4.2 I-V curve and P-V curve.....	30
Fig 4.3 I-V curve and P-V curve.....	31



# List of tables

Table 4.1 Fill Factor Calculations.....32

Table 4.2: Billing of 210 bulbs over a month.....33

# Chapter-1

## 1.1 Introduction

Among the numerous resources available in our galaxy, the sun provides the cleanest, most consistent and infinitely abundant of it in the form of solar energy. With the ever growing technologies many ways have been obtained to harness the power from the sun- photovoltaic, solar heating, solar thermal energy, etc.

The importance of solar energy goes back to the times of early civilization of mankind. It was used for warming homes, drying clothes and also sometimes food (it is still used in the rural areas of south-east Asia). However, now that we know that there is more than just warmth that we can get from the sun it seems prudent to utilize maximum of this resource, particularly because it has no limit in supply. Since the beginning of modernization the major source of energy used has been fossil fuel. While it helped building the new world that we reside in tremendously and effectively no doubt, nonetheless, it cost the world more than we ever accounted for. The largest and most catastrophic of these costs would be global warming which is not only destroying the Earth's environment but also giving rise to major natural calamities.

The dilemma does not end there. The continuous usage of fossil fuels has lead to nearly depleting the stock that our planet has. This is where solar energy comes into play. Although there is still room for efficiency in terms of getting end result, it is still a wise path because of its abundant availability and it does zero damage to the environment.

Bangladesh is situated near the equator and therefore has receives a huge proportion of this sustainable energy. At this point the most appropriate form of renewable energy is Solar

Photovoltaic (PV) system, regardless of the monsoon climate in our country [2].

Our country has been facing crisis for power generation for over a decade now. This is mostly due to the insufficient capacity of power generation in comparison to the rising demand and ageing infrastructure of several present power generation facilities. Of the total population of Bangladesh, 80% lives in rural areas and of which a mere 10% receives electricity [3]. Hence, an attractive use of PV system was introduced known as the solar home system (SHS), which is mostly used for lighting system. From October 2004 to December 2004 six case analyses were collected from the district Gazipur, Bangladesh, to see the sustainability of this system. The study showed that SHS is financially attractive for household lighting with entertainment and for small rural business [2].

## 1.2 PV Cells

The two most common ways to convert solar energy into electrical energy are- *solar thermal* and *solar photovoltaic*.

- Solar Thermal: it is almost similar to the generation of traditional AC generation by steam turbine, but the only difference is instead of fossil fuel it extracts heat from concentrated solar ray. This heat is used to produce steam and is kept in thermally insulated tanks and is used during intervals of sunlight or at night.
- Solar Photovoltaic: it use cells that are made up of some sort of semiconductor materials mostly silicon that absorbs energy from incident sunshine in DC electricity. To make up for night time or when there is an intermittency of sunlight, the energy generated is required to be stored into a battery.

### 1.3 I-V Characteristics of PV Cells

To obtain the current-voltage (I-V) curves the cell needs to be exposed constantly to sunlight, at the same time maintain the cell temperature, vary the load resistance and measure the current produced. The curve passes through two points:  $I_{SC}$  and  $V_{OC}$ .

- $I_{SC}$ - short-circuit current: this current is produced when the negative and the positive terminals of the cell gets short-circuited and the terminal voltage becomes zero that results into a zero load.
- $V_{SC}$ - open-circuit voltage: it is the voltage across the negative and positive terminal of the cell when it is open-circuited and the current is zero that results into infinite load resistance.

The cell can be operated by varying the load resistance within a wide range from zero (short-circuit) to infinity (open-circuit) and the MPP point can be tracked. The maximum power point ( $P_m$ ) on the curve occurs when the current and voltage product is highest. There is zero power on the short-circuit point and on the open-circuit point. This means MPP lies somewhere between these two points. At the “knee” point of the curve the maximum power lies as well as the maximum efficiency <sup>[4]</sup>.

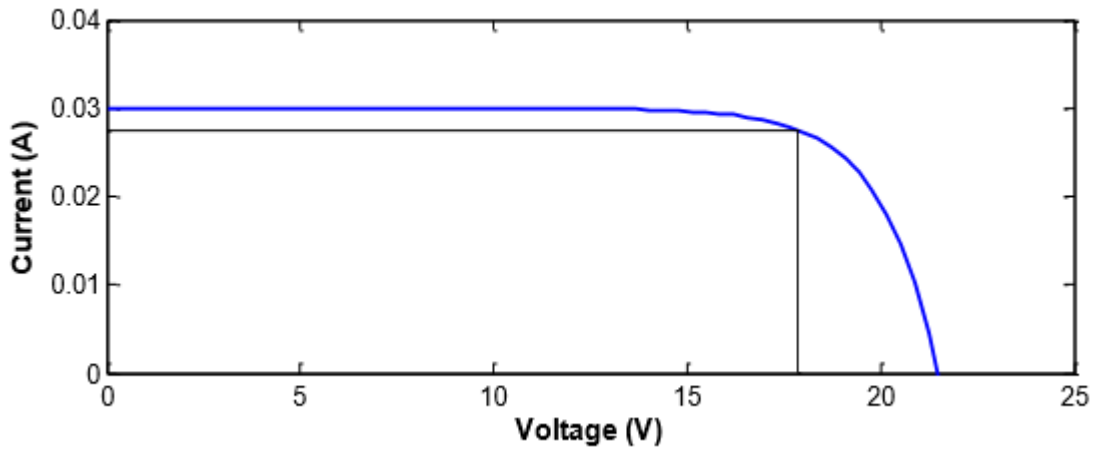

Fig 1.1: I-V characteristics of a PV cell

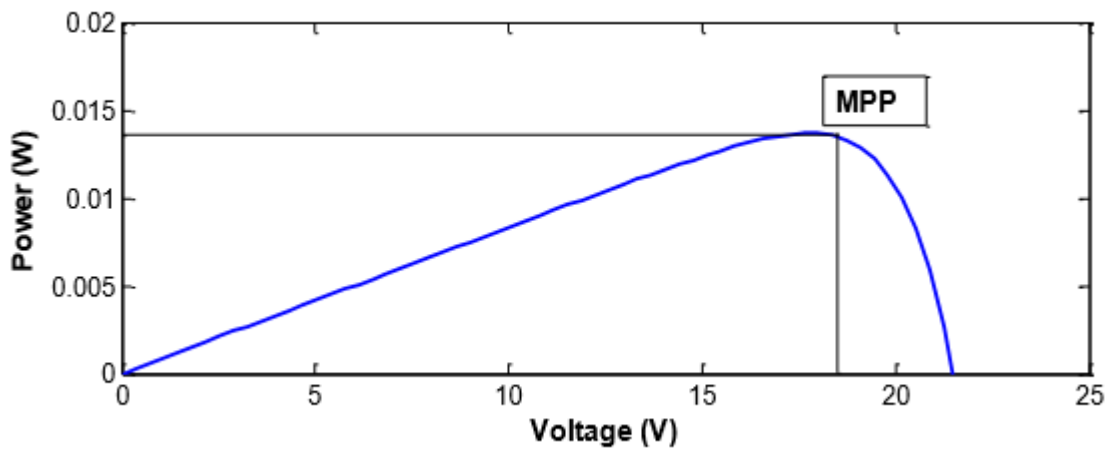

Fig 1.2: P-V characteristics of a PV cell

# **Chapter-2**

## **2.1 Basic Principle of PV System**

The procedure that we followed is being shortly discussed here. The input is taken from PV panels and is then send to the MPPT charge controller. At the output terminal a battery is connected, the MPPT sends a low current output digital signal that is amplified with the inductor in a DC-DC converter (Buck) which is then send to the battery. A load is connected in parallel to the battery.

## **2.2 Charge Controller**

A charge controller controls the rate at which electric current enters or exits electric batteries. It prevents complete drainage of a battery or performs controlled discharge, relying on the battery technology, to increase the lifespan of the battery. Charge controllers are often called solar regulators in solar applications.

Series charge controller or series regulator ensures no further charge flows to the battery when they are fully charged. A shunt controller redirects the excess electricity to an auxiliary load such as- electric water heater, when battery is full. Charge controllers sometimes check battery temperature to prevent it from overheat, displays data, transmits data to displays that are remote, etc.

The necessity of the charge controller in our system is very crucial. It ensures that the battery remains at the highest possible state of charge. When battery is charged from the PV module, the charge controller prevents the battery from overcharging and at the same time disconnects

load to protect it from rapid discharging. If there is no charge controller, current will flow into the battery in proportion to the level of irradiance regardless of the charging requirements of the battery.

In order for a charge controller to work certain algorithm needs to be incorporated in it to obtain the maximum operating point.

## **2.3 Maximum Power Point Tracking (MPPT)**

A MPPT is basically a DC to DC converter (electrical). This technique is mostly operated with solar array (PV panels) and few wind turbines to obtain maximum power transmission and convert it to match with whatever load it is being connected to- utility grid, battery bank or any other load. The most common difficulty of MPPT is that its efficiency varies with the amount of sunlight. When the amount of sunlight falling on the panel changes, the characteristics of the load changes to a point where the system can get maximum power efficiency. The function of MPPT is to locate this load point and maintain the power transfer to optimum and this load is called *maximum power point*.

There are several kinds of MPPT methods, of them most commonly used and direct methods are the Perturb and Observe Method and Incremental Conductance Method. However, there are several other methods that are indirect and are considered quite inaccurate at times.

### **2.3.1 Short-Current Pulse Method:**

In this method, MPP is obtained by generating an operating current ( $I_{op}$ ) to a current controlled power converter. Under various situation of irradiance level ( $S$ ), the optimum operating current is proportional to the short circuit current ( $I_{sc}$ ) for maximum power output-

$$I_{op} (S) = k \cdot I_{sc} (S) \quad [1.2]$$

here  $k$  is the proportionality constant. Equation 1.2 shows that if  $I_{sc}$  is detected then  $I_{op}$  can be determined instantaneously, regardless of any temperature changes (temperature usually varies from  $0^{\circ}\text{C}$ - $60^{\circ}\text{C}$ ). The proportionality is approximately estimated to 92%.

So, the measurement of  $I_{sc}$  is required for this control algorithm and to obtain that a static switch is connected to the PV arrays in parallel to create short-circuit. During this short-circuit, PV array voltage ( $V_{pv}$ ) is zero also the PV system neither supplies and power nor generates any energy.

### **2.3.2 Temperature Method:**

The short-circuit current is directly proportional to the irradiance level regardless of what the temperature is, whereas, the open-circuit voltage ( $V_{oc}$ ) of the solar cell mainly changes with the temperature of the cell. This can be shown by the equation-

$$V_{ov} \approx V_{ovSTC} + (dV_{ov}/dT) \cdot (T - T_{STC}) \quad [1.3]$$

Here  $V_{ovSTC}$  is the open-circuit voltage for Standard Test Conditions (STC), the  $T_{STC}$  is the temperature at STC and  $dV_{ov}/dT$  is the rate of voltage change against change of temperature or temperature gradient. The optimal voltage meanwhile can be shown by the following equation-



$$V_{op} \approx [(u+S.v)-T(w+S.y)].V_{MPP\_STC} \quad [1.4]$$

here  $V_{MPP\_STC}$  is the MPP voltage at STC.

In literature, there are two different types of method obtainable. They are-

*The Temperature Gradient method (TG):* In this algorithm obtaining the open-circuit voltage depends on the temperature under STC, from equation 1.3 the optimal value for the open-circuit voltage is obtained by ignoring power losses. The Temperature Gradient (TG) entails the value of the temperature and the value of the  $V_{PV}$  for the PI regulator.

*The Temperature Parametric Equation method (TP):* this algorithm takes into account equation 1.4 and decides the value of the optimum operating voltage  $V_{op}$  immediately by measuring S and T. Generally, this method also requires the measurement of the solar irradiance.

## **The two direct method**

### **2.3.3 Incremental Conductance**

The Incremental Conductance (IC) algorithm is based on the following equation of MPP-

$$(dI_{PV}/dV_{PV}) + (I_{PV}/V_{PV})= 0 \quad [1.6]$$

Here  $V_{PV}$  and  $I_{PV}$  are the PV array voltage and current, respectively.

As soon as the optimal operating point of the P-V plane reaches the right side of the MPP,  $(dI_{PV}/dV_{PV}) + (I_{PV}/V_{PV})$  becomes less than zero. Similarly, when the optimal operating voltage reaches the left of MPP,  $(dI_{PV}/dV_{PV}) + (I_{PV}/V_{PV})$  becomes greater than zero. Hence, the sign of the quantity  $(dI_{PV}/dV_{PV}) + (I_{PV}/V_{PV})$  shows the proper direction of perturb that leads to the



### 2.3.4 Perturb and Observe Method:

In this method, voltage from the array is adjusted by the controller by a small amount and the power is measured. When power increases, further adjustments are carried out until the power is balanced. This method is mostly used due to the ease of it.

Initially the voltage of a cell is increased and the output power is monitored. If power starts to increase the voltage is also increased until the output power starts to decrease again. This process continues until the optimal power point is reached i.e. the MPP.

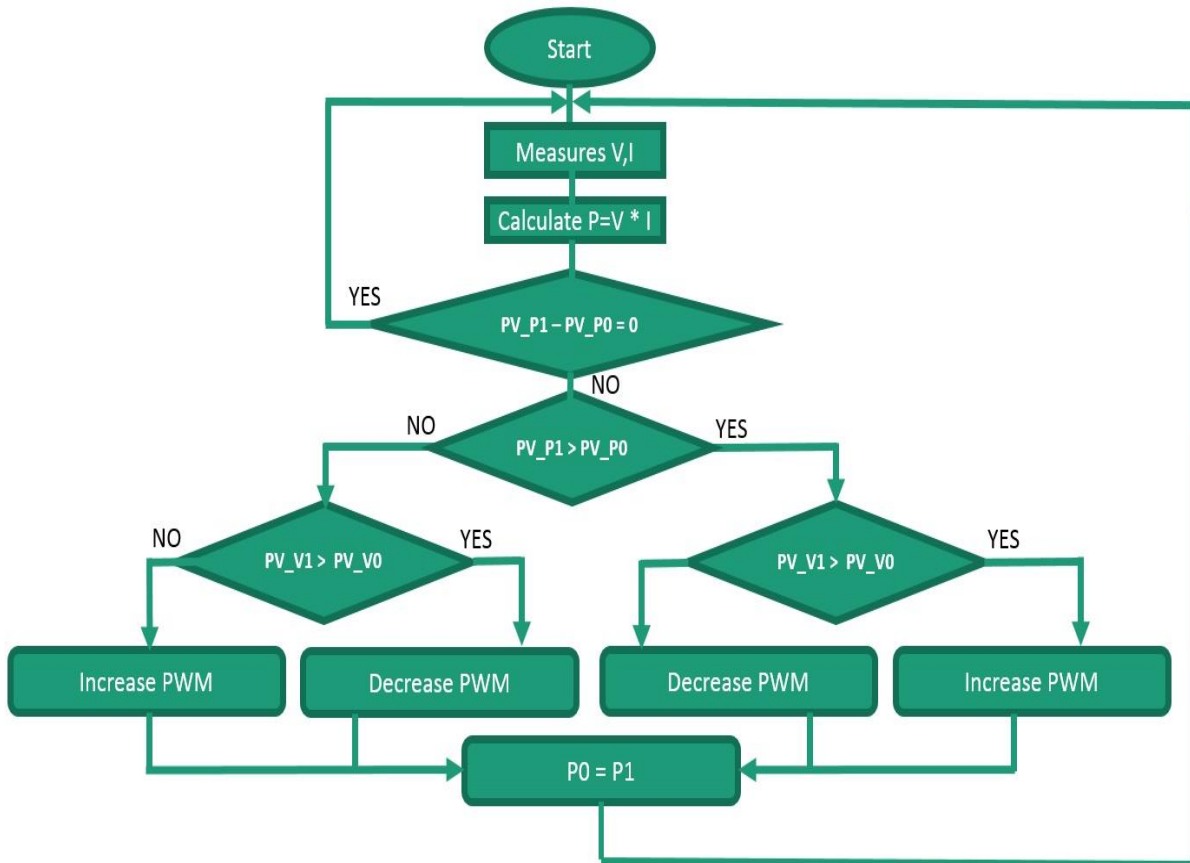

Fig 2.2: Flowchart of perturb & observe

## 2.4 MPPT vs PWM

Though in present world there is one other charge controller **pulse width modulation (PWM)**, the MPPT is preferred more. The main reason would be, a PWM charge controller will just pull down the voltage from the panel to that of the battery and that too under tropical conditions, whereas, an MPPT is designed to obtain maximum efficiency under all conditions and it can vary the voltage requirement of load and battery all at once.

The performance efficiency of an MPPT is considerable (10-40%) when the solar temperature is either very high (above 75°C) or very low (below 45°C) or when irradiance is much low. At low irradiance or high temperature the output voltage of the array undergoes a sudden downfall. In such case more cells could be connected in series so that the battery voltage is exceeded by the out voltage of array by a reasonable amount. Also according to Ohm's law, the losses occurring owing to the resistance of the cable are,

$$P_c \text{ (Watt)} = R_c \times I^2 \quad [1.1]$$

This formula shows that while the array voltage is being doubled, the cross sectional area could be increased by a factor of four for a certain cable loss.

For a given supposed power, if more number of cells is used in series the output voltage will be increased and the output current will be decreased. Since  $P = V \times I$ , so for power to remain same if V increases I must decrease. When the size of the array increases, so does the cable length. So, by connecting more cells in series the cross sectional area of the cable can be decreased which leads to a drop in cost. This makes the installation of MPPT more convincing once the array power jumps to few hundred (12V battery) or several hundred Watts (24V or 48V battery).

In conclusion, while PWM charge controllers are a considerable option for low budget minor systems only between a moderate to high solar cell temperature, the MPPT controller is

potentially necessary for high power systems (due to the low cost because of smaller cross sectional area of the cable).

## 2.5 Hybrid System

Off-grid generation of power is important for remote areas where grid connection is a problematic issue i.e. impossible in terms of geography and cost like villages, islands and areas where natural preservation is a concern. Using hybrid power systems to harness renewable energy sources in abundance is the best most cost-effective way to provide electricity to such remote areas.

A hybrid system is a combination of multiple resources such as- solar, wind, biomass, micro/mini-hydropower with various other technologies like generators (diesel) and batteries. Since the hybrid system is an off-grid power generation, it will be cost effective in many cases. Therefore, the preference for renewable energy is getting higher day by day.

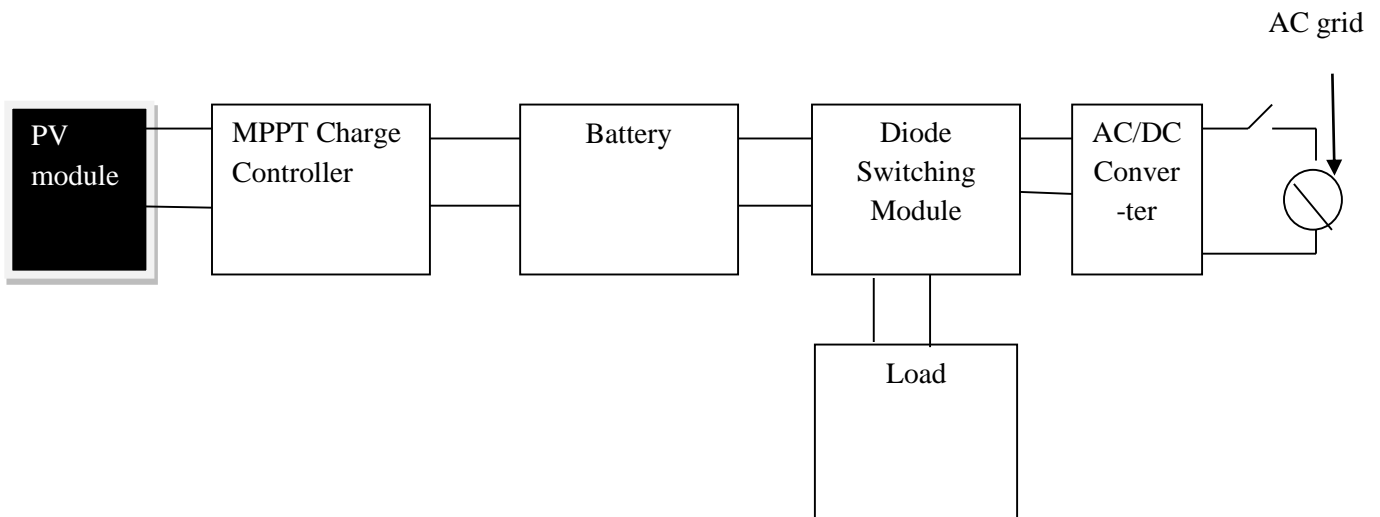

Fig 2.3: Block Diagram of a Hybrid System

### **2.5.1 Advantages of Hybrid System:**

- By varying the power sources a strong power supply and minimization of downtime can be obtained at a time of outage of power. This power outage can be caused by system failure or disruption in diesel supply, under such circumstances an alternative system i.e. hybrid system, can be a reliable power supply. Not only does it consists of fewer moving parts, it also requires less maintenance.
- A hybrid system allows more cost savings with solar panel through improved efficiency and lower equipment and utility cost.
- Stand-alone equipment like batteries and others requires a complete functional off-grid solar system. This contributes to cost as well as maintenance. Hybrid systems are generally cheaper and simpler in comparison.

# Chapter 3

## 3.1 Components

1. PIC18F452
2. Current sensor (ACS712)
3. Buck converter (LM2596)
4. LCD Display (20x4)
5. MOSFETs (3x IRFZ44N)
6. MOSFET Driver (IR2104)
7. Transistor (2x 2N2222)
8. Diodes (2x IN4148, 1x UF4007, 1x MBR20100CT, 2x SBL4040PT)
9. Resistors (3x 100K, 2x 20K, 2x 10K, 1x 470K)
10. Potentiometers (3x 1K)
11. Capacitors (4x 0.1uF, 10uf, 100uF, 220uF)
12. Inductor (40uH)
13. PCB (printed circuit board)
14. Wires
15. Header pins
16. DIP socket (4pin, 20pin)
17. Screw terminals (16x 2pin)
18. Fuses (5)
19. Fuse holder (5)
20. Cable lug (12)
21. Heat sinks
22. Screws/nuts/bolts
23. Soldering iron
24. Drill
25. Wire stripper
26. Wire cutter
27. Screw driver
28. Anti-cutter
29. Pencil & ruler
30. Ferric chloride powder (for PCB etching)
31. Solar panel (100W)

## **3.2 Working Procedure of MPPT Charge Controller**

### **3.2.1 At a glance:**

1. We studied about MPPT charge controller, about the MPP tracking algorithms. We searched for similar projects.
2. After getting the idea, we designed a circuit schematic for MPPT charge controller. We simulated some parts of it and then designed the PCB using EasyPC (PCB designing software).
3. After having done with the designing, we had to do the PCB etching, placing the components and soldering them. Then the PCB looked like this:
4. We wrote a code in mikroC and uploaded it in the microcontroller (PIC18F452) using the ICSP port.
5. We connected a 100W solar panel and a 12V battery and a DC load to the device and tested it. Initially it was not working but after making some changes in the code and circuit, it worked perfectly.
6. We tested the circuit and collected some data. We used MATLAB to plot them in a graph.
7. Then we made a diode switching module. With this, we can supply power simultaneously to load by both grid and battery (the solar power). Making this was definitely not easy. We had to think a lot and then we found the idea of a diode switching module. Again we designed the PCB and finally made it. It looks like this:
8. We connected the diode switching module with the MPPT charge controller and it worked fine.



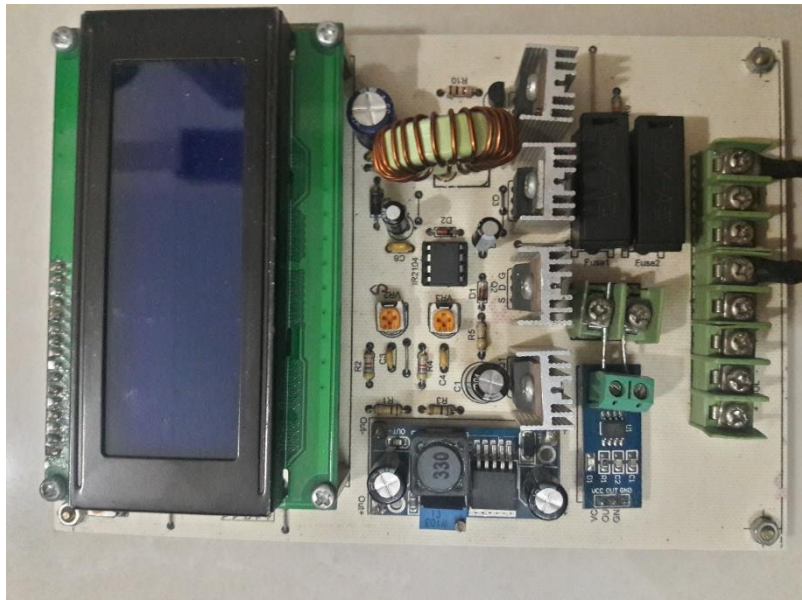

Fig 3.1: MPPT charge controller



Fig3.2: Diode switching module

### **3.2.2 Algorithm:**

We followed the “Perturb and Observe” algorithm (see figure 2.3) to track the maximum power of the PV panel. The basic idea of this algorithm is simple.

1. The microcontroller senses the PV module terminal voltage (V) using a voltage divider circuit and the current (I) that is flowing from the PV panel to the MPPT charge controller (using a current sensor).
2. Then the microcontroller calculates power  $P = V \cdot I$
3. Then it checks if the current P value is greater than the previous P value. If yes, it checks if the current V value is greater than the previous V value. If yes, it increases PWM, else it decreases PWM.
4. And if the current P value is less than the previous P value, it checks if current V value is greater than the previous V value. If yes, it decreases PWM, else it increases PWM.

We uploaded these commands in the microcontroller IC (PIC18F452) using mikroC (programming language).

Using the solar voltage sensor, the microcontroller senses the voltage of the solar panel and sends the data to be displayed in the LCD display. With the current sensor, the microcontroller IC works in the same way, measuring the output of it sends data to LCD display. The capacitor C1 is added to make the ADC value stable. The capacitor C2 prevents rapid change of the voltage. This is necessary due to variance of the irradiance – the sunlight does not always remain the same, it changes depending on whether the day is cloudy, dry, etc.

The MOSFETs Q1 and Q2 acts as gates, they determine when and how long the voltage and current can pass through. These MOSFETs are driven by a MOSFET driver. The driver in turn is powered from the solar panels. These MOSFETs are turned ON/OFF in order to be acting as

gate. This is done by sending a signal using a clock pulse with an internal clock with a duty cycle from the microcontroller. The duty cycle keeps on changing according to the code. Sometimes it increases and sometimes decreases. It is mentioned in the algorithm.

### **3.2.3 Buck Converter:**

A Buck converter is a DC-DC converter where the output signal is always either equal to or lower than the input signal.

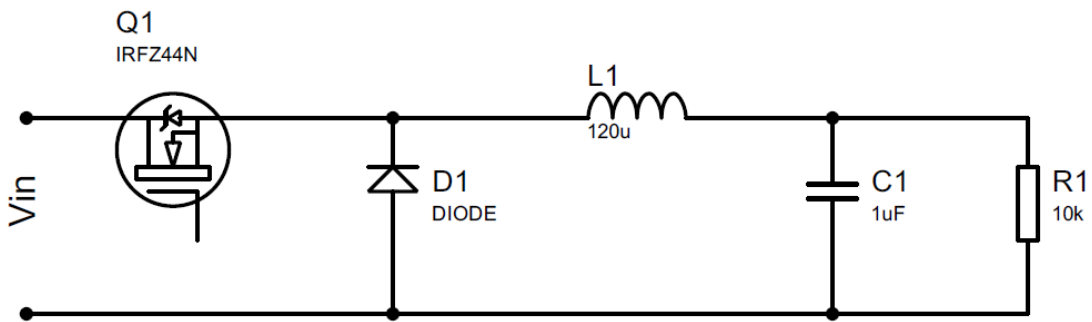

Fig 3.3: Schematic of a buck converter circuit

### **3.2.4 Working Principle of BUCK Converter:**

With MOSFET ON, diode is reverse biased. Current passes through output capacitor, load resistor and inductor. In this case electrical energy is stored in the capacitor and magnetic energy is stored in the inductor.

With MOSFET OFF, energy in the inductor subsided. The diode is forward biased and the current completes the path. As soon as energy is lost from the inductor, energy that was stored in the capacitor is supplied to the load (to maintain the current).

### **3.2.5 Working principle of MOSFET Gate driver:**

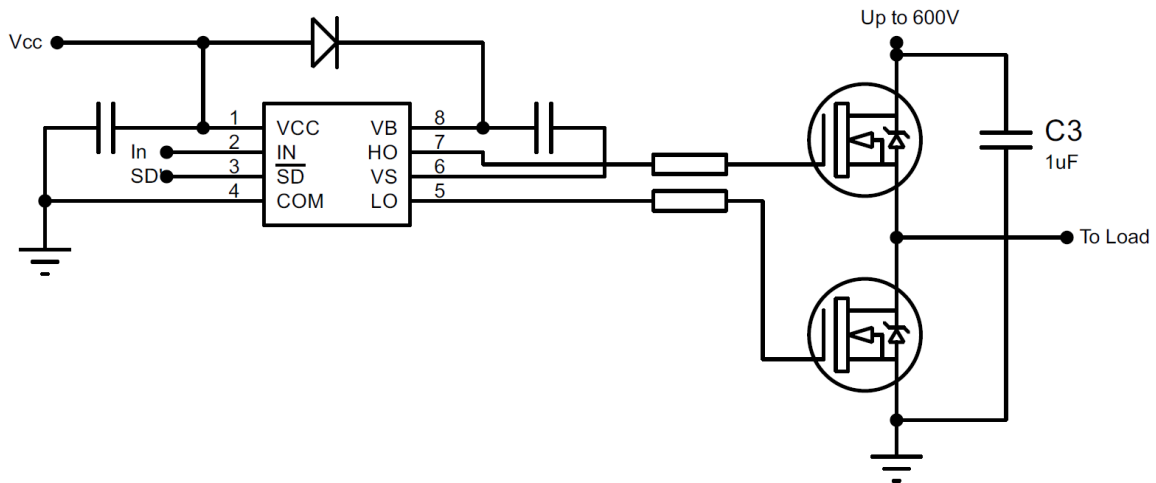

Fig 3.4: MOSFET Gate driver circuit diagram

Microcontroller generates a low current digital output signals and the MOSFET driver uses this signal to drive the gate of a MOSFET. A MOSFET driver can drive a high voltage MOSFET using a 5V digital voltage.

For this design we used IR2104 Half Bridge Driver. This IC takes in a PWM signal from microcontroller and then runs two output MOSFETs using high pin and low pin. However, we used only one MOSFET at the high pin. We have to connect the 2<sup>nd</sup> pin to a digital output of the microcontroller IC and keep that pin high if we want the MOSFET Gate driver to operate.

The inductor in the Buck converter amplifies the current during the time of irradiance variation. This ensures that the power remains constant under every condition.

The amount the voltage in the battery is measured by a second voltage sensor (voltage divider circuit). Again, the microcontroller senses the battery voltage and passes the data to be displayed in the LCD display.

### 3.2.6 Circuit diagram for MPPT Charge Controller:

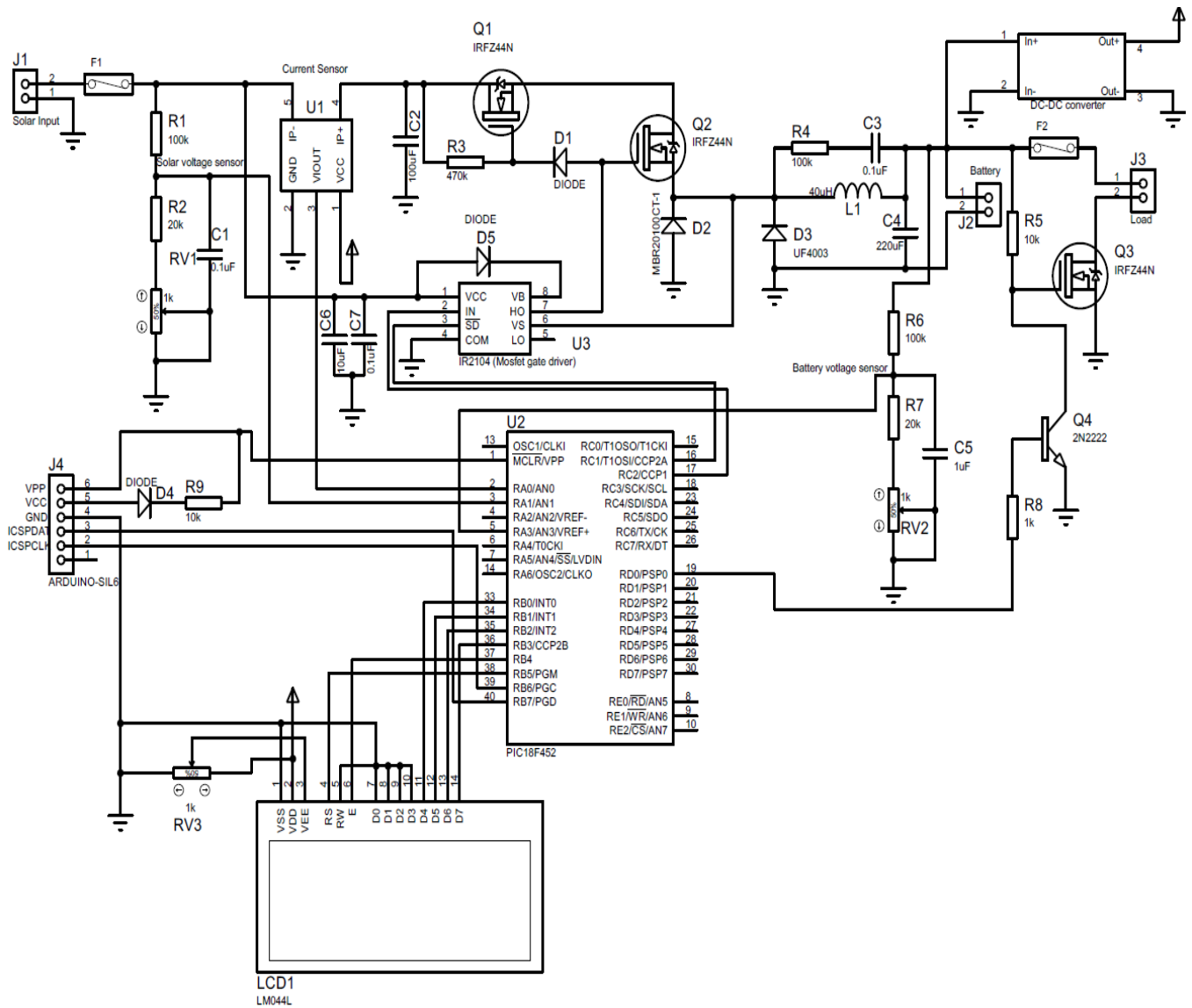

Fig 3.5: MPPT Charge controller circuit diagram

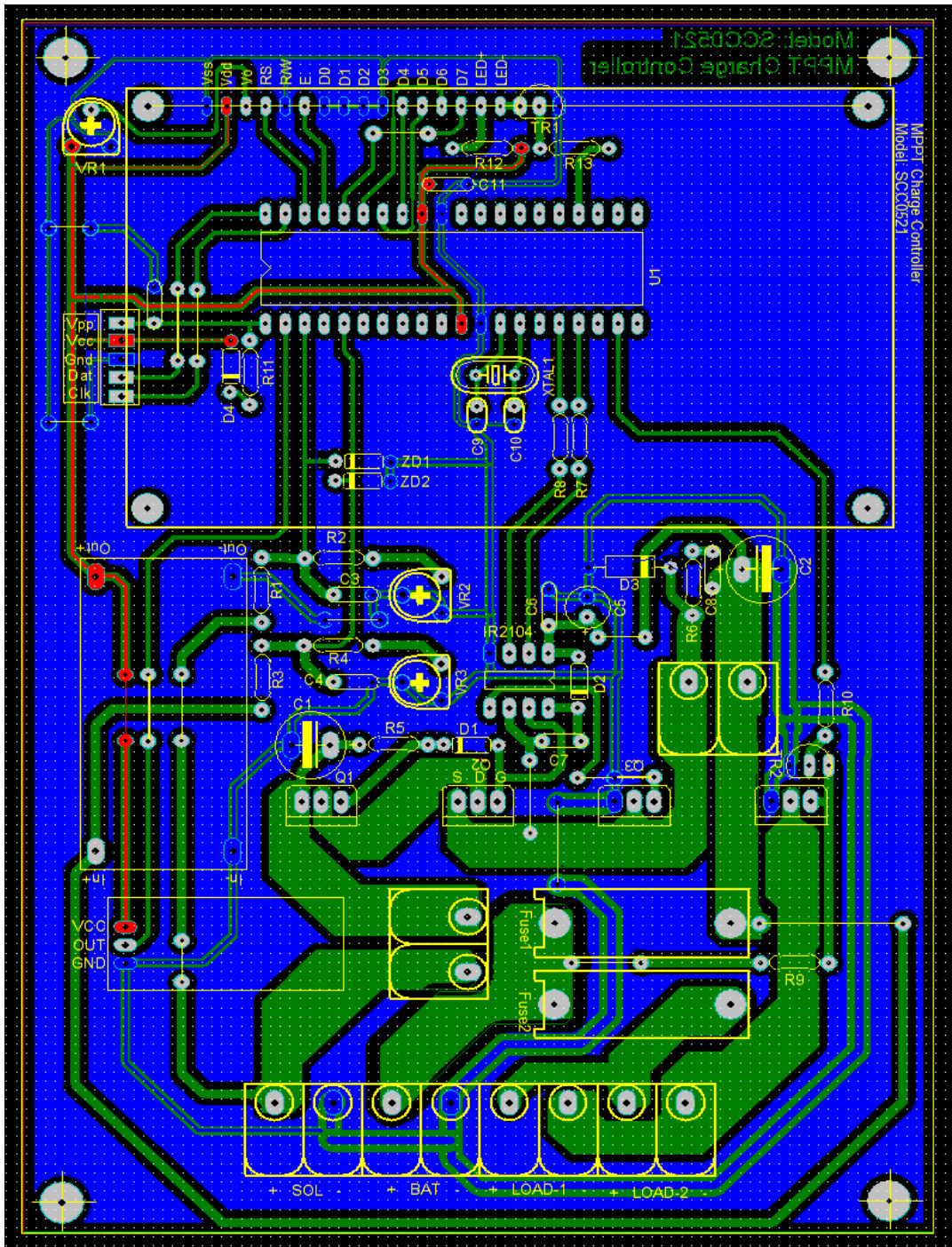

Fig 3.6: PCB layout of the MPPT Charge controller

So, working principle of the complicated two sections (the buck converter circuit and the MOSFET Gate driver circuit) of the MPPT circuit has been described. Now let us see how the circuit works together.

We take the input from the solar panel in the MPPT charge controller and at the output terminal we connect the battery. And with the battery we connect a load in parallel. In the circuit, we have a short circuit protection. We ensured the short circuit protection by using two fuses F1 and F2. It keeps the circuit safe from any type of short circuit situation.

The buck converter contains a MOSFET switch (Q2) and as the energy storage device, we used one inductor (L1) and two capacitors (C1 and C4). The switching current is smoothed by the inductor and the output voltage is smoothed by the capacitor C4. C3 and R4 are used as a snubber network. Snubber network is used here to down on the ringing of the inductor voltage generated by the switching current in the inductor.

If the battery voltage is higher than the solar panel voltage (at night), then current will flow from the battery to the solar panel which is never required. So a MOSFET Q1 is added in the circuit to block the reverse current flowing. This could have been done using a diode. But diodes have a voltage drop which MOSFETs do not have. So, using a MOSFET here is much more efficient.

Q1 and Q2 turns on at the same time and the voltage at its gate drops across R1 so it turns off when Q2 turns off.

IR2014 is an MOSFET gate driver. It helps driving high and low side MOSFETs using a PWM signal generated from the microcontroller IC. Though we did not use the low side MOSFET in our design. Instead of a MOSFET there, we used a diode D2. The third pin (SD') of the gate driver must be supplied a high signal from the microcontroller to make it work.



There are two voltage divider circuits (R1, R2, R7 and R7) in the design. They are used to measure the solar panel voltage and the battery voltage. The output from the dividers are connected to microcontroller's analog pin (pin A1 and pin A3). These pins read the data received from the outputs of the voltage dividers, calibrates them and send them to the LCD display to be displayed. The current sensor ACS712 works in the same method.

To operate the load we added a MOSFET (Q3) and a BJT (Q4). The base of the BJT is connected to a digital pin of the microcontroller (pin D0). The load can be connected and disconnected to/from the battery using this configuration. If a high signal is generated in pin D0, the load will be disconnected and if a low signal is generated, the load will be connected to the battery.

**LVD (LOW Voltage Disconnect):** when the battery voltage is low (10.6V), it cannot supply power to the load. Time must be given to it to get charged at least up to a certain value. So, the battery must be disconnected from load. But the good news is, we do not have to disconnect the battery by ourselves. The microcontroller does it for us. As the microcontroller is reading the battery voltage continuously, when it sees that the battery voltage is low, it generates a high voltage at pin D0 so that the load does not get any supply from the battery. As the battery is disconnected at a low voltage, the method is called "Low Voltage Disconnect". However, we set our low voltage value at 11.5V because it is always good to not go on the border line.

**HVD (High Voltage Disconnect):** When the battery voltage is high (14.6V), it cannot be charged any more as it is fully charged. It needs a load to supply power and discharge itself to get charged again from the solar panel. And again the good news is, we do not have to disconnect the battery by ourselves. The microcontroller does it for us. As the microcontroller is reading the battery voltage continuously, when it senses that the battery voltage is high, it sets the PWM duty cycle to 0% and the inductor does not get the pulsating DC it was getting.

So it stops working and the battery stops getting charged. As the battery is disconnected at a high voltage, the method is called “High Voltage Disconnect”.

### **3.2.7 Working procedure of the Diode Switching Module:**

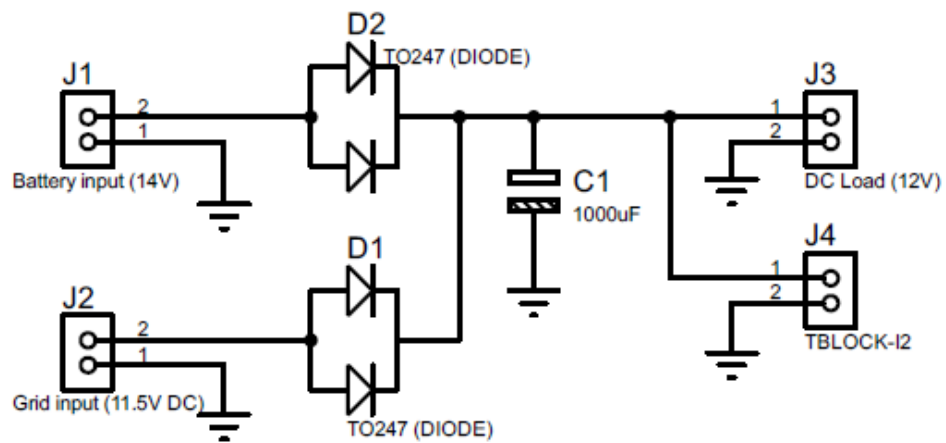

Fig 3.7: Diode Switching Module schematic

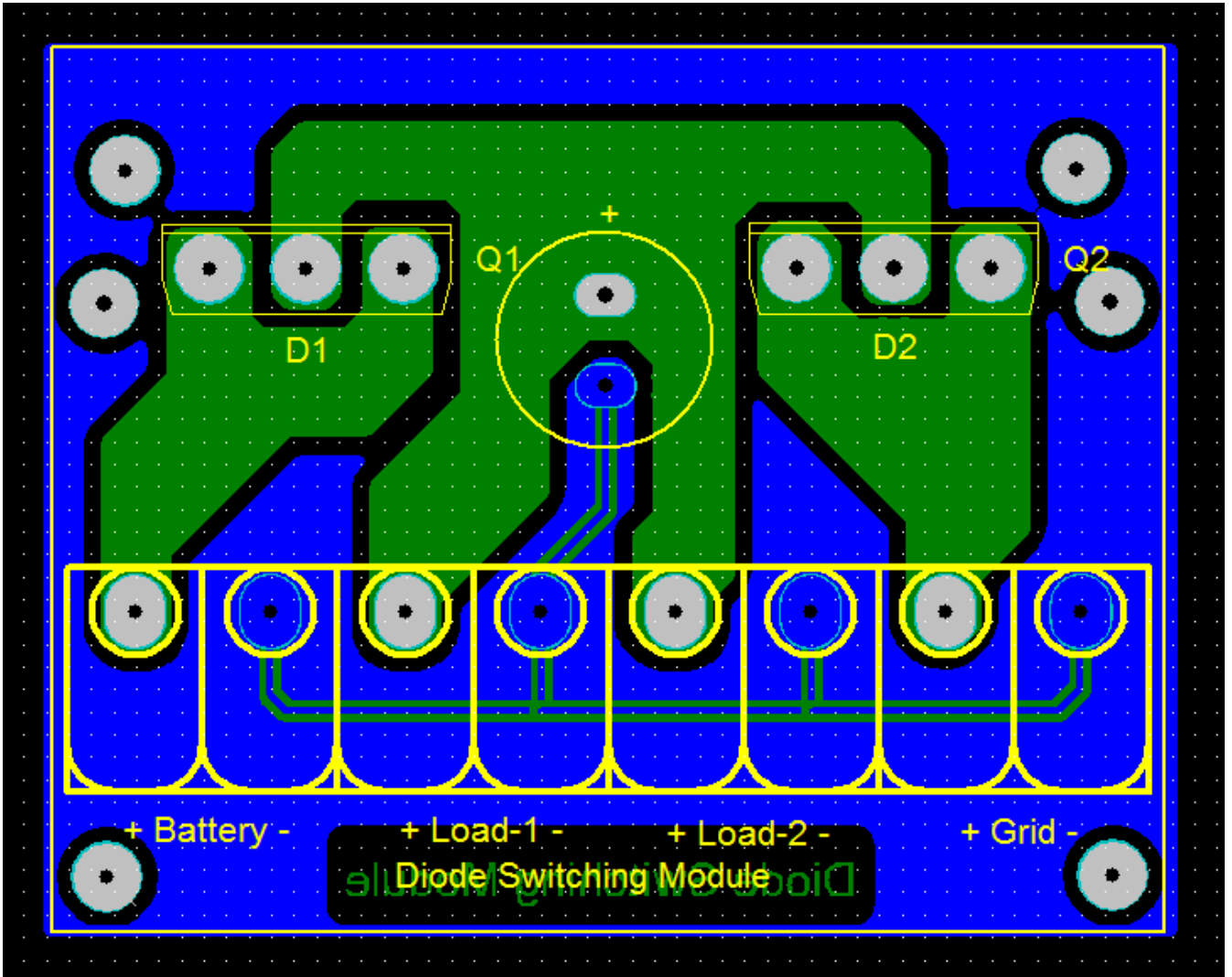

Fig 3.8: Diode Switching Module PCB layout

As we talked earlier we are working with a system where for power we will depend both on grid and solar simultaneously, hence this is achievable using diode switching module. This module consist of two inputs (J1, J2), two outputs (J3, J4), two diodes (D1, D2) and capacitor (C1). The working principle of this is very simple. As seen above there are two inputs, one input will be connected to the output of our MPPT charge controller and the other one will be connected to a 12V AC-DC converter. The reason behind using the converter is that as we are using a DC load, we the need the input current of J2 to be DC. The converter does this by stepping down the voltage of the grid from 220V to 11.5V and at the same time it converts AC to DC. Also there are two outputs where two 12V DC loads will be connected.

The working principle of this module is very simple. At the inputs there will be two voltages, one from solar and another from grid to converter then to the input. Yet two voltages can't exist at the same time at the same node, so what we can deduce is that only one supply can be given at a time. This is the done by the diodes (D1, D2). We will calibrate the voltages at the two inputs in such a way that one of the diodes will be forward biased and the other will be reverse biased. A fixed voltage from the converter will be set at J2. When the battery voltage is more than the converted voltage at J2 then D2 will be forward bias and D1 will be reverse bias. At that time battery is supplying power to the loads. On the other hand when batter voltage is lower than the converted voltage, D1 will be forward bias and D2 will be reverse biased. This time the power supply to the loads are given by the grid and the battery is getting charged again. When the battery voltage will be greater than grid voltage then D2 will again be in forward bias and the whole process will repeat again. This switching will be constantly occurring depending on the voltages. A capacitor is C1 is used so that when the switching occurs the output of the load stays steady. As per our purpose we are using a 12V battery and setting the converter output to 11.5V. The above phenomenon will occur when the battery voltage (12V) will change with respect to the converted output voltage (11.5V).

# Chapter 4

## 4.1 Result

In this section we will discuss what all the tests we conducted and their respective results. We will start with the I-V characteristics of our 100W solar panel, what are the graphs we obtained, at what conditions and will also show the corresponding P-V graph. There is also another section which includes the electrical billing system of our country. Using this method we calculated how much we need to pay if we replace all the bulbs in the building 05 of BRAC University with DC bulbs and also totally depending on the grid as well. Having showed that we also mentioned how much electricity bill we can save if we use our grid connected hybrid solar system also keeping in mind the total installation cost of our system.

## 4.2 I-V & P-V graphs of 100W Solar Panel

By now we know what will be the shape of the graph for an ideal solar panel. The solar panel we used could supply power of 100W with rated voltage of 20V and 5A rated current. We obtained three I-V graphs for three different weather situations.

- The sky was clear, the sun's irradiance level was high and constant and the surrounding temperature was about 33°C.

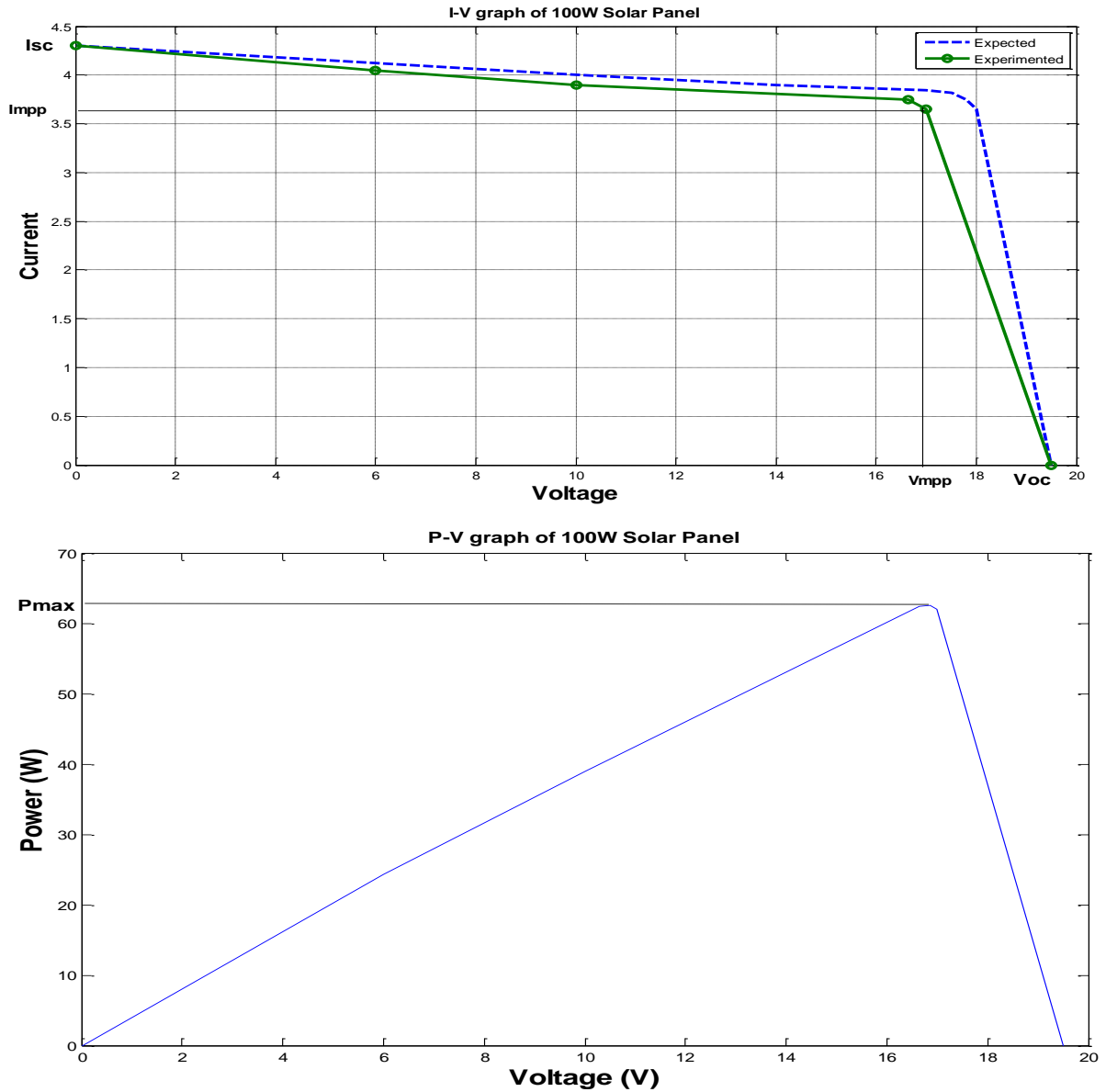

Fig 4.1: I-V curve and P-V curve

- The sky was partly cloudy, the sun's irradiance level was quite high and the temperature was around 30°C.

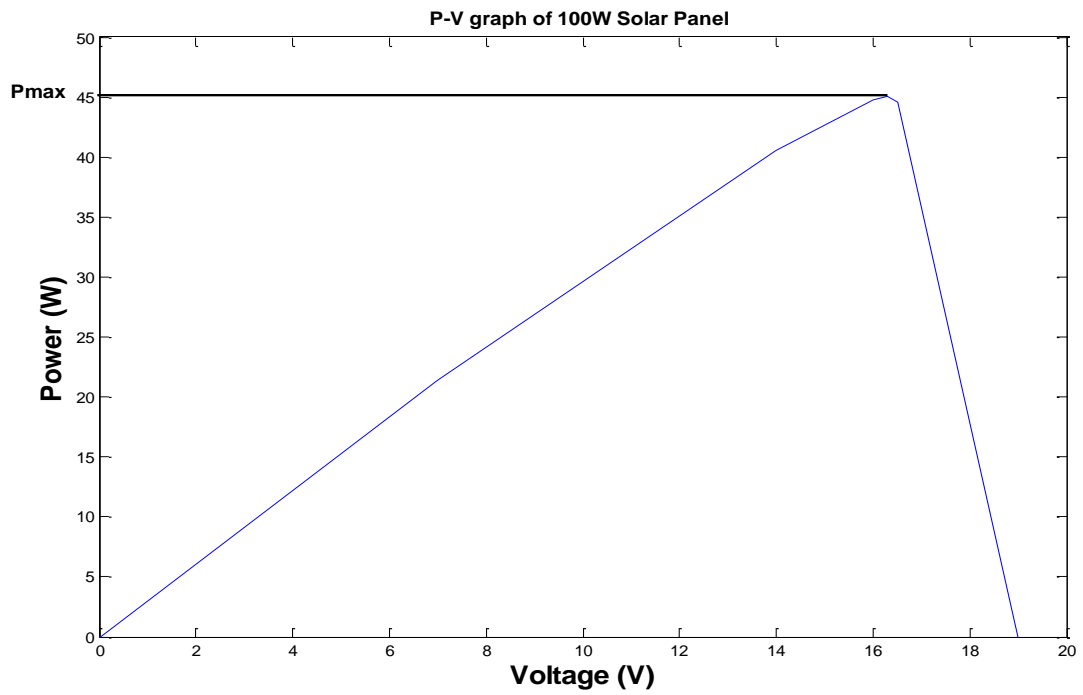
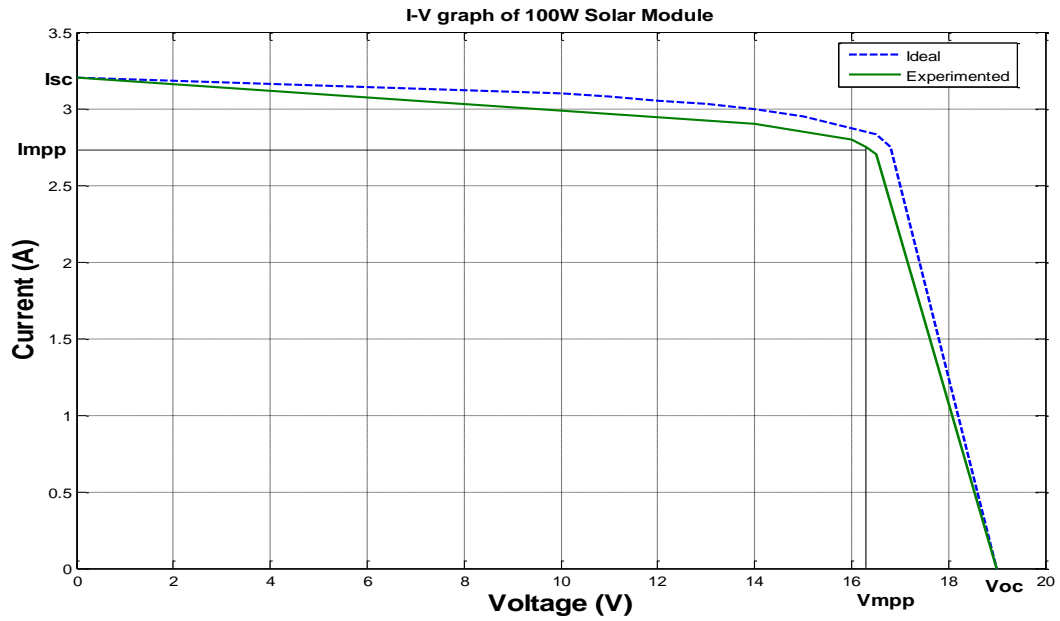

Fig 4.2: I-V curve and P-V curve

- It was raining, the sun's irradiance level was very low and the temperature was around 27°C.

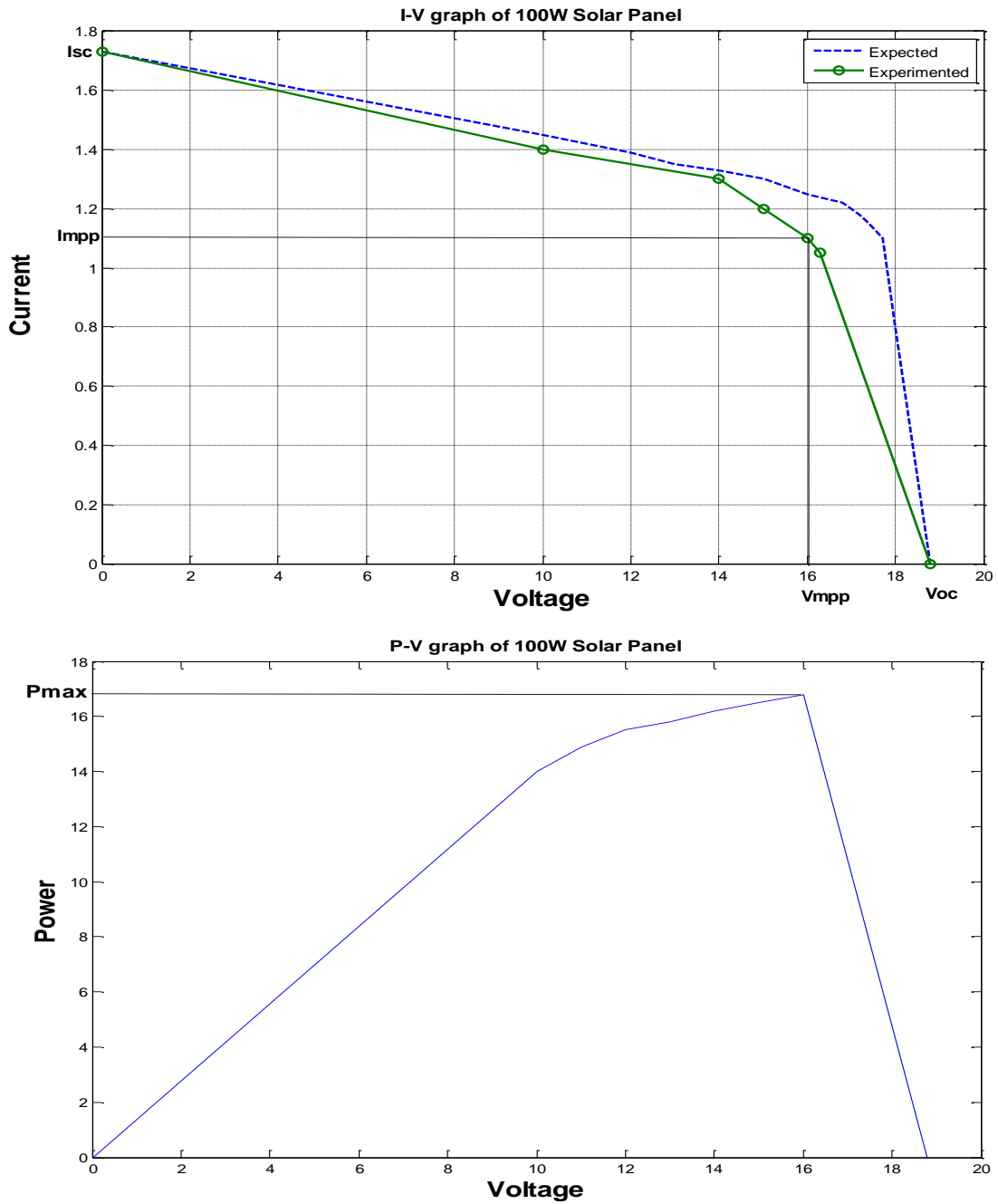

Fig 4.3: I-V curve and P-V curve



### 4.3 Fill Factor

$$FF = (V_{Mpp} \times I_{Mpp}) \div (V_{OC} \times I_{sc})$$

	V <sub>OC</sub> (V)	I <sub>sc</sub> (A)	V <sub>Mpp</sub> (V)	I <sub>Mpp</sub> (A)	FF
Graph-1	19.5	4.3	17	3.65	0.74
Graph-2	19	3.2	16.5	2.7	0.73
Graph-3	18.8	1.73	16	1.05	0.52

Table 4.1: Fill Factor Calculations

### 4.4 Billing and Savings

We are only concerned about the bulbs which we want to replace with DC bulbs in UB 05, hence we calculated the electricity bill for all those bulbs over a year. To calculate the bill we used an online electricity bill calculator [17] which is used for residential purpose in Bangladesh. You just need to enter your KWh rating and a table is displayed there that shows your total bill for that unit.

We know,

Power consumption of each lamp = 30W

Total number of lamps in UB5 (assumption) = 210

Total power consumption =  $30 \times 210 = 6.3KW$

Assuming all 210 lamps work from 9:00-5:00 (office time) = 8 hours

Total unit =  $(30 \times 210 \times 8) \div 1000 = 50.4KWh$

<b>Range</b>	<b>Price/Unit</b>	<b>Unit</b>	<b>Bill (BDT)</b>
1-75	3.8	75	285
76-200	5.14	125	642.5
201-300	5.36	100	536
301-400	8.7	200	1,740
601-1000000	9.98	912	9,101.76
		<b>Bill</b>	<b>12,868.26</b>
		<b>Meter Bill</b>	<b>55</b>
		<b>Total</b>	<b>12,923.26</b>
		<b>VAT</b>	<b>646.163</b>
		<b>G. Total</b>	<b>13,569.423</b>

Table 4.2: Billing of 210 bulbs over a month

Here we can see that the electricity bill over a month for 210 bulbs in UB 05 is 13,569.423 BDT and for over a year our bill is roughly around 1,62,833.075 BDT. However, if we install our system then we save approximately 80% of the total cost. The reason is solar energy cannot be obtained for the whole day which is why we estimated cost saving roughly from 80%.

80% of 13,569.423 BDT = 10,855.53 BDT (monthly savings)

So, yearly saving =  $10,855.53 \times 12 = 1,30,266.46$  BDT

## 4.5 Installation Cost

To generate power supply for 6.3KW, we have to use solar panel of at least 7KW.

Price of 1W panel = 70 BDT

so, price of 7KW = 4, 90,000 BDT

Price of AC-DC converter (12V, 120W) = 1,000 BDT

Although the AC-DC converter are of 120W, we will not provide full load to this. Instead we will give 60% of the rated power.

60% of 120W = 72W

therefore, the number of AC-DC converter required =  $6.3\text{KW}/72\text{W}$

$$= 6,300\text{W}/72\text{W}$$

$$= 87.5 \approx 88$$

Price of each AC-DC converter = 1,000 BDT

so, price of 88 AC-DC converters =  $88 \times 1,000 = 88,000$  BDT

Cost of other utilities (batteries, labor cost, bulbs etc.)  $\approx 3, 00,000$  BDT

Total cost =  $(4, 90,000 + 88,000 + 3, 00,000)$  BDT = 8, 78,000 BDT

Though the installation cost is initially high, however, it will be beneficial at long-term. If we run this system for roughly 8 years this cost will be compensated and then the rest will be profit.

# Chapter 5

## 5.1 Conclusion and future aspects

This thesis project is a very sophisticated design of a solar charge controller and its incorporation with grid system. With a lot of references and our advisors help we were able to design the charge controller with MPPT technique. One indication that our charge controller was working was based on the constant change of the duty cycle which showed in the LCD display. It tells that the charge controller is constantly tracking the maximum power point by increasing and decreasing the duty cycle. Our another design which is diode switching module was also working perfectly because we saw using multi meter that current was flowing to the load from both battery and grid.

For our future research we want to create a more advanced and bigger hybrid system with which we can implement for industrial purpose. We expect after implementing this system in an industry that the cost recovery will be much faster than that of residential use and it will be more cost effective in the long run.

## References:

- [1] <http://www.solar-energy-at-home.com/why-is-solar-energy-important.html>
- [2]Md. Alam Hossain Mondal, *Economic viability of solar home systems: Case study of Bangladesh*, Volume 35, Issue 6, June 2010.  
<http://www.sciencedirect.com/science/article/pii/S096014810900531X>
- [3]A K Hossain O Badr, *Prospects of renewable energy utilisation for electricity generation in Bangladesh*, Volume 11, Issue 8, October 2007.  
<http://www.sciencedirect.com/science/article/pii/S1364032106000256>
- [4]Alireza Khaligh & Omer C. Onar, *Energy harvesting- Solar, Wind, Oceans and Energy Conversions System*, 2010.
- [5]<http://dspace.bracu.ac.bd/xmlui/bitstream/handle/10361/2120/DESIGNING%20SMART%20CHARGE%20CONTROLLER.pdf?sequence=1&isAllowed=y>
- [6]Shusmita Rahman, Nadia Sultana Oni, Quazi Abdullah Ibn Masud , *Design of a Charge Controller Circuit with MPPT Power Point Tracker (MPPT) for Photovoltaic System*, December 15, 2012.  
<http://dspace.bracu.ac.bd/xmlui/bitstream/handle/10361/2389/Design%20of%20a%20Charge%20Controller%20Circuit.pdf.pdf?sequence=1&isAllowed=y>
- [7]<http://dspace.bracu.ac.bd/xmlui/bitstream/handle/10361/2120/DESIGNING%20SMART%20CHARGE%20CONTROLLER.pdf?sequence=1&isAllowed=y>
- [8]<https://www.solar-electric.com/mppt-solar-charge-controllers.html/>
- [9]<https://www.victronenergy.com/blog/2014/07/21/which-solar-charge-controller-pwm-or-mppt/>

[10] <http://www.schams-solar.de/download/DESCRIPTION/comparison-mppt-pwm.pdf>

[11] <http://www.wseas.us/e-library/transactions/power/2008/27-545.pdf>

[12] [http://www.ijeit.com/vol%202/Issue%206/IJEIT1412201212\\_01.pdf](http://www.ijeit.com/vol%202/Issue%206/IJEIT1412201212_01.pdf)

[13] <http://wseas.us/e-library/conferences/2008/norway/ace/16-ace.pdf>

[14] [http://www.isesco.org.ma/ISESCO\\_Technology\\_Vision/NUM01/doc/Kamaruzzaman%20Sopian.pdf](http://www.isesco.org.ma/ISESCO_Technology_Vision/NUM01/doc/Kamaruzzaman%20Sopian.pdf)

[15] <http://energyinformative.org/grid-tied-off-grid-and-hybrid-solar-systems/>

[16] [https://www.iea.org/media/openbulletin/Rural\\_Electrification\\_with\\_PV\\_Hybrid\\_systems.pdf](https://www.iea.org/media/openbulletin/Rural_Electrification_with_PV_Hybrid_systems.pdf)

[17] <http://electricbillbd.com/>