



Inspiring Excellence

Analysis of Thyristor Based Dual Converter Controlling the Firing Angle for HVDC Transmission

A thesis submitted to the Department of Electrical and Electronic Engineering

Prepared By

Mohammed Fuad Hassan	13321002
K. M. Mahmudul Monir	13321059
Md. Ismail Hossain	14321045
Sudipto Das Joy	13321077

Supervised by

Dr. Amina Hasan Abedin
Assistant Professor

Department of Electrical and Electronic Engineering
BRAC University, Dhaka
Bangladesh

Declaration

We hereby declare that this thesis paper titled ‘Modeling an HVDC 12 pulse converter’ is done only by our research along with the research’s implementation results found by us. Every material of research or thesis used from other sources has been mentioned along with their references. This thesis report is being submitted to the Department of Electrical and Electronic Engineering of BRAC University.

Signature of Supervisor

Signature of Authors

Sudipto Das Joy

Mohammed Fuad Hassan

K. M. Mahmudul Monir

Md. Ismail Hossain

Date of Submission: December 24, 2017

Acknowledgement

We would like to seize the opportunity to express a big appreciation to those who helped us for this project. Special gratitude to our supervisor, Dr. Amina Hasan Abedin, Assistant Professor, Department of Electrical and Electronic Engineering, BRAC University, Bangladesh, who made it possible by supervising us throughout frequent consultations meeting and feedback sessions .

We would like to extend our appreciation to our class mates and the respective Lab assistants for their moral support and valuable comment during our work, which gave us inspiration to improve our thesis.

Finally, we are very Thankful to all the teachers and our parents for their inspiration and continues support and also BRAC University for giving us the opportunity to complete our research.

Thank you.

Abstract

Electricity is one of the most reliable energy sources because it can be converted into any form of energy and can easily be transmitted from one place to another. For transmission purpose we use Alternating current because producing the AC current is much more efficient than DC. The problem occurs when we want to transmit the electric energy to long distance AC current causes more transmission loss than DC current. That is why, for a long transmission line we use HVDC Transmission where AC voltage is converted in DC and after transmitting to other end DC is again converted into AC for distribution purpose. Another reason for HVDC concept is that renewable energy sources such as solar grid are placed at remote places and they produce a DC current. To transmit them to the end user we have to convert them into AC current. In our research we have simulated a three phase dual converter. In a dual converter, a single circuit can be used as a rectifier and inverter by changing the firing angle of conducting device. We have used a three phase source along with controlled full bridge rectifier consisting SCR. SCRs can be switched on or off using a gate pulse and controlling the time delay of SCR we can control the output. After simulating the circuit and observing the output we found that it is possible to use a controlled three phase rectifier as an inverter by changing the firing angle of SCR

Table of Contents

CHAPTER 01	1
Introduction.....	1
1.1 Motivation.....	1
1.2 Advantages and disadvantages.....	4
1.3 Configurations of HVDC transmission systems	7
1.3.1 Monopolar link	7
1.3.2 Bipolar link.....	8
1.3.3 Homopolar link.....	9
SCR Controlled Rectifier	11
2.1 Introduction.....	11
2.2 Operation of SCR.....	12
2.3 Three Phase Fully Controlled Rectifier.....	16
2.4 SYNCHRONIZING SIGNALS	20
2.4 MATHEMATICAL ANALYSIS.....	21
2.5 AVERAGE OUTPUT VOLTAGE.....	21
2.6 RMS OUTPUT VOLTAGE.....	22
2.7 RMS LINE CURRENT.....	23
CHAPTER 3	24
Simulation of SCR Controlled Rectifier	25
3.1 Ideal Circuit Setup using SCR (Schematics).....	25
3.2 Practical 6 pulse circuit setup using Switches (Schematics).....	27
3.3 Simulation Graphs – 6 pulse	29
3.4 Practical 12 pulse circuit setup using Switches (Schematics).....	41
3.5 Simulation Graphs – 12 pulse	43
Chapter 4	52
4.1 Conclusion:.....	52
Reference.....	53

List of Figures

Fig: 1.3.1 Monopolar Link [7].....	8
Fig: 1.3.2 Bipolar Link[7].....	9
Fig:1.3.3 Homopolar Link [7]	10
Fig: 2.2.1 Silicon Controlled Rectifier(SCR) [8].....	13
Fig: 2.2.2 BJT equivalent circuit [9].....	14
Fig: 2.2.3 V-I Characteristics of SCR [10].....	15
Fig 2.3 Three Phase Fully Controlled Rectifier [5].....	17
Fig:3.1 6 pulse rectifier using SCR.....	255
Fig:3.2 6 pulse rectifier using Switches	277
Fig 3.2.1: Output wave shape, $\alpha = 0^\circ$	29
Fig:3.2.2 Fig:3.2.1 Output wave shape, $\alpha = 15^\circ$	300
Fig:3.2.3 Output wave shape, $\alpha = 30^\circ$	311
Fig:3.2.4 Output wave shape, $\alpha = 45^\circ$	322
Fig:3.2.5 Output wave shape, $\alpha = 60^\circ$	333
Fig:3.2.6 Output wave shape, $\alpha = 75^\circ$	344
Fig:3.2.7 Output wave shape, $\alpha = 90^\circ$	355
Fig:3.2.8 Output wave shape, $\alpha = 105^\circ$	365
Fig:3.2.9 Output wave shape, $\alpha = 120^\circ$	366
Fig:3.2.10 Output wave shape, $\alpha = 135^\circ$	377
Fig:3.2.11 Output wave shape, $\alpha = 150^\circ$	388
Fig:3.2.12 Output wave shape, $\alpha = 165^\circ$	39
Fig:3.2.13 Output wave shape, $\alpha = 180^\circ$	400
Fig:3.3 12 pulse rectifier using Switches	411
Fig3.3.1:Input wave shape	433
Fig:3.3.2 Output wave shape, $\alpha = 0^\circ$	444
Fig:3.3.3 Output wave shape, $\alpha = 15^\circ$	444
Fig:3.3.4 Output wave shape, $\alpha = 30^\circ$	455
Fig:3.3.5 Output wave shape, $\alpha = 45^\circ$	466
Fig:3.3.6 Output wave shape, $\alpha = 60^\circ$	466

Fig:3.3.7 Output wave shape, $\alpha = 75^\circ$	477
Fig:3.3.8 Output wave shape, $\alpha = 90^\circ$	477
Fig:3.3.9 Output wave shape, $\alpha = 105^\circ$	48
Fig:3.3.10 Output wave shape, $\alpha = 120^\circ$	48
Fig:3.3.11 Output wave shape, $\alpha = 135^\circ$	49
Fig:3.3.12 Output wave shape, $\alpha = 150^\circ$	49
Fig:3.3.13 Output wave shape, $\alpha = 165^\circ$	500
Fig:3.3.14 Output wave shape, $\alpha = 180^\circ$	511

List of Tables

Table: 2.3.1 Diodes and firing angles [5].....	18
Table: 2.3.2 Switches and angles [5].....	19

CHAPTER 01

Introduction

1.1 Motivation

HVDC is the oldest and "newest" method of distant transmission; today it has reemerged in an advanced form to possibly replace major AC high-voltage routes. It is the 'oldest' because the primitive electric power transmissions were all done in DC. The principal long-separate transmission of electric power was shown utilizing direct current in 1882 at Miesbach-Munich Power Transmission, however just 1.5 kW was transmitted. An early strategy for high-voltage DC transmission was produced by the Swiss architect René Thury and his technique was incorporated by 1889 in Italy by the Acquedotto De Ferrari-Galliera organization [1]. This framework utilized arrangement associated engine generator sets to build the voltage. Each set was protected from electrical ground and driven by protected shafts from a prime mover. The transmission line was worked in a 'steady present' mode, with up to 5,000 volts over each machine; a few machines having two fold commutators to diminish the voltage on every commutator. This framework transmitted 630 kW at 14 kV DC over a separation of 120 km. The Moutiers– Lyon framework transmitted 8,600 kW of hydroelectric power a separation of 200 km, including 10 km of underground link. This framework utilized eight arrangement associated generators with double commutators for an aggregate voltage of 150,000 volts between the positive and negative shafts, and worked from c.1906 until 1936. Fifteen Thury frameworks were in operation by 1913. Other Thury frameworks working at up to 100 kV DC worked into the 1930s; however the turning hardware required high support and had high vitality misfortune. One way for changing of direct current from a high transmission voltage to bring down usage voltage was to charge arrangement associated batteries, at that point, reconnect the batteries in parallel to serve circulation loads. While no

less than two business establishments were attempted around the turn of the twentieth century, the system was not for the most part helpful inferable from the restricted limit of batteries, challenges in exchanging amongst arrangement and parallel associations, and the innate vitality wastefulness of a battery charge/release cycle.

In the late 1800s, DC couldn't be effectively changed over to high voltages. Thus, Edison proposed an arrangement of little, nearby power plants that would control singular neighborhoods or city areas. Power was dispersed utilizing three wires from the power plant: +110 volts, 0 volts, and - 110 volts. Lights and engines could be associated between either the +110V or 110V attachment and 0V (unbiased). 110V took into account some voltage drop between the plant and the heap (home, office, and so on.).

Despite the fact that the voltage drop over the electrical cables was represented, control plants should have been situated inside 1 mile of the end client. This restriction made power appropriation in country ranges to a great degree troublesome, if certainly feasible.

With Tesla's licenses, Westinghouse attempted to idealize the AC dispersion framework. Transformers gave a modest technique to advance up the voltage of AC to a few thousand volts and withdraw to usable levels. At higher voltages, a similar power could be transmitted at much lower current, which implied less power lost because of protection in the wires. Therefore, substantial power plants could be found numerous miles away and benefit a more prominent number of individuals and structures.

Now, AC power provided the solution to distant transmission. AC also provided a solution to interconnect generation sites. The development of the 3-phase AC power system in the late 1880s proved the effectiveness of the system and electrification of entire cities and regions began in the 1890s. . This was largely because AC could be easily transformed to higher voltages, and therefore could transport power over longer distances than DC.

The question is often asked, "Why use DC transmission?" One response is that losses are lower, but this is not correct. The level of losses is designed into a transmission system and is regulated by the size of conductor selected DC and AC conductors,

either as overhead transmission lines or submarine cables can have lower losses but at higher expense since the larger cross-sectional area will generally result in lower losses but cost more [2]. With the advent of technology and time, we are inclined to get more profit or more comfort without losing more money. The growing need for electricity has now made the AC systems a little bit costly. There is plethora of reasons why HVDC has reemerged as an alternative of AC in spite of being all our industrial and home appliances being used in AC systems. The main drawback now-a-days in AC is in its transmission cost. An overhead DC transmission line with its towers can be intended to be less expensive per unit of length than an identical AC line which is intended to transmit a similar level of electric power. Though the DC converter stations at each end are costlier than the ending stations of an AC line, the aggregate cost of DC transmission is not as much as its AC transmission. The DC transmission line can have a lower visual profile than an equal AC line thus adds to a lower ecological effect. There are other natural preferences to a DC transmission line through electric and attractive fields being DC rather than AC [2].

For submarine or underground link transmission, the breakeven separate is not as much as overhead transmission. It is not down to earth to consider AC link frameworks surpassing 50km. However, DC link transmission frameworks are in benefit whose length is in hundreds of kilometers and even more than 600kilometers. Some AC electric power frameworks are not synchronized to neighboring systems even despite the fact that their physical separations between them are very little. This happens in Japan where a large portion of the nation is a 60 Hz consumer and the other is connected to a 50 Hz system. It is physically difficult to interface the two together by coordinating AC techniques keeping in mind the end goal to trade electric power between them. Be that as it may, if a DC converter station is found in every framework with an interconnecting DC interface between them, it is conceivable to exchange the required power stream despite the fact that the AC frameworks are so associated, remain offbeat.

1.2 Advantages and disadvantages

High voltage DC transmission system is one of the most leading working areas of engineers in today's world. High Voltage Direct Current (HVDC) offers a range of technical, environmental and economic advantages. Over long distances HVDC is a more attractive technology as it is more efficient and has lower electrical losses compared to AC. HVDC is the only viable technology for long distance submarine cable routes due to technical limitations of AC cable technology. The inherent controllability of a HVDC line, due to fast and accurate power electronic control, is a major advantage of HVDC. With the ability to provide constant power as well as a range of other control functions, HVDC has become a very important technology in improving the stability, reliability and transmission capacity of power systems. Demands for long distance transmission is increasing, as sources of renewable energy are generally located far from populous areas where electricity demand is high. All over the world, HVDC is enabling the connection of more renewable energy sources to the grid, replacing conventional power plants and leading to reductions in carbon emissions.

Many researchers around the world talked about the significant advantages of the HVDC systems. First of all, the huge favorable position of HVDC frameworks is that it could be utilized as an attach line to interconnect isolate AC systems. At the point when two independently asynchronous AC frameworks, for case where one works at a recurrence of 50Hz and the other at 60Hz or where the two frameworks are worked at a similar recurrence however unique stage points, utilizing DC current to interface the two AC frameworks is the main useful technique. DC control is autonomous of the recurrence and relative period of the power frameworks. The HVDC interconnection between two AC frameworks won't experience the ill effects of energy swings and danger of tripping from over-burden. HVDC interconnection's execution is greatly improved than AC interconnection. HVDC asynchronous interconnection additionally has great protection impact against blackouts. An HVDC

interconnection between control systems improves control frameworks in limit, controllability and enhances control conveyance rate. With HVDC interconnections, transmitting extra power through the AC frameworks can be accomplished, which creates an intend to enhance frameworks limit. In light of a consistent power exchange, it is anything but difficult to control dynamic power in HVDC interface [3].

Secondly, for a similar transmission limit, HVDC transmission lines cost not as much as HVAC transmission lines in the same length. A bipolar framework just has two lines contrasted with three lines in an AC framework which brings about a littler cost in tower plan and develop for conveying a similar limit control. The Three Gorges Venture in China required 5 x 500kV AC lines compared to the 2 x ± 500 kV, 3000MW bipolar HVDC lines utilized. Control and maintenance devices costs were also reduced.

Thirdly, HVDC has a decent execution in long distance bulk power delivery with underground and submarine links. It can move more power in fewer lines than in AC framework under a similar circumstance. In an AC framework the receptive power stream which caused by the link protection restrains the transmission separation and includes costs. Moreover, reactive power compensation is required in AC transmission framework for long distant control conveyance. Lower line losses and economic advantages improve HVDC for long distance control conveyance. Utilizing underground and submarine links, there is no distant impediment for control conveyance and about a large portion of the line losses of tantamount AC framework. HVDC transmission framework is considered to be an intelligent decision for interfacing seaward breeze homesteads to network or conveying power from remote assets to huge urban regions.

Fourthly, to connect distinctive AC frameworks by HVDC interfaces adequately implies there is no compelling reason to set new power stations furthermore close to the consumer areas. There is no induction or alternating electro-attractive fields shape HVDC transmission. No skin effects, faithful link transmission and lower losses guarantee that there are less ecological effects.

Nothing is perfect. As a result, HVDC has some drawbacks also. Converter stations expected to associate with AC control frameworks are exceptionally costly [4]. Converter substations are more complicated than HVAC substations, in extra converting unit, as well as in more entangled control and controlling frameworks. Rather than AC systems, planning and working multi-terminal HVDC frameworks is intricate. Controlling power flow in such frameworks requires nonstop communication between all terminals, as power flow must be effectively managed by the control framework rather than by the intrinsic properties of the transmission line. While short-circuits occur in the AC control frameworks near associated HVDC substations, power faults likewise happen in the HVDC transmission framework. Inverter substations are generally affected. During short-circuits on the inverter output side, a full HVDC transmission framework power fault can be caused. Power faults because of short-circuits on the rectifier input side are normally proportional to the voltage decrease. Apart from these HVDC has capacity, grounding, radio noise, electro-corrosion, harmonic, stability problems. The interactions between these multiple HVDC schemes will become more important. Communication failures between these HVDC schemes may result in system instability [3].

Most of the aforementioned disadvantages can be got over with the utilization of new innovations. Specifically, inconveniences, for example, an entire power fault of the HVDC transmission framework during short-circuits in the AC control framework and reactive power consumption can be dispensed totally, or generally, with the utilization of turn-off thyristors. Many researchers are focusing on improving high-capacity turn-off thyristors and also on new types of converter devices for high-capacity HVDC transmission.

1.3 Configurations of HVDC transmission systems

We know that HVDC can be connected with two or more networks that have different frequencies and voltages. In order to connect two networks or systems, various types of HVDC links are used. HVDC links are classified into three types. They are:

- Monopolar link
- Bipolar link
- Homopolar link

1.3.1 Monopolar link

In Fig 1.1 it has a single conductor of negative polarity and it uses earth or sea for the return path of the current. Sometimes the metallic return is also used. In the Monopolar link, two converters are placed at the end of each pole. Earthing of poles is done by earth electrodes placed about 15 to 55 km away from the respective terminal stations. But this link has several disadvantages because it uses earth as a return path. The earthed terminal may be connected to the corresponding connection at the inverting station by means of a second conductor [7]. The monopolar link is not much in use nowadays.

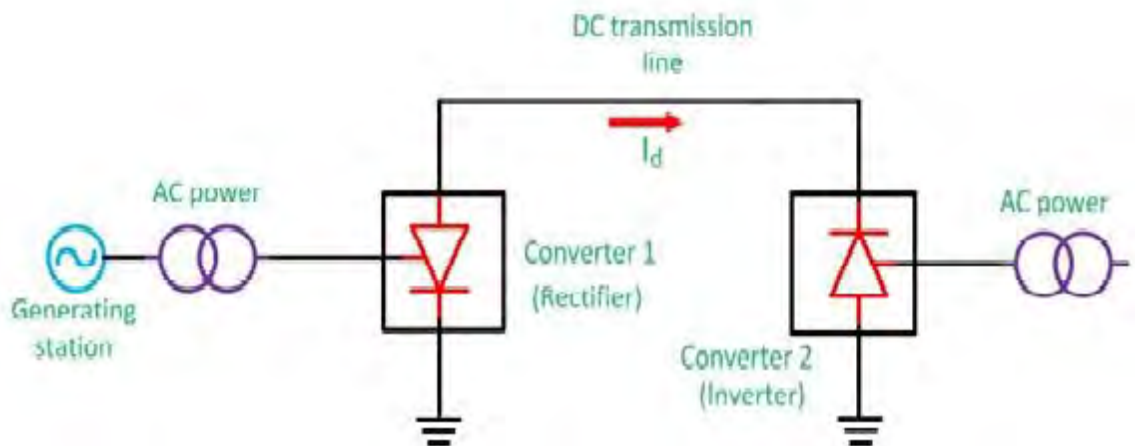

Fig: 1.3.1 Monopolar Link [7]

1.3.2 Bipolar link

The Bipolar link has two conductors one is positive, and the other one is negative to the earth. The link has converter station at each end. The midpoints of the converter stations are earthed through electrodes. The voltage of the earthed electrodes is just half the voltage of the conductor used for transmission of the HVDC. The most significant advantage of the bipolar link is that if any of their links stop operating, the link is converted into Monopolar mode because of the ground return system. The half of the system continues to supply the power. Such types of links are commonly used in the HVDC systems.

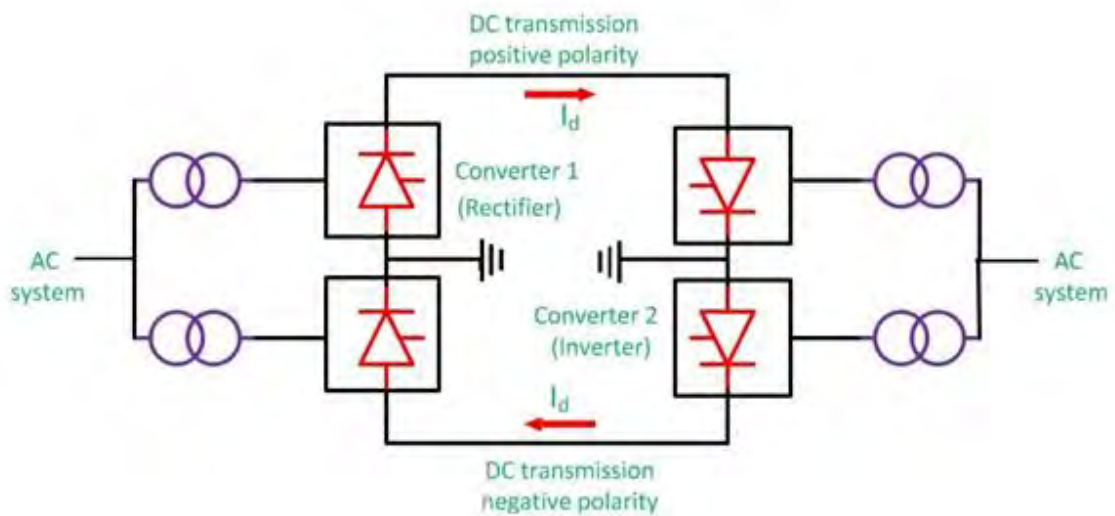

Fig: 1.3.2 Bipolar Link [7]

Currents in two poles are equal so there is no ground current. Since these conductors must be insulated for the full voltage, transmission line cost is higher than a monopole with a return conductor [7].

1.3.3 Homopolar link

Homopolar link uses two conductors of the same polarity usually negative polarity, and always operates with earth or metallic return. In the homopolar link, poles are operated in parallel, which reduces the insulation cost. The homopolar system is not in use today.

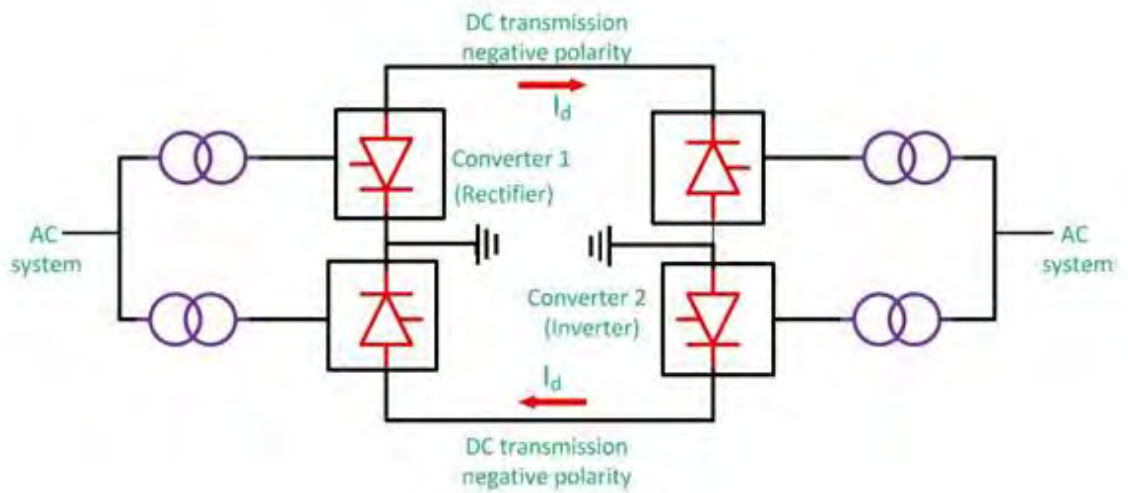

Fig: 1.3.3 Homopolar Link [7]

HVDC is going to rein the power transmission world after Tesla's AC Current. The ample advantages of DC transmission and conversion have paved of the way of uninterrupted, efficient and reliable power transmission.

Chapter 2

SCR Controlled Rectifier

2.1 Introduction

For High Voltage DC operation the use of power electronics is increasing day by day. In most cases the Silicon Controlled Rectifier (SCR) is used. In our thesis, we are also using SCRs in three phase controlled rectifier. Therefore a brief description of SCRs is surely needed.

Thyristors are electronic switches used in some power electronic circuits where control of switch turn on is required. The term thyristor often refers to a family of three terminal devices that includes the silicon-controlled rectifier, the triac, the GTO, MCT and others. Thyristor and SCR are sometimes used simultaneously. Recently, some manufacturers have developed thyristors using Silicon Carbide (SiC) as the semiconductor material which are able to operate in high temperature environments, capable of operating at temperatures up to 350°C [5].

Thyristors are capable of large currents and large blocking voltages for use in high power applications. Some of the common applications are jotted below.

- AC power control (including lights, motors, etc.)
- Overvoltage protection crowbar for power supply
- AC power switching
- Control elements in phase angle triggered controllers
- Within photographic flashlights where they act as the switch to discharge a stored voltage through the flash lamp, and then cut it off at the required time

Thyristors are able to switch high voltages and withstand reverse voltages making them ideal for switching applications, especially in high voltage transmission systems. Modern

thyristors are able to switch power on the scale of megawatts, thus becoming the heart of HVDC transmission from or to Alternating Current (AC). For today's high power applications both electrically triggered (ETT) and light triggered (LTT) thyristors are profoundly used. Thyristors are arranged into a diode bridge circuit and to reduce harmonics are connected in series to form a 12 pulse converter. Each thyristor is cooled with deionized water, and the entire arrangement becomes one of multiple identical modules forming a layer in a multilayer valve stack which is called a quadruple valve. Three such stacks are typically mounted on the floor or hung from the ceilings of the valve hall of a long-distance transmission facility.

2.2 Operation of SCR

The three terminals of the SCR are the anode, cathode and gate. For the SCR to begin to conduct, it must have a gate current applied while it has a positive anode-to-cathode voltage. After conduction is established, the gate signal is no longer required to maintain anode current. The SCR will continue to conduct as long as the anode current remains positive and above a minimum value called the holding level.

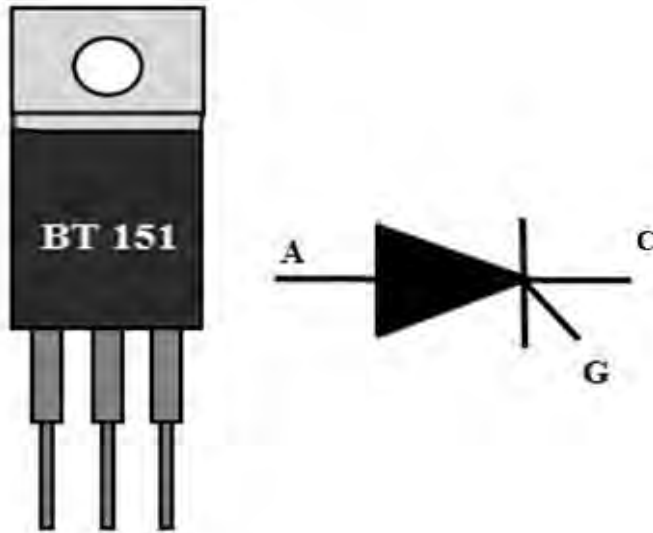

Fig: 2.2.1 Silicon Controlled Rectifier(SCR) [8]

The gate terminal connects directly to the base of the lower transistor; it may be used as an alternative means to latch the SCR. By applying a small voltage between gate and cathode, the lower transistor will be forced on by the resulting base current, which will cause the upper transistor to conduct, which then supplies the lower transistor's base with current so that it no longer needs to be activated by a gate voltage. The necessary gate current to initiate latch-up, of course, will be much lower than the current through the SCR from cathode to anode, so the SCR does achieve a measure of amplification.

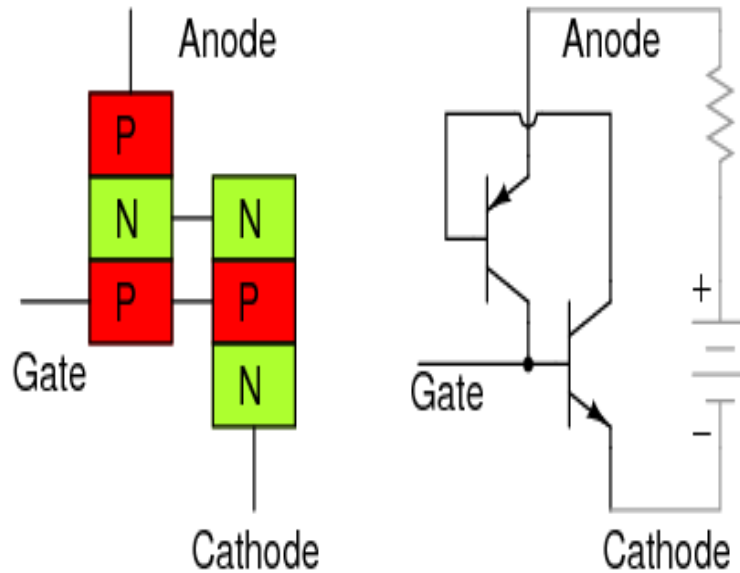

Fig: 2.2.2 BJT equivalent circuit [9]

This method of securing SCR conduction is called triggering, and it is by far the most common way that SCRs are latched in actual practice. In fact, SCRs are usually chosen so that their break over voltage is far beyond the greatest voltage expected to be experienced from the power source, so that it can be turned on only by an intentional voltage pulse applied to the gate.

It should be mentioned that SCRs may sometimes be turned off by directly shorting their gate and cathode terminals together, or by “reverse-triggering”

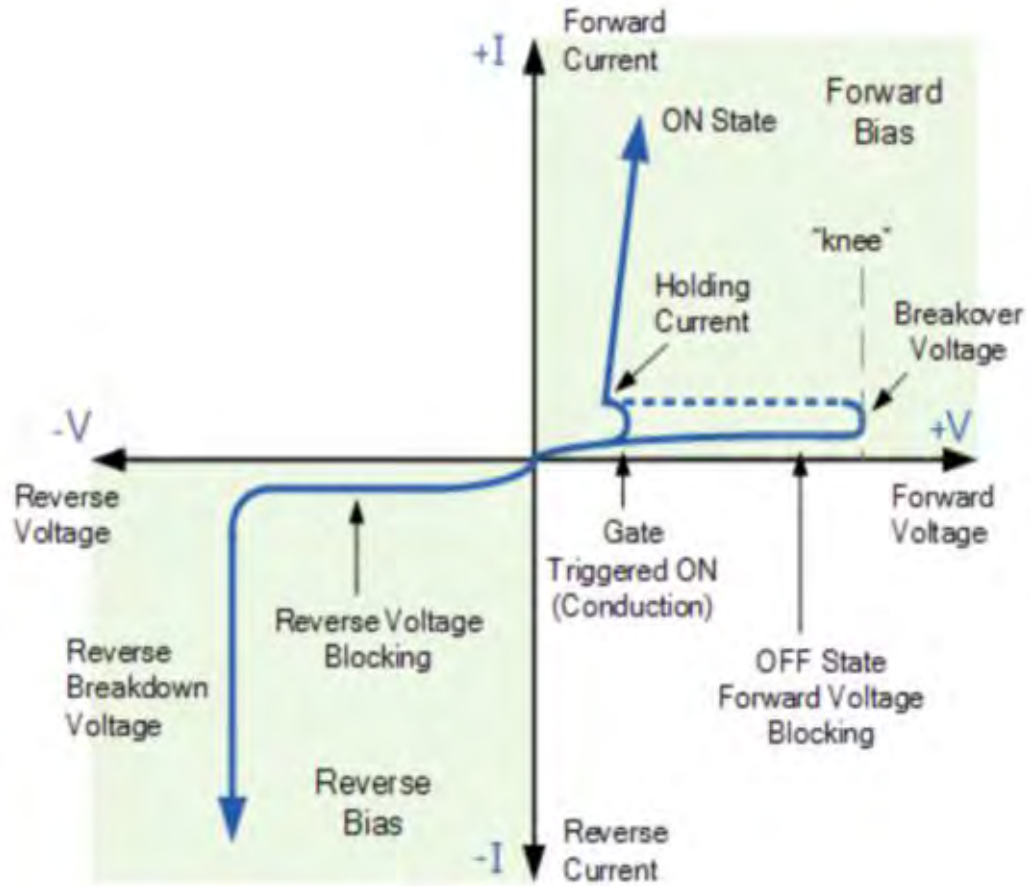

Fig: 2.2.3 V-I Characteristics of SCR [10]

the gate with a negative voltage (in reference to the cathode), so that the lower transistor is forced into cutoff.

A rudimentary test of SCR function, or at least terminal identification, may be performed with an ohmmeter. Because the internal connection between gate and cathode is a single PN junction, a meter should indicate continuity between these terminals with the red test lead on the gate and the black test lead on the cathode.

If we use a multimeter, to simply diode check we will find that the gate to cathode voltage is 0.7 which is typical silicon diode voltage. Sometimes this internal voltage may be very small. This is due to the internal resistance of the SCR which is attached to avoid false triggering by spurious voltage spikes, from circuit “noise” or from static electric discharge. This feature is often found in larger SCRs, not on small SCRs. An SCR with an internal resistor connected between gate and cathode will indicate continuity in both directions between those two terminals i.e. gate and cathode. “Normal” SCRs, lacking this internal resistor, are sometimes referred to as sensitive gate SCRs due to their ability to be triggered by the slightest positive gate signal.

A certain minimum amount of load current is required to hold the SCR latched in the “on” state. This minimum current level is called the holding current. A load with too great a resistance value may not draw enough current to keep an SCR latched when gate current ceases, thus giving the false impression of a bad (unlatchable) SCR in the test circuit. Holding current values for different SCRs should be available from the manufacturers. Typical holding current values range from 1 milliamp to 50 milliamps or more for larger units [6].

The forward break over voltage limit of the SCR could be tested by increasing the DC voltage supply until the SCR latches all on its own. A break over test may require very high voltage: many power SCRs have break over voltage ratings of 600 volts or more

2.3 Three Phase Fully Controlled Rectifier

The operation of a 3-phase fully-controlled bridge rectifier circuit is described in this page. A three-phase fully-controlled bridge rectifier can be constructed using six SCRs as shown below.

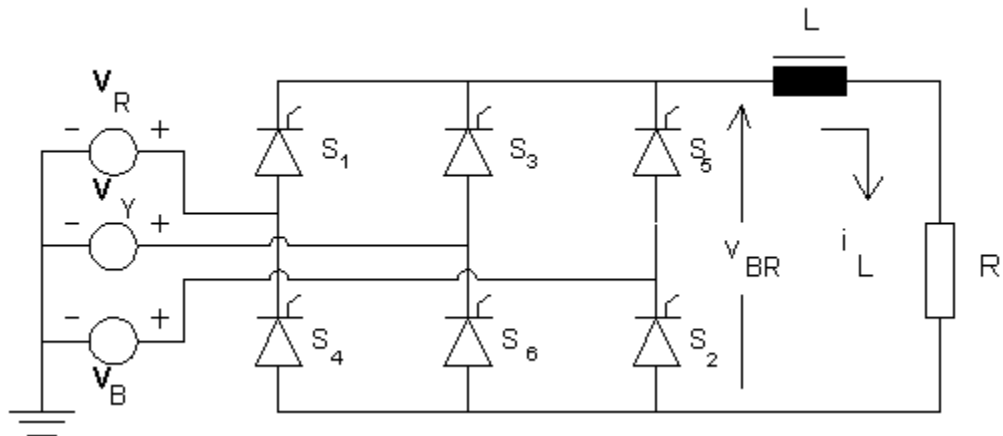

Fig 2.3 Three Phase Fully Controlled Rectifier [5]

The three-phase bridge rectifier circuit has three-legs, each phase connected to one of the three phase voltages. Alternatively, it can be seen that the bridge circuit has two halves, the positive half consisting of the SCRs S_1 , S_3 and S_5 and the negative half consisting of the SCRs S_2 , S_4 and S_6 . At any time when there is current flow, one SCR from each half conducts. If the phase sequence of the source be RYB, the SCRs are triggered in the sequence S_1 , S_2 , S_3 , S_4 , S_5 , S_6 and S_1 and so on.

The operation of the circuit is first explained with the assumption that diodes are used in place of the SCRs. The three-phase voltages vary as shown below.

$$v_R(\theta) = E * \sin(\theta)$$

$$v_Y(\theta) = E * \sin(\theta - 120^\circ)$$

$$v_B(\theta) = E * \sin(\theta + 120^\circ)$$

It can be seen that the R-phase voltage is the highest of the three-phase voltages when θ is in the range from 30° to 150° . It can also be seen that Y-phase voltage is the highest of the three-phase voltages when θ is in the range from 150° to 270° and that B-phase voltage is the highest of the three-phase voltages when θ is in the range from 270° to 390° or 30° in the next cycle. We also find that R-phase voltage is the lowest of the three-phase voltages when θ is in the range from 210° to 330° . It can also be seen that Y-phase voltage is the lowest of the three-phase voltages when θ is in the range from 330° to 450° or 90° in the next cycle, and that B-phase voltage is the lowest when θ is in the range from 90° to 210° . If diodes are used, diode D_1 in place of S_1 would conduct from 30° to 150° , diode D_3 would conduct from 150° to 270° and diode D_5 from 270° to 390° or 30° in the next cycle. In the same way, diode D_4 would conduct from 210° to 330° , diode D_6 from 330° to 450° or 90° in the next cycle, and diode D_2 would conduct from 90° to 210° . The positive rail of output voltage of the bridge is connected to the topmost segments of the envelope of three-phase voltages and the negative rail of the output voltage to the lowest segments of the envelope.

At any instant barring the change-over periods when current flow gets transferred from diode to another, only one of the following pairs conducts at any time.

Table: 2.3.1 Diodes and firing angles [5]

Period, range of θ	Diode Pair in conduction
30° to 90°	D_1 and D_6
90° to 150°	D_1 and D_2
150° to 210°	D_2 and D_3
210° to 270°	D_3 and D_4
270° to 330°	D_4 and D_5
330° to 360° and 0° to 30°	D_5 and D_6

If SCRs are used, their conduction can be delayed by choosing the desired firing angle. When the SCRs are fired at 0° firing angle, the output of the bridge rectifier would be the same as that of the circuit with diodes. For instance, it is seen that D_1 starts conducting only after $\theta = 30^\circ$. In fact, it can start conducting only after $\theta = 30^\circ$, since it is reverse-biased before $\theta = 30^\circ$. The bias across D_1 becomes zero when $\theta = 30^\circ$ and diode D_1 starts getting forward-biased only after $\theta = 30^\circ$. When $V_R(\theta) = E \cdot \sin(\theta)$, diode D_1 is reverse-biased before $\theta = 30^\circ$ and it is forward-biased when $\theta > 30^\circ$. When firing angle to SCRs is zero degree, S_1 is triggered when $\theta = 30^\circ$. This means that if a synchronizing signal is needed for triggering S_1 , that signal voltage would lag $V_R(\theta)$ by 30° and if the firing angle is α , SCR S_1 is triggered when $\theta = \alpha + 30^\circ$. Given that the conduction is continuous, the following table presents the SCR pair in conduction at any instant.

Table: 2.3.2 Switches and angles [5]

Period, range of θ	SCR Pair in conduction
$\alpha + 30^\circ$ to $\alpha + 90^\circ$	S_1 and S_6
$\alpha + 90^\circ$ to $\alpha + 150^\circ$	S_1 and S_2
$\alpha + 150^\circ$ to $\alpha + 210^\circ$	S_2 and S_3
$\alpha + 210^\circ$ to $\alpha + 270^\circ$	S_3 and S_4
$\alpha + 270^\circ$ to $\alpha + 330^\circ$	S_4 and S_5
$\alpha + 330^\circ$ to $\alpha + 360^\circ$ and $\alpha + 0^\circ$ to $\alpha + 30^\circ$	S_5 and S_6

The operation of the bridge-rectifier is illustrated with the help of an applet that follows this line. You can set the firing angle in the range $0^\circ < \text{firing angle} < 180^\circ$ and the instantaneous angle. The applet displays the SCR pair in conduction at the chosen instant. The instantaneous angle can be either set in its text-field or varied by dragging the scroll-bar button. The rotating phasor diagram is quite useful to illustrate how the circuit operates. Once the firing angle is set, the phasor position for firing angle is fixed. Then as the instantaneous angle changes, the pair that conducts is connected to the thick orange arcs.

One way to visualize is to imagine two brushes which are 120° wide and the device in the phase connected to the brush conducts. The brush that has "Firing angle " written beside it acts as the brush connected to the positive rail and the other acts as if it is connected to the negative rail. This diagram illustrates how the rectifier circuit acts as a commutator and converts ac to dc. The output voltage is specified with the amplitude of the phase voltage, which is being assigned by the unity value.

2.4 SYNCHRONIZING SIGNALS

To vary the output voltage, it is necessary to vary the firing angle. In order to vary the firing angle, one commonly used technique is to establish a synchronizing signal for each SCR. It has been seen that zero degree firing angle occurs 30° degrees after the zero-crossing of the respective phase voltage. If the synchronizing signal is to be a sinusoidal signal, it should lag the respective phase by 30° and then the circuitry needed to generate a firing signal can be similar to that described for single-phase. Instead of a single such circuit for a single phase rectifier, we would need three such circuits.

The line voltage can also be obtained as:

$$\begin{aligned}
 v_{RB}(\theta) &= v_R(\theta) - v_B(\theta) \\
 &= E * \sin \theta - E * \sin(\theta + 120) \\
 &= E * \sin(\theta) + \frac{E}{2} * \sin(\theta) - \frac{\sqrt{3}E}{2} * \cos(\theta) \\
 &= \sqrt{3}E * \sin(\theta - 30)
 \end{aligned}$$

This line voltage lags the R-phase voltage by 30° and has amplitude which is 1.732 times the amplitude of the phase voltage. The synchronizing signal for SCR S_1 can be obtained based on V_{RB} line voltage. The synchronizing signals for the other SCRs can be obtained in a similar manner.

To get the synchronizing signals, three control transformers can be used, with the primaries connected in delta and the secondaries in star.

2.4 MATHEMATICAL ANALYSIS

Analysis of this three-phase controlled rectifier is in many ways similar to the analysis of single-phase bridge rectifier circuit. We are interested in output voltage and the source current. The average output voltage, the rms output voltage, the ripple content in output voltage, the total rms line current, the fundamental rms current, THD in line current, the displacement power factor and the apparent power factor are to be determined. In this section, the analysis is carried out assuming that the load current is a steady dc value.

2.5 AVERAGE OUTPUT VOLTAGE

Before getting an expression for the output voltage, it is preferable to find out how the output voltage waveform varies as the firing angle is varied. In one cycle of source voltage, six pairs conduct, each pair for 60° . This means that the period for output waveform is one-sixth of the period of line voltage. The output waveform repeats itself six times in one cycle of input voltage. The waveform of output voltage can be determined by considering one pair. It is seen that when $V_R(\theta) = E^* \sin(\theta)$, SCR S_1 and S_6 conduct when θ varies from $30^\circ + \alpha$ to $90^\circ + \alpha$, where α is the firing angle.

$$\begin{aligned}
v_o(\theta) &= v_R(\theta) - v_r(\theta) \\
&= E * \sin(\theta) - E * \sin(\theta - 120^\circ) \\
&= \sqrt{3}E * \sin(\theta + 30^\circ), \text{ for } (\alpha + 30^\circ) < \theta < (\alpha + 90^\circ)
\end{aligned}$$

Then the waveform of output can be plotted for different firing angles. The applet below takes in the firing angle as an input and plots the output. The peak line-to-line voltage is marked as 'U' and the applet starts with the instant an SCR is fired and displays the output waveform for one input cycle period. The average output voltage of the bridge circuit is calculated as follows, with a change in variable, where $\theta = \alpha + 60^\circ$.

$$v_{o,avg}(\alpha) = \frac{\sqrt{3}E}{\pi/3} \int_{\alpha+\pi/3}^{\alpha+(2\pi)/3} \sin(\theta).d\theta = \frac{3}{\pi}U * \cos(\alpha)$$

In the expression above, U is the peak line-to-line voltage, whereas E is the amplitude of phase voltage of 3-phase supply.

2.6 RMS OUTPUT VOLTAGE

The rms output voltage is calculated as follows:

$$V_{o,rms}(\alpha) = U * \sqrt{(V_{o,rms}(\alpha))^2 - (V_{o,avg}(\alpha))^2}$$

The ripple factor of the output voltage is then:

$$RF(\alpha) = \frac{1}{V_{o,avg}(0^\circ)} * \sqrt{(V_{o,rms}(\alpha))^2 - (V_{o,avg}(\alpha))^2}$$

It is seen that the average output voltage is negative when firing angle exceeds 90° . It means that power flow is from the dc side to the ac source. When the firing angle is kept in the region $0^\circ < \alpha < 90^\circ$, this circuit is said to be operating in the **rectifier region**. When the firing angle is kept in the region $90^\circ < \alpha < 180^\circ$, this circuit is said to be operating in the **inverter region**. When the circuit operates in the rectifier region, the net power flow is from the ac source to the dc link. In the inverter region, the net power flow is in the reverse direction. To operate in the inverter region, it is necessary to have a dc source present in the dc link which can provide the power that is fed back to the ac source [5].

2.7 RMS LINE CURRENT

The rms line current is relatively easy to find out if the dc current is ripple-free and steady. The load current is ripple-free if the inductance in the dc link is relatively large. To maintain load current at any firing angle, it is necessary that the dc link should contain a voltage source. Given that the resistance of the load circuit is zero, the voltage source should equal the average output voltage of the bridge circuit.

The waveforms shown below are based on the assumption that these conditions are met. It has been shown that if $V_R(\theta) = E \cdot \sin(\theta)$, SCR S_1 conducts when θ varies from $\alpha + 30^\circ$ to $\alpha + 90^\circ$ and that SCR S_4 conducts when θ varies from $\alpha + 210^\circ$ to $\alpha + 270^\circ$. If the amplitude of dc load current is assigned to be unity, the line current waveform is then a rectangular pulse, remaining at +1 from $\alpha + 30^\circ$ to $\alpha + 150^\circ$, at -1 from $\alpha + 210^\circ$ to $\alpha + 330^\circ$, and zero elsewhere. The amplitude of the fundamental in line current is then $3.464/\pi$ (which evaluates to nearly 0.78) and the amplitude of other odd harmonics is $3.464/n\pi$, where n is the odd harmonic number. When the line current is a rectangular and symmetric, the phase current is the same as the line current and the fundamental component of the phase current lags the phase voltage by an angle equal to the firing angle.

Hence the displacement power factor is expressed. Since the line current is not sinusoidal, the apparent power factor, usually referred to just as the power factor in most of the texts, is less than DPF. Since the line current is not sinusoidal, the distortion

component in the line current has to be computed. This component, called the THD (Total Harmonic Distortion), is calculated as shown in the equation below.

$$I_{rms} = \sqrt{\frac{1}{\pi} * \int_{\frac{\pi}{6}}^{\frac{5\pi}{6}} d\theta} = 0.816$$

$$I_{1,rms} = \frac{4}{\sqrt{2}\pi} * \int_{\frac{\pi}{6}}^{\frac{\pi}{2}} \text{Sin}(\theta) d\theta = 0.7797$$

$$DPF = \text{Cos}(\alpha)$$

$$\text{Apparent PF} = \frac{I_{1,rms}}{I_{rms}} * DPF = 0.9555 * \text{Cos}(\alpha)$$

$$THD = \sqrt{\frac{(I_{rms})^2}{(I_{1,rms})^2} - 1} = 0.311$$

The calculations and equations of thyristors are the basics and thus, quite important for HVDC Transmission systems. Therefore, the calculations should be done in care. Along with that, the understandings of these equations along with their applications play a vital role in HVDC Transmission system

CHAPTER 3

Simulation of SCR Controlled

Rectifier

Practically, we used switches in lieu of SCRs. As we know that SCRs i.e. thyristors are basically switches which controls the flow of current in a circuit. The schematics and the graphs are demonstrated below.

3.1 Ideal Circuit Setup using SCR (Schematics)

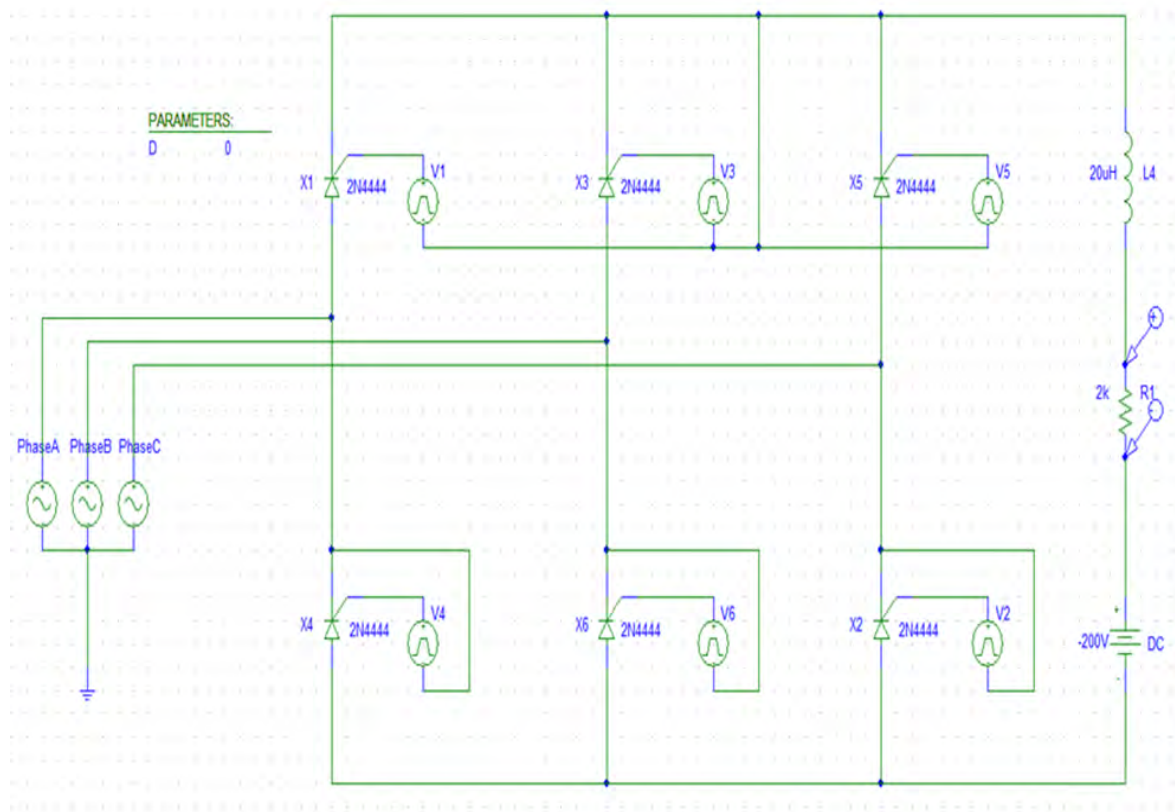

Fig: 3.1 6 pulse rectifier using SCR

Configurations:

Source Voltage:

Amplitude = 100V, Frequency = 50Hz

Pulse Voltage:

For all the pulses, common values are

V1=0V, V2 = 10V, Rise Time = 100ns, Fall Time = 100ns, Time Period = 20ms, Pulse Width = 0.5ms (Except X6, PW=5ms)

Time Delay

X1= $\{(D+30)/50/360\}$

X2= $\{(D+90)/50/360\}$

X3= $\{(D+150)/50/360\}$

X4= $\{(D+210)/50/360\}$

X5= $\{(D+270)/50/360\}$

X6= $\{(D+330)/50/360\}$

Transient Setup:

Print Step = 100us, Final Time = 50ms

Parametric Sweep:

Start Value = 0, End Value = 180, Increment = 15

Note:

Black and white graphs at the end (when Alpha Angle is more than 90O) are taken for the load side voltage source value of -200V whereas Color graphs are for load side voltage source value of -100V.

3.2 Practical 6 pulse circuit setup using Switches (Schematics)

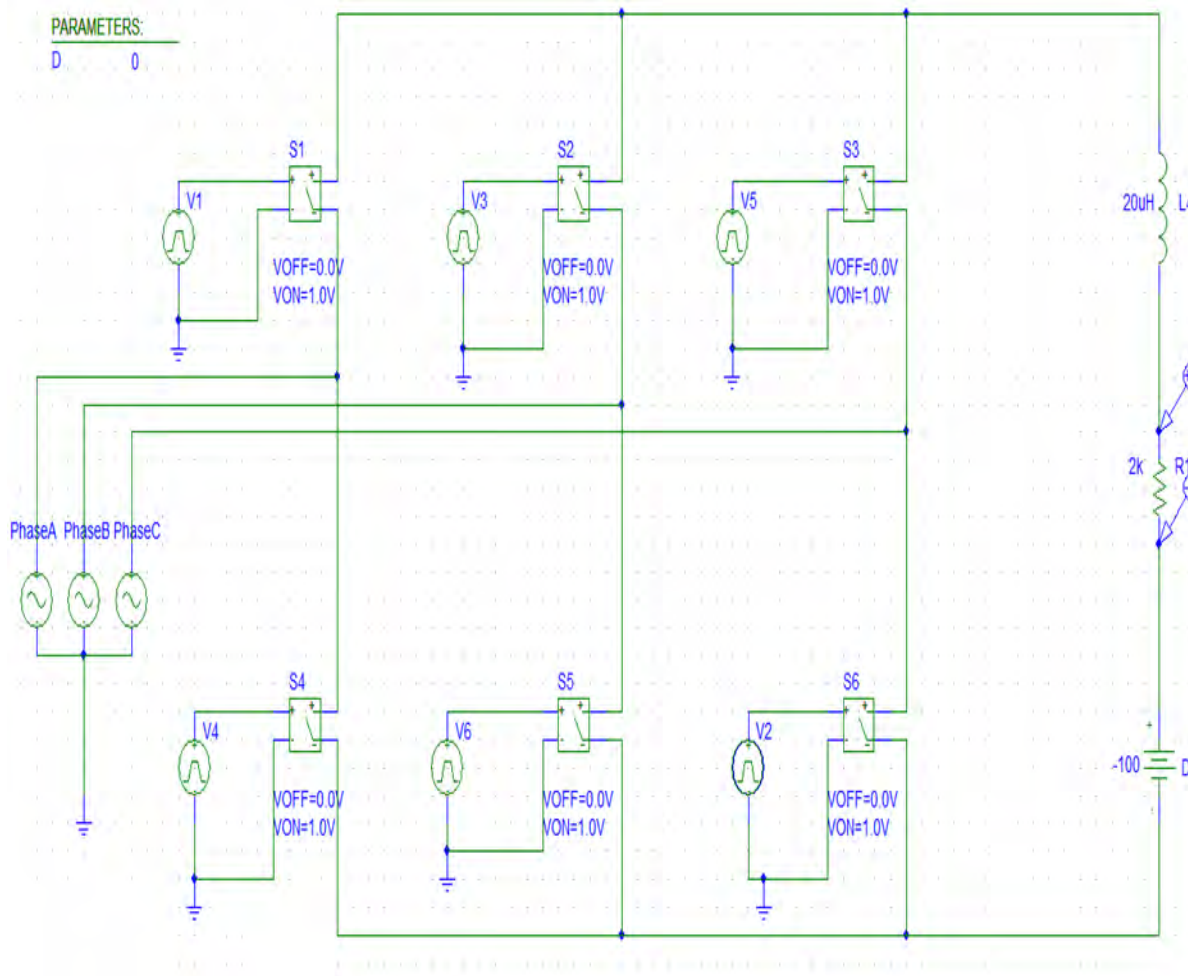

Fig: 3.2 6 pulse rectifier using Switches

Configurations:

Source Voltage:

Amplitude = 300V, Frequency = 50Hz

Pulse Voltage:

For all the pulses, common values are

V1=0V, V2 = 1V, Rise Time = 100ns, Fall Time = 100ns, Time Period = 20ms, Pulse Width = 6.67ms

Time Delay

$$X1 = \{(D+30)/50/360\}$$

$$X2 = \{(D+90)/50/360\}$$

$$X3 = \{(D+150)/50/360\}$$

$$X4 = \{(D+210)/50/360\}$$

$$X5 = \{(D+270)/50/360\}$$

$$X6 = \{(D+330)/50/360\}$$

Transient Setup:

Print Step = 0.2ms, Final Time = 50ms, No print delay = 20ms

Parametric Sweep:

Start Value = 0, End Value = 180, Increment = 15

3.3 Simulation Graphs – 6 pulse

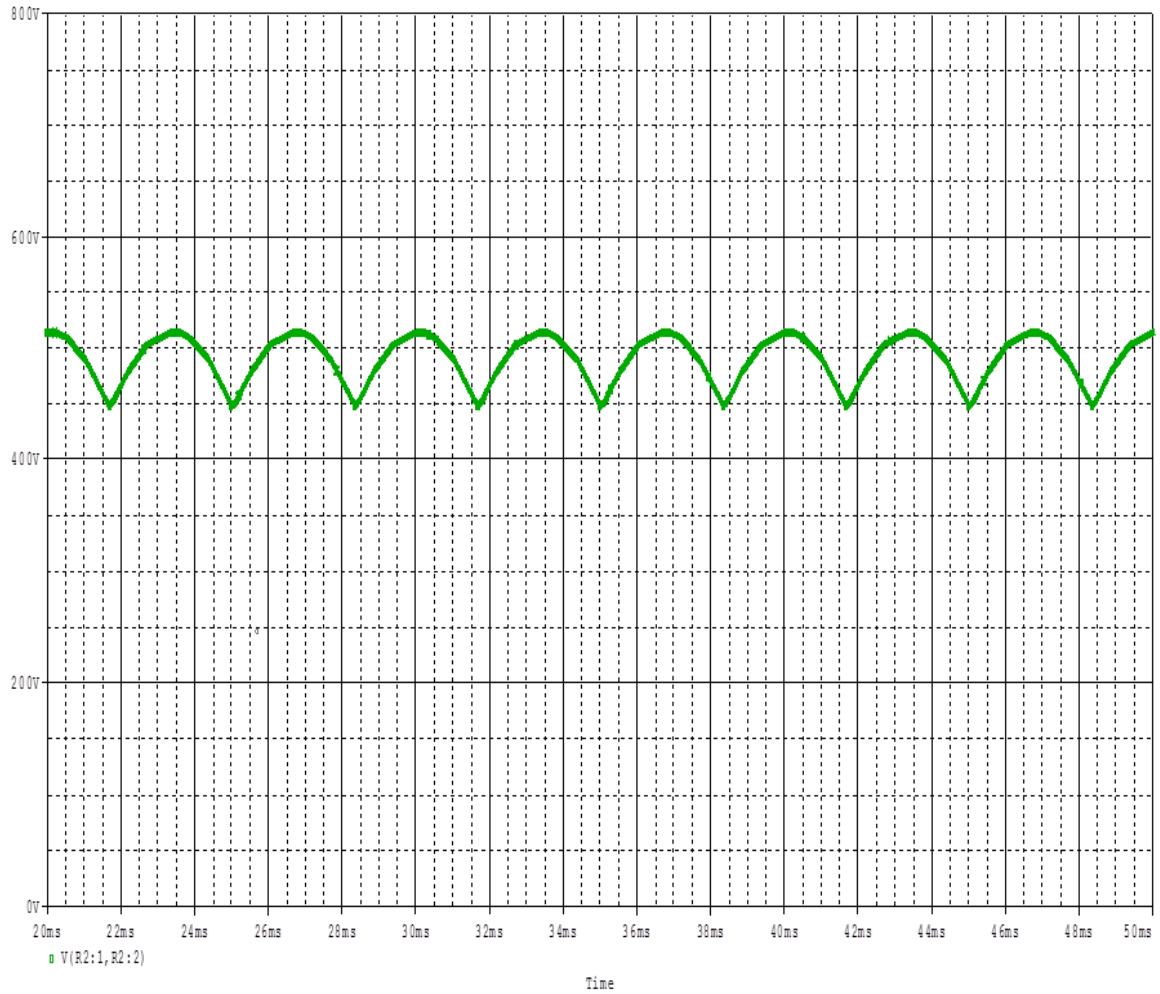

Fig 3.2.1: Output wave shape, $\alpha = 0^\circ$

In Fig 3.2.1 we can see that the firing angle (α) is 0. On that time, the average voltage will be highest in position. In this figure the average voltage is 480V.

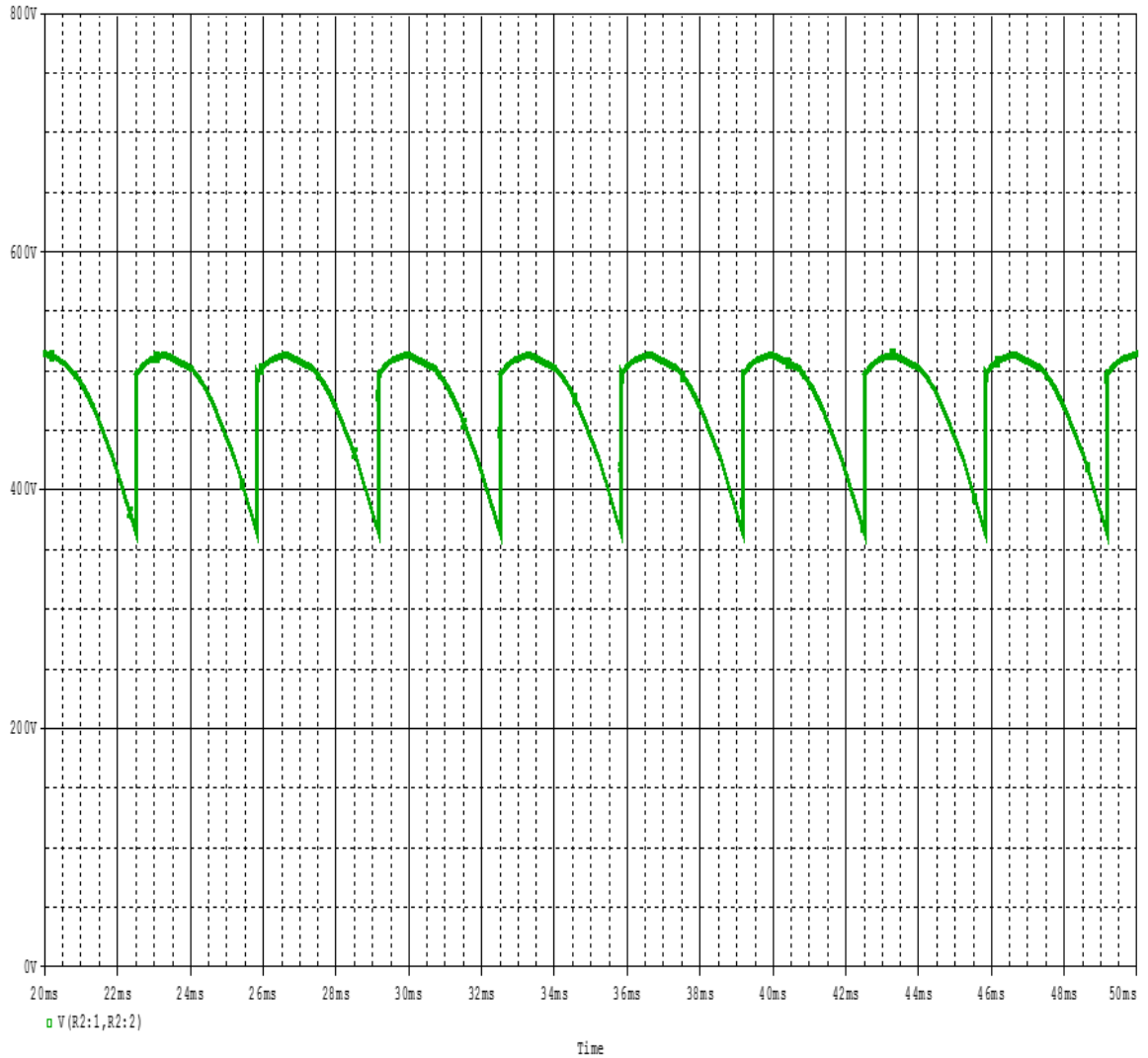

Fig: 3.2.2 Fig:3.2.1 Output wave shape, $\alpha = 15^\circ$

In Fig 3.2.2 we can see when the firing angle (α) is 15° . The average voltage will be lower than the average voltage of $\alpha = 0^\circ$. In this figure the average voltage is approximately 440V.

On the other hand from Fig 3.2.3 we can see when the firing angle (α) is 30° . The average voltage will be lower than the average voltage of $\alpha = 15^\circ$. In this figure the average voltage is approximately 385V.

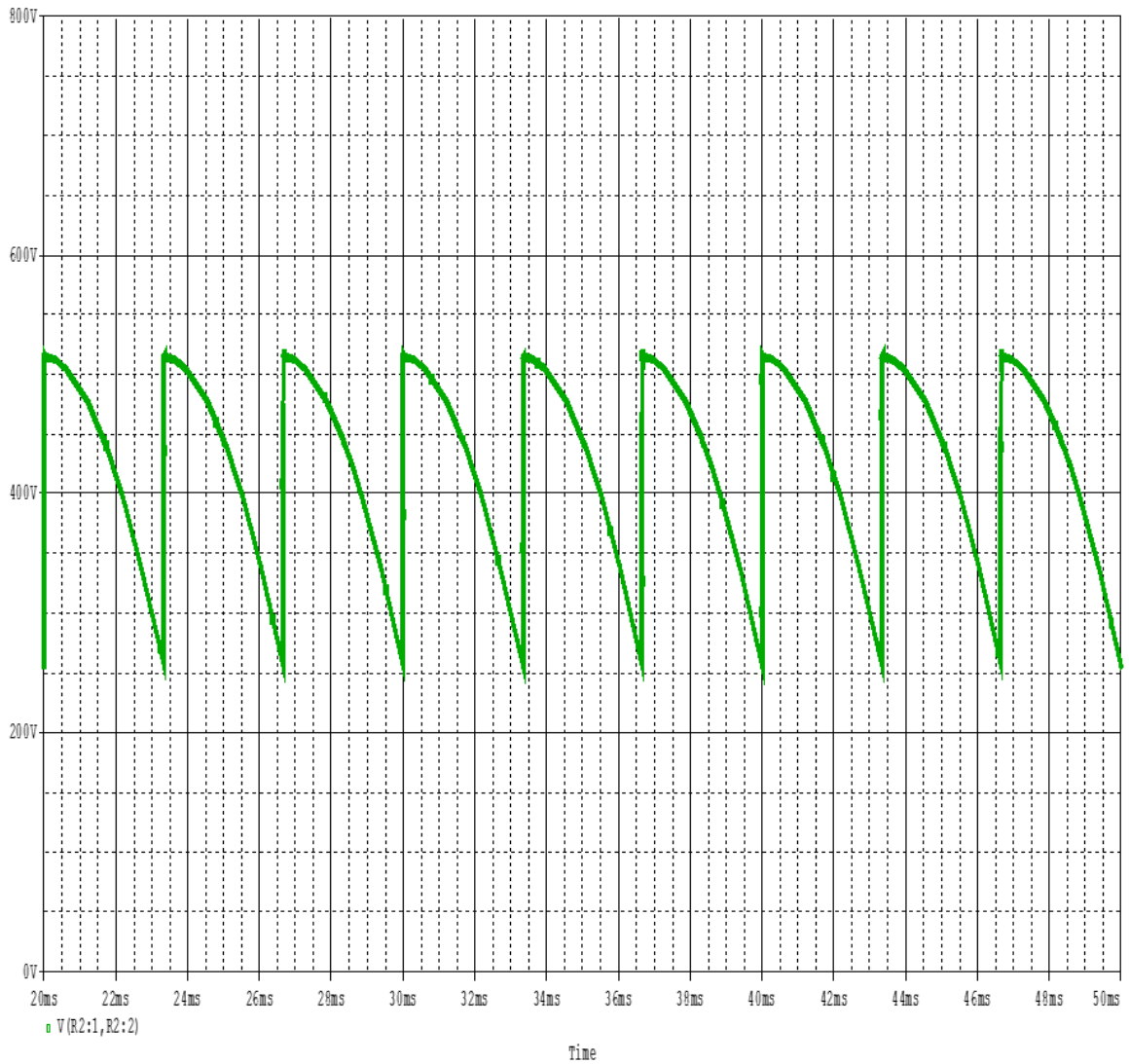

Fig: 3.2.3 Output wave shape, $\alpha = 30^\circ$

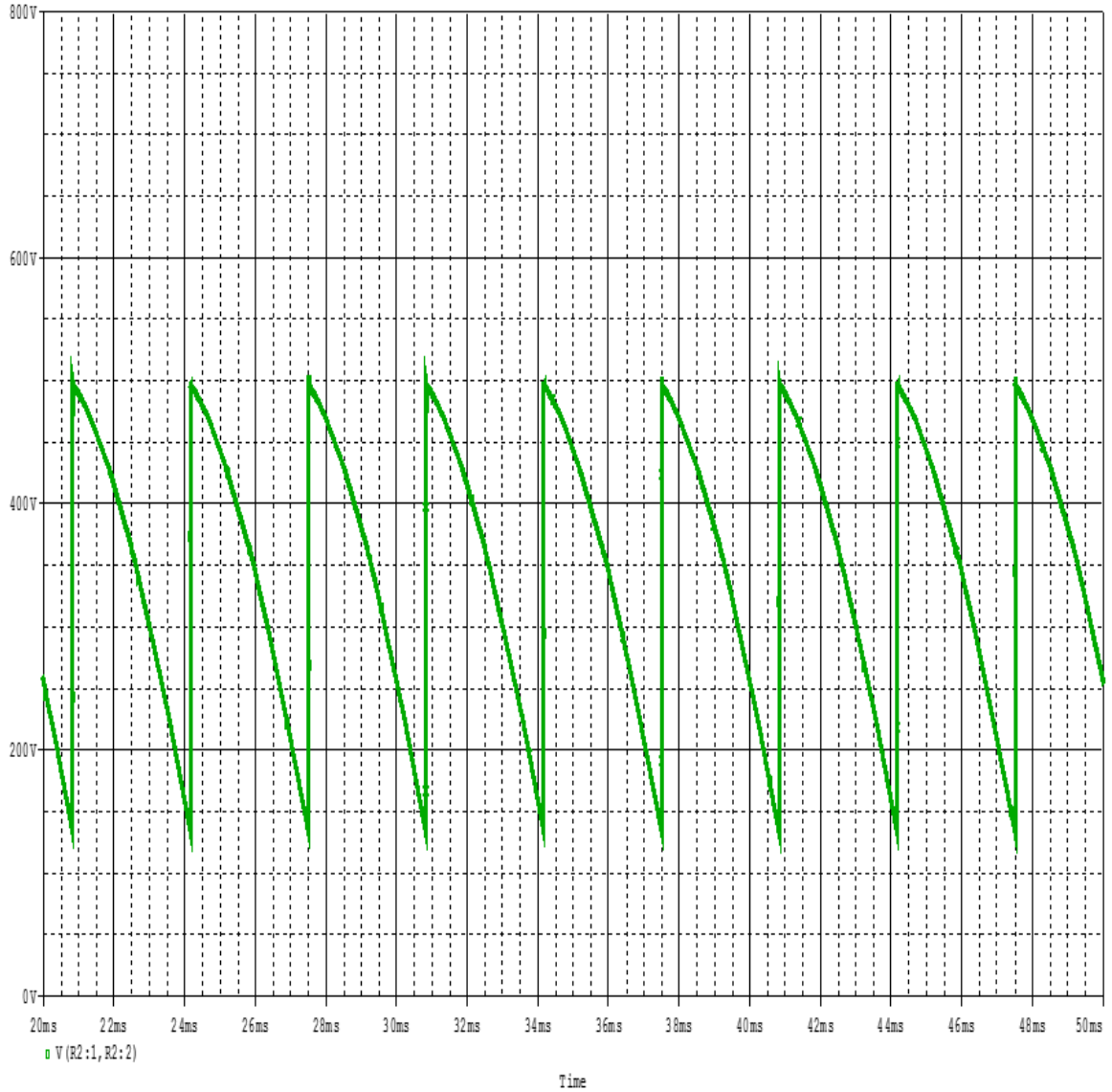

Fig: 3.2.4 Output wave shape, $\alpha = 45^\circ$

In Fig 3.2.4 we can see when the firing angle (α) is 45° . The average voltage will be lower than the average voltage of $\alpha = 30^\circ$. In this figure the average voltage is approximately 315V.

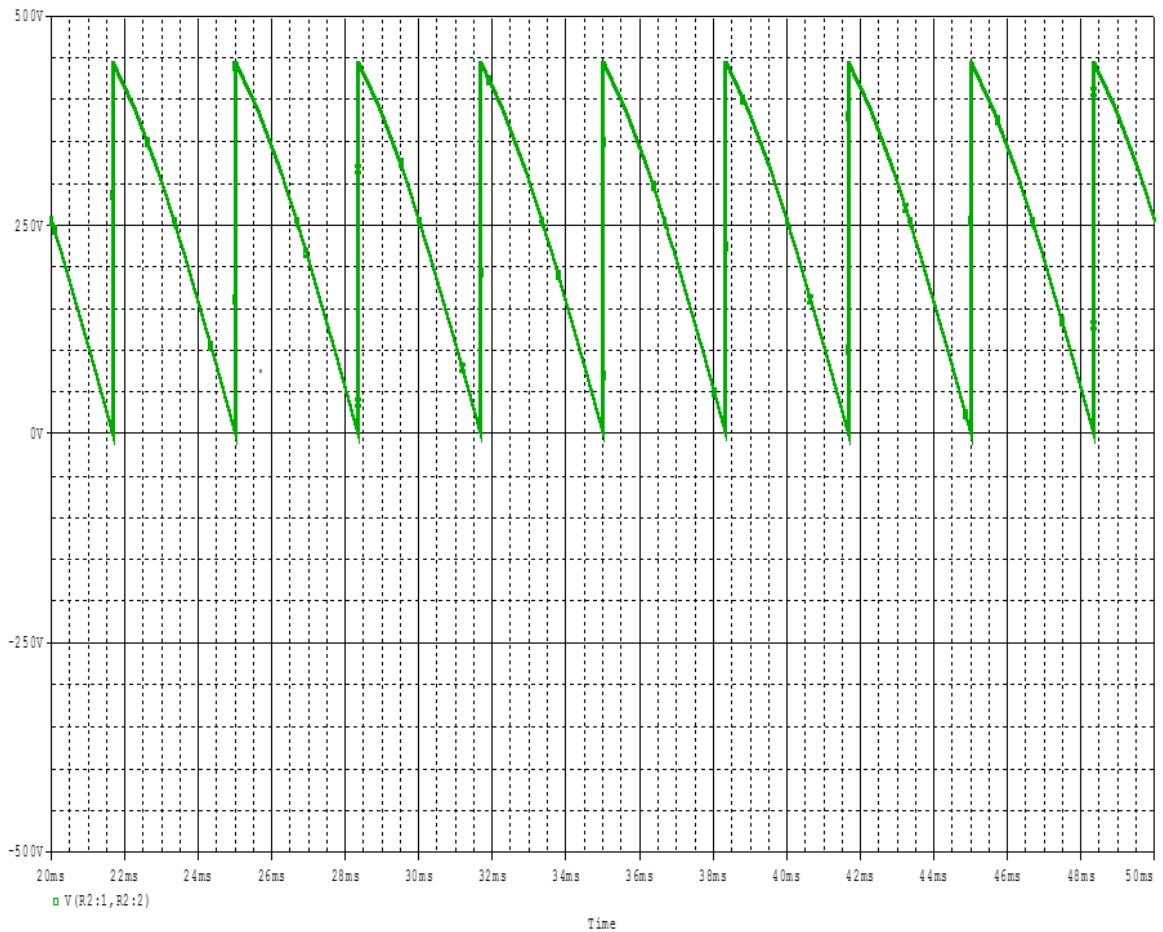

Fig: 3.2.5 Output wave shape, $\alpha = 60^\circ$

In Fig 3.2.5 we can see when the firing angle (α) is 60° . The average voltage will be lower than the average voltage of $\alpha = 45^\circ$. In this figure the average voltage is approximately 225V.

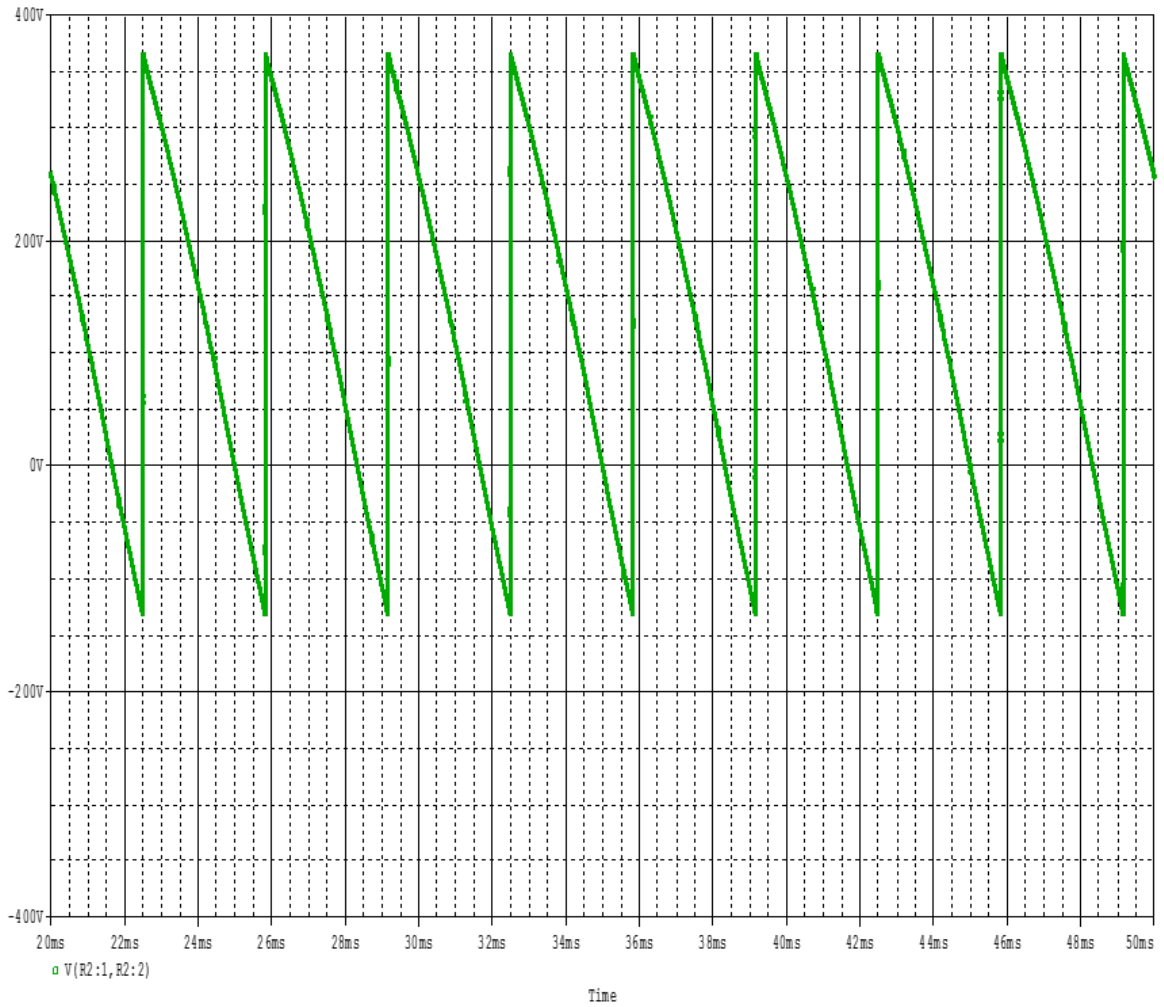

Fig: 3.2.6 Output wave shape, $\alpha = 75^\circ$

In Fig 3.2.6 we can see when the firing angle (α) is 75° . The average voltage will be lower than the average voltage of $\alpha = 60^\circ$. In this figure the average voltage is approximately 115V

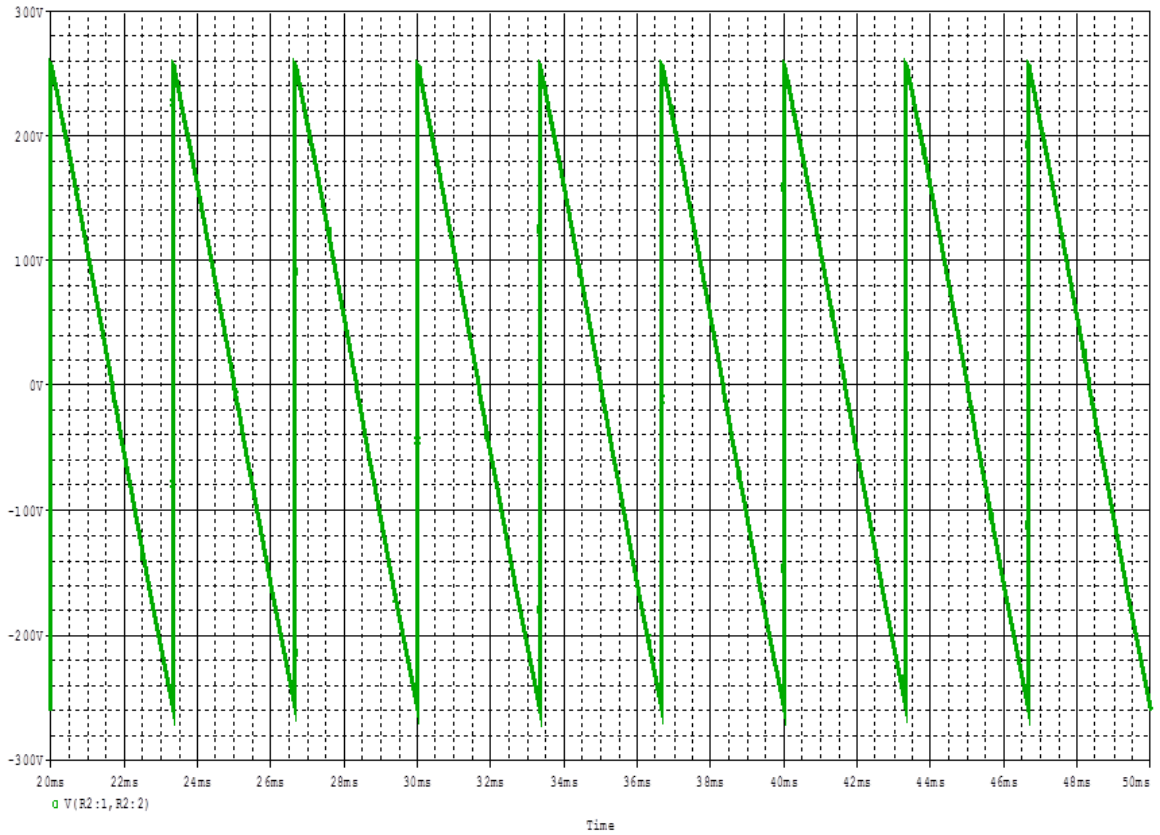

Fig: 3.2.7 Output wave shape, $\alpha = 90^\circ$

In Fig 3.2.7 when the firing angle (α) is 90° . There will be no average voltage. After this the average voltage will be negative.

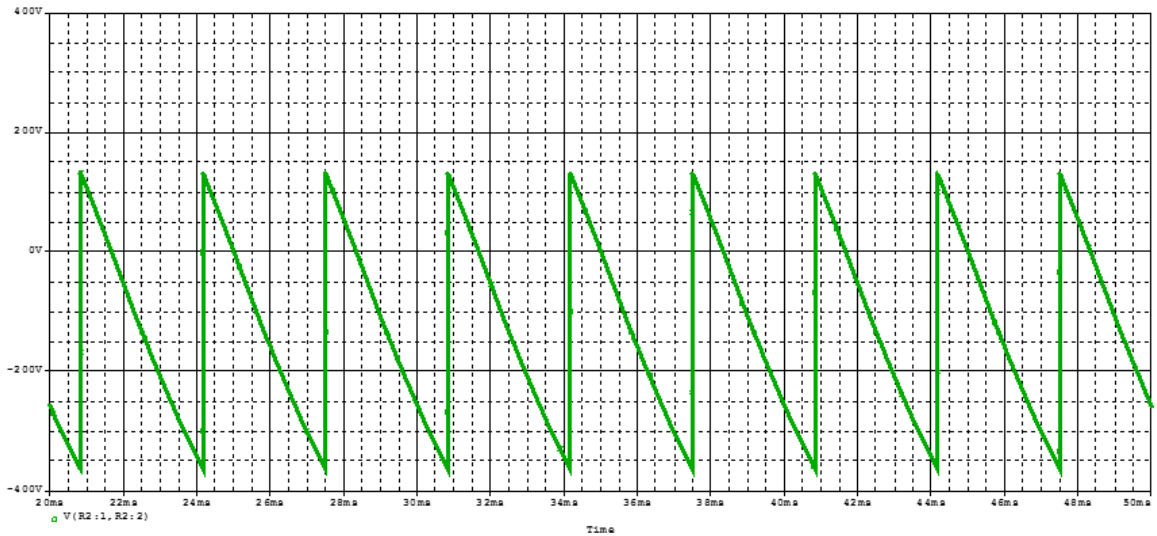

Fig: 3.2.8 Output wave shape, $\alpha = 105^\circ$

From the simulation output wave shape in Fig 3.2.8 we can see when the firing angle (α) is 105° . The average voltage will be negative. In this figure the average voltage is approximately -115V.

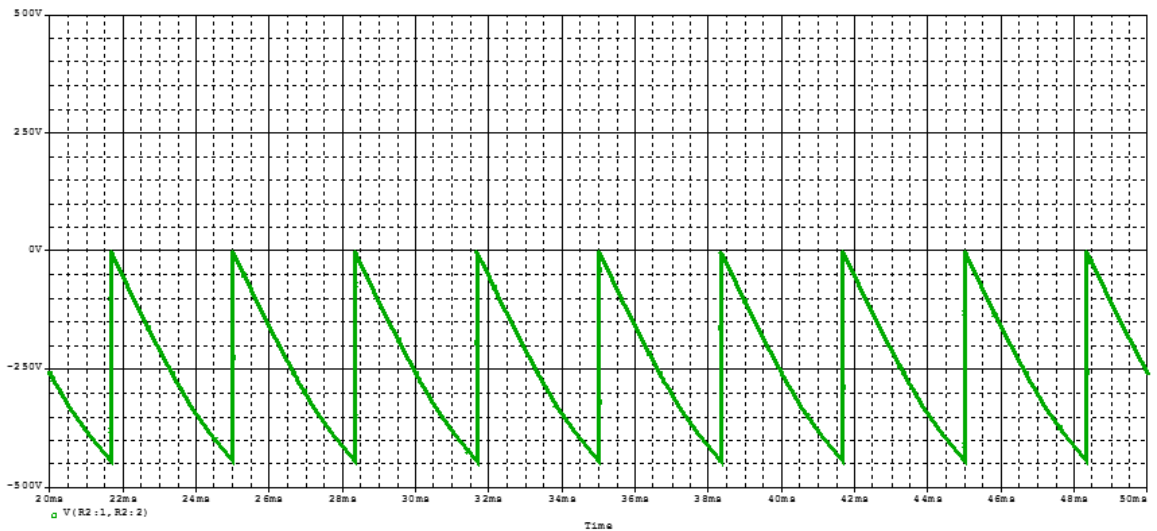

Fig: 3.2.9 Output wave shape, $\alpha = 120^\circ$

In Fig 3.2.9 firing angle (α) is 120° . The average voltage will be negative and the average voltage is approximately -225V.

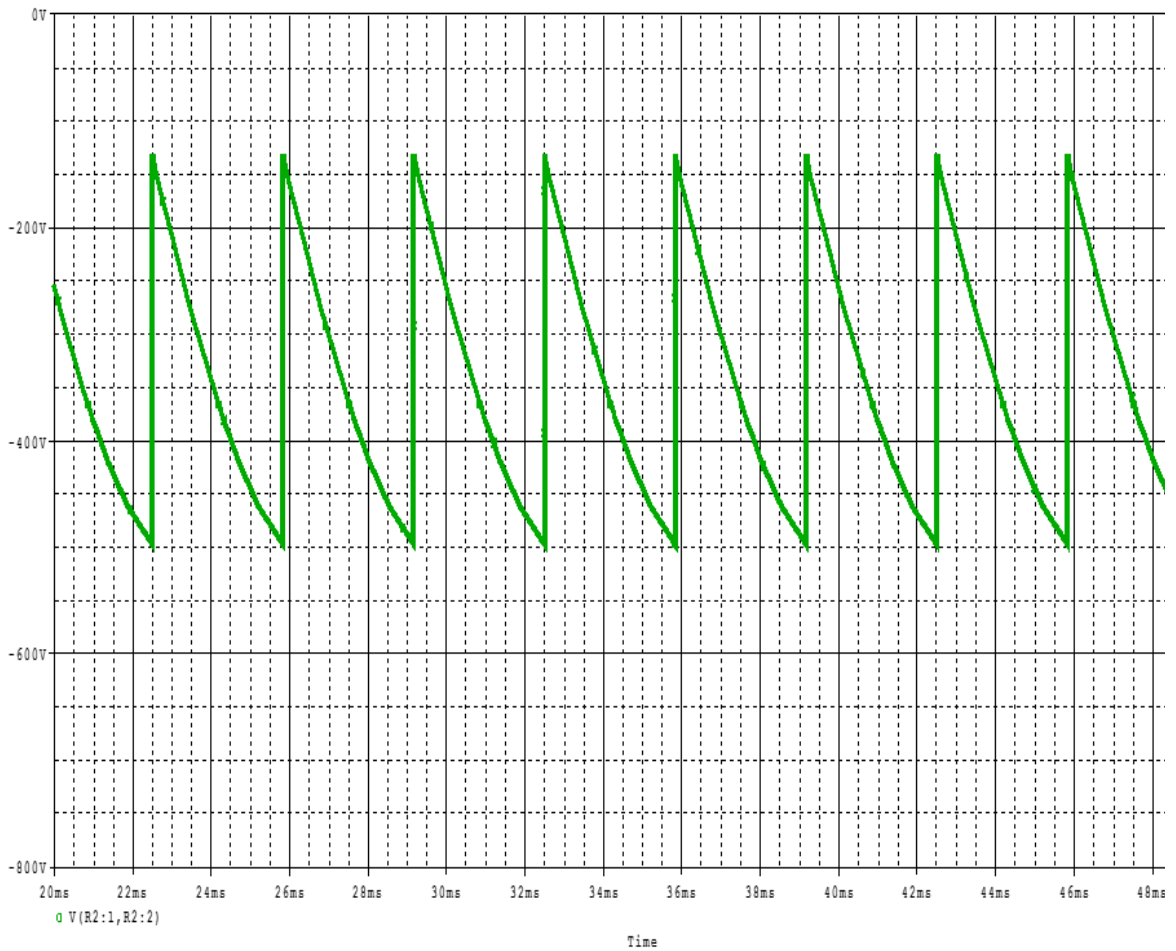

Fig: 3.2.10 Output wave shape, $\alpha = 135^\circ$

In Fig 3.2.10 we can see when the firing angle (α) is 135° . The average voltage will be lower than the average voltage of $\alpha = 120^\circ$. In this figure the average voltage is approximately -315V

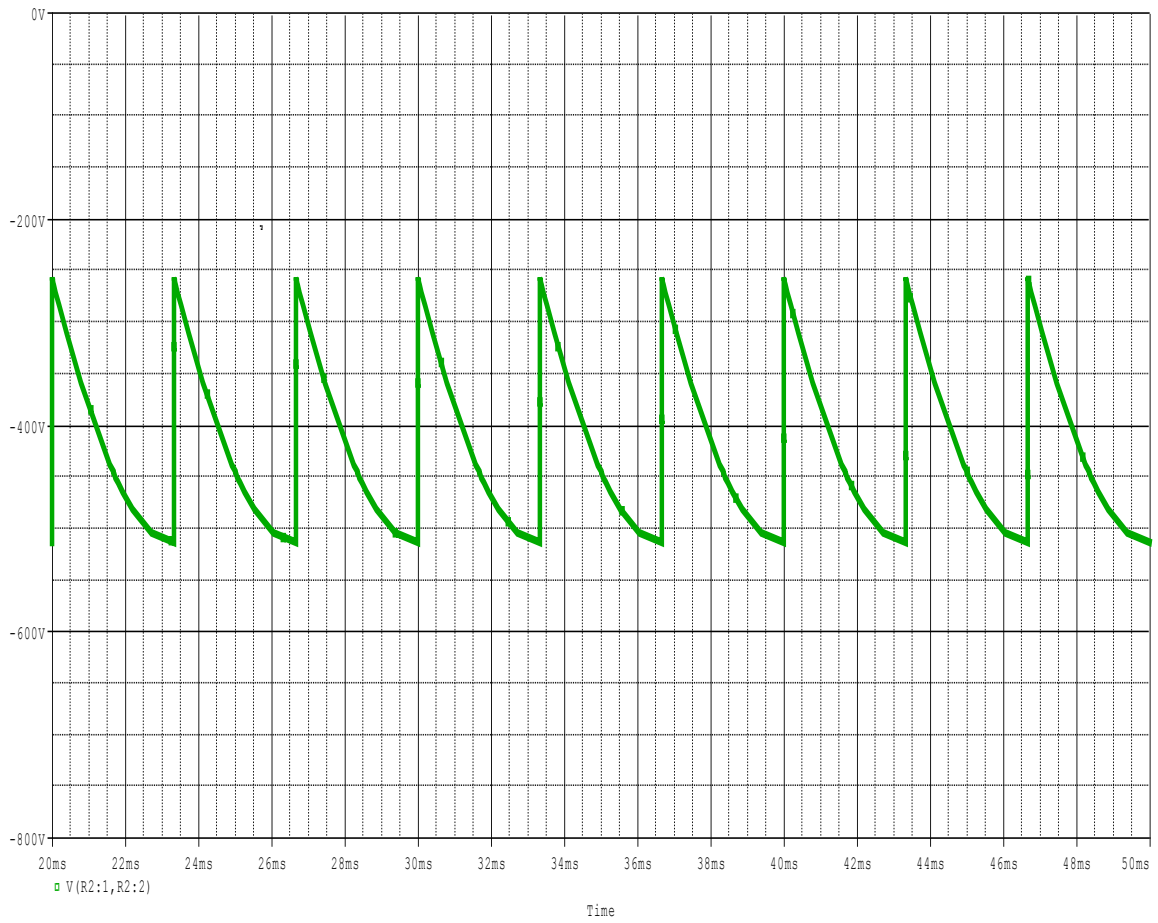

Fig: 3.2.11 Output wave shape, $\alpha = 150^\circ$

In Fig 3.2.11 we can see when the firing angle (α) is 135° . The average voltage will be lower than the average voltage of $\alpha = 120^\circ$. In this figure the average voltage is approximately -380V

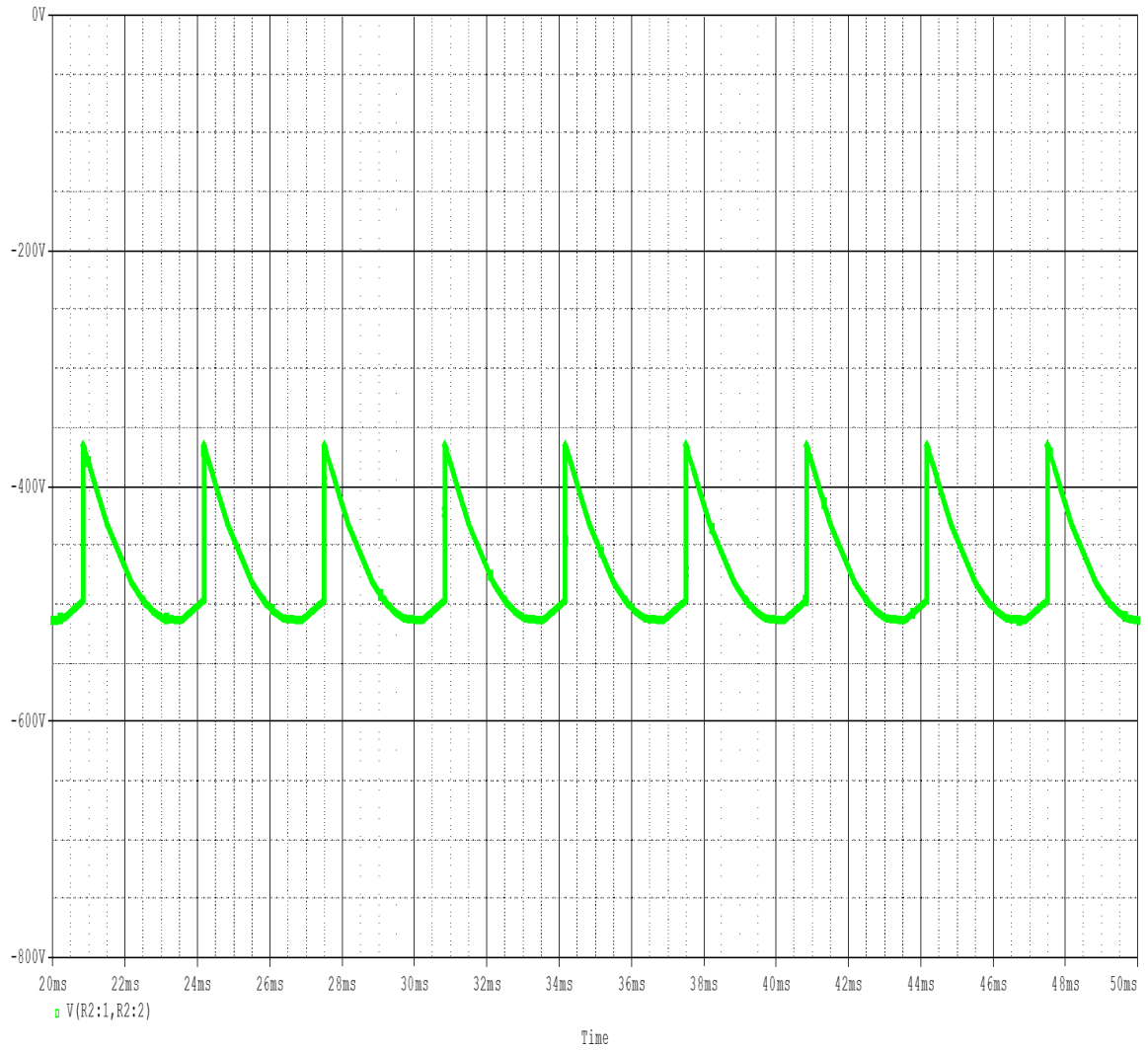

Fig: 3.2.12 Output wave shape, $\alpha = 165^\circ$

In Fig 3.2.11 we can see when the firing angle (α) is 165° . The average voltage will be lower than the average voltage of $\alpha = 150^\circ$. In this figure the average voltage is approximately -440V

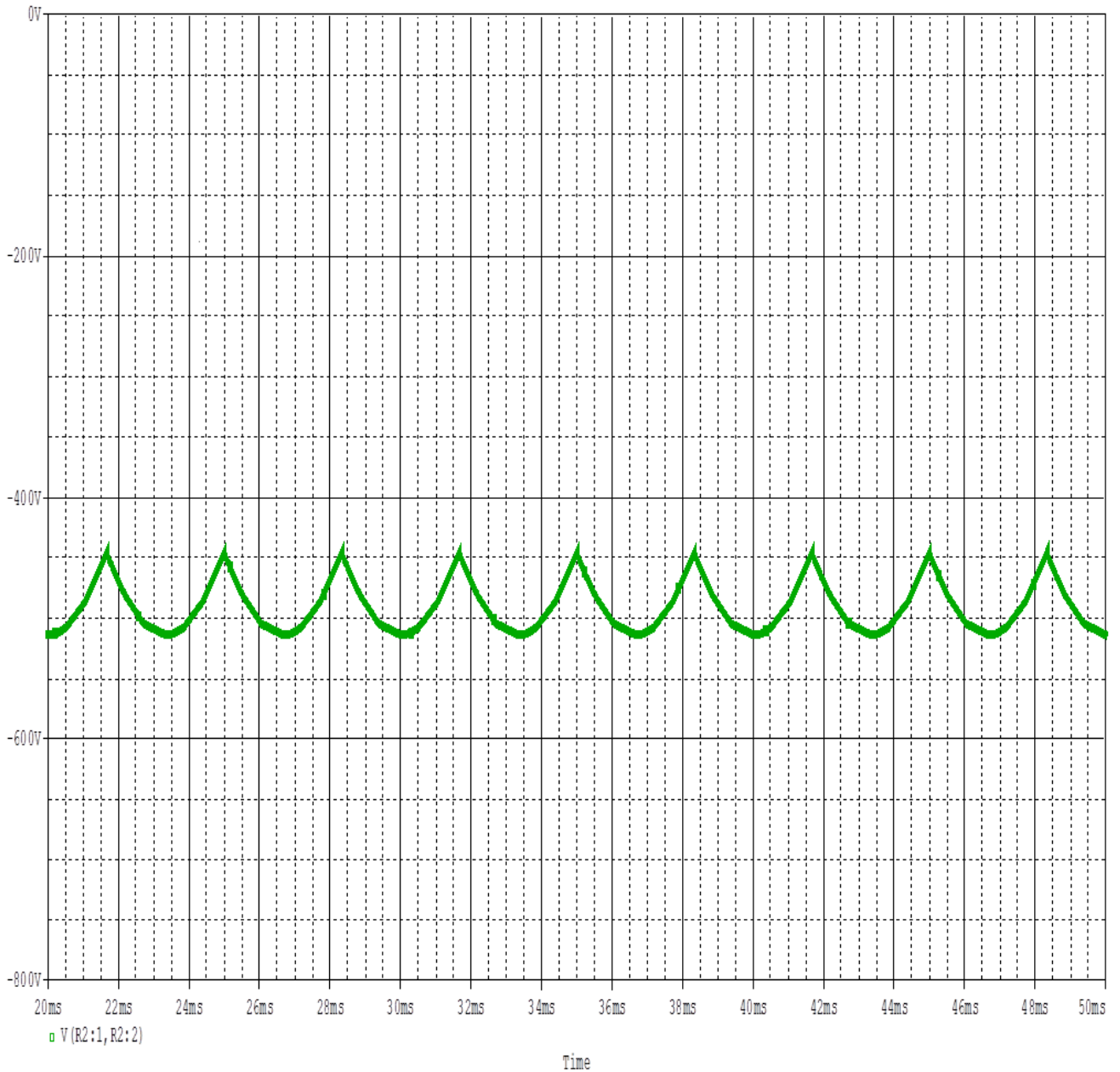

Fig: 3.2.13 Output wave shape, $\alpha = 180^\circ$

In Fig 3.2.1 we can see that the firing angle (α) is 180° . On that time, the average voltage will be highest position in negative side. In this figure the average voltage is -480V

3.4 Practical 12 pulse circuit setup using Switches (Schematics)

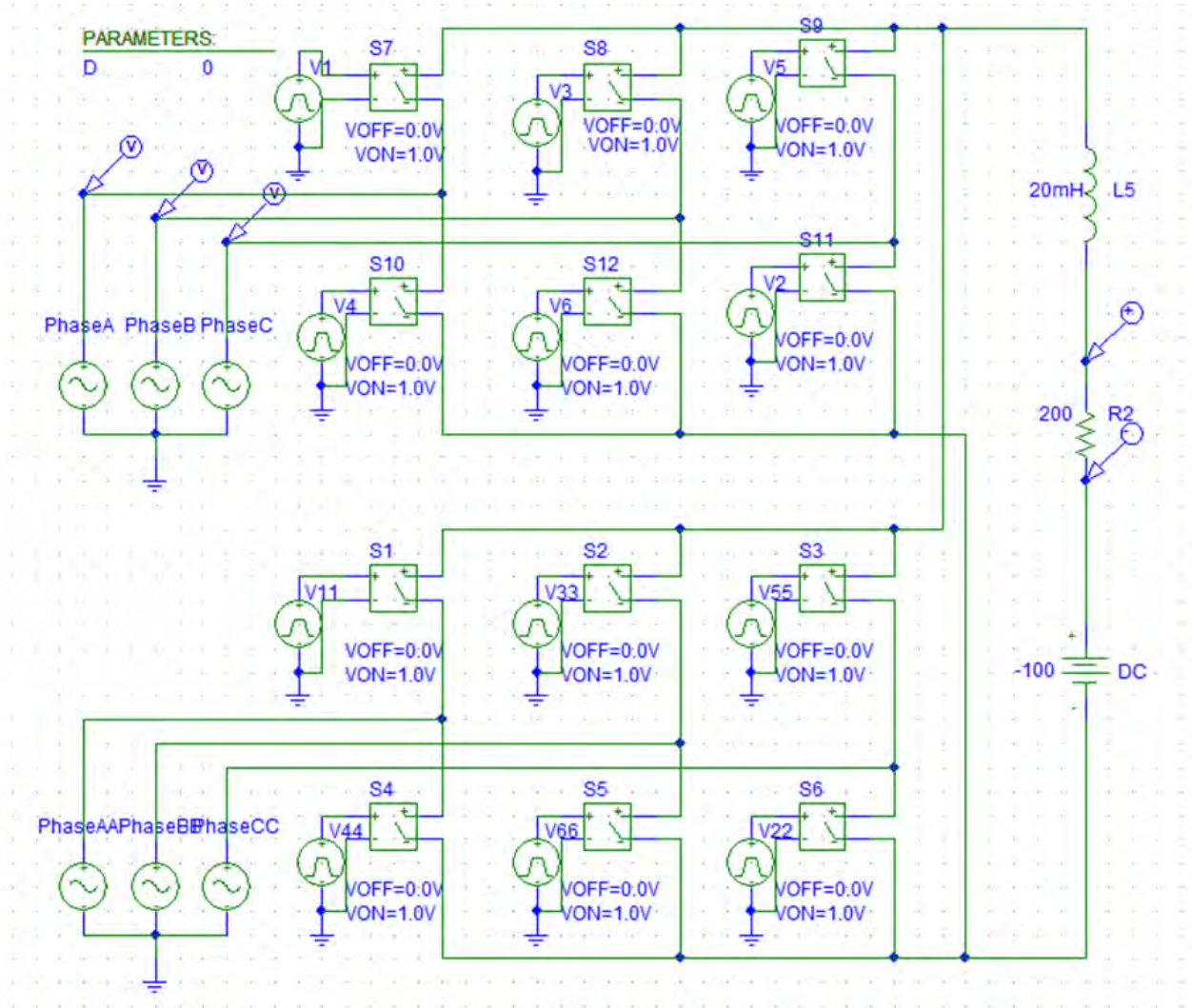

Fig: 3.3 12 pulse rectifier using Switches

Configurations:

Source Voltage:

Amplitude = 300V, Frequency = 50Hz

PhaseA, PhaseB, PhaseC is leading PhaseAA, PhaseBB, PhaseCC by 30° accordingly.

Pulse Voltage:

For all the pulses, common values are

V1=0V, V2 = 1V, Rise Time = 100ns, Fall Time = 100ns, Time Period = 20ms, Pulse

Width = 6.67ms

Time Delay

$$V1 = \{(D+30)/50/360\}$$

$$V2 = \{(D+90)/50/360\}$$

$$V3 = \{(D+150)/50/360\}$$

$$V4 = \{(D+210)/50/360\}$$

$$V5 = \{(D+270)/50/360\}$$

$$V6 = \{(D+330)/50/360\}$$

$$V11 = \{(D+30)/50/360\}$$

$$V22 = \{(D+90)/50/360\}$$

$$V33 = \{(D+150)/50/360\}$$

$$V44 = \{(D+210)/50/360\}$$

$$V55 = \{(D+270)/50/360\}$$

$$V66 = \{(D+330)/50/360\}$$

Transient Setup:

Print Step = 0.2ms, Final Time = 50ms, No Print Delay = 20ms

Parametric Sweep:

Start Value = 0, End Value = 180, Increment = 15

In 12 pulse the ripple pulse will be decreased. In Fig 3.3.1 we can see the input wave shape of 12 pulse converter.

3.5 Simulation Graphs – 12 pulse

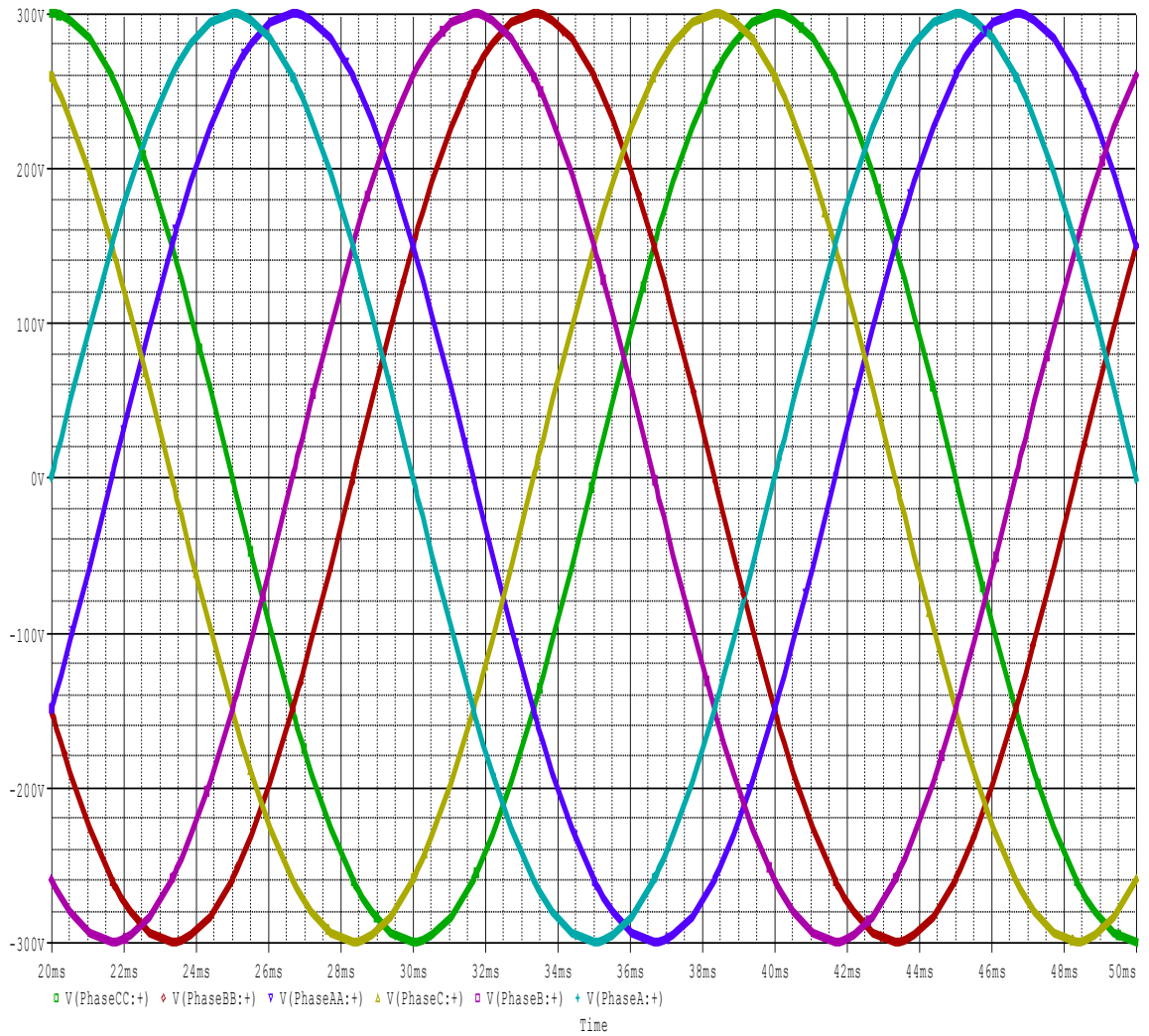

Fig3.3.1 Input wave shape

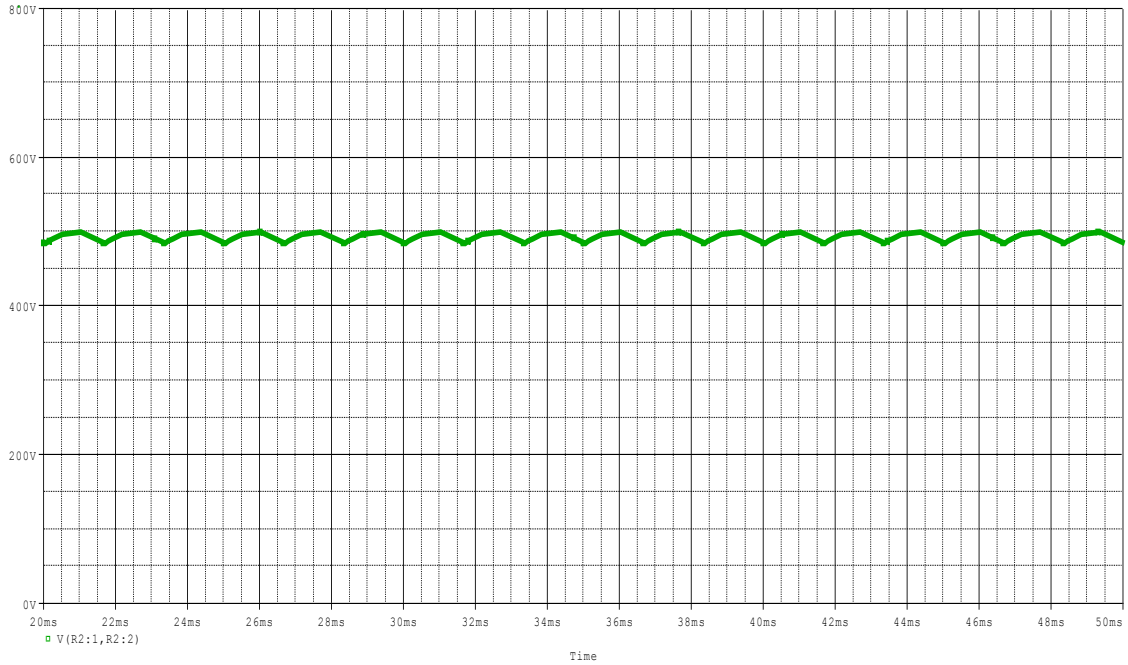

Fig: 3.3.2 Output wave shape, $\alpha = 0^\circ$

In Fig 3.3.2 we can see that the firing angle (α) is 0. On that time, the average voltage will be highest in position. In this figure the average voltage is 490V.

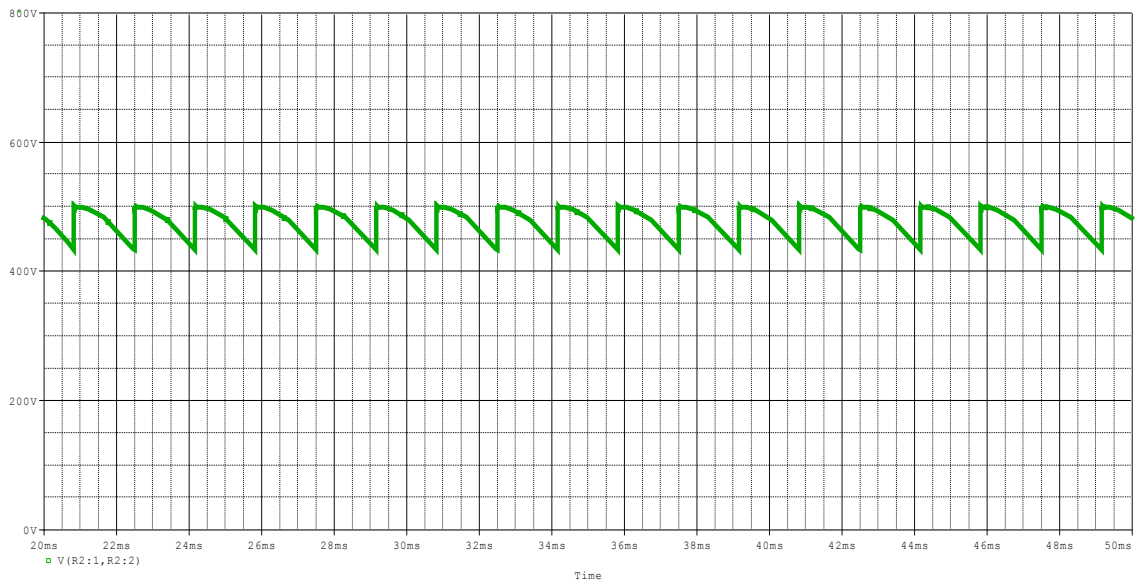

Fig: 3.3.3 Output wave shape, $\alpha = 15^\circ$

In Fig 3.2.2 we can see when the firing angle (α) is 15° . The average voltage will be lower than the average voltage of $\alpha = 0^\circ$. In this figure the average voltage is approximately 470V.

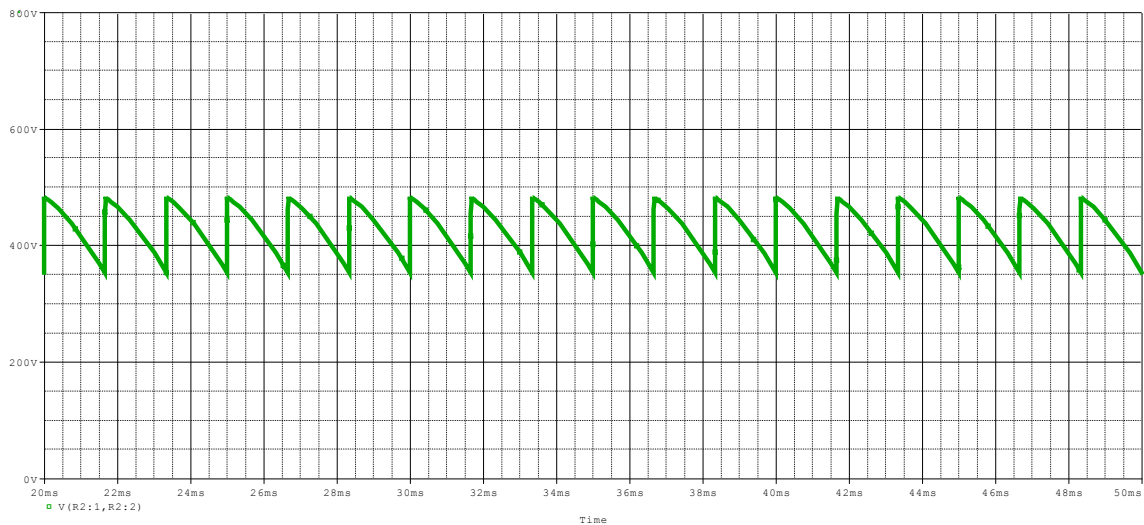

Fig: 3.3.4 Output wave shape, $\alpha = 30^\circ$

In Fig 3.3.4 we can see when the firing angle (α) is 30° . The average voltage will be lower than the average voltage of $\alpha = 15^\circ$. In this figure the average voltage is approximately 390V.

On the other hand from Fig 3.3.5 we can see when the firing angle (α) is 45° . The average voltage will be lower than the average voltage of $\alpha = 30^\circ$. In this figure the average voltage is approximately 340V.

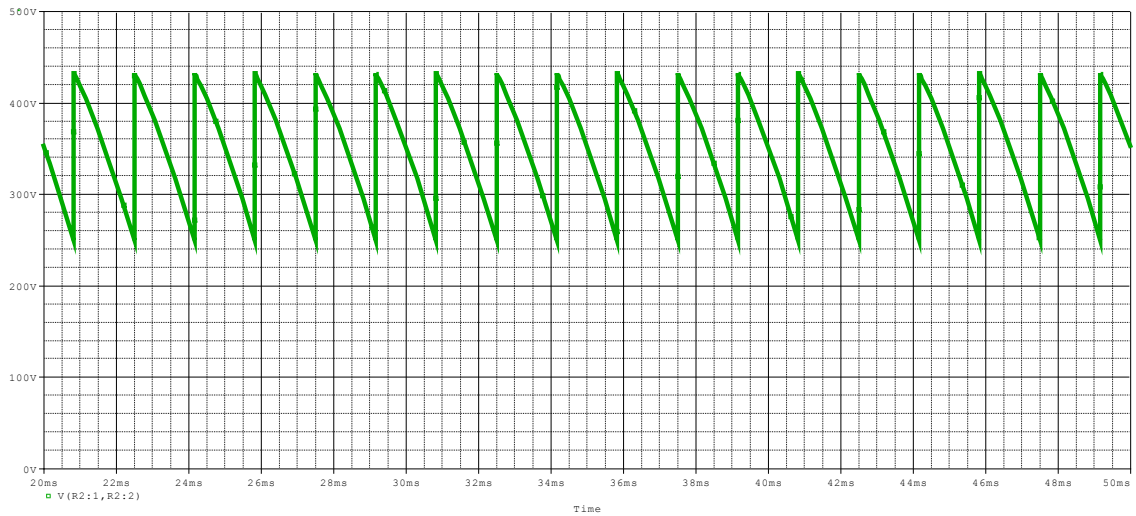

Fig: 3.3.5 Output wave shape, $\alpha = 45^\circ$

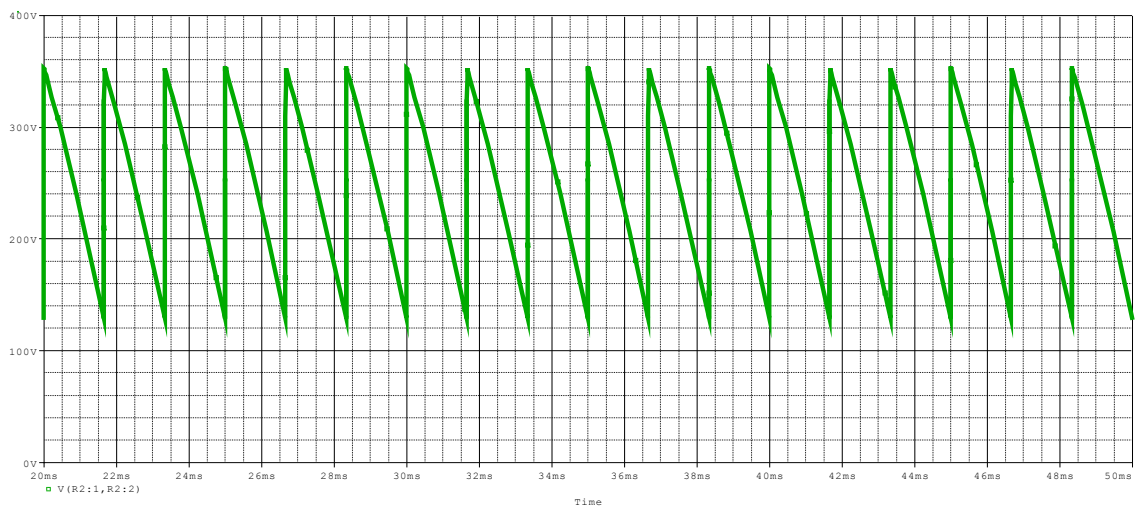

Fig: 3.3.6 Output wave shape, $\alpha = 60^\circ$

In Fig 3.3.6 we can see when the firing angle (α) is 60° . The average voltage will be lower than the average voltage of $\alpha = 45^\circ$. In this figure the average voltage is approximately 240V.

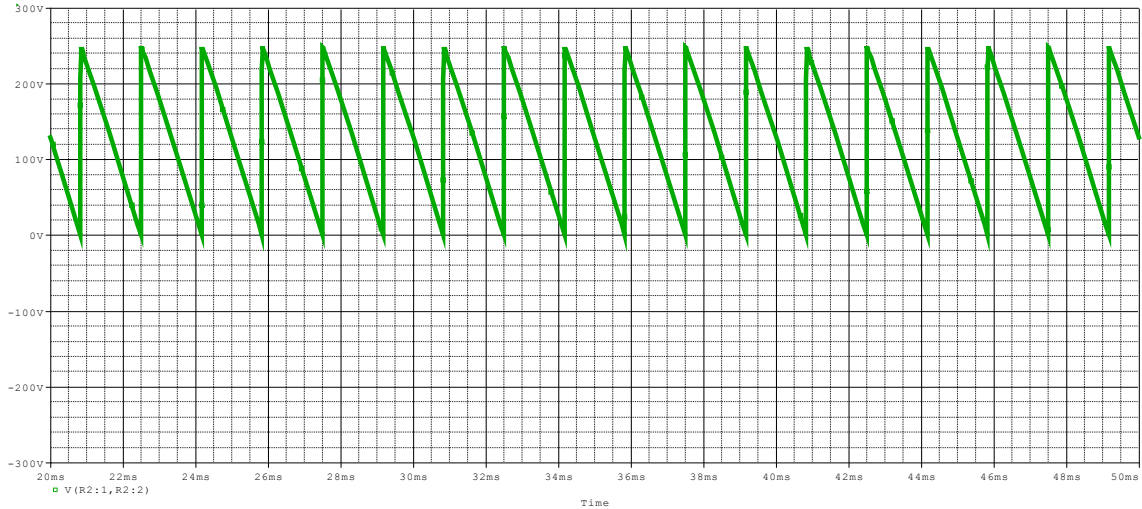

Fig: 3.3.7 Output wave shape, $\alpha = 75^\circ$

In Fig 3.3.7 we can see when the firing angle (α) is 75° . The average voltage will be lower than the average voltage of $\alpha = 60^\circ$. In this figure the average voltage is approximately 115V

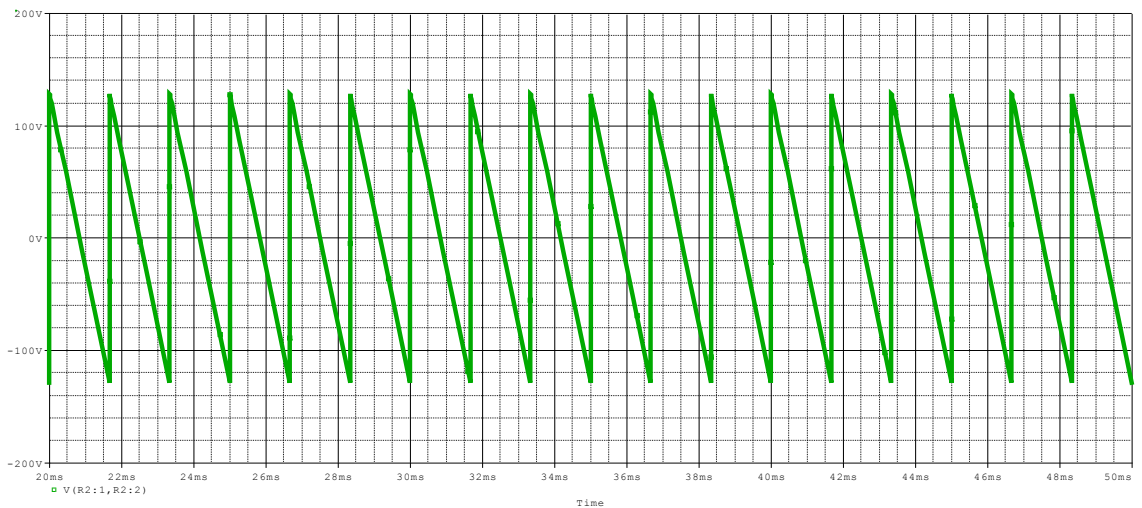

Fig: 3.3.8 Output wave shape, $\alpha = 90^\circ$

In Fig 3.3.8 when the firing angle (α) is 90° . There will be no average voltage. After this the average voltage will be negative.

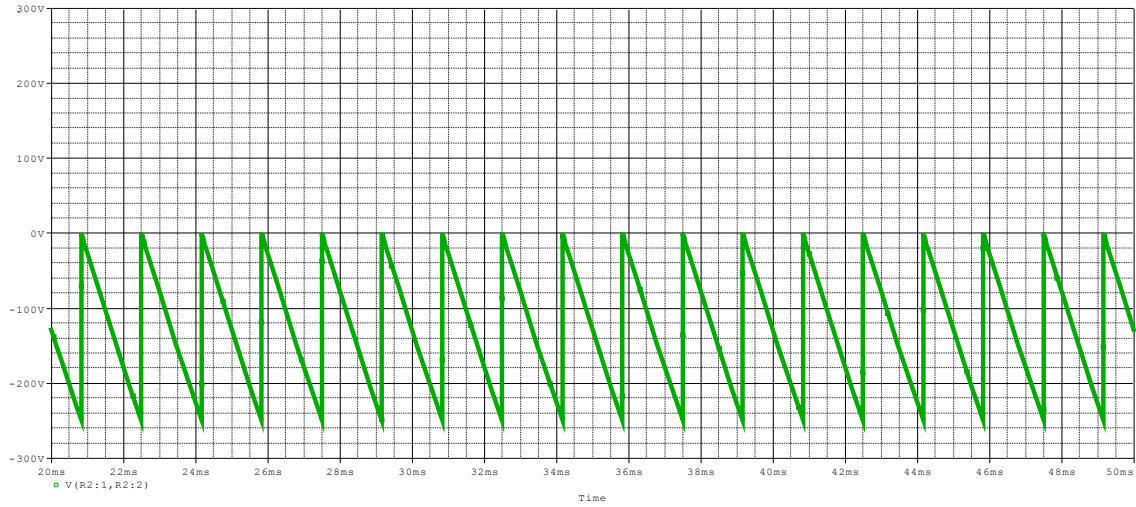

Fig: 3.3.9 Output wave shape, $\alpha = 105^\circ$

From the simulation output wave shape in Fig 3.3.9 we can see when the firing angle (α) is 105° . The average voltage will be negative. In this figure the average voltage is approximately -130V.

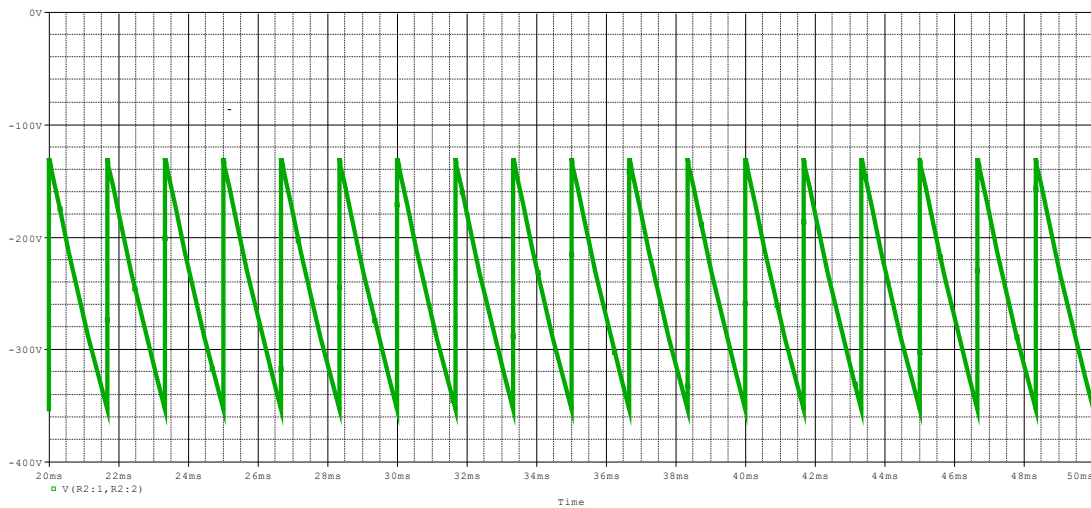

Fig: 3.3.10 Output wave shape, $\alpha = 120^\circ$

In Fig 3.3.10 firing angle (α) is 120° . The average voltage will be negative and the average voltage is approximately -240

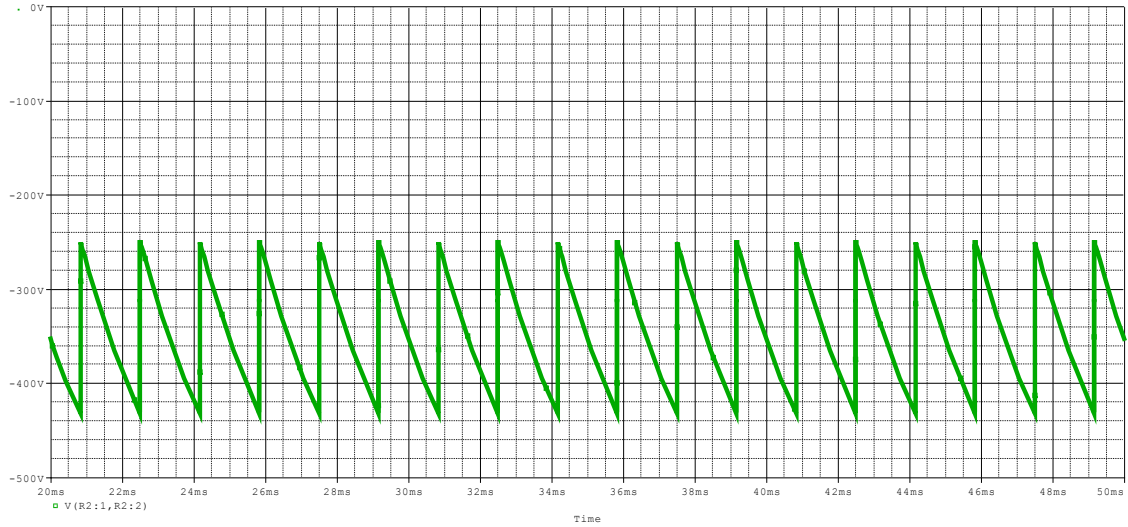

Fig: 3.3.11 Output wave shape, $\alpha = 135^\circ$

In Fig 3.3.11 we can see when the firing angle (α) is 135° . The average voltage will be lower than the average voltage of $\alpha = 120^\circ$. In this figure the average voltage is approximately -340V

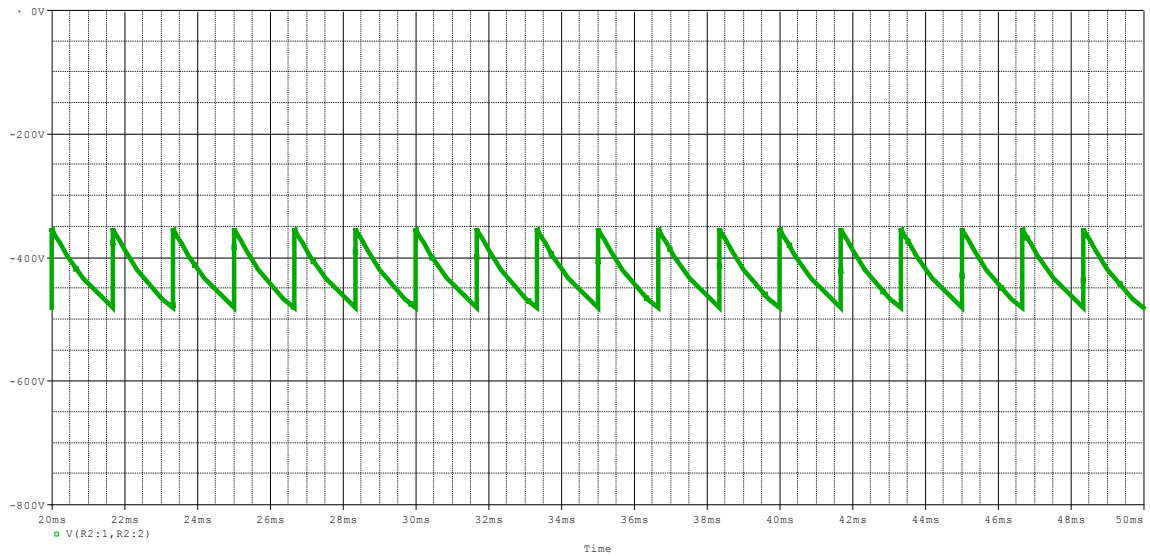

Fig: 3.3.12 Output wave shape, $\alpha = 150^\circ$

In Fig 3.3.12 we the firing angle (α) is 150° . The average voltage will be lower than the average voltage of $\alpha = 135^\circ$. In this figure the average voltage is approximately -390V

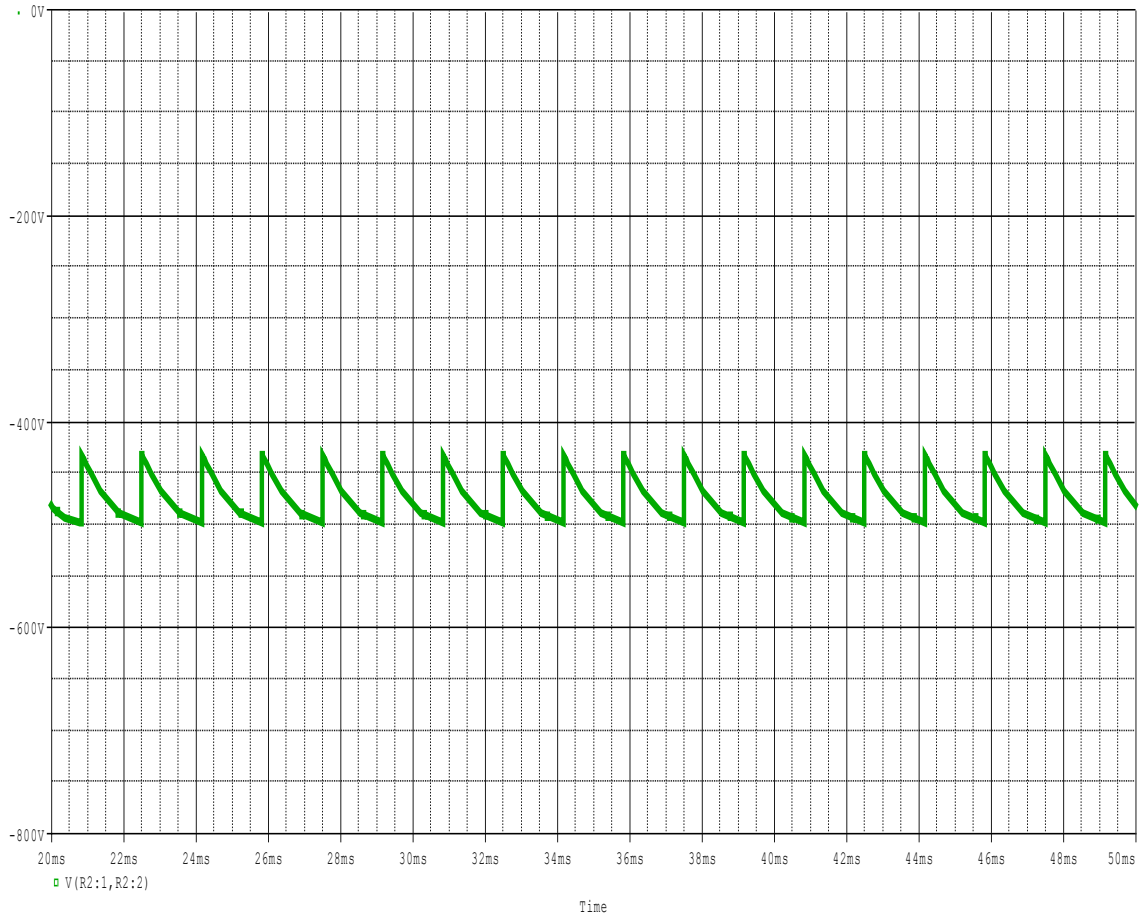

Fig: 3.3.13 Output wave shape, $\alpha = 165^\circ$

In Fig 3.3.13 we can see when the firing angle (α) is 165° . The average voltage will be lower than the average voltage of $\alpha = 150^\circ$. In this figure the average voltage is approximately -470V.

On the other hand in Fig 3.3.14 we can see that the firing angle (α) is 180° . On that time, the average voltage will be highest position in negative side. In this figure the average voltage is -480V

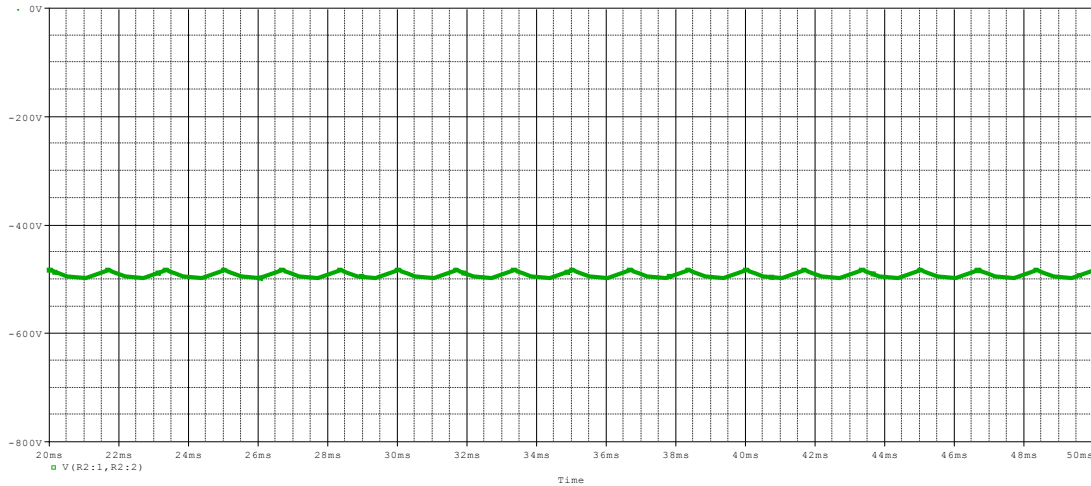

Fig: 3.3.14 Output wave shape, $\alpha = 180^\circ$

In conclusion, in this chapter, we have shown that we can make a 12 pulse converter. First of all, we simulated a circuit of a 6 pulse converter. Then we configured a 12 pulse converter and showed its results graphically.

Chapter 4

4.1 Conclusion:

In epilog we can state that we have discussed about HVDC circuits, its advantages and disadvantages and we simulate 6 pulse and 12 pulse controlled AC-DC converter by switching firing angle (α) where as output we get high voltage DC supply. In simulating, getting negative voltage by switching firing angle and solving the convergence problem we get controlled DC output. We have described about controlled rectifier (SCR) and its BJT equivalent circuit and I-V characteristics for making less complicated. We have done simulation in PSPICE for showing the output wave shave graph and experimental results.

4.2 Future Work:

In our thesis, we constructed a circuit of a 6 pole converter and simulated it. We also simulated a 12 pulse converter cum inverter circuit. Well, it does not end here. There are lots future scopes or issues where extensive research may take place. Cables are one of the most important cogs in a transmission system. The cable material for HVDC transmission system is one of the fields where research can be done. Converters efficiency, control of power conversion, improved application of thyristors, communication and control systems, protection and safety installations are also on the line. With the increased number of applications, discussions are also underway to create DC grids and smart grids, for increased flexibility and reliability.

Reference

- [1]. Sharma, S. C. and Rai, K. A. (2016, May). DC Vs AC – War of Currents For Future Power Systems: A HVDC Technology Overview. *International Journal of Scientific & Technology Research*, 5(5).
- [2]. Woodford, A. (1998, March 18). HVDC Transmission. Manitoba HVDC Research Centre.
- [3]. Wang, H. and Redfern, A. M. The advantages and disadvantages of using HVDC to interconnect AC networks. University of Bath.
- [4]. Edvard (2014, January 10). 8 main disadvantages of HVDC transmission. Retrieved from, <http://electrical-engineering-portal.com>
- [5]. Hart, D. W. (2010, January 22). *Power Electronics*. New York, NY: McGraw-Hill.
- [6]. Mohan, N., Undeland, T. M. and Robbins, W. P (1989). *Power Electronics: Converters, Applications, and Design*. Toronto, Canada: John Wiley & Sons, Inc.
- [7]. [Online]. Available: <http://circuitglobe.com>
- [8]. [Online]. Available: <http://brighthubengineering.com>
- [9]. [Online]. Available: <http://allaboutcircuits.com>
- [10]. [Online]. Available: <http://electronicspot.com>