

Thesis Title:
State Space Modeling of a BUCK Converter and Designing a Controller



A THESIS REPORT

**SUBMITTED TO THE DEPARTMENT OF ELECTRICAL
ENGINEERING
AND
THE COMMITTEE FOR UNDERGRADUATE STUDIES**

**OF
BRAC UNIVERSITY**

**IN PARTIAL FULFILLMENT OF THE REQUIREMENTS FOR
THE DEGREE**

OF

**BACHELOR OF SCIENCE (B.sc) in ELECTRICAL &
ELECTRONICS ENGINEERING (EEE)**

BY

**SHAIK RAJU AHMED – 12221033
NUSRAT JAHAN NOOR – 13221051
SUMAIYA MOSTAFA - 13221044**

SUPERVISED BY

**MRS. AMINA HASAN ABEDIN
ASSISTANT PROFESSOR
DEPARTMENT OF ELECTRICAL & ELECTRONICS
ENGINEERING (EEE)
BRAC UNIVERSITY, DHAKA**

Table of Contents

DECLARATION.....	06
ACKNOWLEDGEMENT.....	07
ABBREVIATION.....	08
ABSTRACT.....	09

CHAPTER -01

1.1 Electronic converter.....	10
1.2 DC –DC converter.....	11
1.3 Comparison between linear and switching regulator.....	12

CHAPTER02

2.1:Some applications of buck converter.....	14
2.2:Buck converters.....	14
2.3:Voltage Source.....	15
2.4:Power converters.....	16
2.5:Capacitor.....	16
2.6:Inductor.....	17
2.7: The load.....	17
2.8: The Freewheeling diode.....	17
2.9:Operation of buck converter.....	18
2.10:Analysis of a typical buck converter.....	20
2.11:CCM waveforms.....	24

Chapter 03:

3.1:Design parameters of Buck converter	25
3.2:Calculation of unknown parameters.....	25

3.3:PSPICE Simulations.....26

CHAPTER 04

4.1:The control stage.....30
4.2:Small signal modeling.....30
4.3:PWM controller and PWM.....31
4.4:Comparator and voltage to PWM Converter.....32
4.5:Feedback Control System.....33
4.6:State Space Approach.....35
4.7:Model Simplification.....41
4.8:The Pulse Width Modulator.....43
4.9:Bode Plot of the Filter Circuit.....45
4.10:Calculation of Transfer Function.....46
4.11:Transfer Function of the Compensator.....47
4.12:Bode Plot of the Compensator.....47
4.13:Simulation of the Feedback with Filter Network.....48

CHAPTER 05

5.1:Future Scopes.....49
5.2:Conclusions.....50
5.3:References.....51

List of Figures

CHAPTER02

2.1: Typical Buck Converter.....	15
2.2: Typical Buck Converter with MOSFET Switch.....	19
2.3: On State(Switch is Closed).....	19
2.4: Off State(Switch is Open).....	19
2.5: Buck Converter Analysis.....	21
2.6: CCM(Continuous Conduction Mode)Waveform.....	24

CHAPTER03

3.1: PSPICE Simulation of Buck Converter.....	26
3.2: Output voltage waveform.....	26
3.3: Inductor current waveform.....	27
3.4: Diode Voltage Waveform.....	27
3.5: Inductor Voltage Waveform.....	28
3.6: Output Current Waveform.....	28

CHAPTER04

4.1: Voltage Reference Comparator.....	31
4.2: PWM(Pulse Width Modulator)Comparator Signal.....	33
4.3: Feedback Control System.....	34
4.4: Linearized Feedback Control System.....	34
4.5: Buck Converter circuit.....	38
4.6: (a)Switch On and (b) Switch Off Mode	38
4.7: Pulse Width Modulator.....	43

5 | State space modeling of a buck converter and designing a controller

4.8:Bode Plot of Buck Converter Transfer Function.....	45
4.9:Compensator Bode Plot.....	47
4.10:Output Voltage with variable Load Correction.....	48

DECLARATION

We hereby declare that research work titled “*State Space Modeling of a BUCK Converter and Designing a Controller*” is our own work. The work has not been presented elsewhere for assessment. Where material has been used from other sources it has been properly acknowledged/referred.

Signature of
Supervisor

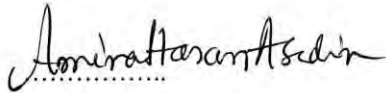

Mrs. Amina Hasan Abedin

Signature of
Authors

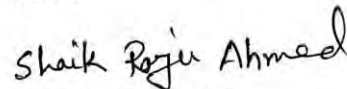
22-08-2017

Shaik Raju Ahmed

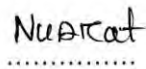

Nusrat Jahan Noor

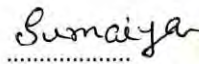

Sumaiya Mostafa

ACKNOWLEDGEMENTS

Firstly, We would like to thank Mrs. Amina Hasan Abedin, Assistant Professor, Dept. of Electrical and Electronic Engineering (EEE), BRAC University; for her supportive guidance and feedbacks for completion of the thesis. Secondly, our gratitude is towards BRAC University authority and the department of EEE for allowing us to do this thesis as a partial requirement to fulfill our undergraduate degree. We would also like to thank every other individual without whose contribution; the project would not be a success.

ABBREVIATIONS:

BJT	Bipolar Junction Transistor
CCM	Continuous Conduction Mode
CMC	Current Mode Control
CMOS	Complementary MOS
DC	Direct Current
DCM	Discontinuous Conduction Mode
DCR	Direct Current Resistance
ESL	Equivalent Series Inductance
ESR	Equivalent Series Resistance
MOSFET	Metal Oxide Semiconductor Field Effect Transistor
NFET	Negative Channel Field Effect Transistor
PWM	Pulse Width Modulation
SMPS	Switch Mode Power Supplies
SRBC	Synchronous Rectifier Buck Converter
VMC	Voltage Mode Control

Thesis Abstract:

Modeling is the mathematical representation of a circuit. For mathematical representation knowledge of state space modeling or state space representation is required. For state space representation, it is necessary to define the state variable of a circuit. State variable is the kind of variable that can be represented in the form of integration. Mathematical representation of the actual circuit which represents the output with respect to the input in non-linear is known as large signal representation. It is not possible to control the circuit when it is in large signal model/representation. For controlling it is necessary to bring the circuit in the specific operating range at a certain steady state point. Around this point range the circuit is called linearized. Applying any of the specific control technique on the linearized circuit we will design the controller. Controller will sense the output and determine the deviation where from it will be determined how much D (Duty Cycle) will be needed to add or subtract with the steady state D in order to operate the converter properly.

Chapter 1:

1.1: Electronic Converter:

Electronic converters are devices that can convert voltages from one level to another level. The goal of electronic converters is to process and control the flow of electric energy by controlling the voltages and currents in a form that is optimally suited for user loads. In the circuit set up converters use switches, diode, energy storage elements like inductors and capacitors.

The production of electrical power from different power stations gives us an alternating current from the alternator. On the application side, the end user uses the power generated to run various types of electrical devices. These devices in turn use different types of voltage (direct or alternating) with different magnitude levels. Some of the devices need high magnitude voltage level and some of the devices need low magnitude level voltage.

For these reason, there exists a necessity to convert these voltages as per our requirement. This is the area where converters come into application. A question may be raised that, why not reduce the magnitude levels using a potential divider, if at all the voltage or power level is the only concern for the appliances. But, there lies an need to reduce the lossy component in the circuit (to improve efficiency), make it compact, incorporate changes in parameters if required (like frequency adjustments), as well as the most important reason to make it economical.

Considering all the above factors, the necessity of a converter is well defined. Converters are classified into 4 types depending on the type and magnitude level of voltages are concerned:

1. AC-AC converters
2. AC-DC converters
3. DC-DC converters
4. DC-AC converters

This thesis deals with the DC-DC BUCK converters, so first of all we need to know about the DC-DC converters.

1.2:

DC – DC Converter:

A DC-to-DC converter is an electronic circuit power class converter which converts a source of direct current (DC) from one voltage level to another. If the voltage magnitude level at the output is greater than the input, then the converter is called a boost converter, and if the voltage magnitude level at the output is lesser than the input, then the converter is called a buck converter. If both the converter operations (buck and boost) are resulted from a single converter with the control of the mode of operation, whether buck or boost is monitored using the parameter “duty cycle”, such converters are Buck-Boost converters. Cuk converter is a dc- dc converter that allows bidirectional voltage conversion with the output voltage of inverted polarity.

For our narrowed down topic we chose DC-DC Buck Converters. Buck converter is explained in this thesis in detail in this document. Buck converters are, as explained above, converts a source of direct current from higher voltage magnitude level to a lower voltage magnitude level.

One question may be raised, why not use a linear regulator for reducing the voltage?

The answer is linear regulators prove to be efficient over the switching regulators (such as the above converters) when the output is lightly loaded or when the output voltage desired is very close to the source voltage. Also linear regulators are cancelled of magnetic circuit involving transformers or inductors thus resulting in a relatively smaller circuit. Other than these conditions if a linear regulator is used, the BJT which is usually used for regulation, acts as a resistor, with the power loss across it numerically equal to the product of voltage drop across the transistor input and output terminals, and the current flowing through it. In order to make loss due to resistive drop almost negligible, we use switching regulators.

All of our discussion can be summarized with the following comparison Table (Table number -1) described next:

1.3: Comparison between linear and switching regulator:

	Linear	Switching
Function	Only steps down; input voltage must be greater than output.	Steps up, steps down or inverts.
Waste heat	High, if average load and/or input/output voltage difference are high.	Low, as components usually run cool for power levels below 100W
Complexity	Low, Which usually requires only the regulator and low value bypass capacitor.	Medium to High, which usually requires inductor diodes and filter caps in addition to IC; for high power circuits, external FET are needed.

13 | State space modeling of a buck converter and designing a controller

Size	Small to medium in portable designs, but may larger if heat sinking is needed.	Larger than linear at low power, but smaller at power level for which linear requires heat sinks.
Total cost	Low	Medium to high
Ripple / Noise	Low; No ripple, Low noise, better noise rejection	Medium to High; Due to ripple at switching rate.
Efficiency	Low to medium, but actual life depend on load current and battery voltage.	High, except at very low load current (μA), where switch mode quiescent, current is usually higher.

Table Number-1

So, that is why we chose to work with Switch mode buck converter for our thesis.

Chapter 2:

2.1:

Some Applications of Buck Converter:

As the voltage level goes down and the current level goes up we can use of buck converters where high current and low voltage is needed. Some usage are:

1. It converts the computers main supply down to lower voltage needed by USB, CPU, DRAM etc.
2. USB ON THE GO allows the keyboard mouse and other peripherals to connect to the phone. Peripheral devices draws power from the buck converter .Synchronous buck converter is bi-directional. Buck converters are used to charge the lithium battery in the phone .When other devices are connected the converter run in the backward direction and work as boost converter to generate voltage from the battery.
3. Quad-copters often are powered from a multi-cell lithium battery pack, typical pack configurations are 2-6 cells in series. These battery packs produce a voltage in the range of 6V-25V. A buck converter drops the battery voltage down to 5V or 3.3V for the flight controller (the brain of the quad-copter) to use. Moreover quad-copters use brushless motors to fly because of their high efficiency and lightweight. Three half-bridges are used to drive the inductive coils of a brushless motor. They use synchronous buck converters without filter capacitors.

2.2:

Buck Converters:

Buck converters are used only if the voltage levels to be reduced is less than the order of 10. If the scaling is more than 10, then we need to use an isolated type, fly-back converters. Considering the non isolated buck converters, we will do the detailed study of a buck converter first.

The figure 2.1 shows the typical buck converter diagram. As shown, the converter consists of the following components:

1. Direct Voltage Source : $V_g = V_{in}$
2. Power Converter (represented as Switch) : S_w
3. Filter Inductor : L_f
4. Filter Capacitor : C_f
5. Load Resistor: R_L
6. Freewheeling Diode : D_f

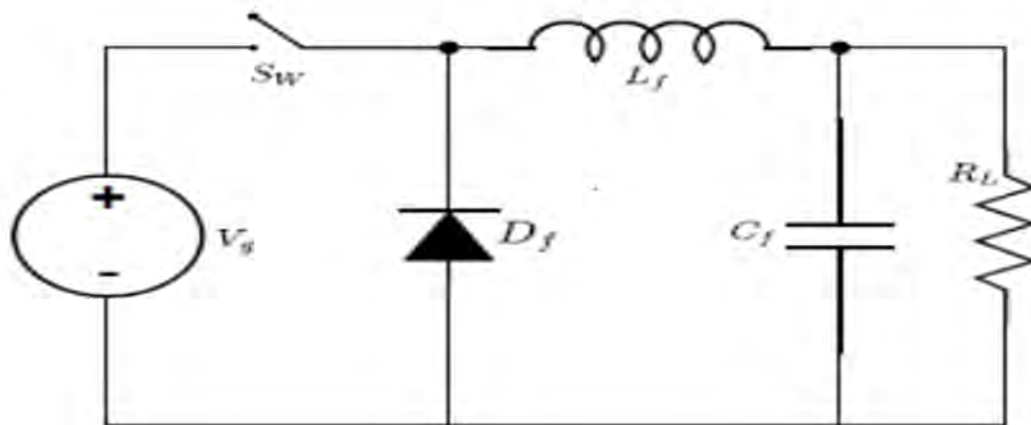

Figure 2.1: Typical Buck Converter

2.3: Voltage Source

Voltage Source is of course a basic requirement for the converter circuit. In a typical buck converter as shown in figure no-2.1, we can see that the source voltage is direct voltage. The characteristics of an ideal direct voltage source is to provide a constant voltage independent of the current drawn from it by the load.

Practically, the voltage sources fall short of ideal and the terminal voltage drops with the increase in the output current drawn by the load. For simplicity, we have considered the source as ideal in our analysis.

2.4:

Power Converter

A Power Converter is referred to a power electronic circuit that converts voltage and current from one form to another. An operative unit for electronic power conversion, comprising one or more electronic valve devices, transformers and filters if necessary and auxiliaries if any is called an electronic Power Converter. So, the term converter refers to a power electronic circuit that takes in electric power in one form and gives out electric power in another form. A converter is a combination of one or more solid state electronic switching devices with filtering elements like inductors and capacitors (cancellation of resistors to reduce power loss and hence increase efficiency) connected in different topologies, which depends on the application.

The switching element is an important part of a converter and is clearly shown in figure no-2.1. The control for the switch is provided externally with the help of triggering circuits or control circuits or firing circuits. This converter block is termed as a power circuit or power electronic circuit. This power electronic circuit along with the control circuit or firing circuit, forms the Power Processor.

The control circuit operates with the feedback signal from the output, and sometimes with an addition of feed-forward signal from the input and a reference signal.

2.5:

Capacitor

The Filter Capacitor is required to smoothen out the voltage waveform. It filters the rippled waveform and provides a constant output voltage across the load.

2.6:

Inductor

The filter inductor is required to smoothen out the current ripple as well as to reduce the high di/dt caused at the instant of switching. This will not only improves the regulation of the output, but also protects the switch to be stressed due to switching flow in current during switching. It is to be noted that the switching frequencies will be in the order of kilohertz and this high causes the switch to drive away a large amount of power.

2.7:

The load

Load is any appliance which we connect across the output terminals of the converter. This can be a simple Resistive load as shown in above figure no-2.1 (Typical Buck Converter), or can be still more complex with active and passive elements. Since the requirement given by the resistive output load, we have considered here the resistive load.

2.8:

The Freewheeling Diode

We will analyze the above circuit shown in the above figure no-2.1 (Typical Buck Converter) without the freewheeling diode and the capacitor (for simplicity). First we will close the switch S_w at time t_x , a current is established in the circuit through the load and then if the switch is opened at the instant t_y ,

the inductor L_f is charged and as soon as the switch is opened, the inductor looks for a path to discharge its stored energy. Otherwise, this leads to a sparking across the switch terminals leading to the malfunction or destruction of the switch itself due to the high amount of heat dissipated across the switch.

In order to provide a path for the inductor to drive away the current, we require a freewheeling diode, which provides a path for the inductor current to flow through the load as soon as the switch is opened.

2.9: **Operation of BUCK Converter:**

The name “Buck Converter” presumably evolves from the fact that the input voltage is bucked/chopped or attenuated, in amplitude and a lower amplitude voltage appears at the output. A buck converter, or step-down voltage regulator, provides non-isolated, switch-mode dc-dc conversion with the advantages of simplicity and low cost.

The operation of the buck converter is simple, with an inductor and two switches (usually a MOSFET and a diode) that control the inductor. It alternates between connecting the inductor to source voltage to store energy in the inductor and discharging the inductor into the load.

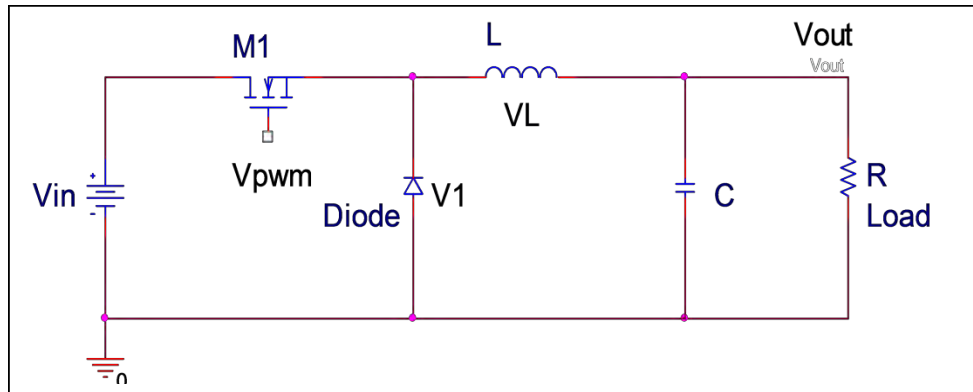

Figure No-2.2: Typical Buck Converter with a MOSFET Switch

Figure (typical buck converter) shows the circuit diagram of a Buck-converter. The MOSFET $M1$ operates as the switch, which is turned on and off by a pulse width modulated (PWM) control voltage V_{PWM} . The ratio of the on time (t_{on}) when the switch is closed to the entire switching period (T_{sw}) is defined as the duty cycle

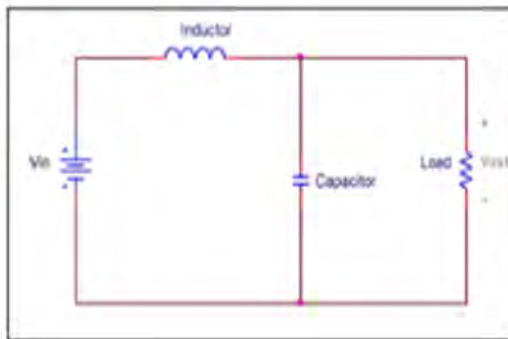

Figure No-2.3: On State

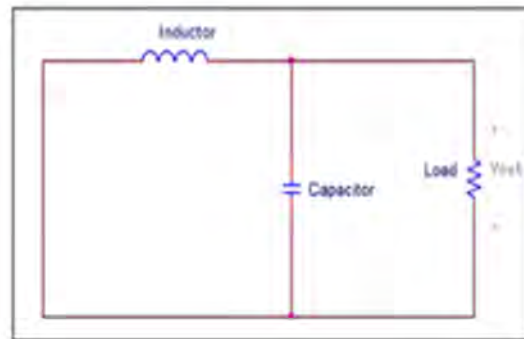

Figure No.-2.4: Off State

The equivalent circuit in the above Figure no-2.3 is valid when the switch is closed. The diode is reverse biased, and the input voltage supplies energy to the inductor, capacitor and the load. When the switch is open as shown in Figure no-2.4 the diode conducts and the capacitor supplies energy to the load, and the inductor current flows through the capacitor and the diode. The output voltage is controlled by varying the duty cycle. In steady state, the ratio of output voltage to the input voltage is “D”, given by V_{out}/V_{in} .

2.10:

Analysis of a Typical Buck Converter

Assuming that the current flow in the inductor is continuous, we are now analysing the buck converter in Continuous Conduction Mode. From the basic principle we know that,

$$e_L = L_f \frac{di}{dt} \dots\dots\dots (2.1)$$

Assuming the inductor current rises linearly in the inductor, we can say that
 $V_{in} - V_0 = L_f (I_2 - I_1) / t_2 \dots\dots\dots (2.2)$

Where v_0 is the output constant voltage across the load resistor.

$$t_1 = L_f \frac{\Delta I}{(V_{in} - V_0)} \dots\dots\dots (2.3)$$

Where, $\Delta I = I_2 - I_1$

This is for the period of which the switch is on. This time period t_1 is called on time period. This is denoted by

$$t_{on} = D T_s$$

Here, $D = K =$ duty cycle.

For time period $(1-D)T_s = t_{off}$. when switch is off the input voltage is zero.

so, $0 - V_0 = L_f (I_2 - I_1) / t_2 \dots\dots\dots (2.4)$

$$V_0 = L_f (\Delta I / t_2) \dots\dots\dots (2.5)$$

$$t_2 = L_f (\Delta I / V_0) \dots\dots\dots (2.6)$$

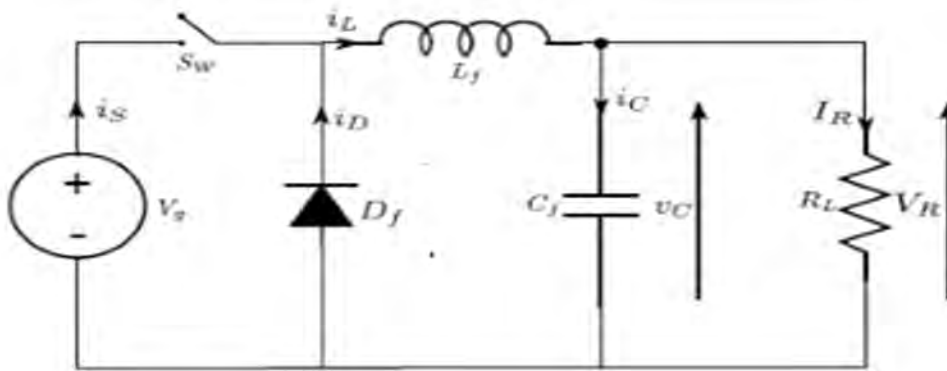

Figure No-2.5: Buck Converter Analysis

From the equation 2.3 and 2.6 we get,

$$\begin{aligned} \Delta I &= (V_{in} - V_o) t_1 / L_f \\ &= V_o t_2 / L_f \dots \dots \dots (2.7) \end{aligned}$$

Simplifying the equation 2.7 we get an expression for average voltage V_o ,

$$V_o = D V_{in} \dots \dots \dots (2.8)$$

Where, $D = t_{ON} / T_s$ is the duty cycle of the switch.

Neglecting the losses in the switch we can write that input power is equal to output power.

$$V_{in} I_{in} = V_o I_o \dots \dots \dots (2.9)$$

where,

$I_g = I_{in}$ is the source current

$I_0 = I_{out}$ is the average output current

From the above equation 2.9, we can write,

$$I_{in} = D I_o \dots \dots \dots (2.10)$$

To find the switching period, from the equation 2.3 and 2.6,

$$\begin{aligned} T_s &= 1/f_s = t_1 + t_2 \\ &= L_f \Delta I / (V_{in} - V_o) + (L_f \Delta I / V_o) \dots \dots \dots (2.11) \end{aligned}$$

$$T_s = L_f V_{in} \Delta I / V_o (V_{in} - V_o) \dots \dots \dots (2.12)$$

To find the peak to peak ripple current, using 2.12 we get

$$\Delta I = V_o (V_{in} - V_o) / f_s L_f V_{in} \dots \dots \dots (2.13)$$

Or,
$$\Delta I = V_{in} D (1 - D) / f_s L_f \dots \dots \dots (2.14)$$

We assume that load current is free of ripple and whatever ripple is present in the inductor current will be smoothed by the capacitor. Hence we can write,

$$i_L = i_C + i_0 \dots \dots \dots (2.15)$$

$$\Delta i_L = \Delta i_C \dots \dots \dots (2.16)$$

So that, $\Delta i_0 = 0$

Now consider the waveform of inductor current i_L and i_C given in figure 2.3 .we can see that both the waveform add up to make a steady state output current i_0 to be constant .for the upper half of the current ripple triangle we can write the equation of the area of triangle as $\frac{1}{2} (t_1/2 + t_2/2)\Delta I/2$ which is equal to $\Delta I/4$,for a period of $T_s/2$. For this period capacitor charges. The charging current of the capacitor I_C is,

$$I_C = \Delta I/4 \dots \dots \dots (2.17)$$

Now capacitor ripple voltage is,

$$v_C = \frac{1}{C_f} \int i_C dt + v_C(0^-) \dots \dots \dots (2.18)$$

$$\Delta v_C = \frac{1}{C_f} \int_{t=0}^{T_s/2} \Delta i_C + v_C(0^-) \dots \dots \dots (2.19)$$

$$\begin{aligned} \Delta v_C &= \Delta Q / C_f \\ &= (1/C_f) (\frac{1}{2}) (T_s/2)(\Delta I/2) \\ &= T_s \Delta I / 8 C_f \dots \dots \dots (2.20) \end{aligned}$$

Where we have considered the charging cycle of the capacitor with ΔQ as the charge accumulated during the period $T_s/2$ as explained above.

Now by putting the value of ΔI from equation 2.13 and 2.14 correspondingly we get,

$$\Delta v_c = V_o(V_{in} - V_o) / 8 L_f C_f f_s^2 \dots \dots \dots (2.21)$$

And

$$\Delta v_c = V_{in} D(1-K) / 8 L_f C_f f_s^2 \dots \dots \dots (2.22)$$

To find the critical value of the inductor and capacitor, the condition for continuous inductor current and capacitor voltage is,

$$I_L = \Delta I / 2 \dots\dots\dots(2.23)$$

And,

$$V_o = \Delta v_C / 2 \dots\dots\dots(2.24)$$

Substituting the value of ΔI from the equation 2.23 in equation 2.24,

$$\begin{aligned} V_{in} D(1-D) / f_s L_f &= 2I_L \\ &= 2I_o \\ &= 2DV_{in} / R_L \dots\dots\dots(2.25) \end{aligned}$$

So, $L_C = L_f \geq (1-D)R_L / 2f_s \dots\dots\dots(2.26)$

$$V_{in} D(1-D) / 8L_f C_f f_s^2 = 2V_o = 2DV_{in} \dots\dots\dots(2.27)$$

So, $C_C = C_f \geq (1-D) / 16L_f f_s^2 \dots\dots\dots(2.28)$

This complete the analysis part of the converter circuit.

2.11:

CCM waveforms:

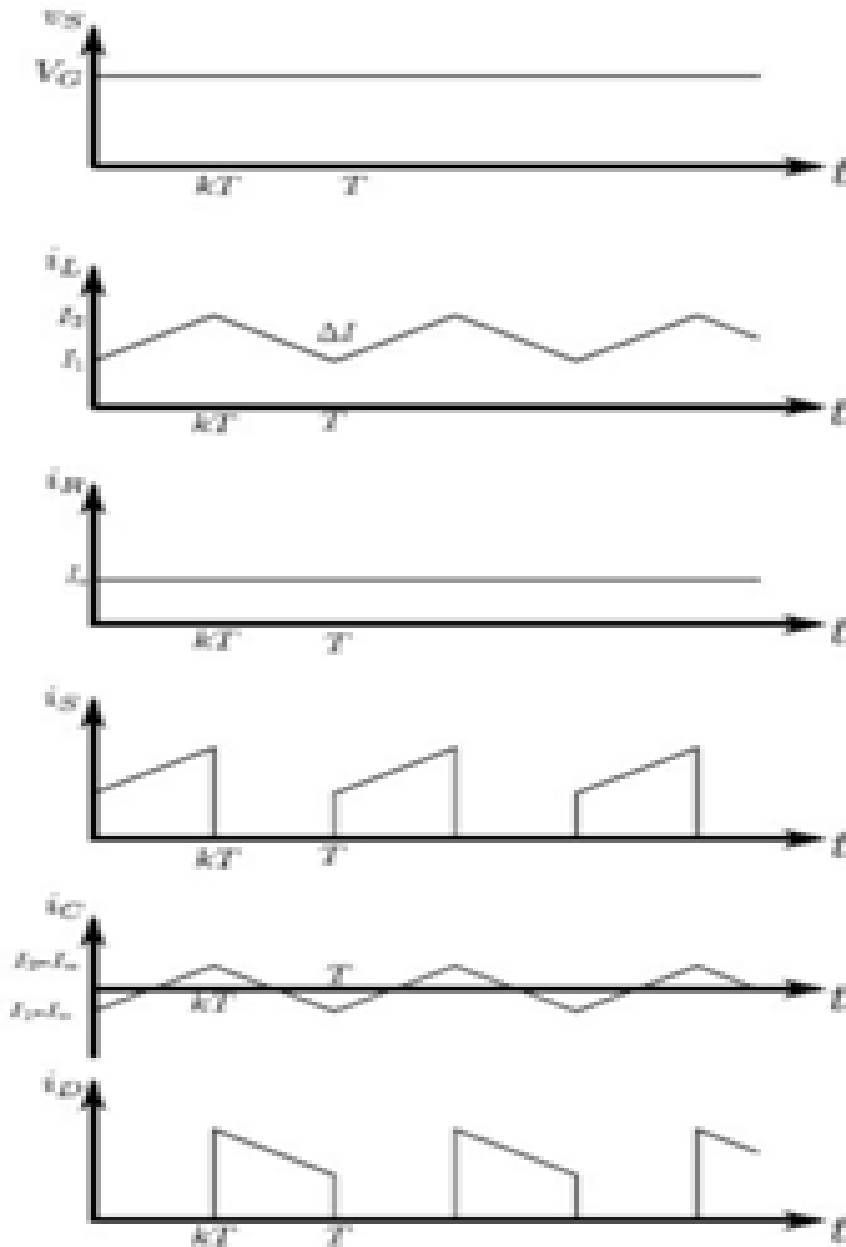

Figure No.-2.6: Continuous Conduction Mode Waveforms

Chapter 03:

3.1:

Design parameters of Buck Converter:

Given parameters of the Buck Converter:

Input voltage (V_{in})=12V

Output Voltage (V_{out})=5v

Switching frequency (F_s)=10KHz

Output current ripple =1.5 Amp

Output voltage ripple=45mV

Cross over frequency=2 KHz

Load current (I_L) =5amp

Inductance $L=194\mu\text{H}$

3.2:

Calculations of Unknown parameters:

To find the value of output resistor (R_L)

$$R_L = V_{out} / I_L = 5/5 = 1 \text{ Ohms} \quad (3.1)$$

To find the value of duty cycle ($D=K$)

$$K = D = V_{out} / V_{in} = 5/12 = 0.4167 \quad (3.2)$$

To find the Time period of switching (T_s)

$$T_s = 1/F_s = 1/10 \times 10^3 = 0.0001 \text{ s} \quad (3.3)$$

To find the ON period of the switch (t_{on})

$$t_{on} = DT_s = 0.4167 \times 0.0001 = 41.6 \mu\text{s} \quad (3.4)$$

Critical Inductance, $L_c \geq (1-D)R_L / 2F_s = (1-0.4167)1/2(10 \times 10^3)$
 $= 29.16 \mu\text{H}$

Capacitance, $C = 416 \mu\text{F}$ critical capacitance, $C_c \geq (1-D)/8L_c F_s^2$

$$= (1-0.4167)/(8 \times 29.16 \times (10 \times 1000)^2) = 2.5 \times 10^{-11} \text{ F}$$

3.3: PSPICE Simulations:

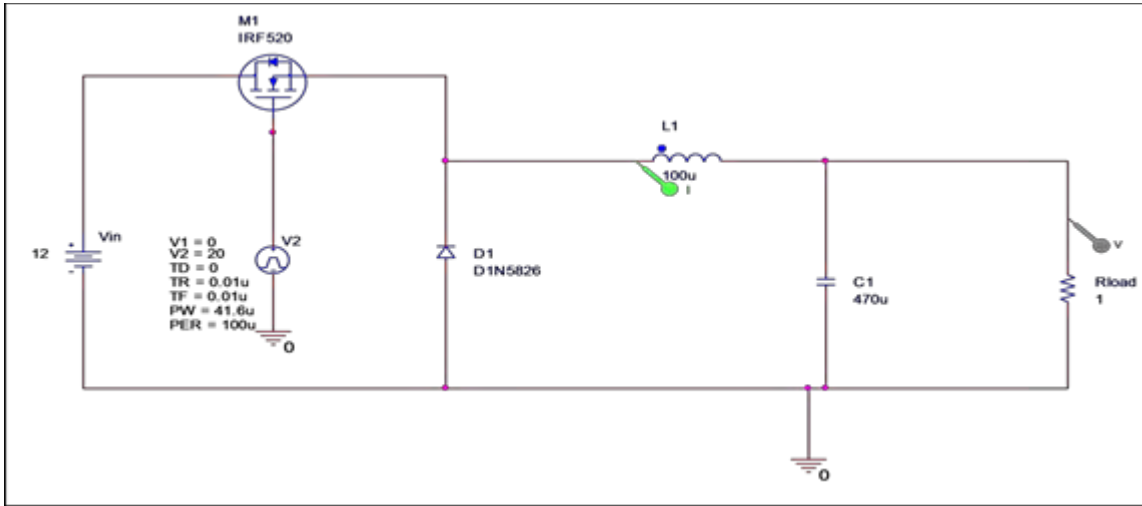

Figure No-3.1 :Pspice simulation of Buck converter.

Above figure no-3.1 shows the simulation circuit of buck converter. We used IRF 520 mosfet as a switch and a normal D1N5826 diode. We used 100 micro Henry inductor and 470 micro farad capacitor with an internal resistance of 0.1 ohm and load resistance of 1 ohm.

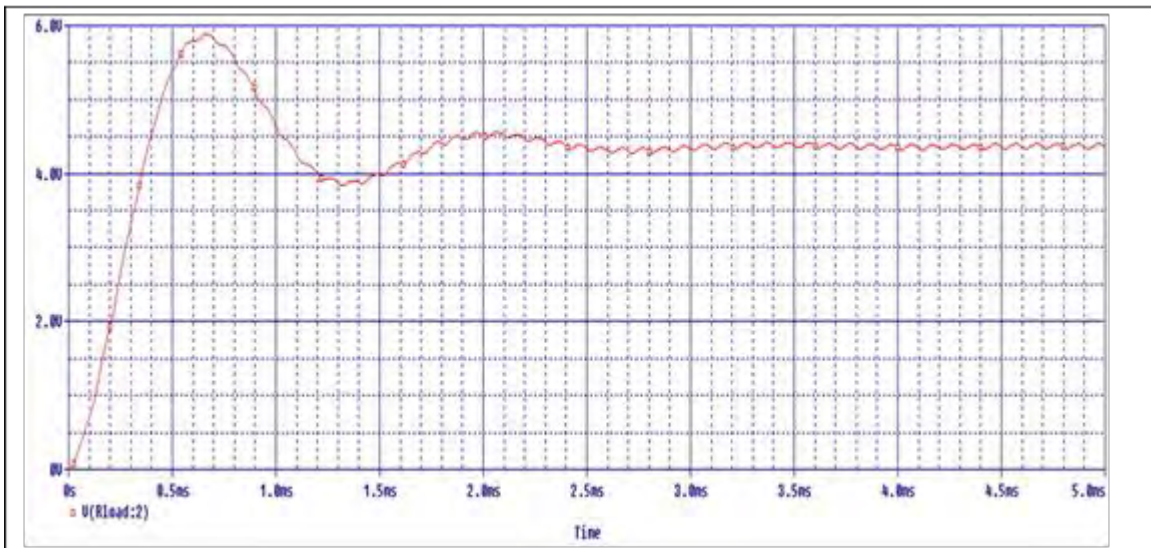

Figure No-3.2: Waveform of the voltage output

Here, above figure no-3.2 shows the output voltage waveform which at the beginning was a bit fluctuating but after some time it became steady at 5v which is a desired value.

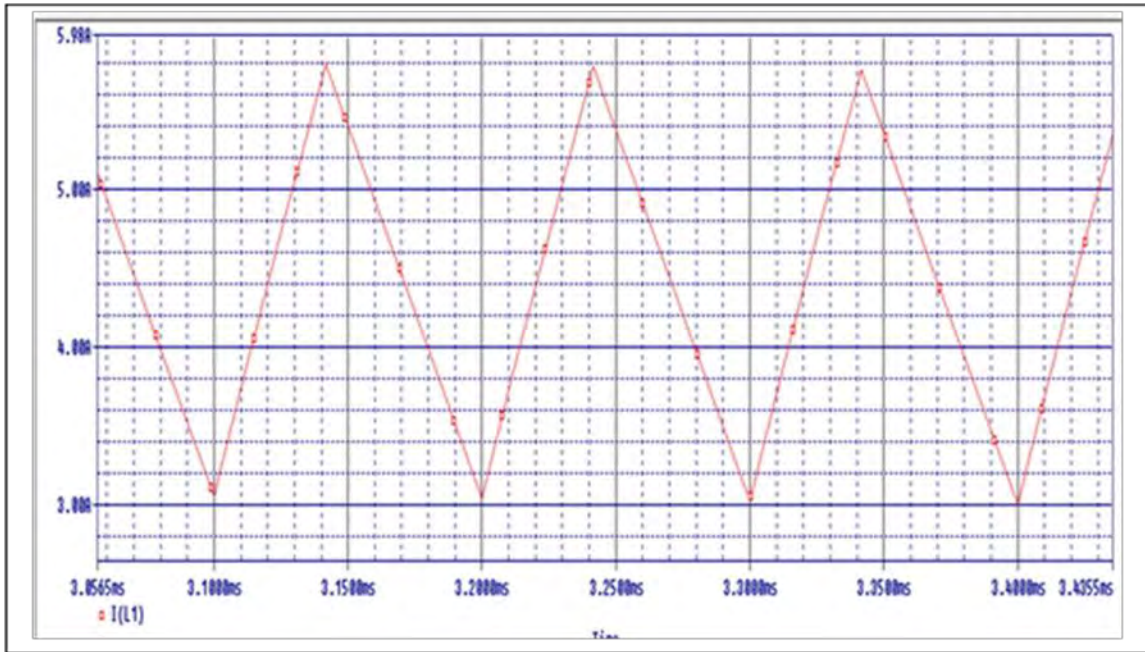

Figure No-3.3: Inductor current wave form

Here, above figure no-3.3 shows the inductor current waveform which is fluctuating between 3A to 5A which is also a desired value.

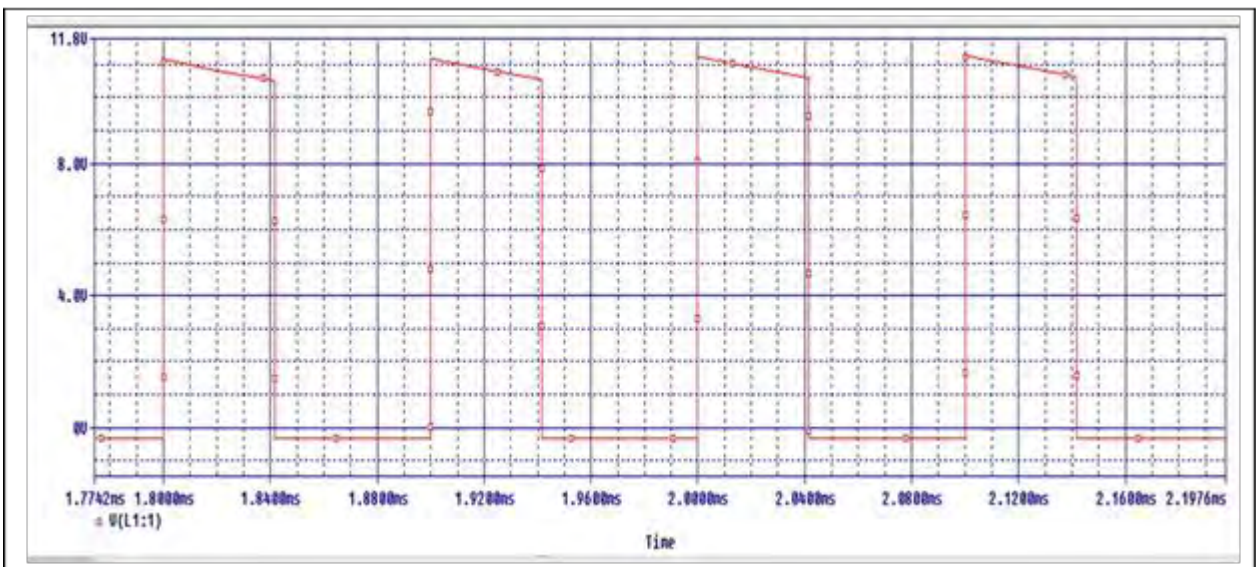

Figure No-3.4 : Diode voltage waveform.

Above figure no -3.4 shows the diode voltage waveform which is fluctuating between 0v to 11v which is also a desired value.

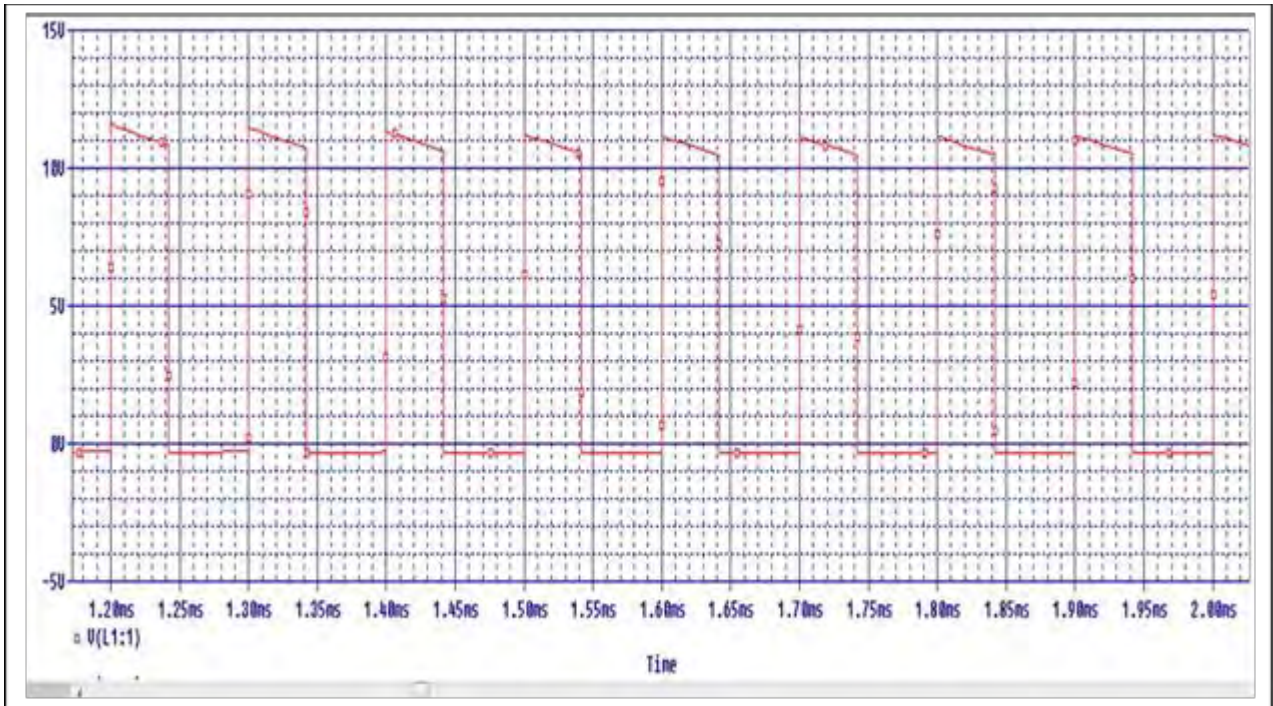

Figure No-3.5: Inductor voltage waveform

Here, above figure no-3.5 is showing the inductor voltage waveform which is fluctuating between 0v to 12v which is very much desired value for an input voltage of 12V.

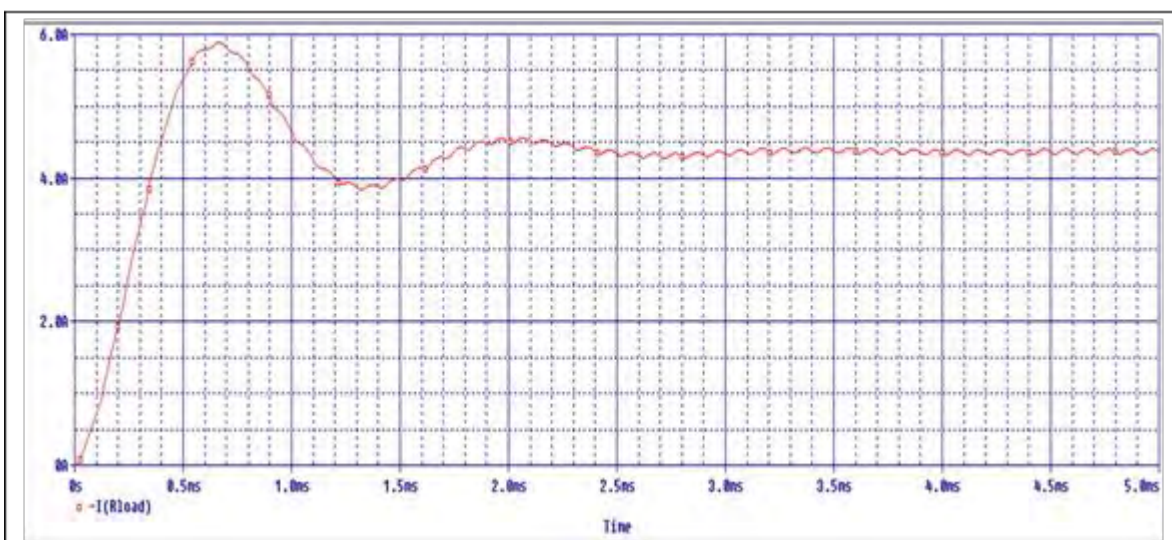

Figure No-3.6 : Output current waveform

29 | State space modeling of a buck converter and designing a controller

Here, in figure no-3.6 is the wave form of output current which is same as output voltage waveform fluctuating at the beginning but reached to a stable value of 5V.

Chapter 4:

4.1:

The Control Stage

Any converter which includes power electronic components has a critical part which is known as switch. We do usually use the following methods so that we can control the switching method,

1. Pulse Width Modulation Control
2. Frequency Modulation Control
3. Current Limit Control

Pulse width modulation is mostly used type for switching among all these three methods in our paper we will focus on pulse width modulation technique.

4.2:

Small Signal Modeling

To differentiate the straight forward circuit analysis with the equivalent model for semiconductors, PWM converters are used. These type of converters are nonlinear time varying systems. Small signal modeling is a random type of analyzing criteria which we use for determine the characteristics of a nonlinear equipment using the linear equations. The device had a DC bias point and in most cases the linearization is created about that point. The linearization can be accurately measured for a small deviation around this bias point. In practical case the model which covers the information about the behaviors of spatially distributed physical component system is called lumped modeling. The topology which means the geography of space has discrete entities for the approximation of behavior of distributed system following some assumption. VatcheVoperian first proposed the modeling procedure of small signal model which was primarily used for analysis. The analysis result was not satisfactory as mentioned by the author .as a result the TF model using time domain was not finished.

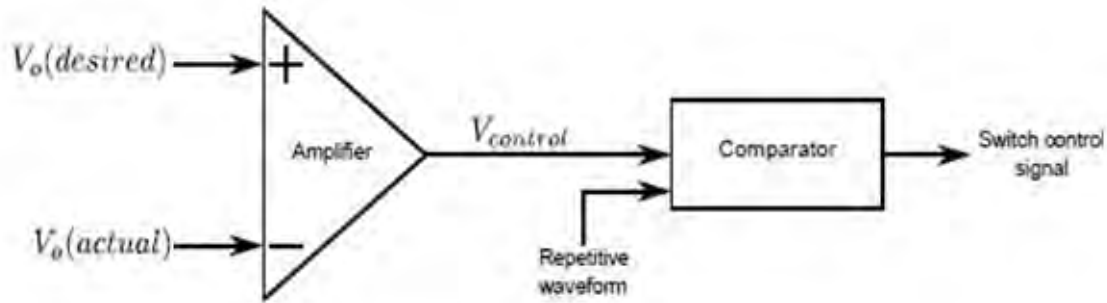

Figure No-4.1: Voltage Reference Comparator

4.3: PWM Controller and PWM

The controller circuit or the switching control circuit is the most important part of the buck converter. The controller circuit is mainly designed to get almost a constant output keeping the voltage regulation nil. A negative feedback control loop which is connected using a comparator circuit and a pulse width modulator (PWM) to the switch. The switch state (it is on or it is off) is controlled using the switch control signal. The unregulated output voltage is regulated by the control circuit while there is a change in the load and the input voltage. To control the updated power electronic circuits the PWM method comes first in the choice. To control the duty cycle of the switch so that a controllable average voltage is delivered to the load is the basic saying of the method to do this task we have to fix the switching frequency at high point where the load will not be able to see the individual switching tasks. The Repetition frequency for the PWM signal will react with the load at the average state of switches.

In PWM control method, the operational frequency will not be a variable while the duty cycle of the switch will be varied to obtain the regulated output voltage. The duty cycle is defined by the division of the on time period with the total time period in the PWM control system we can do the optimization of the LC filter and control the ripple current through the output within our limits and it is caused by the constant frequency set.

4.4:

Comparator and Voltage to PWM Converter

When there is some set values of output the switching power supply controls the voltage of output depending on the negative feedback system. There will be an error signal which we can find by differentiating the ideal output voltage with the practical output value. We will use a differential amplifier to our circuit to measure that error signal. If we compare a signal level control voltage with a repetitive waveform we will get the switching of the PWM .for that we will need a constant frequency. This is shown in above figure of voltage reference comparator.

The repetitive waveform will have a frequency that contains a constant peak will be represented as a sawtooth .it will rise the switching frequency. The frequency will be contend allover and the range should be in hundred KHz .the error signal (amplified), related to the switching frequency is less variable with respect to the time. When the sawtooth waveform is less than the amplified error signal, the switch control signal turns high .as a result the switch turns ON in other case the switch remains OFF. If the output voltage changes the control signal ($v_{control}$) will also change it results the variation in the threshold of the comparator to pull down the error signal to zero the control loop is to be completed.

The peak of sawtooth waveform and the $V_{control}$ can figure out the duty ratio which can be described as,

$$\begin{aligned} D &= t_{on}/T_s \\ &= v_{control}/V_{st} \dots \dots \dots (4.1) \end{aligned}$$

The waveforms signals are shown in the following figure no-4.2.

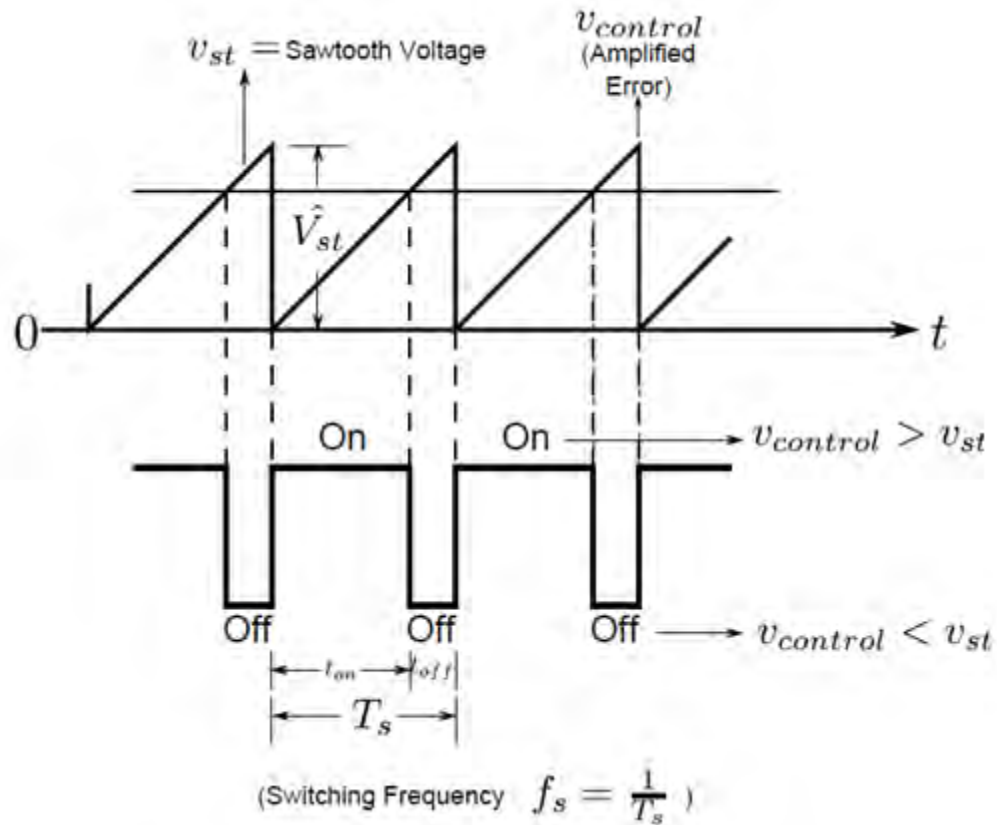

Figure No-4.2: PWM Comparator Signals

4.5: **Feedback Control System**

The output voltages of DC power supplies are regulated so that they stay in limited tolerance band as the output load and the input voltages changes. Using negative feedback system we will regulate the DC power supplies. The related diagram of feedback controller is given below.

It is often hard to model the nonlinear systems and sometimes it can be kind of impossible because nonlinear systems does not equate the summation of its parts. Also the systems shows highly uncertain response to the particular aspects at the time of modeling. Usually while modeling, assuming them as linear occurs where possible. To make the

calculations easier, In the linear type of modeling it is practicable to do some mathematical approximation .the nonlinear modeling do not give that facility.

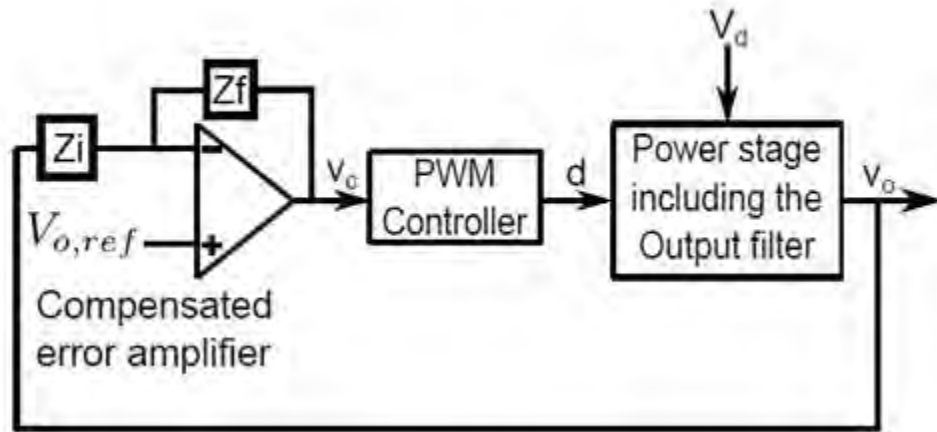

Figure No-4.3:Feedback Control System

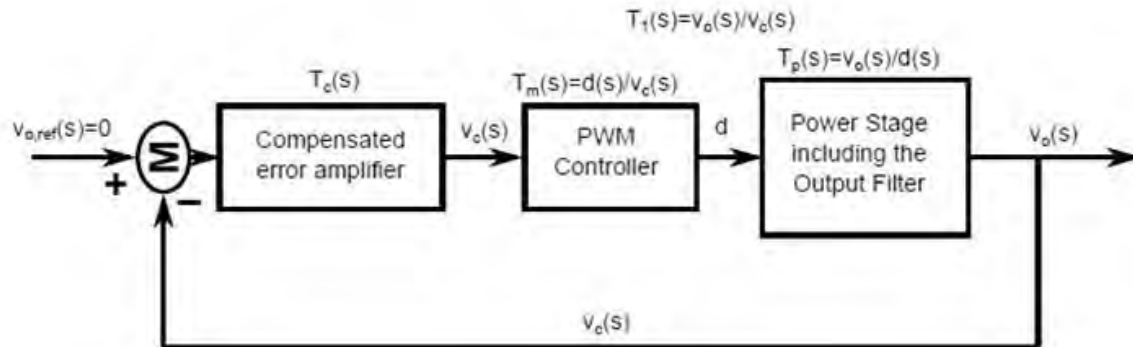

Figure No-4.4:Linearized Feedback Control System

Figures 4.3 and 4.4 shows the feedback control system and linearized feedback control system.

In above figure no-4.3 of the power stage of switch mode control of feedback control system is linearized. As we are using state space averaging method, to get the wanted steady state operating point we have to compensate the feedback loop with the suitable value .for doing that we will be using Nyquist stability criterion and the bode plot. Thus we can understand the theoretical settings of a converters frequency response, the feedback loop of the switch mode regulator as well as stability criteria.

R D Middlebrook, a member of power electronic group of California institute of technology proposed this technique of feedback control. Above figure about linearized feedback control can be stated by the transfer functions. A small signal transfer function $v_o(s)/d(s)$ will be defined after this analysis. The v_o and d are small perturbation in the output voltage and the duty ratio.

4.6: State Space Approach

4.6.1: The State Variables

In the continuous conduction mode the current in the energy transfer inductor never goes to zero between switching cycles in this phase there are 2 stages

- 1.ON state- switch is On .
- 2.OFF state- switch is OFF.

There are state variables to elaborate the states of linear circuits. The vector X has the inductor current I_L and the capacitor voltage V_c . There will also be description about the parasitic elements such as resistance with the inductors and the filter capacitors.

Here V_{in} is the input voltage. The lower suffix letter is used expresses a variable, which contains the steady state dc value of it and a small ac perturbation as well. Therefore during each circuit state, we can write the following state equations,

During $d.T_s$,

$$\dot{x} = A_1 x + B_1 v_g \dots\dots\dots(4.2) \quad [v_g = V_{in}]$$

$$v_o = C_1 x \dots\dots\dots(4.3) \quad [d = \text{duty ratio}]$$

During $(1-d).T_s$,

$$\dot{x} = A_2 x + B_2 v_g \dots\dots\dots(4.4)$$

$$v_o = C_2 x \dots \dots \dots (4.5)$$

Where A_1 and A_2 are state matrices and B_1 and B_2 are vectors, v_o and C_1 and C_2 are transposed vectors.

Averaging the State Variable Description using the Duty Ratio d

To produce an average description of the circuit over a switching period, the equations corresponding to the two foregoing states are time weighted and averaged, resulting in the following equations,

$$\dot{x} = [A_1 d + A_2 (1-d)]x + [B_1 d + B_2 (1-d)]v_g \dots \dots \dots (4.6)$$

and

$$v_o = [C_1 d + C_2 (1-d)]x \dots \dots \dots (4.7)$$

Introducing Small ac Perturbations and Separation into ac and dc Components

Small ac perturbations, represented by “ $\hat{}$ ”, are introduced in the dc steady – state quantities (which is represented by the upper case letters). Therefore,

$$x = X + \hat{x} \dots \dots \dots (4.8)$$

$$v_o = V_o + \hat{v}_o \dots \dots \dots (4.9)$$

and

$$d = D + \hat{d} \dots \dots \dots (4.10)$$

In general, $v_g = V_g + \hat{v}_g$. However, in view of our goal to obtain the transfer function between voltage v_o and the duty ratio d , the perturbation \hat{v}_g is assumed to be zero in the input voltage to simplify our analysis. Therefore,

$$v_g = V_g \dots \dots \dots (4.11)$$

Using Equations 4.8 through 4.11 in Equation 4.6 and recognizing that in steady state, $\dot{X} = 0$, we can write,

$$0 = AX + BV_g + A^{-1} [(A_1 - A_2)X + (B_1 - B_2)V_g \hat{d} + (\text{some terms}) \hat{d}] \dots \dots \dots (4.12)$$

The terms containing products of \hat{x} and \hat{d} are to be neglected.

Here,

$$A = A_1 D + A_2 (1-D) \dots \dots \dots (4.13)$$

and

$$B = B_1 D + B_2 (1-D) \dots \dots \dots (4.14)$$

The steady-state equation can be obtained from the equation 4.12 by setting all the perturbation terms and their derivatives to zero. Therefore, the steady – state equation is

$$A + BV_g = 0 \dots\dots\dots(4.15)$$

and therefore in Equation 4.12,

$$= A + [(A_1 - A_2)X + (B_1 - B_2)V_g] d \dots\dots\dots(4.16)$$

Similarly, using Equation 4.8 to 4.10 in equation 4.7 results in

$$V_o + \dot{v}_o = C_1 + C_2 + [(C_1 - C_2) d] \dots\dots\dots(4.17)$$

Where

$$C = C_1 D + C_2 (1 - D) \dots\dots\dots(4.18)$$

In equation 4.17, the steady-state output voltage is given by,

$$V_o = CX \dots\dots\dots(4.19)$$

and therefore,

$$\dot{v}_o = C + [(C_1 - C_2) d] \dots\dots\dots(4.20)$$

Using equations 4.15 and 4.19, the steady – state dc voltage transfer function can be found out and is given by,

$$V_o/V_g = -CA^{-1}B \dots\dots\dots(4.21)$$

Transformation of the ac equations in to s-Domain to solve for the Transfer Function

Equations 4.16 and 4.20 consist of the ac perturbations. Using Laplace transformation in equation 4.16, we get

$$s v(s) = A v(s) + [(A_1 - A_2)X + (B_1 - B_2)V_g] d(s) \dots\dots\dots(4.22)$$

or, we can write from [4.5],

$$v(s) = [sI - A]^{-1} [(A_1 - A_2)X + (B_1 - B_2)V_g] d(s) \dots\dots\dots(4.23)$$

Where I is a unity matrix. Using a Laplace transformation in equation 4.20 and expressing v(s) in terms of d(s) as given by the equation 4.23 results in the desired transfer function

$T_p(s)$ of the power stage:

$$T_p(s) = v_o(s)/d(s) = C[sI - A]^{-1} [(A_1 - A_2)X + (B_1 - B_2)V_g] + (C_1 - C_2)X \dots\dots\dots(4.24)$$

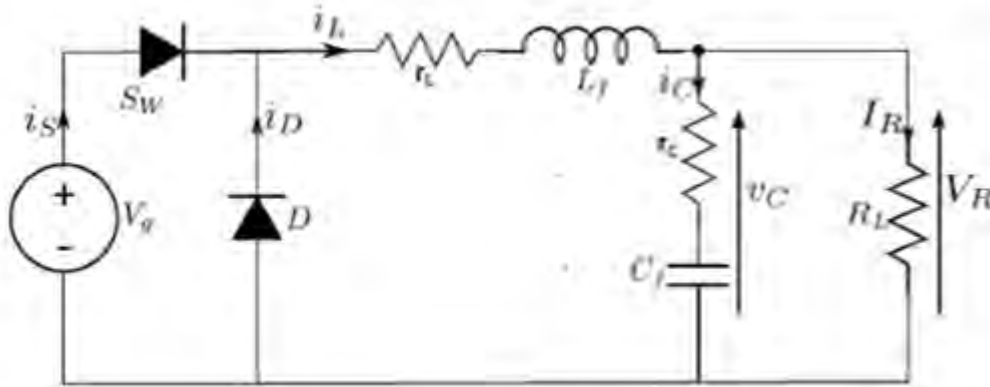

Figure No-4.5: Buck Converter Circuit

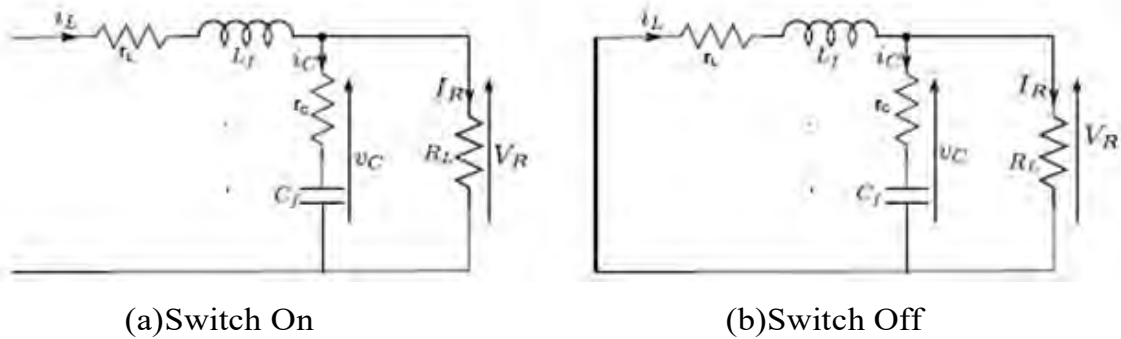

Figure No-4.6: Buck Converter (a) Switch On and (b) Switch Off

The power stage and the converters output filter will be linearized. Here the switch is stated by a diode. The inductor resistance R_1 and capacitor resistance R_c are the equivalent series resistances. The load resistance is R_L

The following equations are derived from the above figure 4.6. the capacitor voltage V_c and the inductor current I_L are the state variables because they describe the state of the circuit at the starting of simulation when time $t=0$ the inductor current and the initial capacitor voltage are signified using KCL and KVL in above figure circuit, we get,

$$r_L i_L + L_f \frac{di_L}{dt} = v_g - v_o = v_g - R_L (i_L - C_f \frac{dv_c}{dt}) \dots \dots \dots (4.25)$$

By voltage balance across the load, we get,

$$v_c + r_c C \frac{dv_c}{dt} = v_o = R_L (i_L - C_f \frac{dv_c}{dt}) \dots \dots \dots (4.26)$$

On rearranging equation 4.26, we get,

$$\frac{dv_c}{dt} = [R_L / C_f (r_c + R)] i_L - [1 / C_f (r_c + R)] v_c \dots \dots \dots (4.27)$$

Now substituting the value of dv_c/dt from equation 4.26 in equation 4.25, and rearranging the terms we get,

$$di_L/dt = -[\{(R_L r_c + R_L R_L + r_c r_L) i_L\} / L_f (r_c + R_L)] - [R_L / L_f (R_L + r_c)] v_c + (1/L_f) v_g \dots \dots \dots (4.28)$$

Now,

$$\begin{cases} x_1 = i_L \\ x_2 = v_c \end{cases} \dots \dots \dots (4.29)$$

So, we can write the state equations from the equation 4.28 and 4.27 in the form of a matrix as shown below,

$$\begin{bmatrix} \dot{x}_1 \\ \dot{x}_2 \end{bmatrix} = \begin{bmatrix} -\frac{R_L r_c + R_L R_L + r_c r_L}{L_f (r_c + R_L)} & -\frac{R_L}{L_f (R_L + r_c)} \\ \frac{R_L}{C_f (r_c + R_L)} & -\frac{1}{C_f (r_c + R_L)} \end{bmatrix} \begin{bmatrix} x_1 \\ x_2 \end{bmatrix} + \begin{bmatrix} \frac{1}{L_f} \\ 0 \end{bmatrix} V_g \dots \dots \dots (4.30)$$

Comparing the above equation 4.30 with equation 4.2 gives us,

$$A_1 = \begin{bmatrix} -\frac{R r_c + R r_L + r_c r_L}{L (r_c + R)} & -\frac{R}{L (R + r_c)} \\ \frac{R}{C (r_c + R)} & -\frac{1}{C (r_c + R)} \end{bmatrix} \dots \dots \dots (4.31)$$

and

$$B_1 = \begin{bmatrix} \frac{1}{L} \\ 0 \end{bmatrix} \dots \dots \dots (4.32)$$

The state equation for the circuit of figure 4.6(b), with the switch Off can be written by observation, noting that the circuit of the figure is exactly the same as the circuit of figure 4.6(a) with v_g set to zero.

$$A_2 = A_1 \dots \dots \dots (4.33)$$

$$B_2 = 0 \dots \dots \dots (4.34)$$

In both the cases figure 4.6(a) and 4.6(b), the output voltage is given by, $v_o = R_L (i_L - C_f dv_c/dt)$(4.35)

Now, using the value of dv_c/dt from equation 4.27, we get,

$$v_o = [R_L r_c / (r_c + R_L)] i_L + [R_L / (r_c + R_L)] v_c \dots \dots \dots (4.36)$$

This can be written in terms of the state variables with the notation given by equation 4.29, as

$$v_o = \begin{bmatrix} \frac{R_L r_c}{r_c + R_L} & \frac{R_L}{r_c + R_L} \end{bmatrix} \begin{bmatrix} x_1 \\ x_2 \end{bmatrix} \dots \dots \dots (4.37)$$

Therefore, from equations 4.3 and 4.5, we can write,

$$C_1 = C_2 = \begin{bmatrix} \frac{R_L r_c}{r_c + R_L} & \frac{R_L}{r_c + R_L} \end{bmatrix} \dots \dots \dots (4.38)$$

Now, inserting the value of A_2 from equation 4.33 in equation 4.13 and simplifying, we get,

$$A = A_1 \dots \dots \dots (4.39)$$

Inserting the value of B_2 from equation 4.34 in equation 4.14 and simplifying, we get,

$$B = B_1 D \dots \dots \dots (4.40)$$

Inserting the value C_2 from equation 4.38 in equation 4.18 and simplifying, we get,

$$C = C_1 \dots \dots \dots (4.41)$$

In all the practical circuits we deal, we have,

$$R_L \gg \gg (r_c + r_L) \dots \dots \dots (4.42)$$

Therefore, A and C are simplified as,

$$A = A_1 = A_2 \cong \begin{bmatrix} -\frac{r_c + r_L}{L_f} & -\frac{1}{L_f} \\ \frac{1}{C_f} & -\frac{1}{C_f R_L} \end{bmatrix} \dots \dots \dots (4.43)$$

and

$$C = C_1 = C_2 \cong \begin{bmatrix} r_c & 1 \end{bmatrix} \dots \dots \dots (4.44)$$

and B remains unaffected as,

$$\mathbf{B} = \mathbf{B}_1 D = \begin{bmatrix} \frac{1}{L_f} \\ 0 \end{bmatrix} D \dots\dots\dots(4.45)$$

Where $B_2=0$ from the equation 4.34.

$$\mathbf{A}^{-1} = \frac{Adj(\mathbf{A})}{|\mathbf{A}|} = \frac{\begin{bmatrix} -\frac{1}{C_f R_L} & \frac{1}{L_f} \\ -\frac{1}{C_f} & -\frac{r_C+r_L}{L_f} \end{bmatrix}}{\left(\frac{r_L+r_C+R_L}{L_f C_f R_L}\right)} \dots\dots\dots(4.46)$$

On simplification of equation 4.46 we get,

$$\mathbf{A}^{-1} = \frac{L_f C_f}{1+(r_C+r_L)/R_L} \begin{bmatrix} -\frac{1}{C_f R_L} & \frac{1}{L_f} \\ -\frac{1}{C_f} & -\frac{r_C+r_L}{L_f} \end{bmatrix} \dots\dots\dots(4.47)$$

Now, from equation 4.21, we get,

4.7: Model Simplification

$$\frac{V_o}{V_g} = - \begin{bmatrix} r_C & 1 \end{bmatrix} \cdot \frac{L_f C_f}{1+(r_C+r_L)/R_L} \begin{bmatrix} -\frac{1}{C_f R_L} & \frac{1}{L_f} \\ -\frac{1}{C_f} & -\frac{r_C+r_L}{L_f} \end{bmatrix} \cdot \begin{bmatrix} \frac{1}{L_f} \\ 0 \end{bmatrix} D$$

Our simplification,

$$\frac{V_o}{V_g} = -D \frac{L_f C_f R_L}{R_L+r_C+r_L} \cdot \begin{bmatrix} -\frac{R_L+r_C}{L_f R_L C_f} \end{bmatrix} \dots\dots\dots(4.49)$$

Finally,

$$V_o/V_g = -[D\{(L_f C_f R_L)/(R_L + (r_c + r_L))\}] \cong D \dots \dots \dots (4.50)$$

Now, substituting the values of $A_1, A_2, B_1, B_2, A, C, C_1$ and C_2 from the above equations, into equation 4.24 we get,

$$\begin{aligned} T_p(S) &= V_o(S)/d(S) \\ &= V_g(1 + sC_f r_c + (L_f/R_L))/L_f C_f [s^2 + s((1/R_L C_f) + (r_c + (r_L/L_f))) + ((1/L_f C_f) + ((r_c + r_L)/R_L L_f C_f))] \end{aligned} \dots \dots \dots (4.51)$$

Now, approximating the above equation, for simplified result, we get,

$$\begin{aligned} T_p(S) &= V_o(S)/d(S) \\ &= V_{in}(1 + sC_f r_c + (L_f/R_L))/L_f C_f [s^2 + s((1/R_L C_f) + (r_c r_L/L_f)) + ((1/L_f C_f) + ((r_c + r_L)/R_L L_f C_f))] \end{aligned} \dots \dots \dots (4.52)$$

The equation 4.52, represents the open loop transfer function of the circuit represented by the figure 4.5. The terms in the big bracket in the denominator of the above equation are of the form, $s^2 + 2\xi \omega_n s + \omega_n^2$.

$$\omega_n = 1/\sqrt{L_f C_f} \dots \dots \dots (4.53)$$

$$\xi = [(1/RLC_f) + (r_c + r_L/L_f)] / 2\omega_n \dots \dots \dots (4.54)$$

So, we can conclude that,

$$\omega_n = f(L_f, C_f) = FL_f C_f \dots \dots \dots (4.55)$$

Now the equivalent series resistance (ESR) of the filter capacitor is r_c . So, let us choose ω_p such that,

$$\begin{aligned} \omega_p &= 1/C_f r_c \\ &= f(C_f r_c) = F_{ESR} \dots \dots \dots (4.56) \end{aligned}$$

Now the transfer function of equation 4.52 becomes,

$$\begin{aligned} T_p(S) &= V_o(S)/d(S) \\ &= V_{in} (\omega_n^2 / \omega_p) [(s + \omega_p) / (s^2 + 2\xi \omega_n s + \omega_n^2)] \dots \dots \dots (4.57) \end{aligned}$$

By the analysis the transfer function is,

$$T_p(S) = V_{in} K_p (s + z_1) / [1 + (s/p_1) + (s^2/p_2)] \dots \dots \dots (4.58)$$

Where,

$$K_p = [r_c R_L C_f (r_c + R_L)] / [L_f C_f (R_L r_c + R_L L_f + r_c R_L) (r_c + R_L) + (r_c + R_L) R_L^2] \dots \dots \dots (4.59)$$

$$z_1 = (R_L r_C + R_L^2) / [r_C R_L C_f (r_C + R_L)] \dots\dots\dots(4.60)$$

$$P_1 = ((L_f C_f (R_L r_C + R_L r_L + r_C r_L) (r_C + R_L)) + ((r_C + R_L) R_L^2)) / L_f C_f (r_C + R_L)^2 [C_f (R_L r_C + R_L r_L + r_C r_L) + L_f] \dots\dots\dots(4.61)$$

$$P_2 = ((L_f C_f (R_L r_C + R_L r_L + r_C r_L) (r_C + R_L)) + ((r_C + R_L) R_L^2)) / L_f^2 C_f^2 (r_C + R_L)^3 \dots\dots\dots(4.62)$$

4.8:

The Pulse Width Modulator

In the direct duty PWM, the control voltage $V_c(t)$, which is the output of the error amplifier, is compared with a continuous reference waveform $V_r(t)$, which is the output of the error amplifier, is compared with a continuous waveform $V_r(t)$, which establishes the switching frequency F_{sw} , as shown in the figure 4.7. The control voltage $V_c(t)$ consists of a dc component and a small ac related component,

$$V_c(t) = V_c + v_c(t) \dots\dots\dots(4.63)$$

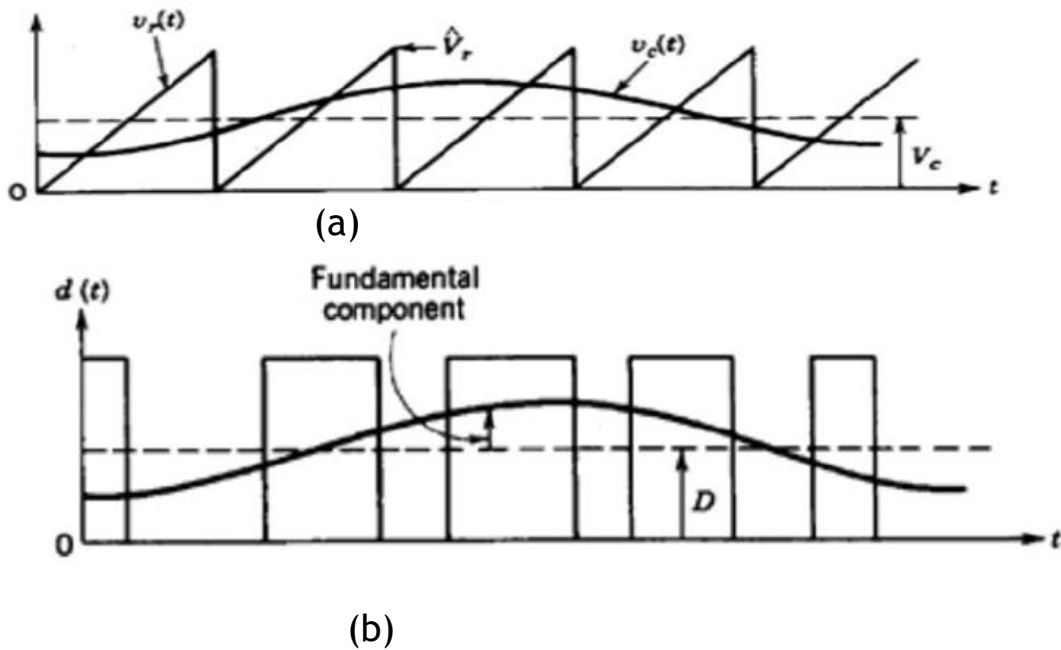

Figure no -4.7: pulse width modulator

Where, $V_c(t)$ is in a range between zero and V_r as shown in the figure 4.7. Here $v_c(t)$ assumed to be a sinusoidal ac perturbation in the control voltage at a frequency ω_x , where ω_x is much smaller than the switching frequency $F_{sw}(= 2\pi F_{sw})$.

The ac related part in the control voltage can be expressed as,

$$v_c(t) = a' \cdot \sin(\omega_x t - \phi) \quad \dots\dots\dots(4.64)$$

by means of an amplitude a' and an arbitrary phase angle ϕ .

In figure 4.7, the instantaneous switch duty ratio $d(t)$ is as follows:

$$d(t) = \begin{cases} 1.0 \\ 0 \end{cases} \quad \dots\dots\dots(4.65)$$

In the figure 4.7, we have assumed that the sawtooth waveform $v_{saw}(t)$ has minimum value zero, and hence the duty cycle will be zero whenever $v_c(t)$ is less than or equal to zero. The duty cycle will be $D=1$ whenever $v_c(t)$ is greater than or equal to V_r . If, over a given switching period, $v_{saw}(t)$ varies linearly with t , then for $0 \leq v_c(t) \leq V_r$ the duty cycle will be a linear function of v_c . Hence we can write,

$$d(t) = v_c(t)/V_r \text{ for } 0 \leq v_c(t) \leq V_r \quad \dots\dots\dots(4.66)$$

So, if we represent the waveform of $V_c(t)$ in terms of Fourier the $d(t)$ looks like,

$$D(t) = V_c/V_r + a'/V_r \sin(\omega_x t - \phi) + \text{other high frequency components.} \quad \dots\dots\dots(4.67)$$

The high frequency components in the output voltage V_o due to the high frequency components in $d(t)$ are eliminated because of the low-pass filter at the output of the converter. Therefore, the high-frequency components in equation 4.67 can be ignored. Now, adding and expanding the value of $d(t)$ in terms of its DC value and its ac related part we get,

$$D(t) = D + d(t) \quad \dots\dots\dots(4.68)$$

Now comparing equation 4.68 and 4.67 results,

$$D = V_c/V_r \quad \dots\dots\dots(4.69)$$

and

$$D(t) = a'/V_r \sin(\omega_x t - \phi) \quad \dots\dots\dots(4.70)$$

From the equation 4.64 and 4.70 we get,

$$D(t)/v_c(t) = 1/V_r \quad \dots\dots\dots(4.71)$$

Converting the equation 4.71 into S domain we get,

$$T_c(S) = d(S)/v_c(S)$$

$$= 1/V_r \dots \dots \dots (4.72)$$

Equation 4.72 gives the transfer function of the pulse width modulator.

4.9: Bode Plot of the Filter Circuit:

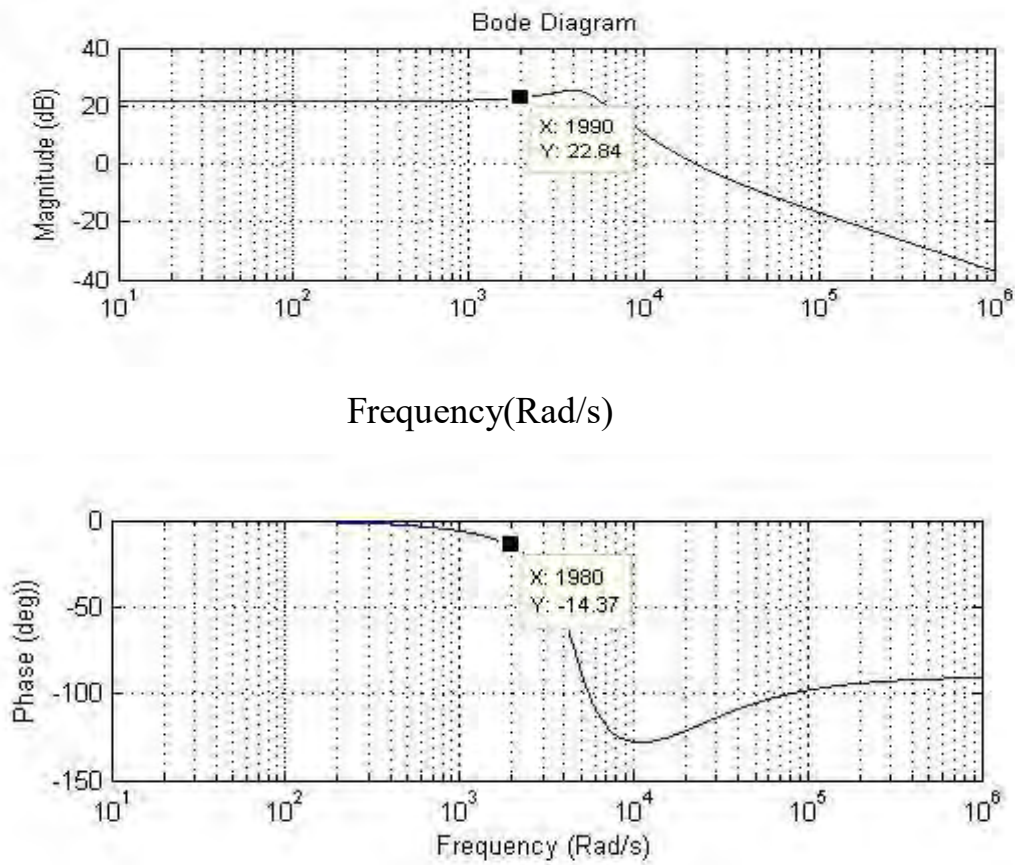

Figure No-4.8: Bode Plot of Buck Converter Transfer Function

4.10:

Calculation of Transfer Function:

Switching frequency, $F_{sw} = 10 \text{ kHz}$

Crossover frequency, $F_{co} = (1/5)$ of $F_s = 2 \text{ KHz}$

At 14 KHz, filter gain is 22.84dB and phase is -14.37° .

Pulse of PWM, $V_p = 3$

PWM gain = $1/V_p = -9.54 \text{ dB}$

Combined gain = $(-9.54 + 22.84) \text{ dB} = 13.3 \text{ dB}$

So, compensator gain should be -13.3 dB to make the overall gain 0 [13].

$$-13.3 = 20 \log (V_c/V_o)$$

$$(V_c/V_o) = 0.216$$

So, the magnitude of the mid frequency gain is,

$$(R_2/R_1) = 0.216$$

$$R_1 = 1 \text{ k}$$

$$R_2 = 0.216 \text{ k}$$

$$\theta_{comp} = \theta_{phase} - \theta_{filter}$$

$$= 45^\circ - (-14.37^\circ)$$

$$= 59.37^\circ$$

$$K = \tan \left(\frac{\theta_{comp}}{2} \right) = 0.57$$

$$C1 = \frac{K}{2\pi f_{co} R_2} = 210 \text{ nF}$$

$$C2 = \frac{1}{K 2\pi f_{co} R_2} = 646 \text{ nF}$$

4.11:

Transfer Function of the Compensator:

Type II Compensator Transfer Function

$$\frac{1+sR2C1}{sR1(C1+C2)(1+sR2(\frac{C1C2}{C1+C2}))} = \frac{S+22.03 \times 10^3}{18.85S+6.454 \times 10^{-4}S^2}$$

4.12:

Bode Plot of the Compensator:

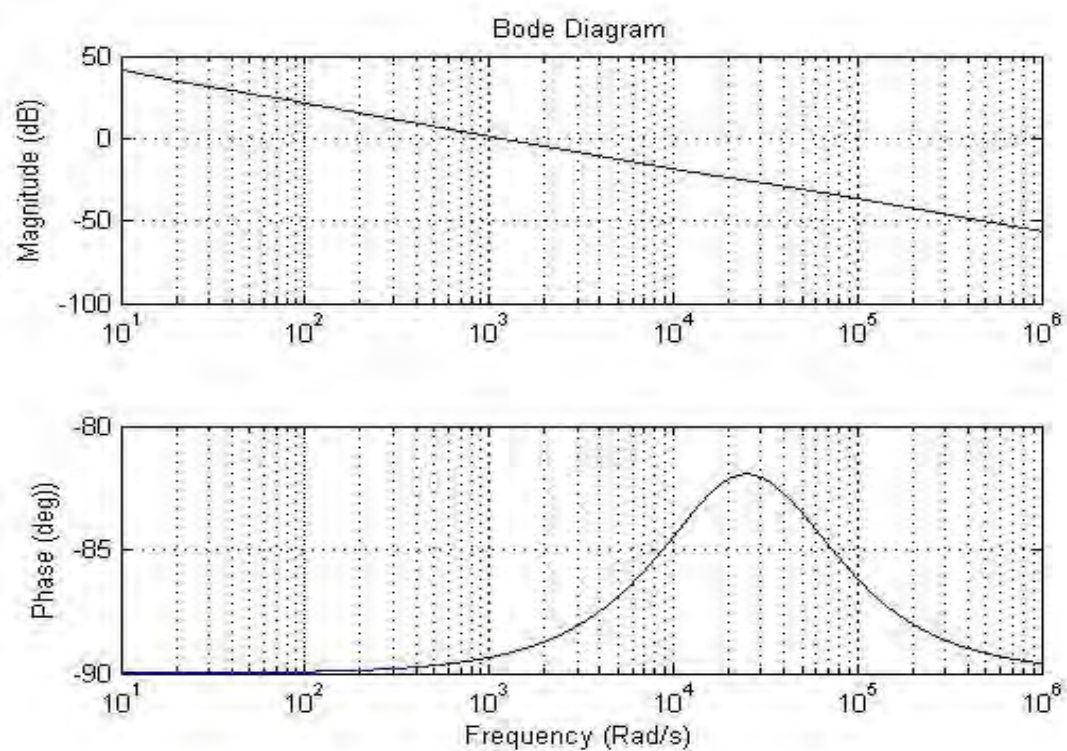

Figure No-4.9:Compensator Bode Plot

4.13:
Simulation of the Feedback with Filter Network:

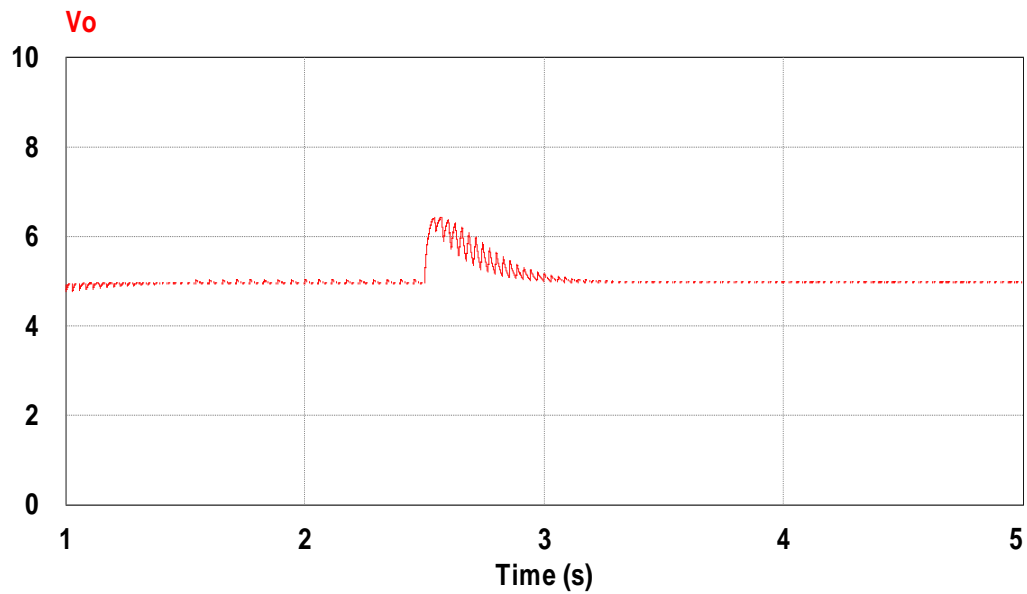
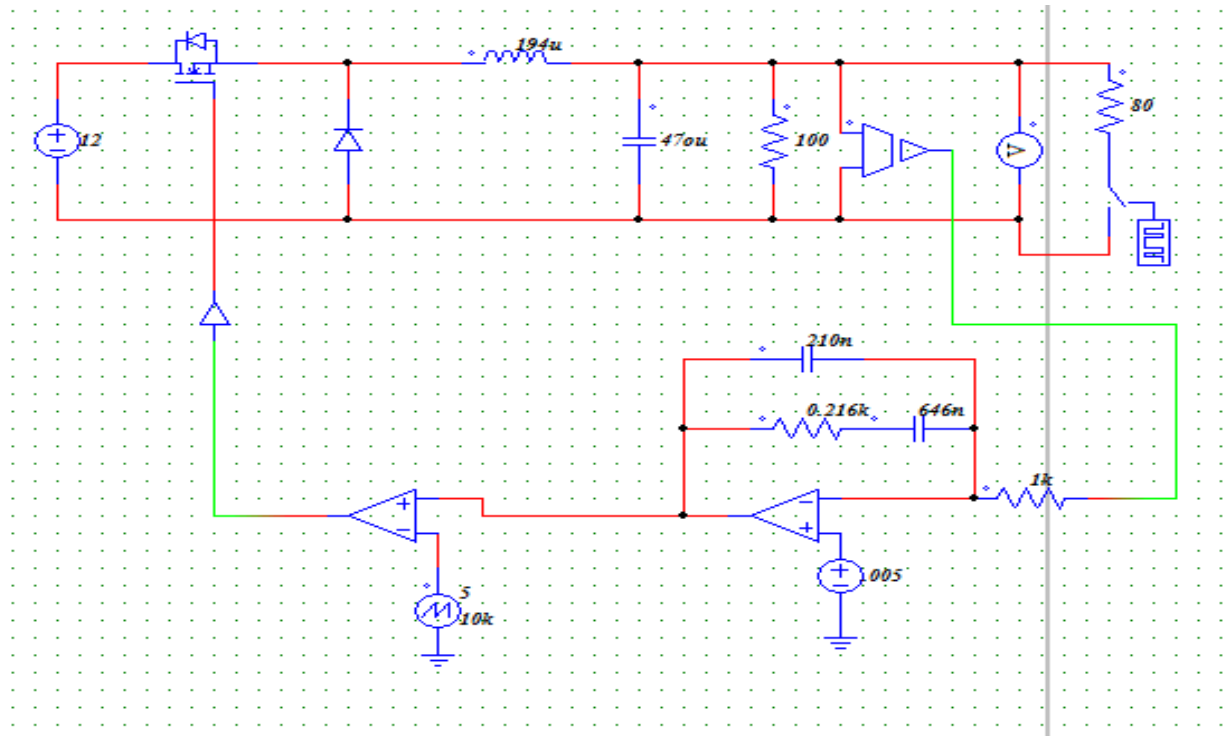

Figure No-4.10: Output voltage with variable load correction

Chapter -5:

5.1:

Future Scopes:

Even though the proposed objectives for our thesis have been met, there are still many improvements that could be done for this project. The project is far from completed since much improvement could be done to increase the reliability and accuracy of the converter. Because the technology is still improving over the years, there are many types of configuration for buck converter control available in the market. For instance, there are synchronous buck converter, peak-current control buck converter etc.

Thus, this project could be expanded by implementing peak-current mode control or synchronous buck configuration into the voltage-mode control buck converter for improvement in the controlling the output voltage. By improving the control method for the buck converter, the complexity of the design will arise, thus it will need some study to be done in the future for such improvement.

Finally, even after such improvement, there will be more studies that could be done to improve the efficiency and reliability of the converter. The method of controlling the MOSFET by using pulse-width modulation generated by the microcontroller is one such study that could be done in the future.

5.2:

Conclusion

To conclude our main idea was to build a design for voltage mode control of a buck converter to control the output automatically by adjusting the duty cycle to regulate the output voltage in a significant level we used the closed loop circuit which made the task simpler.

Voltage mode control does sense the variation in output and input signals. Besides the process can be elaborated by others methods. As an example peak current control method, synchronous buck configuration etc. These methods of controlling may be complicated because a vast amount of research are needed. The voltage mode modeling and controller design is less expensive and less complex. This circuit observes the change in voltages and using feedback system it regulates the output.

Lastly we had to deal with many obstacles with finding the research materials for finding information and the answers of our problems. Moreover it was very hard for us to work beside our regular courses and in limited time frame it taught us the lesson how to work in a group and the management of time during the working period.

5.3:

REFERENCES:

BOOKS:

- [1] Ned Mohan, Tore M. Undeland, William P. Robbins, “*Power Electronics: Converters, Applications, and Design*”, 3rd Edition, Wiley
- [2] B. J. Baliga, “*Modern Power Devices*”, New York: Wiley, 1987.
- [3] Daniel W. Hart “*Power Electronics*”, *New York : Mcgraw-Hill, 2011*

PAPERS:

- [4] Jinwen Xiao, Angel Peterchev, Jianhui, Seth Sanders, “*An Ultra-Low-Power Digitally-Controlled Buck Converter IC for Cellular Phone Applications*”, Applied Power Electronics Conference and Exposition, 2004. Nineteenth Annual IEEE, Volume 1, Issue, 2004 Page(s): 383 - 391 Vol.1
- [5] Chin Chang, “*Robust Control of DC-DC Converters: The Buck Converter*”, Power Electronics Specialists Conference, 1995. 26th Annual IEEE Volume 2, issue , 18-22 Jun 1995 Page(s):1094 - 1097 vol.2.
- [6] Mika Sippola and Raimo Sepponen, “*DC/DC Converter technology for distributed telecom and microprocessor power systems – a literature review*”, Helsinki University of Technology Applied Electronics Laboratory, Series E: Electronic Publications E 3, 2002
- [7] Kumar G Ajay, Suryanarayan, “An in depth analysis of Buck Converter Design”

WEBSITES:

- [8] Michael Day, “*Optimizing Low-Power DC/DC Designs – External versus Internal Compensation*”, Texas Instruments Incorporated ©2004. Available at: <http://focus.ti.com/lit/ml/slyp090/slyp090.pdf>
- [9] http://services.eng.uts.edu.au/~venkat/pe_html/ch07s1/ch07s1p1.htm
- [10] <http://www.rason.org/Projects/swregdes/swregdes.htm>
- [11] http://www.maxim-ic.com/appnotes.cfm/appnote_number/751
- [12] http://powerelectronics.com/mag/power_buck_converter_losses/index.html
- [13] <http://www.irf.com/technical-info/appnotes/mosfet.pdf>

[14] Frank De Stasi & Mathem Jacob, “*Magnetic Buck Converters for Portable Applications*”, National Semiconductor. Available at:
http://www.national.com/appinfo/power/files/buck_converters.pdf

[15] Robert V. White, “*Digital Control Concepts For Power Supply Engineers*”, Worldwide Technology Group. Available at: [http://www-03.ibm.com/procurement/proweb.nsf/objectdocswebview/file8+-+bob+white+digital+control+concepts+presentation/\\$file/8++bob+white+digital+control+concepts+presentation+20060829.pdf](http://www-03.ibm.com/procurement/proweb.nsf/objectdocswebview/file8+-+bob+white+digital+control+concepts+presentation/$file/8++bob+white+digital+control+concepts+presentation+20060829.pdf)

[16] Volkan Kursun, Siva G. Narendra, Vivek K. De, and Eby G. Friedman, “*Efficiency Analysis of a High Frequency Buck Converter for On-Chip Integration with a Dual-VDD Microprocessor*”, Solid-State Circuits Conference, 2002. ESSCIRC 2002. Proceedings of the 28th European, Page(s): 743 – 746

