

DESIGN AND IMPLEMENTATION OF SMART TRANSPORT MONITORING SYSTEM TO ENSURE PASSENGER'S SAFETY

By

Anika Binte Aman

20221040

Nushin Nawar

20321057

Safayed Maruf Hossain

19121039

MD. Zakir Hossain

19121122

A Final Year Design Project (FYDP) submitted to the Department of Electrical and Electronics Engineering in partial fulfillment of the requirements for the degree of Bachelor of Science in Electrical and Electronics Engineering

Electrical and Electronics Engineering

Brac University

December, 2023

DESIGN AND IMPLEMENTATION OF SMART TRANSPORT MONITORING SYSTEM TO ENSURE PASSENGER'S SAFETY

By

Anika Binte Aman

20221040

Nushin Nawar

20321057

Safayed Maruf Hossain

19121039

MD. Zakir Hossain

19121122

Academic Technical Committee (ATC) Panel Member:

Dr. Md. Mosaddequr Rahman

Professor and Chairperson, Department of EEE, BRAC University

Mohaimenul Islam (Member)

Lecturer, Department of EEE, BRAC University

Aldrin Nippon Bobby (Member)

Lecturer, Department of EEE, BRAC University

Electrical and Electronics Engineering

Brac University

December, 2023

© 2023. Brac University

All rights reserved.

Declaration

It is hereby declared that

1. The Final Year Design Project (FYDP) submitted is my/our own original work while completing degree at Brac University.
2. The Final Year Design Project (FYDP) does not contain material previously published or written by a third party, except where this is appropriately cited through full and accurate referencing.
3. The Final Year Design Project (FYDP) does not contain material which has been accepted, or submitted, for any other degree or diploma at a university or other institution.
4. I/We have acknowledged all main sources of help.

Student's Full Name & Signature:

Anika Binte Aman
20221040

Nushin Nawar
20321057

Safayed Maruf Hossain
19121039

MD. Zakir Hossain
19121122

Approval

The Final Year Design Project (FYDP) titled “Design and Implementation of Smart Transport Monitoring System to Ensure Passenger’s Safety,” submitted by

1. Anika Binte Aman (20221040)
2. Nushin Nawar (20321057)
3. Safayed Maruf Hossain (19121039)
4. MD. Zakir Hossain (19121122)

of Fall, 2023 has been accepted as satisfactory in partial fulfillment of the requirement for the degree of Bachelor of Science in Electrical and Electronics Engineering on 28/12/2023.

Examining Committee:

Academic Technical
Committee (ATC):
(Chair)

Dr. Md. Mosaddequr Rahman
Professor and Chair, Department of EEE
BRAC University

Final Year Design Project
Coordination Committee:
(Chair)

Dr. Abu S.M. Mohsin Associate
Professor, Department of EEE
BRAC University

Department Chair:

Dr. Md. Mosaddequr Rahman
Professor, Department of EEE
BRAC University

Ethics Statement

Our final year design project report contains 21% plagiarism

Abstract/ Executive Summary

In the era of smart cities and advanced transportation systems, ensuring the safety, efficiency, and reliability of public transportation is of paramount importance. This paper presents the design and implementation of an intelligent bus monitoring system that leverages cutting-edge technologies to enhance the overall functionality of buses. The system integrates GPS-based location tracking, image processing for passenger counting, an online ticketing system through website and a suite of safety sensors. These sensors include ultrasonic sensors for object detection, gas sensors for detecting leaks, and an accident detector. In the unfortunate event of an accident, the system promptly notifies the bus administration by transmitting the precise location coordinates. This project, which is academically demanding, seeks to transform public transportation by offering up-to-date information and taking proactive steps to ensure safety.

Keywords: GPS (Global Positioning System); Image processing; Ultrasonic sensor; Gas sensor; Ticketing System

Acknowledgement

We extend our sincerest appreciation to the esteemed ATC panel members, Department of Electrical and Electronics Engineering, whose guidance has been pivotal in shaping our paths to success. We are profoundly grateful to BRAC University for cultivating an environment that nurtures growth and learning. To our esteemed peers, your unwavering support and shared dedication to excellence have made this journey profoundly enriching. Our heartfelt thanks to all contributors to our collective learning and development.

Table of Contents

Chapter 1: Introduction [CO1, CO2, CO3, CO10]	14
1.1 Introduction	14
1.1.1 Problem Statement	14
1.1.2 Background Study	16
1.1.3 Literature Gap	19
1.1.4 Relevance to Current and Future Industry	19
1.2 Objectives, Requirement, Specification and Constraint	21
1.2.1 Objectives	21
1.2.2 Functional and non-functional Requirements	21
1.2.3 Specifications	22
1.2.4 Technical and Non-technical consideration and constraints in design Process	23
1.2.5 Applicable compliance, standards, and codes	25
1.3 Systematic Overview/summary of the proposed project	26
1.4 Conclusion	27
Chapter 2: Project Design Approach [CO5, CO6]	28
2.1 Introduction	28
2.2 Identify Multiple Design Approach	28
2.3 Describe Multiple Design Approach	28
2.3.1 Overview of Approach 1	28
2.3.2 Overview of Approach 2	30

2.4 Analysis of Multiple Design Approach	31
2.5 Conclusion	33
Chapter 3: Use of Modern Engineering and IT Tool [CO9]	34
3.1 Introduction	34
3.2 Select Appropriate Engineering and IT Tools	34
3.3 Use of Modern Engineering and IT Tools	34
3.4 Conclusion	39
Chapter 4: Optimization of Multiple Design and Finding the Optimal Solution [CO5, CO6, CO7]	40
4.1 Introduction	40
4.2 Optimization of Multiple Design Approach	40
4.2.1 Optimization of design approach 1	40
4.2.2 Optimization of design approach 2	46
4.3 Identify Optimal Design Approach	53
4.4 Performance Evaluation of Developed Solution	54
4.5 Conclusion	55
Chapter 5: Completion of Final Design and Validation [CO8]	56
5.1 Introduction	56
5.2 Completion of Final Design	56
5.2.1 Methodology	57
5.2.2 Developed Prototype	58

5.3 Evaluate the Solution to Meet Desired Need	60
5.3.1 Verification of the prototype	60
5.4 Conclusion	65
Chapter 6: Impact Analysis and Project Sustainability [CO3, CO4]	66
6.1 Introduction	66
6.2 Assess the Impact of Solution	66
6.3 Evaluate the Sustainability	68
6.4 Conclusion	69
Chapter 7: Engineering Project Management [CO11, CO14]	70
7.1 Introduction	70
7.2 Define, Plan, Manage Engineering Project	70
7.3 Evaluate Project Progress	74
7.4 Conclusion	75
Chapter 8: Economical Analysis [CO12]	76
8.1 Introduction	76
8.2 Economic analysis	76
8.3 Cost benefit analysis	78
8.4 Evaluate economic and financial aspects	78
8.5 Conclusion	79
Chapter 9: Ethics and Professional Responsibilities [CO13, CO2]	80
9.1 Introduction	80

9.2 Identify Ethical Issues and Professional Responsibilities	80
9.3 Apply Ethical Issues and Professional Responsibilities	80
9.4 Conclusion	84
Chapter 10: Conclusion and Future Work.	85
10.1 Project summary/Conclusion	85
10.2 Future work	85
Chapter 11: Identification of Complex Engineering Problems and Activities.	87
11.1 Identify the attribute of complex engineering project	87
11.2 Provide reasoning how the project address selected attribute (EP)	88
11.3 Identify the attributes of complex engineering activities	89
11.4 Provide reasoning how the project address selected attribute (EA)	90
References	91
Appendix	93

List of Tables:

Table 1.1: This table shows comparison of transit share for different income groups.	17
Table 1.2: This table shows the functional and non-functional requirements of the project	22
Table 1.3: This table shows the specifications of the project	23
Table 1.4: This table shows the applicable standards and codes of the project	26
Table2.1: This table shows comparison between two design approaches	32
Table 3.1: This table shows comparison between three softwares	34
Table 3.2: This table shows comparison between three simulation softwares	35
Table 3.3: This table shows the softwares for coding	36
Table3.4: This table shows the hardware tools	37
Table 4.1: This table shows the identification of the optimal design approach	53
Table4.2: This table shows the performance evaluation of developed solution	54
Table 6.1: This table shows the SWOT analysis of developed solution	68
Table 7.1: Project Plan of FYDP(P)	71
Table 7.2: Project Plan of FYDP(D)	73
Table 7.3: Project Plan of FYDP(C)	74
Table 8.1: Budget of our prototype	77
Table 8.2: Budget of our real life project	78
Table 9.1: Table of the risk level of our project	82
Table 9.2: Table of the risk contingency plan of our project	83
Table 11.1: Table of the attributes of Complex Engineering Problems (EP)	88

Table11.2: Table of the attributes of Complex Engineering Activities (EA)	89
---	----

List of Figures

Figure-1.1 Pie-chart of the traffic congestion	16
Figure 1.2: Number of routes with permitted transit	18
Figure 1.3: Road accidents across the county in recent years and their reasons.	18
Figure-2.1- Block diagram of design approach 1	28
Figure-2.2- Flowchart of design approach 1	29
Figure-2.3- Block diagram of design approach 2	30
Figure-2.4- Flowchart of design approach 2	30
Figure-4.1- Schematic diagram of a smart bus monitoring system of design approach 1	40
Figure-4.2- People counting through IR sensor	41
Figure-4.3- Smoke is not detected through smoke sensor	42
Figure-4.4- Smoke is detected through smoke sensor	42
Figure-4.5- Object is detected through ultrasonic sensor	43
Figure-4.6- Accident is detected through vibration sensor	44
Figure-4.7- Accident is detected through a vibration sensor, and the location is sent to the administration through GPS and GSM modules.	44
Figure-4.8- Location tracking through GPS module and sending the information to the website	45
Figure-4.9- Schematic diagram of a smart bus monitoring system of design approach 2	46
Figure-4.10- Model trained by real data-sets	46
Figure-4.11- Graph of accuracy rate from real data-sets	47

Figure-4.12- People counting through image processing with open cv	47
Figure-4.13- Smoke is not detected through smoke sensor	48
Figure-4.14- Smoke is detected through smoke sensor	48
Figure-4.15- Object is detected through ultrasonic sensor	49
Figure-4.16- Accident is detected through vibration sensor	50
Figure-4.17- Accident is detected through a vibration sensor, and the location is sent to the administration through GPS and GSM modules.	50
Figure-4.18- Location tracking through GPS module and sending the information to the website	51
Figure-4.19- Online ticketing webpage	52
Figure-5.1- Outer body of the bus (side view)	58
Figure-5.2- Inner portion of the bus (Top view)	58
Figure-5.3- Name of the hardware components that are used to design the system.	59
Figure-5.4-Object Detection	60
Figure-5.5-Smoke Detection	60
Figure-5.6-Accident Detection and message sending with location to the administration	61
Figure-5.7- Location tracking through GPS module and sending the information to the website	62
Figure-5.8- Online ticketing web page	63
Figure-5.9- Model trained by real data-sets	63
Figure-5.10- Graph of accuracy rate from real data-sets	64
Figure-5.11- People counting through image processing with open cv	64

Figure-7.1- FYDP(P) project plan 70

Figure-7.2- FYDP(D) Project Plan 72

Figure-7.3- FYDP (C) Project Plan 73

Chapter 1: Introduction- [CO1, CO2, CO10]

1.1 Introduction

This chapter will include an explanation of the motivation for this project, the issues we are attempting to resolve, and the goals we have set for it.

1.1.1 Problem Statement

Traffic jams are a major issue in Bangladesh, particularly in urban areas due to the high population density. Despite advancements in transportation, buses remain the preferred mode of transportation for many people in this densely populated country. Unfortunately, waiting for transport vehicles with inconsistent arrival times is a common waste of people's time. This is particularly problematic for employees and students who depend on timely transportation. Selecting the appropriate vehicle from the many available options during peak hours can be challenging. Waiting on the road for transport vehicles can divert our attention from important daily responsibilities and cause congestion on the roadside, occasionally blocking routes. The streets of Dhaka are plagued with traffic congestion, and the city's infrastructure is deteriorating. This precarious condition largely results from insufficient road space, an unplanned road network configuration, and an antiquated traffic management system. People generally view bus transit operations, in particular, as the least desirable form of mobility choice available to them, particularly in terms of dependability, comfort, speed, and safety. Bus transit operations are part of the existing public transportation system. In an article published by the Daily Star in 2018, "According to a World Bank report, in the last 10 years, the average traffic speed in Dhaka has dropped from 21 kilometers per hour (mph) to 7 mph, and by 2035, the speed might drop to 4 kmph, which is slower than the walking speed. [1] In another article published by the Daily Star in 2019, To begins with, insufficient buses are serving all areas of the city.

Dhaka has a total of 366 bus routes, which may give the impression that the city is well-served by public transportation. However, the reality is that the buses are not very efficient in taking people to their desired destinations. Routes overlap unnecessarily for the sole purpose of profit maximization and operational efficiencies. [2] .Traffic congestion caused by buses can be a problem, especially during rush hour. The large number of buses on the road and their poor condition can lead to breakdowns and accidents, worsening the traffic situation. Additionally, the lack of adequate infrastructure like bus lanes, modern traffic lights, and effective policing can further exacerbate the problem.

Aside from this, women face many difficulties while getting into a bus or waiting for it. According to a new article published by the Daily Star on March 8, 2022. When discussing their experiences with public transportation, most women mentioned that moving buses pick up and drop off passengers on roads and that drivers tend to avoid picking up women during

peak commute times. [3]. For women, particularly younger women, who must frequently use public transportation because it is the more cost-effective option, traveling via public transportation has evolved into a living nightmare. This is especially true for younger women.[4] Based on our interviews with several stakeholders in the public transportation sector, including bus owner Tetulia Paribahan of Mashiur Rahman, bus driver Ariful, and bus helper Joy, we have identified several challenges faced by the industry. These challenges include unreliable passenger counting methods, safety concerns, incidents of harassment and theft, and difficulties establishing liability in the event of accidents. Bus owner Tetulia Paribahan highlighted that the current methods of passenger counting are often unreliable due to human error and potential bias, resulting in financial losses for bus owners. He believes that a monitoring system would provide accurate data and reduce the need for manual counting, resulting in greater efficiency and transparency. Tetulia Paribahan also mentioned that the monitoring system would improve safety by providing real-time information on the location and status of buses. This would allow passengers to plan their journeys better and reduce crowding at bus stops, which can lead to accidents and safety concerns. Bus driver Ariful and bus helper Rabbi noted that incidents of harassment and theft occur frequently on buses, which can damage the reputation of the industry. They believe that a monitoring system would deter criminal behavior and provide evidence in the event of incidents, helping to maintain safety and security on buses. Ariful also mentioned that accidents often occur due to the fault of other drivers or pedestrians, which can be difficult to prove without clear evidence. He believes that a monitoring system would provide objective accident data, helping establish liability and ensure fair justice. In light of these challenges, we propose the implementation of a monitoring system on buses in Bangladesh to address the issues mentioned above and improve the overall efficiency, safety, and security of public transportation. Another research paper published in December 2010 mentioned that about 16% of women face misbehavior from the driver/helper, 26% face overcrowding and no seat availability, and 7% face a long delay on the bus. [5]–[7].



Main Causes of Traffic Congestion in the City

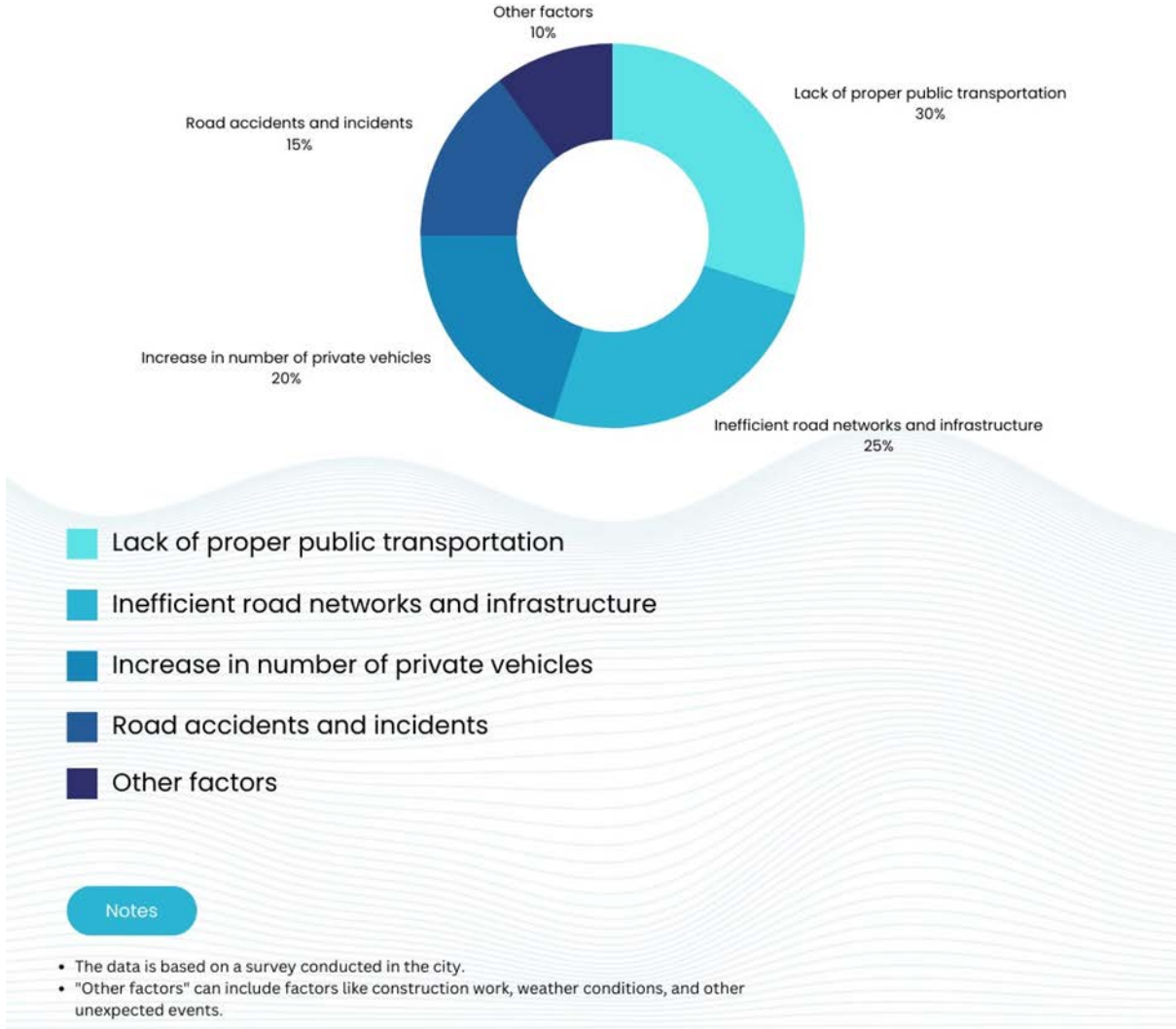

Figure-1.1 Pie-chart of the traffic congestion

To improve the transportation experience, a system is needed that alerts passengers when their selected vehicles are approaching, and provides details about the bus. Furthermore, this system must accurately communicate information regarding bus locations and arrival times to passengers, transit authorities, and other stakeholders.

1.1.2 Background Study

Since Bangladesh's independence in 1971, Dhaka has experienced unheard-of growth and development, rising from the status of a provincial capital to that of a nation. It is one of just seven cities worldwide where the urban population grew by more than 2.4% between 1975

and 2005. Nonetheless, Dhaka has managed to win a place on the list of most unlivable cities because of inadequate planning, particularly since 1990.

In Dhaka, the transportation system is becoming one of the main issues. The city is notorious for its extreme lack of traffic safety and never-ending traffic jams. Like every other developing-nation megacity, Dhaka's transportation issues are mostly caused by rapid expansion, great inequality, and poor income.

Despite a relatively low level of motorization, the streets of Dhaka suffer from severe traffic congestion and a decaying traffic system. The primary cause of this hazardous situation is mostly attributed to insufficient road capacity, unstructured road network layout, and outdated traffic control system. Out of all the available modes of public transportation, bus transit operations are widely regarded as the least favorable choice for mobility because to their lack of reliability, comfort, speed, and safety. The public transportation system in Dhaka is notorious for its congested buses, unpredictable timetables, and frequent traffic congestion, resulting in extended commuting durations for inhabitants. Although widely used and favored as a means of transportation, rickshaws contribute to the problem of traffic congestion.

Attempts have been undertaken to enhance the situation, such as the continuous construction of the metro rail network, with the objective of mitigating congestion and offering a more effective means of transportation. Nevertheless, the implementation of these projects requires a significant amount of time and may not have significantly altered the overall traffic situation at present.

Public transportation is the fundamental support system of any efficient society. Buses are essential for the mass transportation in this area. In April 2018, there were a total of 31,922 registered buses and 10,441 registered mini buses. It constitutes a mere 9.7% of the total transportation options. Simultaneously, it accommodates 77% of the entire population of this city [5]. Additionally, it accommodates a substantial share of individuals with moderate and low incomes.

Income Group	Population Of Income Group %	Transit Share
Low (<12,500)	48	41
Medium (12,500 - 55,000)	49	56
High (>55,000)	3	3
Total	100	100

Table 1.1: This table shows comparison of transit share for different income groups [5]. About 137 bus companies are operating in 140 routes. Almost 70% of the existing routes are about 11-30 km long. Most of these routes overlap with each other.

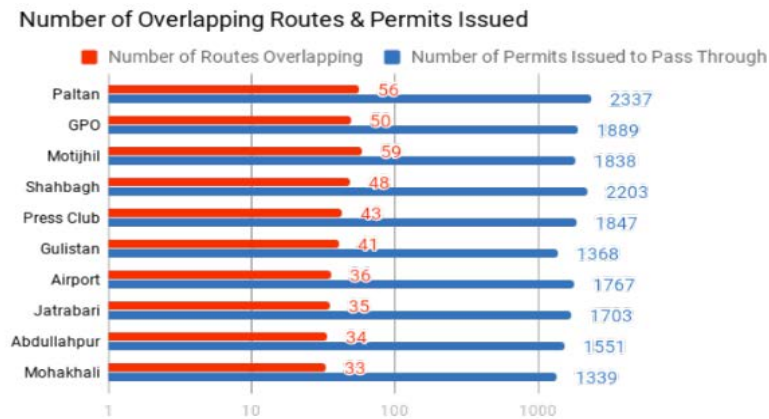

Figure 1.2: Number of routes with permitted transit [5]

Furthermore, due to the strong reliance of urban residents on buses, it is typical for buses to become excessively crowded with people. In severe cases, travelers are compelled to hang out of the door frames, posing substantial safety risks to both passengers and buses. Moreover, the inadequate and unsuitable facilities of the buses exacerbated the situation. Furthermore, as per the findings of Jatri Kalyan Samity, a staggering 87% of bus drivers in Dhaka city are implicated in charges of reckless driving and contravention of traffic regulations. However, in many instances, actions were unable to be pursued due to insufficient evidence and witnesses. The Bangladesh Road Transport Authority (BRTA) asserts that while there are more than 3.5 million automobiles registered, there are approximately 2.6 million drivers with valid licenses [2].

The Accident Research Institute (ARI) of the Bangladesh University of Engineering and Technology (BUET) has performed research. In Bangladesh, there has been a daily average of 20 fatalities and a total of 62,482 injuries resulting from accidents over the past three and a half years [1]. Figure 1.2 displays the frequency of traffic accidents in the county during the past few years, along with their main causes.

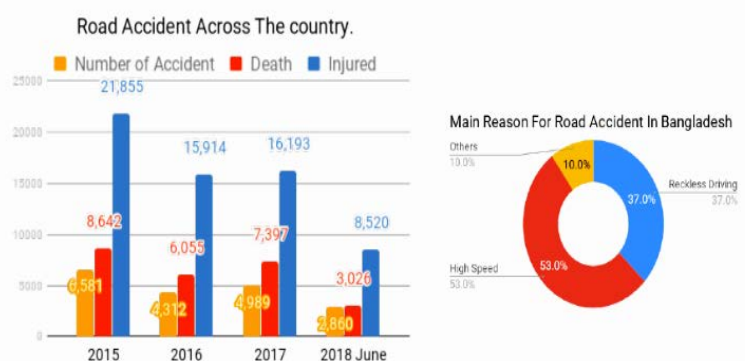

Figure 1.3: Road accidents across the county in recent years and their reasons [1].

Regrettably, the presence of multiple routes and bus companies is a challenge for users who find themselves in a situation where they must promptly determine the appropriate bus to board and the corresponding route that leads to their desired destination, not to mention the potential variations in fares. According to a survey by the World Bank, the residents of Dhaka lose over 3.2 million working hours on the road each day. Consequently, customers are now

required to invest effort in deciphering or recalling the sequence of bus routes. The waiting time at the bus stop and the time required to reach the destination cannot be accurately measured until we analyze the mobility data of buses. Moreover, it is imperative to consider the security measures for both the passengers and the vehicles.

As the saying goes, "time is money," and our goal is to save valuable time. Additionally, we prioritize safety for both passengers and transportation, as we believe in the importance of not learning safety through accidents. Our solution delivers the real time bus location, its arriving time and both the passengers and admin may know it from the website. Additionally, it offers data about bus congestion by utilizing image processing to count the number of people on board. In addition, the system guarantees passenger safety through the use of several sensors. Moreover, it offers the convenience of e-ticketing through its website, saving travelers significant time and effort.

1.1.3 Literature Gap

Public transportation safety, efficiency, and reliability are crucial in smart cities and sophisticated transportation systems. improve transportation, a system that warns passengers when their chosen vehicles are arriving and offers bus details is needed. This system must also accurately provide bus positions and arrival timings to passengers, transit authorities, and other stakeholders. This study designs and implements an intelligent bus monitoring system that uses cutting-edge technology to improve bus functionality. GPS-based position monitoring, picture processing for passenger counts, a website-based ticketing system, and safety sensors are included. We have ultrasonic object detectors, gas leak detectors, and accident detectors. The device immediately sends the bus administration the exact geographic coordinates in case of an accident. This intellectually challenging initiative aims to improve public transportation by providing current information and proactive safety measures.

1.1.4 Relevance to current and future Industry

The Jatri company was established in response to the difficult transportation conditions in Dhaka, which are marked by severe traffic congestion, insufficient public transit infrastructure, and a dearth of dependable information for commuters. In order to address these difficulties, a number of initiatives have been implemented over time to improve the overall commuting experience.

The Jatri app presumably emerged as a digital remedy to tackle these concerns, with the objective of furnishing passengers with up-to-the-minute data regarding bus routes, timetables, and estimated arrival times. The aim was to utilize technology to enhance the dependability and ease of utilizing public transport in Dhaka. The Jatri app, like other transport apps worldwide, was specifically developed to utilize GPS and data connectivity for the purpose of tracking buses, providing route information, and offering projected arrival times. In addition to this there is a smart transportation monitoring system existing in other

countries as well for example -The fare payment system for London's public transport utilizes the Oyster card, which is a contactless smart card. In addition, it enables commuters to utilize contactless payment methods such as credit/debit cards, mobile phones, and wearables immediately at the fare gates. This technology facilitates the collection of data regarding travel patterns, aids in the management of traffic congestion, and gives convenience to passengers. In South Korea, it uses the T-Money card, which is a contactless smart card, to facilitate smooth fare payments across different means of transit. In addition, they possess extensive bus information systems that provide real-time data on the arrival and departure times as well as the current positions of buses, thereby improving the convenience for commuters.

However, in Bangladesh, a major improvement to Dhaka's public transportation is the implementation of a smart bus monitoring system with innovative features including image processing, real-time seat availability, web-based e-ticketing, exact location tracking, and sensor-driven safety procedures. This system is specifically engineered to tackle the complex issues of the metropolis, providing customized solutions for its crowded and densely inhabited metropolitan environment. Consider the scenario of overcrowded vehicles and bustling streets in Dhaka. Real-time seat availability information assumes immense value in this particular context. By utilizing this information provided by the system, commuters can optimize their travel decisions, thereby increasing their level of comfort and overall satisfaction. Moreover, the incorporation of web-based electronic ticketing corresponds with the prevailing digital patterns in Dhaka, potentially optimizing the procedure for acquiring tickets and diminishing reliance on tangible transactions. The potential of the technology to adjust and enhance routes in accordance with the ever-changing traffic patterns of Dhaka is quite considerable. The ability to adjust can mitigate traffic congestion and improve the overall effectiveness of bus operations. Furthermore, by integrating sensor-activated safety mechanisms, passenger security is guaranteed, especially during instances of emergency or overcrowded buses; thus, this effectively tackles a pressing concern regarding the well-being of city commuters.

Anticipating the future, the integration of this sophisticated surveillance system signifies a critical financial commitment towards the betterment of Dhaka. The information obtained from this system may be applied to evidence-based urban planning, thereby contributing to the creation of transport networks that are both more sustainable and efficient. By supporting the city's ongoing urban development and enhancing the commuter experience, this comprehensive system not only improves the functionality of public transport but also considerably contributes to Dhaka's growth trajectory.

1.2 Objectives, Requirements, Specification and constant

1.2.1. Objectives

A bus tracking system is a complicated monitoring system because it must use a lot of different technologies, handle a lot of data, and give accurate and reliable information in real-time. The main objective of this project is:

1. To design and implement a monitoring system for Smart Public Transportation.
2. To provide real-time information on bus locations, schedules, and routes to transportation authorities, bus companies, and commuters.
3. To reduce the operating costs for bus companies by optimizing routes and schedules.

1.2.2 Functional and Nonfunctional Requirements

Here are the functional and non-functional requirements we need to design and implement a smart Transportation Monitoring System.

Functional	Requirements	Non-Functional Requirements
Capacity Management	Conveniently accommodates 30 passengers while avoiding overcapacity issues.	The system should be compatible with different types of buses and communication systems
Battery Longevity	Equip the system with a 10-hour battery life for a 10-time up-and-down route and employ energy-saving techniques.	The system must be easily maintainable and updated with minimal disruption.
Emergency Response	Integrate real-time location transmission and advanced collision detection to improve passenger safety.	The system should be secure and protect against unauthorized access to the data.
Real-time Monitoring:	Continuously track speed, battery, and route adherence in real time.	The system should be capable of managing a larger volume of data as more buses and passengers are added to it.
Distance Inside Transport	Collect and monitor data effectively within a distance of 30 feet inside the transport.	

User-Friendly Interface	Design an intuitive interface for easy passenger access to emergency features. Example -buzzer	
E-Ticketing	An App must be provided to purchase	

Table 1.2: This table shows the functional and nonfunctional requirements of the project

1.2.3 Specifications

The system specifications that we need for the design and implementation of the Smart Transportation Monitoring System are given below:

Sub-System	Components	Description
Vehicle Tracking System	GPS	<ul style="list-style-type: none"> • Chipset: Media Tek MT 3318,51 Channel • Baud Rate: 9600 bps (default) • Frequency: L1, 1575.42 MHz; C/A • Operating Temperature: -40 to 85 Degree Celsius
User Interface System	Camera	<ul style="list-style-type: none"> • Resolution: 1080p 30fps* AHD2.0 (16:9 aspect ratio) • Dimension: 53.55mm, 68.60mm,63.74mm • Operating Temperature: -20 to 50 Degree Celsius
	LCD	<ul style="list-style-type: none"> • 16 characters per line, 2 lines • Operates on a 5V supply voltage • Dimensions are typically around 80mm x 36mm x 12mm
	Buzzer	<ul style="list-style-type: none"> • Operating Voltage: 5V • Frequency: 2048 Hz • Body size: 12*9.8mm
Networking System	GSM	<ul style="list-style-type: none"> • Transfer Rate 85.6 kbps • Frequency: 850MHz, 900 MHz, 1800 MHz, 1900 MHz • Output Power: 1W,2W • Operating temperature: -30-80 Degree Celsius

Control System	Arduino Uno	<ul style="list-style-type: none"> • Operating Voltage: 5V • Digital I/O Pins: 14 (6 with PWM output) • Analog Input Pins: 6
Storage System	Cloud Server	<ul style="list-style-type: none"> • RAM (Memory): Provides a range of memory options, measured in gigabytes (GB), to support the needs of different workloads
Power System	Battery	<ul style="list-style-type: none"> • Lithium-ion rechargeable battery. • Maximum Continuous Discharge Current: Usually rated around 4.875 A. • Nominal Voltage: Typically 3.6V.
Safety System	Vibration Sensor	<ul style="list-style-type: none"> • Operating Voltage: 3.3V to 5V. • Operating Current: 15mA. • LM393 chip-on-board
	Gas Sensor	<ul style="list-style-type: none"> • Operating Voltage: +5V • can detect LPG, Alcohol, Propane, Hydrogen, Co and even Methane • Analog and Digital Output Voltage: 0V or 5V

Table 1.3: This table shows the specifications of the project

1.2.4 Technical and Non-technical consideration and constraints in design process

Technical Considerations:

- **Technology Selection:** The appropriate hardware and software components based on the monitoring requirements, scalability, compatibility, and reliability should be chosen.
- **Data Collection and Sensors:** The type of sensors needed for data collection, their accuracy, range, and how they integrate into the system should be determined.
- **Data Processing and Analytics:** Developing algorithms and methodologies for processing the collected data, analyzing it, and deriving meaningful insights or actions from it.
- **Connectivity:** Ensuring reliable and secure connectivity (Wi-Fi, cellular, etc.) between the sensors/devices and the central monitoring system.
- **Scalability and Flexibility:** Designing a system that can easily scale as requirements grow or change and that can adapt to new technologies or upgrades.

- Security and Privacy: Implementing robust security measures to protect the data, devices, and communications within the monitoring system from unauthorized access or breaches.

Non-technical Considerations:

- Budget and Resources: Assessing the available budget and resources for the design, development, and implementation of the system.
- Regulatory Compliance: Adhering to legal and regulatory standards regarding data privacy, security, and other relevant guidelines.
- User Interface and Experience: Designing an intuitive user interface for easy interaction and understanding of the monitoring system for end-users.
- Stakeholder Requirements: Understanding the needs and expectations of stakeholders and ensuring that the system aligns with their goals and objectives.
- Environmental Impact: Considering the environmental impact of the system components and their disposal at the end of their lifecycle.
- Maintenance and Support: Planning for ongoing maintenance, support, and updates to ensure the system's longevity and efficiency.

Constraints:

- Time Constraints: Meeting deadlines for the design, development, and deployment phases.
- Technical Expertise: Availability of skilled personnel or expertise in the specific technology or domain.
- Resource Limitations: Limited access to certain resources, such as hardware components or specific technologies.
- Compatibility Issues: Challenges in integrating different technologies or components due to compatibility issues.
- Budgetary Constraints: Limitations in funding that may restrict the choice of technology or scale of the project.

1.2.5 Applicable compliance, standards, and codes

Applicable Standards and Codes

Codes	Standards	Impact on Project
IEEE1609.2a-2017	This standard defines secure message formats and processing for use by wireless access devices in vehicular environments, including methods to secure wave management messages and methods to secure applicant messages.	In our project, we have to work with wireless communication. So we can learn about the standards from this code.
IEEE2301-2020	Advice is given for cloud computing ecosystem participants (cloud vendors, service providers, and users) on standards-based choices in areas such as application interfaces, portability interfaces, management interfaces, interoperability interfaces, file formats, and operation conventions. These choices are grouped into multiple logical profiles, which are organized to address different cloud roles.	As part of our design, we are going to use cloud servers for various purposes, so this application code will have to be followed.

IEEE802.11-2011	This code is part of the IEEE 802 set of local area network (LAN) technical standards, and specifies the set of media access control (MAC) and physical layer (PHY) protocols for implementing wireless local area network (WLAN) computer communication. The standard and amendments provide the basis for wireless network products using the WiFi brand and are the world's most widely used wireless computer networking standards.	This code helps us understand the usage of wireless network systems in an area.
-----------------	---	---

Bangladesh Cyber Security Act, 2018	<p>Section 30: This section requires service providers to take appropriate measures to protect the personal data of their customers.</p> <p>Section 32: This section requires service providers to notify the government and affected individuals in the event of a cyber-security incident.</p>	In our project, the public needs to share their information to get the bus service. As a result, it becomes a responsibility for the service providers to protect the information shared by customers, and in any unexpected circumstances, they have to give updates to the customers and law enforcement.
The Bangladesh Personal Data Protection Act, 2020	<p>Section 5: This section defines the principles of personal data protection, which include the requirement for obtaining consent from individuals before processing their personal data.</p> <p>Section 12: This section gives individuals the right to withdraw their consent at any time, and requires data controllers to respect this right.</p>	As people need to share their information, service providers have to get consent from the customer before providing service, and if any customer wants to clear their data, then service providers have to accept this. So, we need to maintain this act.

Table 1.4: This table shows the applicable standards and codes of the project

1.3 Systematic Overview/summary of the proposed project

The design and implementation of a smart transport monitoring system for passengers hold significant potential to revolutionize the way we perceive and engage with public transportation. This project harnesses the power of technical advances to create a more interconnected and responsive transport network. By integrating real-time data analytics, predictive modeling, and communication technologies, the system empowers passengers with accurate information on routes, schedules, and potential delays, ultimately enhancing their travel experience.

Moreover, the efficiency enhancement aspect of this project brings about a transformative shift in the way transportation systems are managed. The intelligent monitoring system optimizes routes, minimizes congestion, and streamlines operations, resulting in reduced travel times and increased overall efficiency. This not only benefits passengers but also contributes to a more sustainable urban environment by curbing traffic congestion and reducing carbon emissions.

Safety enhancement stands as a paramount outcome of this endeavor. By monitoring vehicle movements, identifying potential hazards, and promptly alerting both passengers and staff to

any anomalies, the system creates a safer travel environment. Passengers can embark on their journeys with a heightened sense of security, knowing that the system's vigilance mitigates risks and ensures their well-being throughout the commute.

In essence, this project's convergence of technical advances, efficiency enhancement, and safety enhancement presents a comprehensive solution to the challenges faced by modern transportation systems. As we look toward the future, this smart transport monitoring system serves as a testament to the positive impact that innovation can have on the quality of our daily lives, fostering a more connected, efficient, and secure transportation ecosystem for passengers and communities alike.

1.4 Conclusion

To conclude, the implementation of the intelligent bus monitoring system of our project represents a significant advancement in enhancing public transportation inside smart cities. Through the utilization of cutting-edge technology such as GPS monitoring and passenger-counting procedures, this system guarantees the provision of up-to-the-minute bus whereabouts and arrival information, thereby improving passenger convenience and optimizing transit operations. This approach not only emphasizes ease but also places a higher importance on safety. With its array of sensors designed to detect objects, gas leaks, and accidents, this system assures the implementation of proactive safety measures. For situations, quickly sharing accurate locations helps the bus administration to respond promptly, enhancing overall safety measures.

This effort epitomizes the core principles of smart cities by providing current information and actively improving safety in public transportation. The comprehensive strategy of this urban transit system establishes a novel benchmark, offering to revolutionize the experience of commuting by placing a high emphasis on passenger safety and system efficiency.

Chapter 2: Project Design Approach [CO5, CO6]

2.1 Introduction:

In the realm of academic inquiry, the choice of research methodology is pivotal. Researchers grapple with the decision of selecting an appropriate approach to investigate complex phenomena. While single-method studies have their merits, the integration of multiple approaches—often referred to as mixed methods—has gained prominence. In this discourse, we explore the rationale behind employing multiple methods, the advantages it offers, and its implications for enhancing our understanding of intricate engineering problems.

2.2 Identify multiple design approaches:

After reviewing and narrowing down our options, we finalized two approaches to work on and determined which was best. The two approaches are:

- i) GPS and IR Sensors Beneath Seats with Vending/Kiosk-Based Ticketing based Monitoring System.
- ii) GPS and ESP32-CAM with a ticketing based monitoring system.

2.3 Describe multiple design approach:

2.3.1 Overview of approach 1:

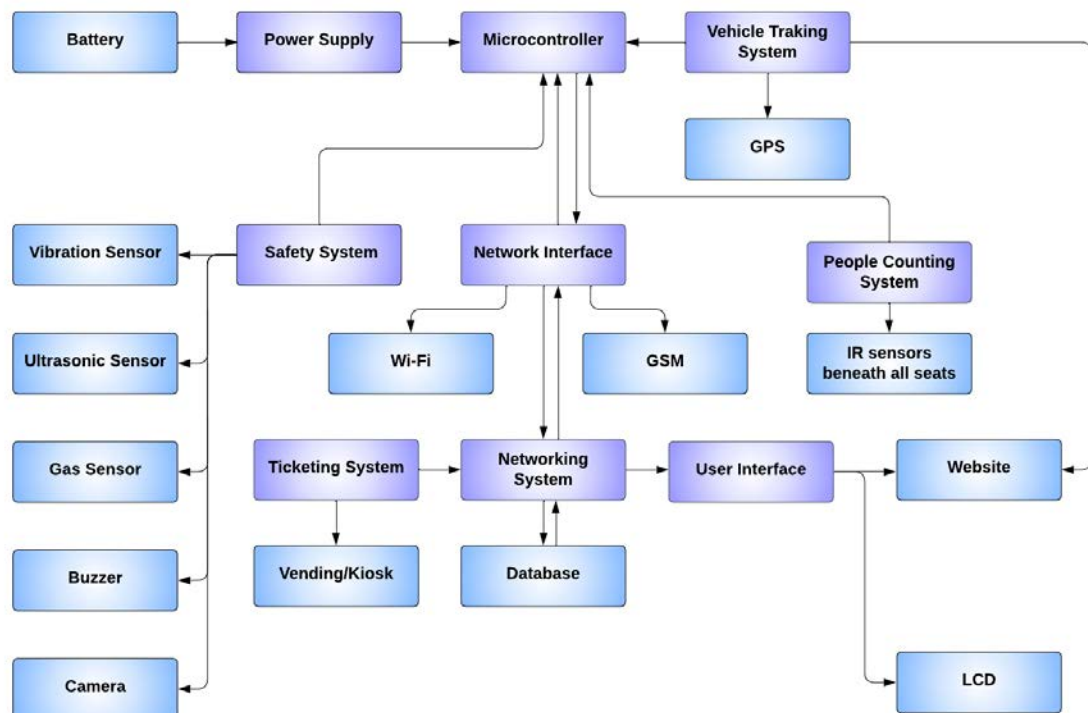

Figure-2.1- Block diagram of design approach 1

Methodology of approach 1:

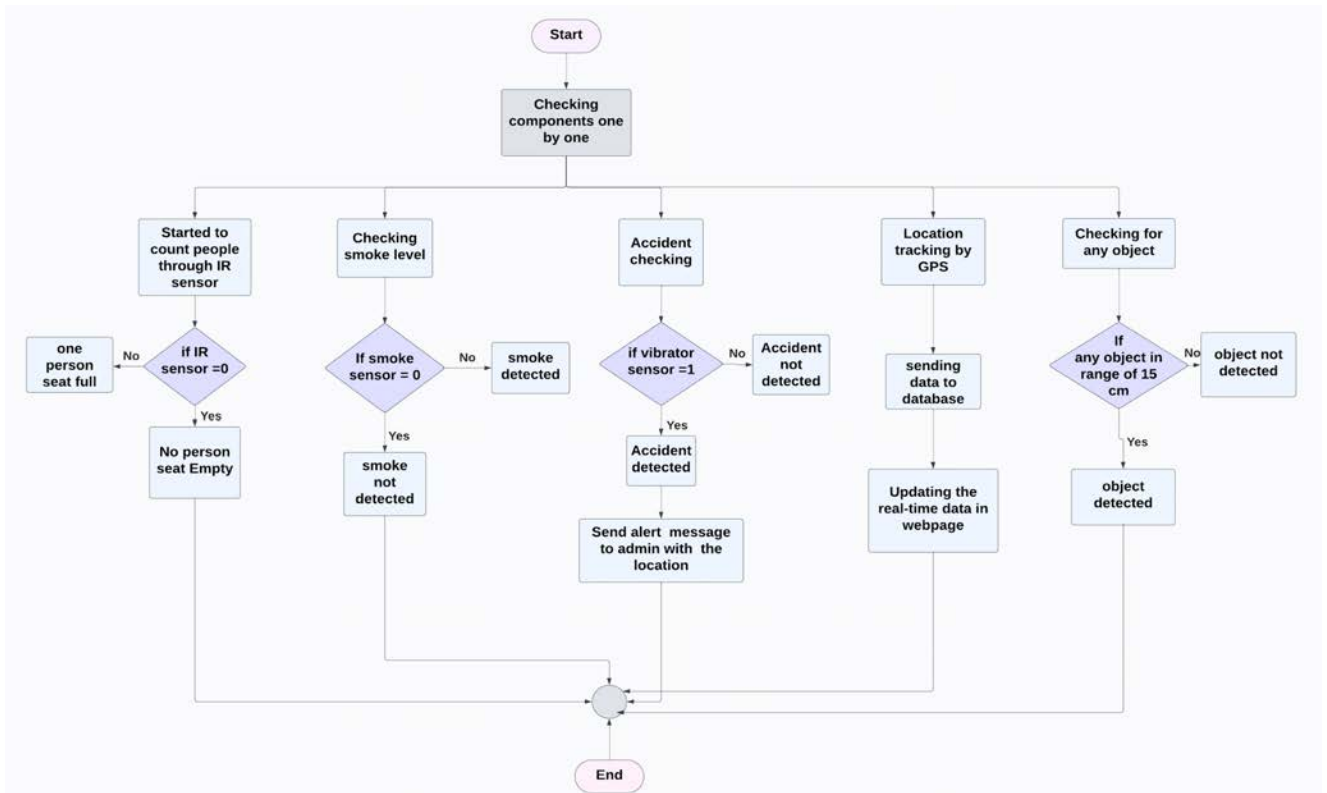

Figure-2.2- Flowchart of design approach 1

In the first design approach, a real-time GPS system is used to track the location of the bus. Additionally, IR sensors are installed beneath every seat to count the number of passengers onboard. The system also includes safety features such as ultrasonic sensors for object detection, gas sensors for gas detection, and vibration sensors for accident detection. In the event of an accident, the sensor will send a message with the accident location via GSM to the administration. Furthermore, a buzzer will sound whenever an accident, gas leak, or object is detected. The system also includes a camera to monitor the inside of the bus. In addition, this system has a website where people can view the bus's location and the number of passengers onboard. The system integrates with vending machines or kiosks for ticket purchases, providing physical ticketing options for passengers without the need for online transactions.

2.3.2 Overview of approach 2:

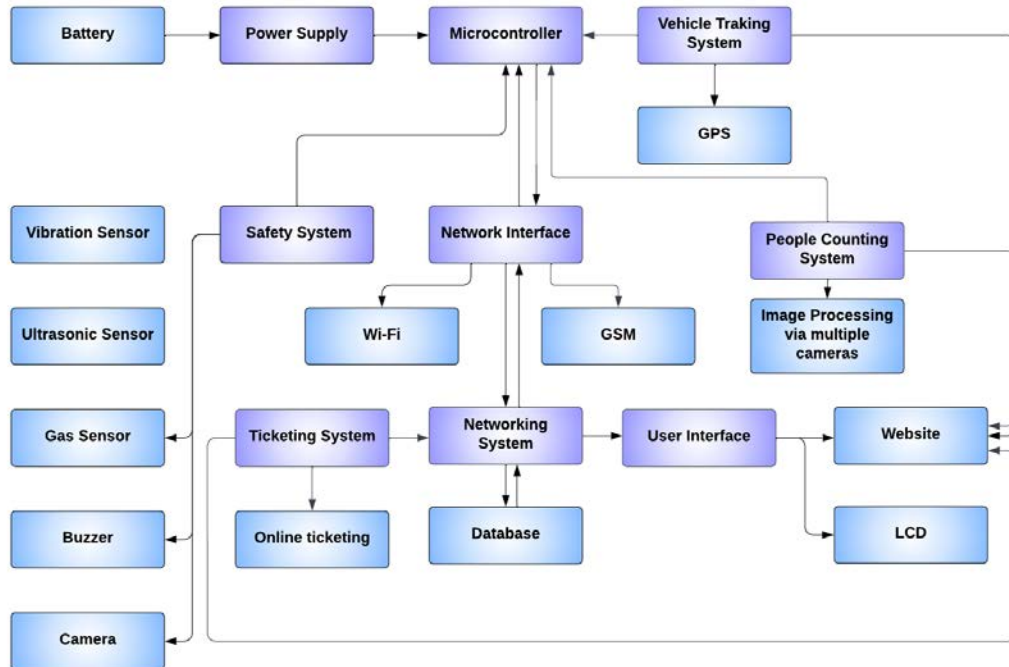

Figure-2.3- Block diagram of design approach 2

Methodology of design approach 2:

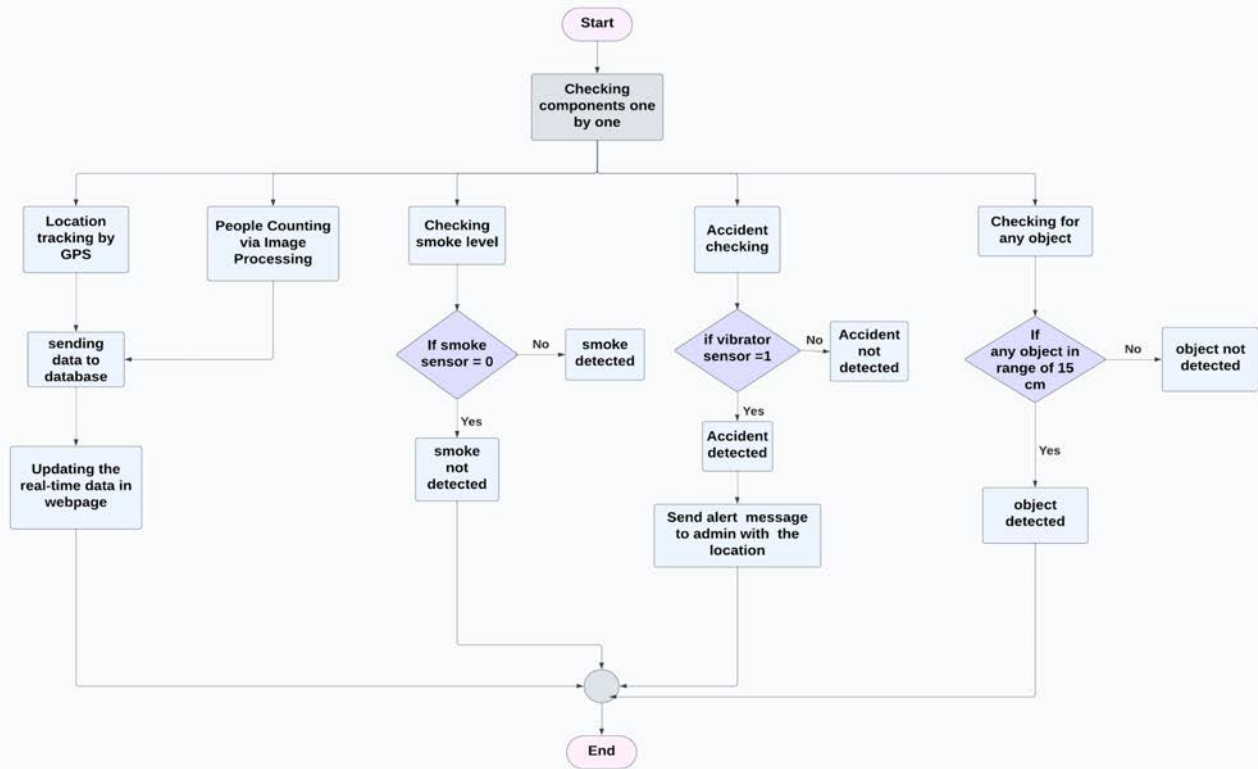

Figure-2.4- Flowchart of design approach 2

In the second design approach, a real-time GPS system is used to track the location of the bus. Multiple cameras are installed inside the bus to count the number of passengers via machine learning (image processing). The system also includes safety features such as ultrasonic sensors for object detection, gas sensors for gas detection, and vibration sensors for accident detection. In the event of an accident, the sensor will send a message with the accident location via GSM to the administration. Furthermore, a buzzer will sound whenever an accident, gas leak, or object is detected. The system also includes a camera to monitor the inside of the bus. In addition, this system has a website where people can view the bus's location and the number of passengers onboard. Moreover, the system integrates with an online ticketing platform, offering passengers the convenience of purchasing tickets remotely. Passengers can check the availability of seats and purchase tickets from the website as well.

2.4 Analysis of multiple design approaches:

Design Approach 1: IR Sensors Beneath Seats with Vending/Kiosk-Based Ticketing Monitoring System:

Design Approach 1 is a monitoring system that utilizes infrared (IR) sensors beneath seats to count the number of passengers. It also integrates with vending machines or kiosks for ticket purchases, providing physical ticketing options for passengers without the need for online

transactions. This approach accommodates vending/kiosk-based ticketing with simple and efficient seat occupancy data. Additionally, it incorporates ultrasonic, gas, and vibration sensors for object detection, gas detection, and accident detection, enhancing passenger safety with immediate alerts in case of potential hazards to the administration.

Advantages:

Design Approach 1 provides a practical alternative that lessens reliance on intricate web systems for passenger counting and ticketing. It also integrates with vending machines or kiosks to meet the needs of customers who prefer more conventional ways of purchasing tickets. Additionally, it counts the people in the car effectively by using infrared sensors under the seats.

Challenges:

Nevertheless, there are several drawbacks to Design Approach 1, such as the inability to count people who are merely seated, which might lead to erroneous passenger numbers if people are standing.

Design Approach 2: GPS and ESP32-CAM with an Online Ticketing based monitoring system:

Design Approach 2 is a transportation system that utilizes GPS technology for real-time tracking of the bus location and route. It also uses ESP32-CAM to capture images of the bus interior and employs image processing techniques for passenger counting. This approach integrates with an online ticketing platform, offering passengers the convenience of purchasing tickets remotely. It enables real-time updates on seat availability and schedules. Additionally, it incorporates ultrasonic, gas, and vibration sensors for accident detection. It enhances passenger safety with immediate alerts in case of potential hazards to the administration after accident detection.

Advantages:

In design approach 2, the implementation of real-time tracking can enable efficient route planning and scheduling, while online ticketing can enhance passenger convenience and reduce onboard transactions. Additionally, advanced safety features can contribute to a comprehensive passenger safety system.

Challenges:

It is important to note that seamless online ticketing and tracking may be dependent on a reliable internet connection, which could pose a potential challenge.

Comparative Analysis:

Basis	Approach 1	Approach 2
Real-time Location Tracking	Through GPS, the system can track the real-time location of the bus.	Through GPS, the system can track the real-time location of the bus.
People Counting	Done by IR sensors beneath the seats	Done by image processing via cameras
Ticketing System	Vending/Kiosk-Based Ticketing	Online Ticketing
Safety system	Have ultrasonic, gas, and vibration sensors for object, gas, and accident detection.	Have ultrasonic, gas, and vibration sensors for object, gas, and accident detection.
Complexity	Less	More
Expense	Less	More

Table 2.1: This table shows comparison between two design approaches

2.5 Conclusion:

The use of several methodologies, or mixed method approaches, to the study of complex engineering issues is a topic of much discussion in academia. These methods offer thorough explanations, improve understanding, and highlight different aspects of the phenomena, enabling researchers to extend their inquiry. In this instance, we think that the application of mixed method techniques really enhanced our results. In conclusion, a variety of criteria, including passenger preferences, budgetary constraints, and the degree of technical infrastructure present in the intended environment, will determine which of the two design approaches is best. A well-rounded solution may be achieved by combining the safety elements and ticketing techniques from the two strategies.

Chapter 3: Use of Modern Engineering and IT Tool. [CO9]

3.1 Introduction:

Advanced tools, including software, cloud computing, data analytics, and emerging technologies such as IoT and AI, have significantly transformed practices in modern engineering and IT. By transforming workflows across industries, this integration promotes innovation, efficiency, and precision. The collaboration among factors is crucial, not only for increased efficiency but also for groundbreaking innovations. An essential component of comprehending the dynamic engineering practices and the profound impact that IT will have on the future of the discipline is a firm grasp of these instruments within the academic community.

3.2 Select appropriate engineering and IT tools:

Our design process has incorporated modern engineering and IT tools, including software. We needed to choose modern engineering tools that met two requirements: hardware tools and software tools. To create the 3D design for our system, we utilized Fusion 360 3D Modeling Software. This application is widely recognized for its ability to produce both 2D and 3D models, and we found it to be a valuable tool for our project. Additionally, we used Proteus Design Suite and Arduino IDE software to simulate our system and create a two-dimensional circuit design. We used Google collab for object detection and firebase for location tracking and image processing through python to facilitate coding, while Visual Studio proved to be the ideal platform for website development.[8] For the design of our undertaking, an extensive array of engineering tools is necessary. Primarily, they can be categorized into four sections:

- Design Tools
- Simulation Tools
- Coding Tools
- Hardware Tools

3.3 Use of modern engineering and IT tools:

Design Tools:

We have compared the other 3D modeling software for our Design and chose Fusion 360 to build our design. Here is a comparative analysis of 3D modeling software.

Software	Library Materials	Template Management	Animation	Third-Party Integration	Collaborating of Tools
SKETCH-UP	×	✓	×	×	✓
FUSION 360	✓	✓	✓	✓	✓
BLENDER	×	✓	✓	×	×

Table 3.1: This table shows comparison between three 3D designing softwares
Result: FUSION360 offers better facilities in terms of 3D modeling and Design Software

Fusion 360 is a renowned and powerful 3D modeling software that provides a variety of advantages to users and industries. Consider using Fusion 360 for 3D modeling for the following primary reasons:

- Fusion 360 provides an integrated platform for 3D modeling, simulation, visualization, and collaboration, expediting the entire design process.
- It supports parametric modeling, which allows you to create designs with adjustable parameters, making it simpler to iterate and make modifications.
- It facilitates the creation of assemblies, allowing you to model complex systems and analyze the interaction between individual components.
- The cloud-based nature of Fusion 360 enables seamless collaboration among team members regardless of their physical location, thereby enhancing productivity and communication.

Simulation Tools

A comparative analysis of popular simulation software is shown below for our software.

Software	2D Features	Library Materials	Interact Simulation
PSPICE	✓	×	×
PROTEUS	✓	✓	✓
MATLAB	✓	×	×

Table 3.2: This table shows comparison between three simulation softwares

Result: PROTEUS is the best solution for Internal Circuit Simulation and Design

The simulation software features are similar, but Proteus stands out with its unique ability to interact with ongoing simulations using switches. We found Proteus to be the most user-friendly option for our simulation needs. It is a versatile tool used for designing and illustrating electronic circuits, including drawing schematics, PCB layouts, and code, as well as simulating the schematic. We have used Proteus to test the functionality of various sensors, such as water level sensors, timer sensors, and those used to measure water depth in a tank and automatically switch pumps.

Advantages of using PROTEUS for simulation of design:

- Uses switches to interact with an ongoing simulation.
- Extensive selection of components in its library.
- Create a schematic using thousands of components.
- Integrate with popular toolchains.

Coding Tools and Website Development

Software used for Web Development

Software	Application
Fire Base	Database
Visual Studio	Used to Develop the web

Table 3.2: This table shows the softwares for web development

We also used Visual Studio to code for the image processing from the footage received from the esp32-cam. We used Firebase as our database to store the data from the GPS and the no. of people, it also includes the ticket information. We used ReactJS, Python, and C and C++ languages in our work.

Software used for Coding

Software	Application
Google Collab	Image processing for real data set
Arduino IDE	To Code the Sensors and microprocessor

Table 3.3: This table shows the softwares for coding

In order to utilize Google Colab, real image datasets are uploaded either immediately from Google Drive or Google Colab. By utilizing libraries such as OpenCV or TensorFlow, it is possible to execute operations on images including resizing and filtering, train machine learning models when required, visualize outcomes, and effortlessly collaborate. In addition to this, we have used arduino to code the sensors that are connected to the microprocessor in the design.

Hardware Tools

We have used the following hardware applications for the implementation of our Design

Hardware	Application
ESP32-cam	Human Detection and monitoring
GPS	Location tracking
GSM	Sending Message
Arduino UNO	Microprocessor
Accelerometer	Accident Detection
Buzzer	To alert
LCD	For Display
Ultrasonic sensor	Object Detection
Smoke sensor	Smoke Detection
Motor Driver	To move the Bus
Relay	Safety Purpose
Battery	Power supply
Acrylic Body & 3D print	Structure of Body

Table 3.4: This table shows the hardware tools

Advantages of using the following components for hardware of design:

- **ESP32-cam** -The ESP32-CAM, which combines a built-in camera with the ESP32 microcontroller, facilitates object detection using image processing or machine learning methods. Through the utilization of picture capture and advanced processing capabilities, this system may effectively analyze visual data to identify certain patterns. Additionally, it can employ connected sensors such as ultrasonic or motion sensors to detect items in its immediate surroundings. Once detected, it initiates activities such as transmitting notifications by GSM, firing a buzzer, or presenting information on an LCD screen, thus expanding its capabilities beyond simple image capturing.
- **Global Positioning System(GPS)**-The Global Positioning System (GPS) functions by utilizing a constellation of satellites to allow GPS-enabled devices to accurately determine their precise geographical coordinates, encompassing latitude, longitude, and altitude. Through the process of triangulating signals from numerous satellites, these devices are able to precisely ascertain their locations, enabling the continuous monitoring and updating of position data in real-time. GPS is extensively utilised in navigation systems, logistics, and location-based services. It offers crucial features like route planning, asset tracking, and live monitoring, making it indispensable for accurate location tracking in various applications.

- **Global System for Mobile Communication(GSM)**-GSM (Global System for Mobile Communications) lets mobile devices send and receive text messages. GSM modules and SIM cards allow devices to encode, send, and receive messages over cellular networks. Data packets are delivered over the cellular network to the recipient's device, where they're decoded for display. GSM text messaging is essential for transmitting alerts, notifications, and crucial information in many applications, even in locations without internet availability.
- **Arduino UNO**- The Arduino UNO is a prominent microcontroller board that utilises the ATmega328P CPU. Due to its simplicity, adaptability, and ease of use, it functions as the central component in numerous DIY electronics projects. The UNO board is equipped with both digital and analogue input/output pins, which allow for seamless integration with sensors, actuators, and other electronic components.
- **Accelerometer**-Accelerometers perceive alterations in motion and acceleration. Accident detection systems perceive abrupt alterations, prompting safety reactions such as notifications or emergency mechanisms in automobiles or equipment, thereby aiding in the prevention of harm or destruction.
- **Buzzer**-A buzzer is a basic sound-emitting device that is used to notify or indicate consumers in a variety of applications. When triggered, it produces discernible tones or sounds, delivering prompt alerts or notifications in a variety of systems, including security alarms and electronic gadgets signaling occurrences.
- **Liquid -crystal Display (LCD)**-Liquid crystal displays (LCDs) utilize liquid crystals to visually present characters or pictures. These devices provide consumers with clear visual feedback by presenting data, system status, or sensor readings in many applications.
- **Ultrasonic Sensor**-Ultrasonic sensors measure distance using sound waves higher than the human ear can detect. The distance is calculated by measuring the time it takes ultrasonic pulses to bounce back after impacting an object at the speed of sound. These sensors are utilized for object detection, proximity sensing, and collision avoidance since they measure distance without touching the object.
- **Smoke Sensor**-Smoke sensors are devices that identify and quantify the levels of gasses in the atmosphere. They are frequently employed for safety purposes, such as detecting gas leaks or monitoring the air quality in different environments. They initiate alarms or execute actions when gas levels surpass acceptable thresholds.
- **Motor Driver**-A motor driver is an electronic device that regulates the movement of motors by controlling the flow of electrical current they receive. In the domain of buses or vehicles, a motor driver is responsible for supervising the functioning of motors that are responsible for movement, such as those that control the wheels or other mechanical components.
- **Relay Switch**-A motor driver is an electronic device that governs the motion of motors by managing the flow of electrical current they receive. Within the realm of buses or vehicles, a motor driver assumes the duty of overseeing the operation of motors that facilitate motion, such as those governing the wheels or other mechanical elements.
- **Battery** -Batteries function as mobile power sources, providing electrical energy to devices or systems. Within the realm of power supply, a 5V battery denotes a distinct

battery variant engineered to deliver a consistent voltage output of 5 volts. These batteries are capable of supplying power to a range of electronic components, microcontrollers, sensors, or modules that require a 5V power supply.

- **Acrylic Body & 3D print**-Acrylic and 3D printing are employed to fabricate durable and adaptable enclosures for electronic gadgets. Acrylic provides both durability and clarity, while 3D printing enables the creation of detailed and customised designs. Collectively, they construct long-lasting, safeguarding frameworks for electrical components.

Conclusion

In order to develop our project efficiently and successfully, we have selected the design, simulation, and coding tools based on the aforementioned criteria. During the process, we have also taken into account the potential for user-friendly operation, time limitations, and resource availability in order to tailor the project to meet the specified requirements. The selection of a design tool was mostly based on its user-friendliness. Certain tools provide user-friendly interfaces and intuitive capabilities that assist designers in swiftly and accurately creating models and simulations.

By prioritizing usability, designers may dedicate more time to constructing and evaluating projects without grappling with intricate tools and functionalities, resulting in improved project efficiency. Time limitations were another crucial factor taken into account when selecting an appropriate design tool.

The selected tools are well-suited for fast prototyping, enabling the team to efficiently construct and evaluate numerous iterations of the project. Meeting challenging project deadlines while upholding high standards of quality and accuracy is crucial.

Chapter 4: Optimization of Multiple Design and Finding the Optimal Solution. [CO7]

4.1 Introduction

To achieve the desired outcome of our project, we have proposed two design approaches. Both designs are capable of achieving the final result, but their working methodology is completely different from one another. In other words, their process of reaching the goal is different.

For the first design approach, we have explained the working methodology of people counting by IR sensor, location tracking by GPS, and ticketing system by vending machine. For the second approach, we have explained the working methodology of people counting by image processing, location tracking by GPS, and online ticketing. And there are some safety sensors for both the approaches as well. We have implemented simulations to obtain results for both approaches. Finally, by comparing those results, we obtained our optimal design.

4.2 Optimization of multiple design approach

4.2.1 Optimization of design approach 1

In proteus, this is the first design approach we have simulated.

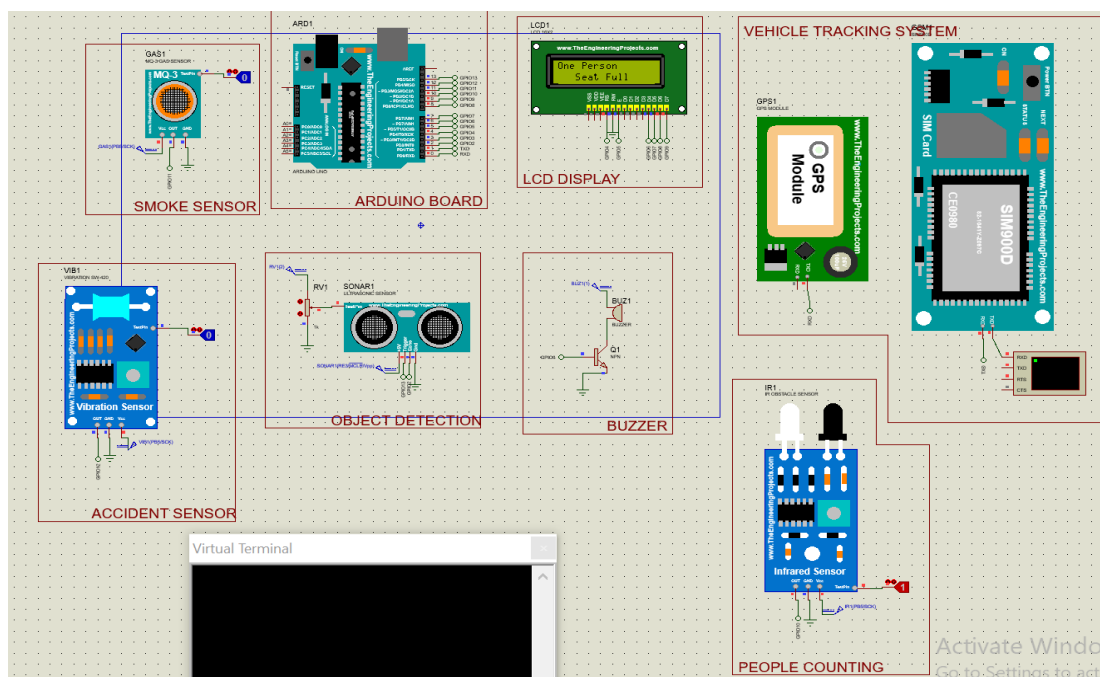

Figure-4.1- Schematic diagram of a smart bus monitoring system of design approach 1

Case-1: People Counting

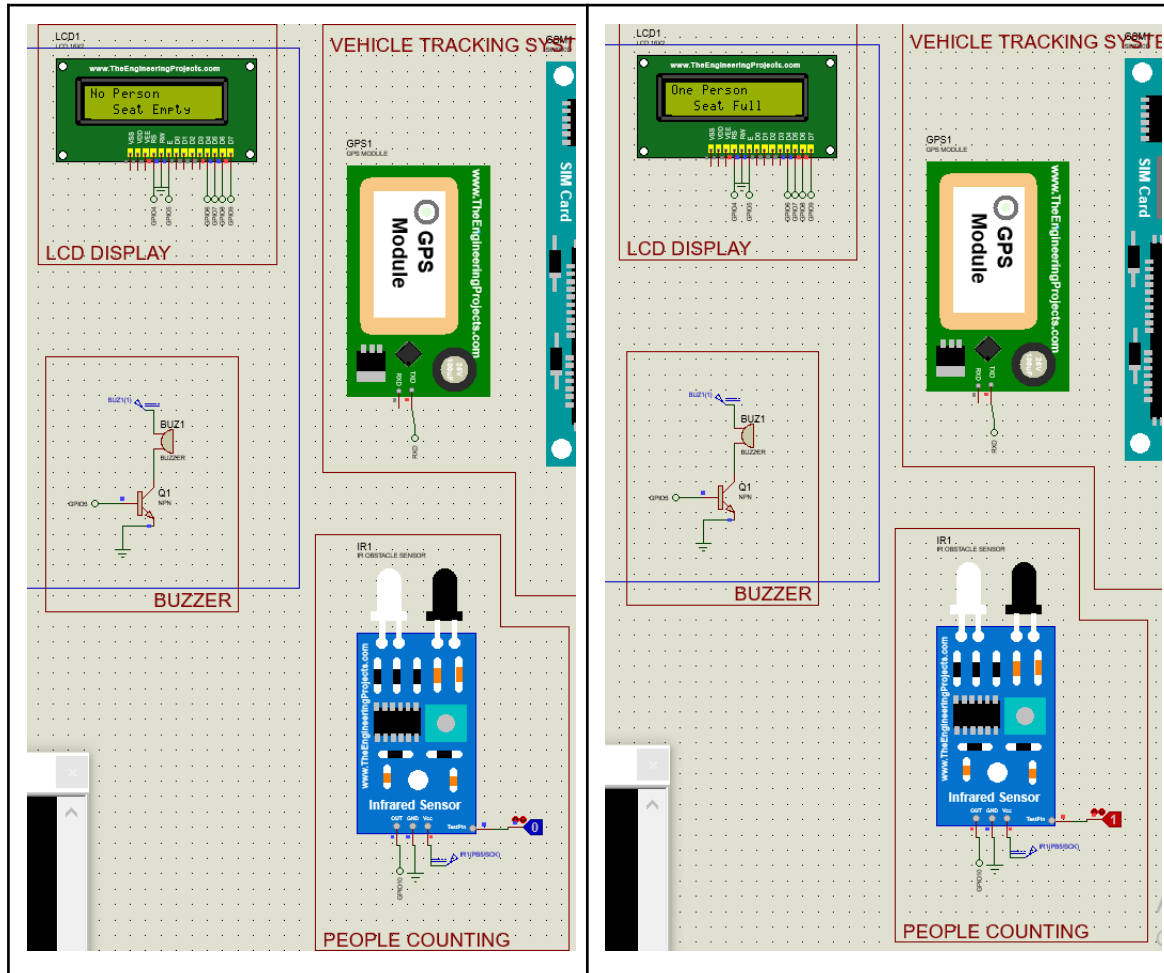

Figure-4.2- People counting through IR sensor

In a real-life scenario, there would be 30 IR sensors installed in a bus, one for each of the 30 seats. When a person sits down in a seat, the corresponding IR sensor will detect the person and count them. However, if a person is standing, the IR sensor will not be able to detect them. In the Proteus simulation, the people counting was demonstrated using only one IR sensor as an example. When the logic toggle of the IR sensor is 1, it indicates that the IR sensor has detected a person and the LCD will display “one person seat full”. Conversely, when the logic toggle of the IR sensor is 0, it indicates that the IR sensor could not detect a person and the LCD will display “no person seat empty”.

Case-2: Safety Systems:

i) Smoke detection by smoke sensor:

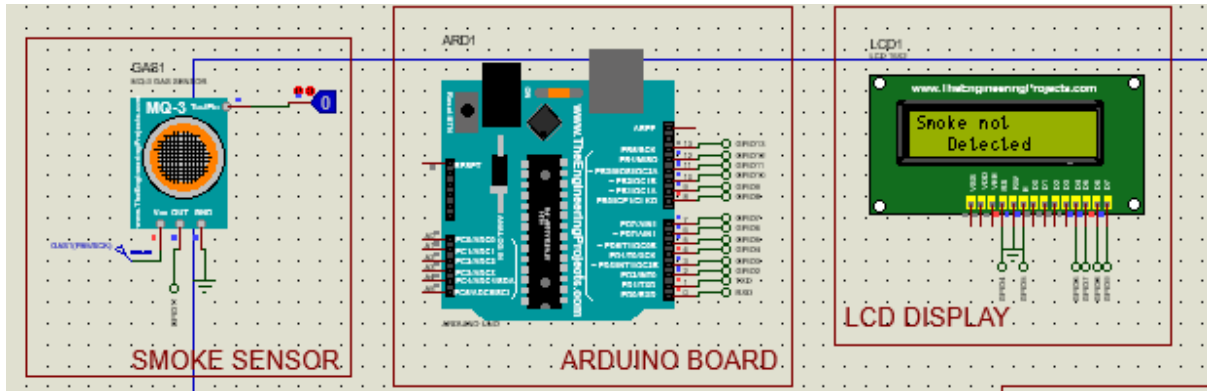

Figure-4.3- Smoke is not detected through smoke sensor

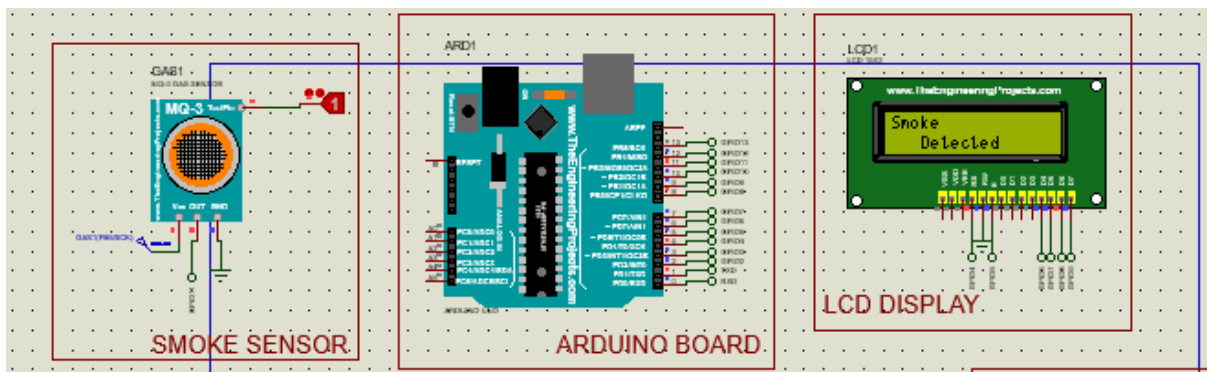

Figure-4.4- Smoke is detected through smoke sensor

The MQ-3 smoke sensor is activated by a logic toggle in the schematic, which sets the value to '1'. We have used this configuration to simulate the smoke sensor. And when the smoke is detected, the buzzer will turn on. And if the logic toggle is '0' then the LCD displays 'Smoke not Detected' and the buzzer will not turn on.

ii) Object detection by ultrasonic sensor:

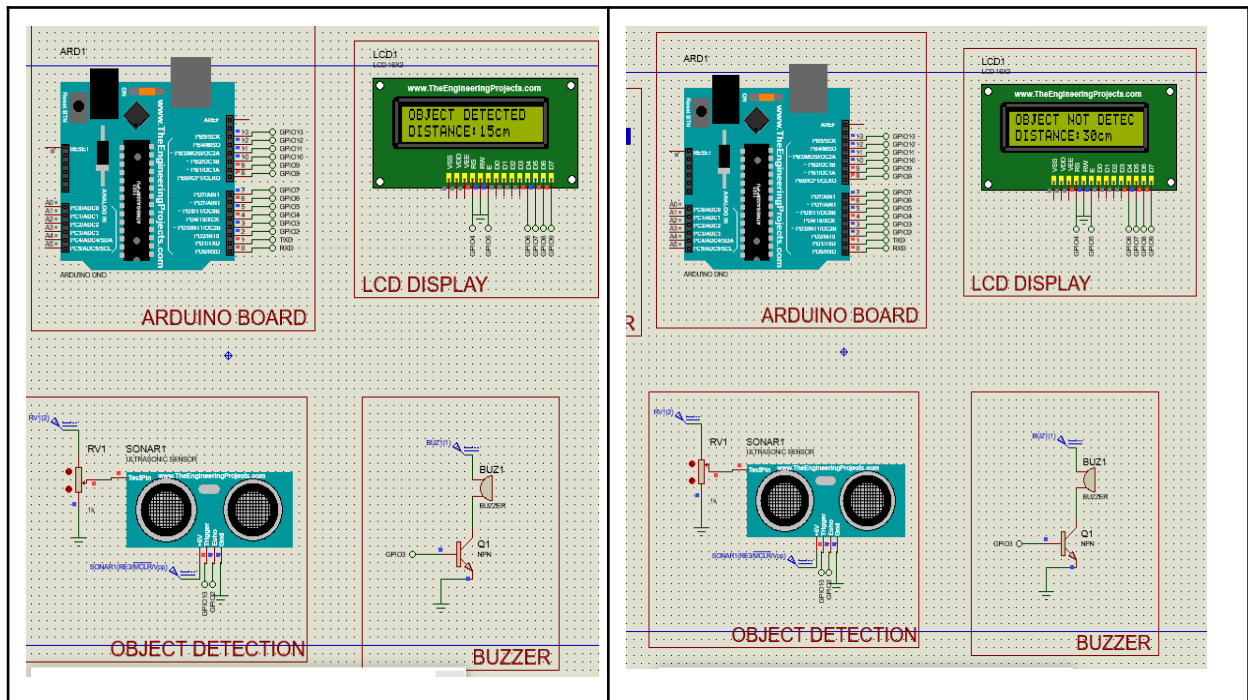

Figure-4.5- Object is detected through ultrasonic sensor

The ultrasonic sensor is utilized for the purpose of detecting objects. The distance measurement is simulated by a potentiometer that is connected to the Test pin of the ultrasonic sensor. The 16x2 LCD displays the calculated result from the schematic diagram of approach 1. The schematic design incorporates an ultrasonic sensor for object detection. The code has been programmed to transmit the result to an Arduino Uno, which subsequently displays the result on the LCD monitor. The ultrasonic sensor can detect objects within a range of 15 cm and the buzzer will turn on. However, objects will not be detected when the distance is more than 15 cm.

iii) Accident detection by vibration sensor:

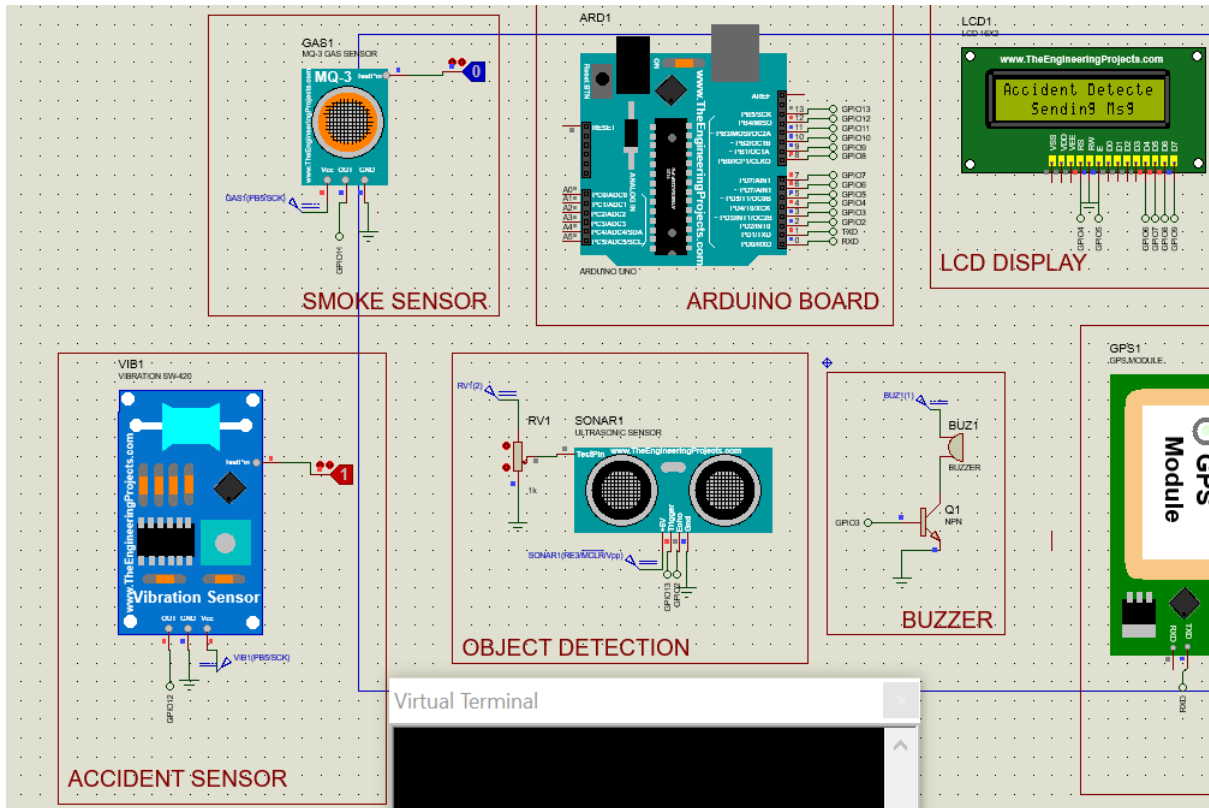

Figure-4.6- Accident is detected through vibration sensor

```

Virtual Terminal
AT+CMGF=1
OK
AT+CMGS="+8801712179068"

Accident Detected
please check location
Position:
lat:30.23663902
log:-97.82145690
Position:
lat:30.23664283
log:-97.82145690
    
```

Figure-4.7- Accident is detected through a vibration sensor, and the location is sent to the administration through GPS and GSM modules.

Here, the system detects accidents using a vibration sensor. The vibration sensor is triggered by a logic toggle. When the toggle is set to '1', the 16x2 LCD display shows 'accident detected'. And the buzzer will turn on. The location of the accident is sent to the administration through GPS and GSM modules. The LCD display also shows 'Accident Detected sending msg'. Additionally, the latitude and longitude of the accident spot are sent to the administration's number displayed in the virtual terminal.

Case-3: Location Tracking:

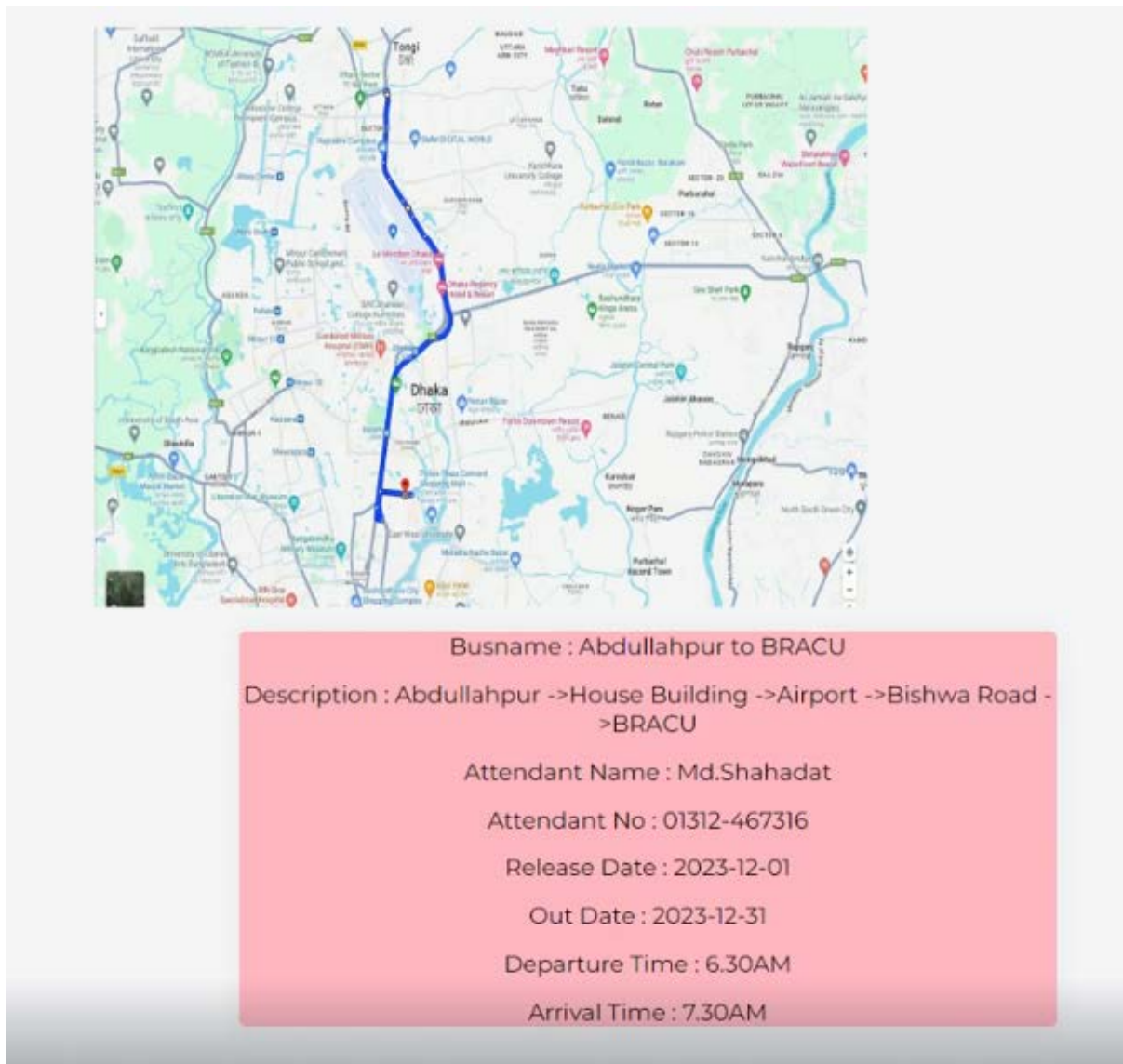

Figure-4.8- Location tracking through GPS module and sending the information to the website

A GPS module is installed in the bus to track its location and send this information to a website. The website displays the location of the bus on a Google map along with the arrival

and departure times, the name of the attendant, and their phone number. The map updates the location of the bus in real-time, every millisecond. And this location tracking and building website is done by firebase and visual studio. [8]

4.2.2 Optimization of design approach 2

In proteus, this is the second design approach we have simulated.

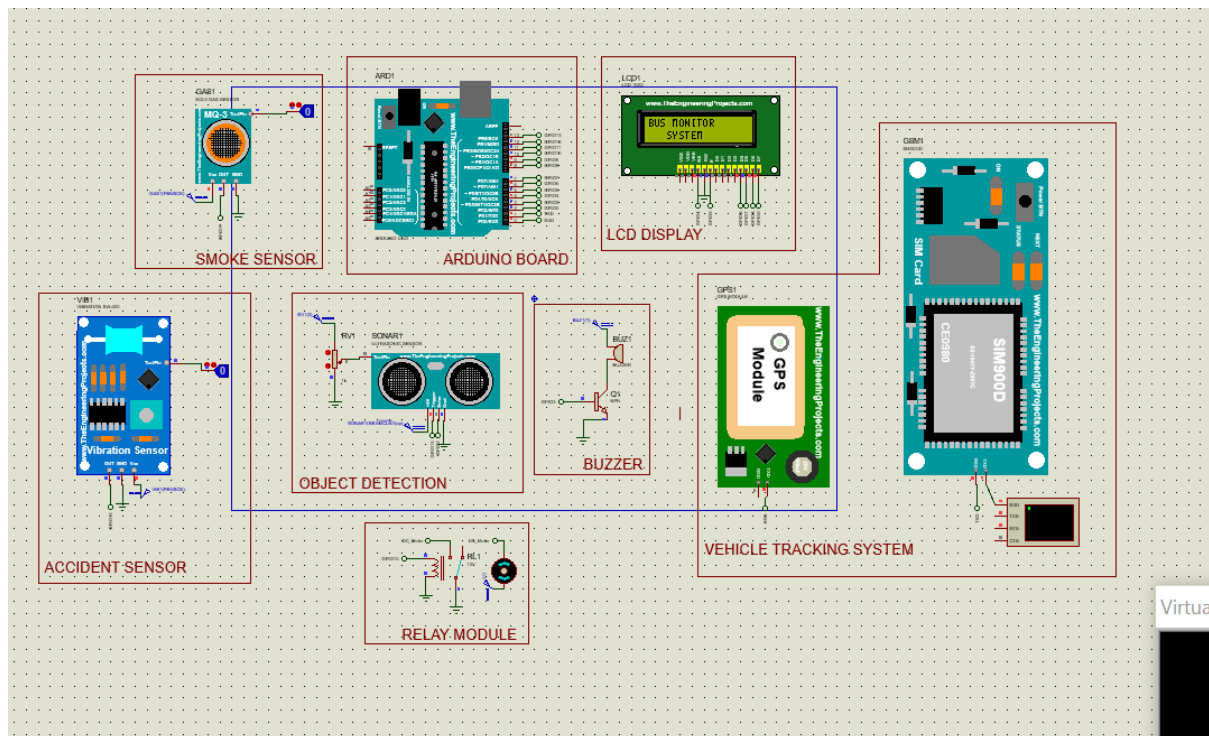

Figure-4.9- Schematic diagram of a smart bus monitoring system of design approach 2

Case-1: People Counting

i) With real datasets:



Figure-4.10- Model trained by real data-sets

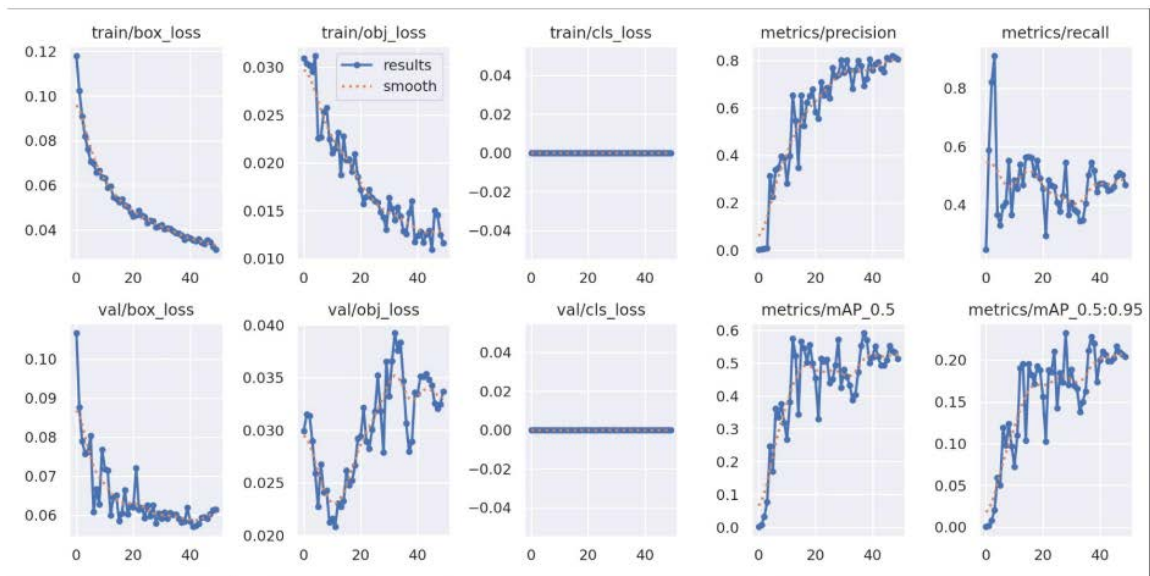

Figure-4.11- Graph of accuracy rate from real data-sets

This method uses machine learning (image processing) to count the number of people. To obtain the accuracy rate, we trained the model using 300 real data sets that we had gathered. The accuracy rate in this case is 57%, as indicated by the matrices/mAP_0.5' in the graph. But if we train the model on more datasets, the accuracy rate will rise.

ii) With an open CV in Firebase:

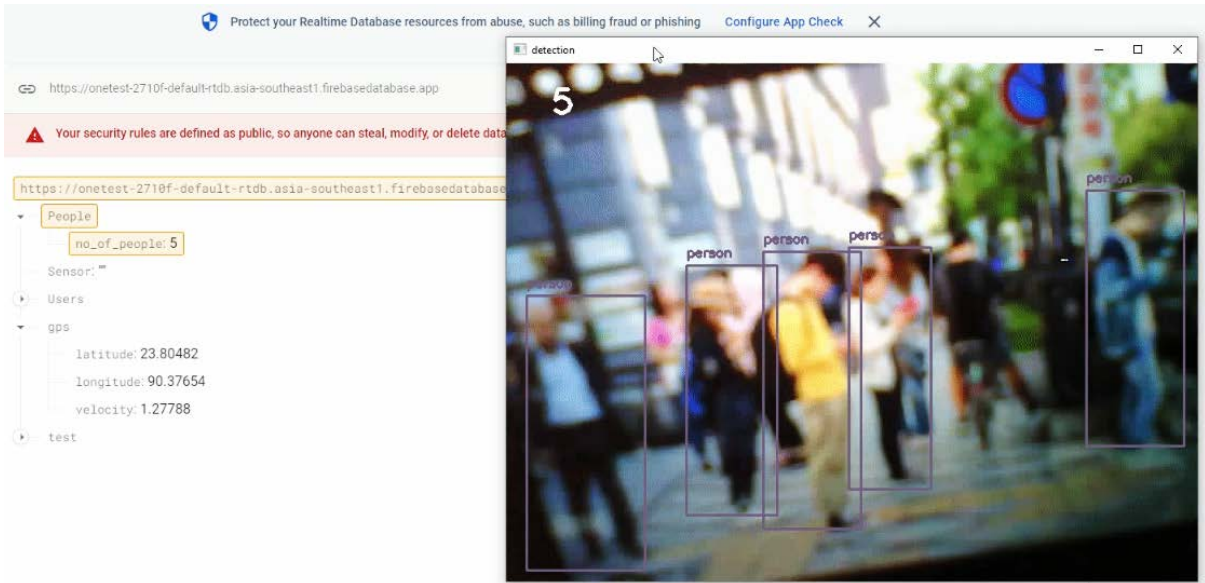

Figure-4.12- People counting through image processing with open cv

In this case, image processing is also used to count the number of people, although not using actual data sets. With the open CV, it is finished. Five persons are identified from this photograph, and the firebase displays the number of people.[9]

Case-2: Safety Systems:

i) Smoke detection by smoke sensor:

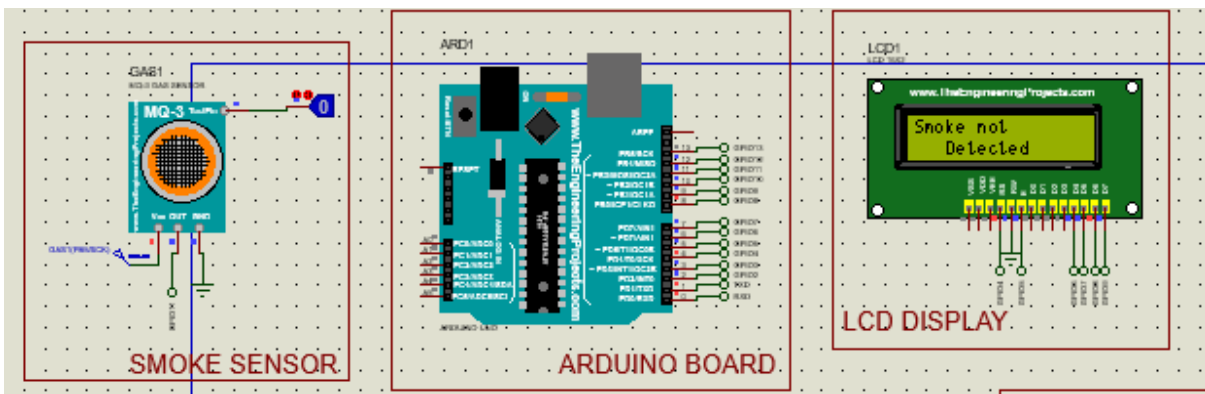

Figure-4.13- Smoke is not detected through smoke sensor

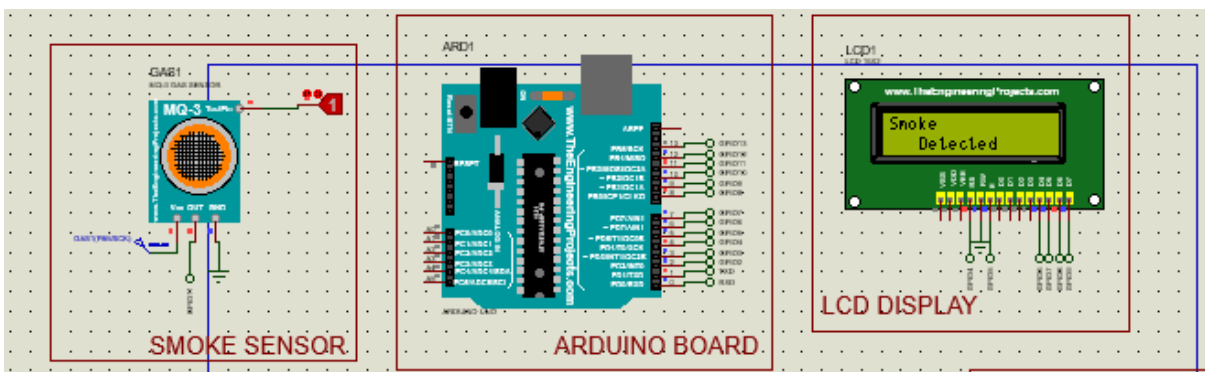

Figure-4.14- Smoke is detected through smoke sensor

The schematic shows a logic toggle that changes the value to '1' to activate the MQ-3 smoke sensor. This setup is what we've used to mimic the smoke sensor. Additionally, the buzzer will activate upon detection of smoke. However, the buzzer won't activate and the LCD will show 'Smoke not Detected' if the logic toggle is set to '0'.

ii) Object detection by ultrasonic sensor:

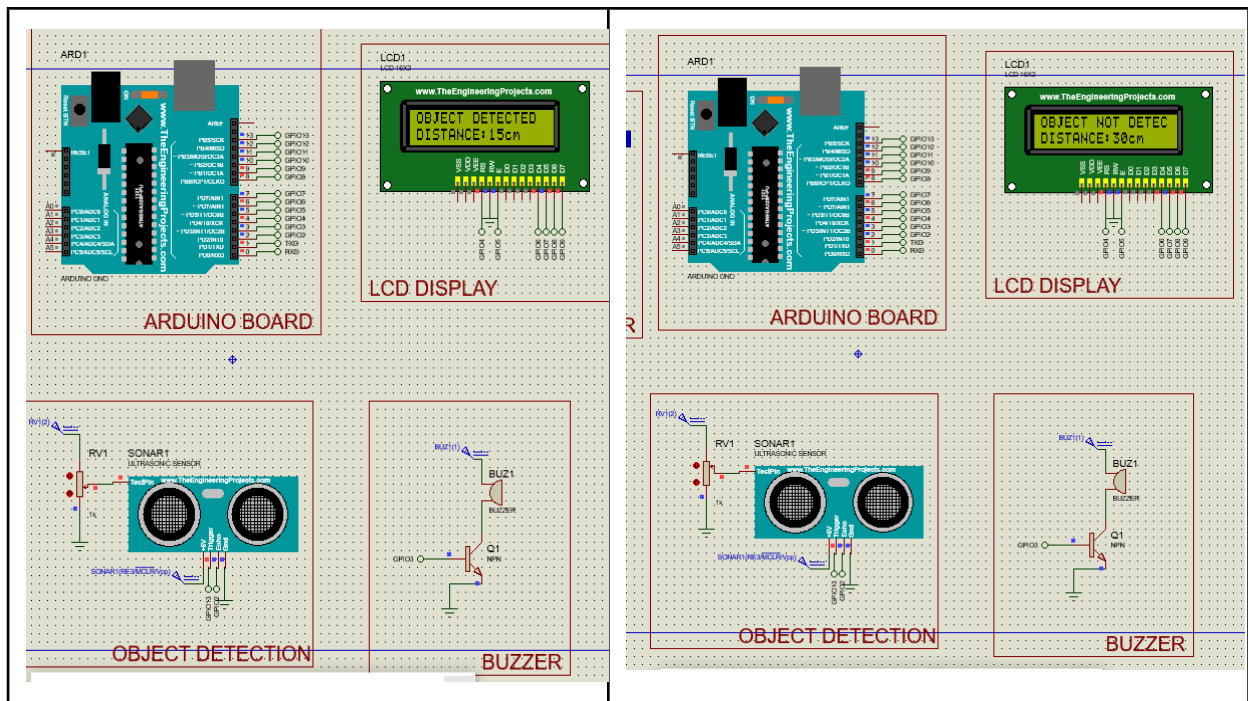

Figure-4.15- Object is detected through ultrasonic sensor

The objective of the ultrasonic sensor is object detection. A potentiometer linked to the ultrasonic sensor's Test pin simulates the measurement of distance. The computed outcome from method 2's schematic design is shown on the 16x2 LCD. An ultrasonic sensor is used in the schematic design to identify objects. The code is designed to send the outcome to an Arduino Uno, which then shows the outcome on the LCD panel. When an object is detected by the ultrasonic sensor within a 15 cm range, the buzzer will activate. However, ultrasonic sensors will not detect objects whose distance is greater than 15 cm.

iii) Accident detection by vibration sensor:

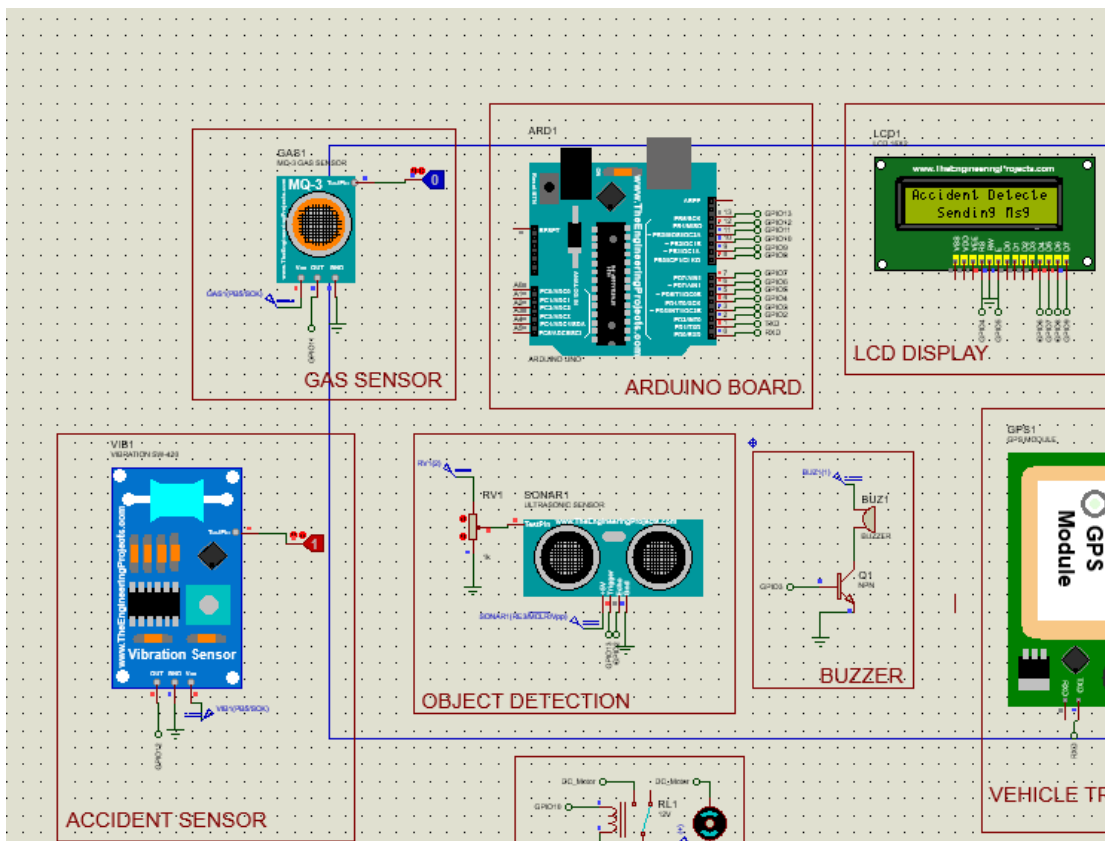
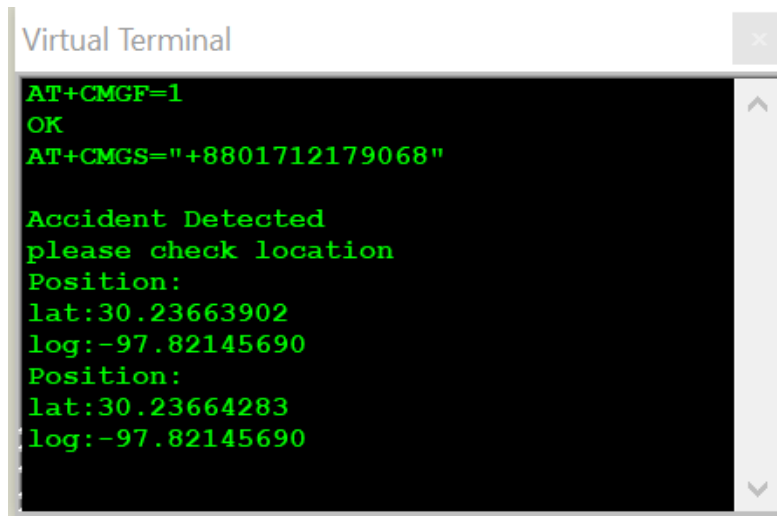

Figure-4.16- Accident is detected through vibration sensor



```
Virtual Terminal
AT+CMGF=1
OK
AT+CMGS="+8801712179068"

Accident Detected
please check location
Position:
lat:30.23663902
log:-97.82145690
Position:
lat:30.23664283
log:-97.82145690
```

Figure-4.17- Accident is detected through a vibration sensor, and the location is sent to the administration through GPS and GSM modules.

Here, a vibration sensor is used by the system to identify accidents. What activates the vibration sensor is a logic toggle. "Accident detected" appears on the 16x2 LCD display when the toggle is set to "1." The buzzer will then activate. GPS and GSM modules are used to transmit the accident's position to the administration. It also reads, "Accident Detected sending msg," on the LCD display. In addition, the administration number shown in the virtual terminal receives the latitude and longitude of the accident site.

Case-3: Location Tracking:

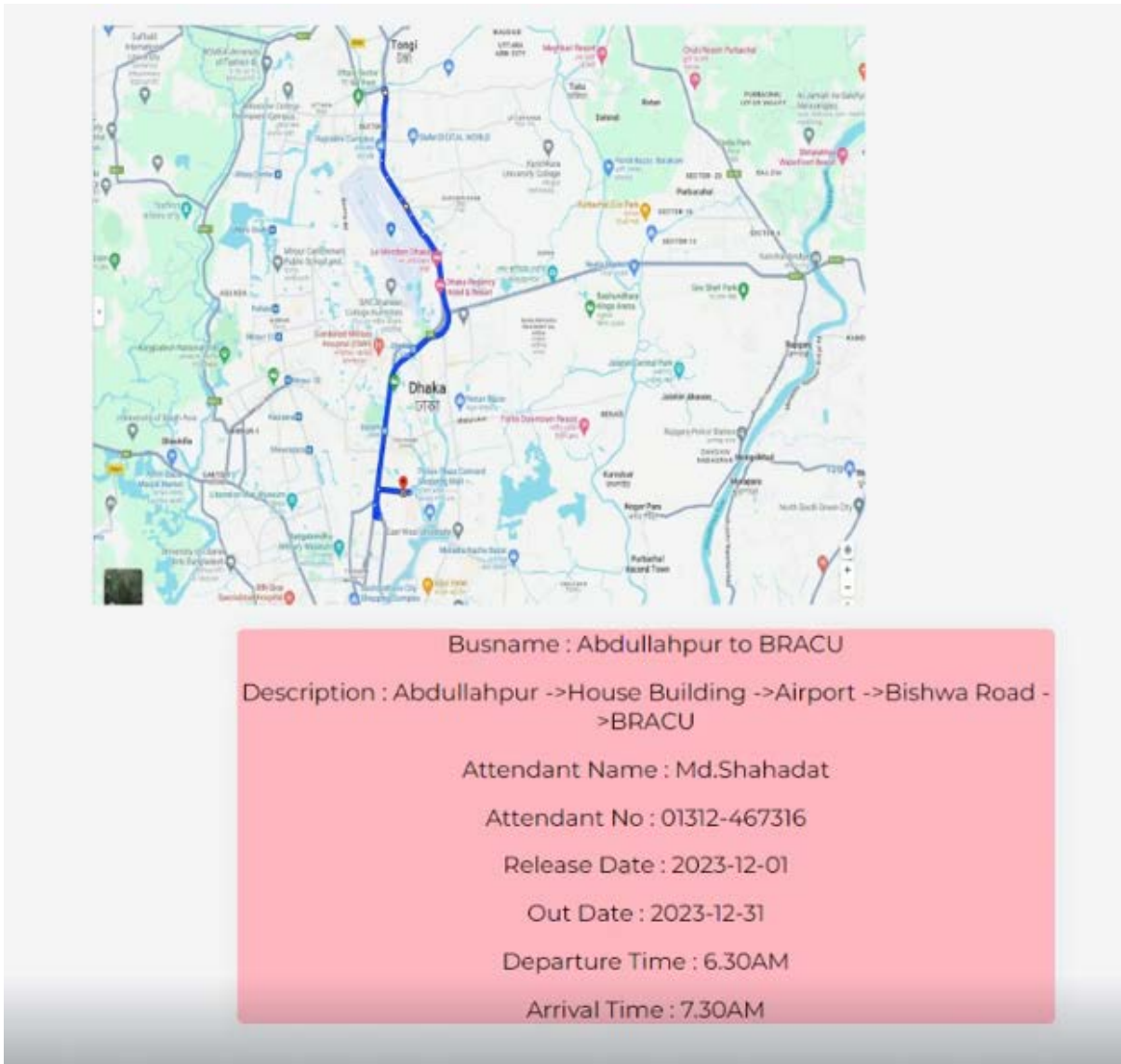

Figure-4.18- Location tracking through GPS module and sending the information to the website

The bus has a GPS module attached in order to track its whereabouts and transmit that data to a website. The website shows the bus's position on a Google map, along with the attendant's name, phone number, and the times of arrival and departure. Every millisecond, the bus's location is updated in real time on the map. And Visual Studio and Firebase are in charge of creating and tracking this location-based website. [10]

Case-4: Online Ticketing Website:

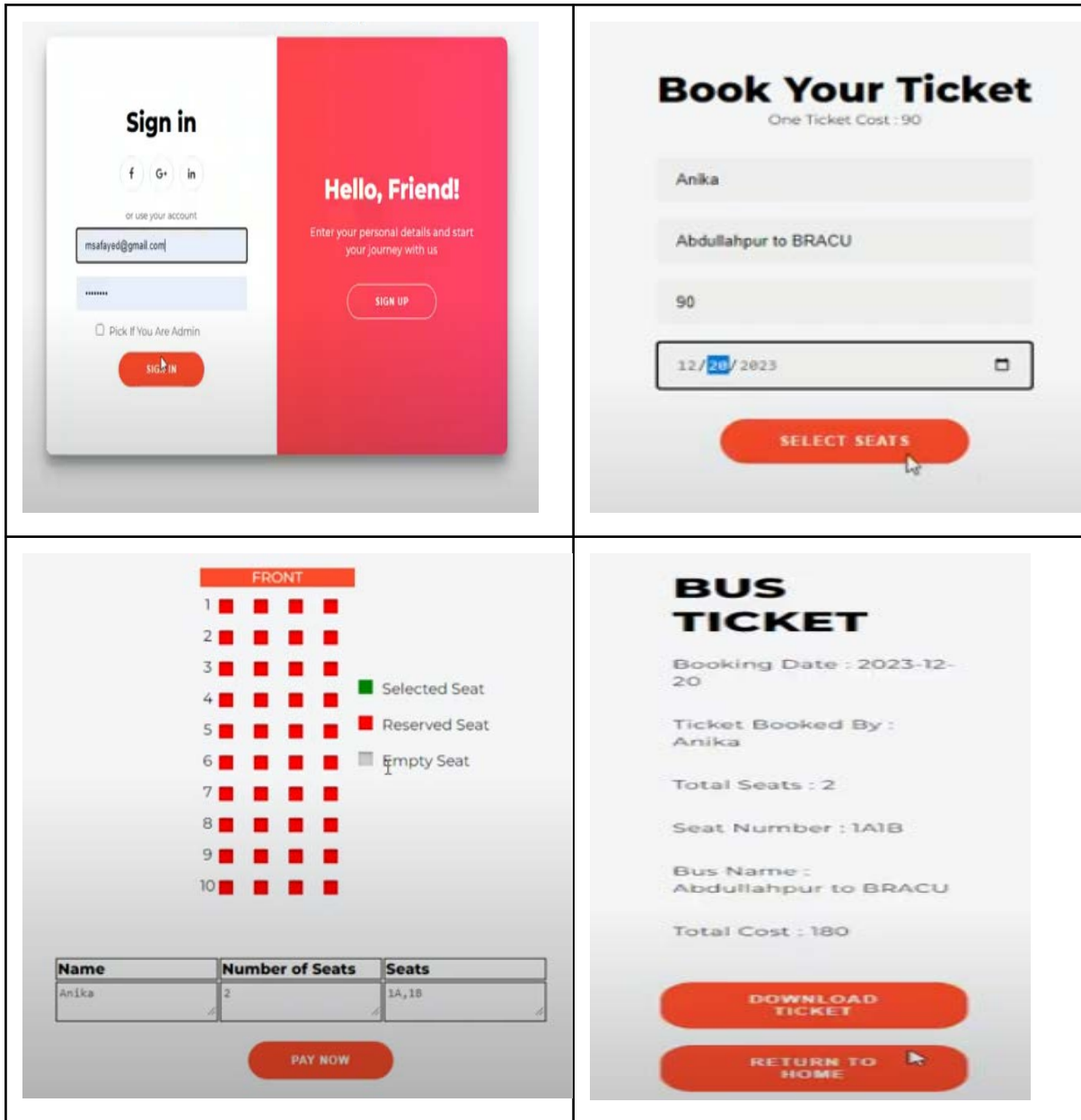

Figure-4.19- Online ticketing webpage

In this instance, ticket purchases can be made remotely. The status of seats may be determined using this ticketing web page. And people are free to reserve seats however they see fit.

4.3 Identify optimal design approach

Criteria	Design Approach 1	Design Approach 2	Prefered Design
Location Tracking	Yes	Yes	All
People Counting Accuracy	Less	More	Design Approach 2
Smoke Detection	Yes	Yes	All
Object Detection	Yes	Yes	All
Accident Detection	Yes	Yes	All
Ticketing System	Vending Machine	Online Ticketing	Design Approach 2
Portability	Less	More	Design Approach 2
Cost	Less	More	Design Approach 1
Dataset Collection	No	Yes	Design Approach 2
Alert System	Yes	Yes	All
Efficiency	Less	More	Design Approach 2

Table 4.1: This table shows the identification of the optimal design approach

Here, location tracking is a feature of both design methods. The bus's GPS module tracks its location and transmits that information to a database. The database then sends that information to a website where people can log in to view the bus's location on a Google map. As a result, huge amounts of time and energy can be saved. Therefore, both design methods meet this criterion.

According to this criterion, the IR sensor counts the number of persons in design approach 1. In reality, there will be IR sensors under each seat that will count the number of people in the bus. An infrared sensor counts a person as one when they take a seat. The IR sensor, however, is unable to keep track of the number of people standing inside the vehicle. This is a significant drawback. Furthermore, it will not count people if any of the IR sensors are broken, and replacing the sensor would be much more difficult. So, the accuracy level of people counting is low. Hence, design approach 1 is rather inconvenient. However, in design approach 2, many cameras are employed to count the number of persons using image processing. Here, we trained the model with datasets. In this case, the accuracy is way more than design approach 1. The second approach is therefore more suitable.

Both design approaches have safety systems in place. such as vibration, ultrasonic, and smoke sensors. The security of the bus and its occupants is guaranteed by these sensors. Because of this, both design approaches are suitable.

Design Approach 1 does not have the online ticketing feature. People have to purchase tickets through vending machines which is time consuming. However, design approach 2 has the

feature of online ticketing through website. People can purchase tickets remotely which makes the design approach 2 time-efficient.

For everyone, being able to easily log in remotely to a website and be aware of the bus position is a crucial function. Additionally, it enables users to check the status of their seats and reserve seats via the website's online ticketing feature. People save time and energy by doing this. Here, design approach 1's lack of online ticketing makes it less portable. Therefore, here, design method 2 is more effective.

The price is the main factor that buyers take into account while making a purchase. While design approach 1 could seem more cost effective, it requires more time and lacks critical precision. On the other hand, design approach 2 employs a range of techniques to guarantee that the demands of stakeholders are satisfied. Despite the higher expenditure, the product is now more time efficient and user-friendly because of the new features.

Both the design approaches have the alert system to the administration with the location of the accident spot when an accident is detected. So both the approaches here are appropriate.

4.4 Performance evaluation of developed solution

Requirements	Expected Outcome	Validation
Real-time location tracking	The bus's location needs to be updated every millisecond. Also, users should be able to view the current position of the bus on Google Maps via the website.	Validated
People counting	More precision should be used while counting people.	Validated
Safety System	Every sensor has to be operational, and if any item, smoke, accident, or object is detected, it ought to notify everyone by activating the buzzer.	Validated
Output display	Specific sensor information, such as smoke, object, and accident detection, should be shown on a 16x2 LCD display.	Validated
Notification System	A GSM module should send a notification containing the location of the accident spot to the administration if any accident is detected.	Validated
Ticketing system	People should purchase tickets remotely from the website	Validated
Real time monitoring of data	A web page is required to display the real time location, people count, and online ticketing.	Validated

Table 4.2: This table shows the performance evaluation of developed solution

4.5 Conclusion

In summary, after conducting an exhaustive assessment of two design approaches that took into account practical testing data and stakeholder feedback, we have determined that the second design approach we suggested not only fulfills but surpasses the intended goals.

Chapter 5: Completion of Final Design and Validation. [CO8]

5.1 Introduction

In order to fulfill our objectives as stated, our final design includes the execution of the features and functionality we have in mind for the project. It is essential that the project be carried out exactly as planned, with minimal to no deviations. In addition, the project's performance must be evaluated through the validation of output and the assessment of feedback.

5.2 Completion of final design

The process of examining and rating a project's design's viability, effectiveness, and efficiency prior to implementation is known as project design validation. Project design validation serves the function of verifying that the project is well-planned and that its goals can be met within the specified limits.

The following steps are usually involved in the validation process:

- i) Examine the project's goals: The project goals should be examined to make sure they meet the demands of the stakeholders and are SMART goals—specific, measurable, attainable, relevant, and time-bound.
- ii) Evaluate the project's viability: This step is necessary to make sure the project can really be completed within the allocated money, time, and resource restrictions. This might entail carrying out a feasibility assessment to determine any dangers, difficulties, and openings.
- iii) Assess the project design: The project design has to be assessed to make sure it has all the components that are required, including a well-defined scope, an actionable plan, and a suitable framework for monitoring and assessment.
- iv) Identify possible issues: Issues including dangers to the project's success, holes in the project design, or discrepancies with stakeholder expectations should all be noted and dealt with.
- v) Examine stakeholder input: To make sure the project design satisfies stakeholders' requirements and expectations, it is important to analyze stakeholder feedback.
- vi) Make revisions as needed: To guarantee the project's viability, efficacy, and efficiency, modifications to the design may be required based on the validation process.

To ensure that a project is well-planned and has the highest possibility of success, project design validation is, in general, a crucial stage. Through a thorough examination and revision of the project design, project managers may reduce risks, maximize resources, and increase the probability of accomplishing the project's goals.

5.2.1 Methodology:

We have taken the following actions in order to put the best design into practice:

i) Every part of the project is powered by two 3.7V, 1650 mAh Li-Ion batteries installed on a battery case

ii) Four HC-SR04 ultrasonic sonar sensors are being used to identify objects. The Arduino Uno's digital pins 4 to 11 are used to connect these sensors.

iii) The MQ-3 smoke sensor is used to detect smoke. The Arduino Uno's A0 pin is used to read analog data that is straight from the sensor. Additionally, the Arduino Uno's A1 pin contains a buzzer.

iv) The system uses an Ublox Neo 6m to get GPS information from satellites, including latitude and longitude. The best time to test it is when the sky is clear. Additionally, we must install a SIM card to use the GSM module to send notifications for the accidents to the phone. And batteries are required to power the GSM module. The Arduino UNO's digital pins 0 through 3 are used by this GPS and GSM module.

v) We are employing a 1.3 inch 12C OLED display module that is installed within the bus to display data from the sensors. Analog pins A4 and A5 on the Arduino Uno are linked to the SDA and SCL of the I2C.

vi) An accelerometer is employed in accident detection. Although the MPU-6050 sensor (accelerometer) and the OLED display in this case utilize separate I2C addresses, we may connect them to the same I2C bus (same pins on the Arduino board). In other words, just like an OLED display, the accelerometer's SDA and SCL are linked to the Arduino Uno's analog pins A4 and A5.

vii) Pins 14 and 15 of second ESP32 are connected to GPS pins Tx and Rx. And pin 4 is used to control the lights with the help of a slider on the web server. The esp33cam is further connected with the GPS to send the longitude, latitude and velocity information to the firebase database. It also sends the live video footage to a server from where we can fetch the video footage and use image processing in a server side pc to count the number of people and send that information to the firebase database.

viii) And a motor driver connected to ESP32 cam moves the bus. Pins are pinEnA, pinIn1, and pinIN2 are connected with pins (2,12,13) of ESP32 for right motor pins and for left motor pins are pinEnB, pinIn1, and pinIN2 which are connected to the pins (2,1,3) of the ESP32. And a relay is connected to the arduino for safety purposes.

5.2.2 Developed Prototype:



Figure-5.1- Outer body of the bus (side view)

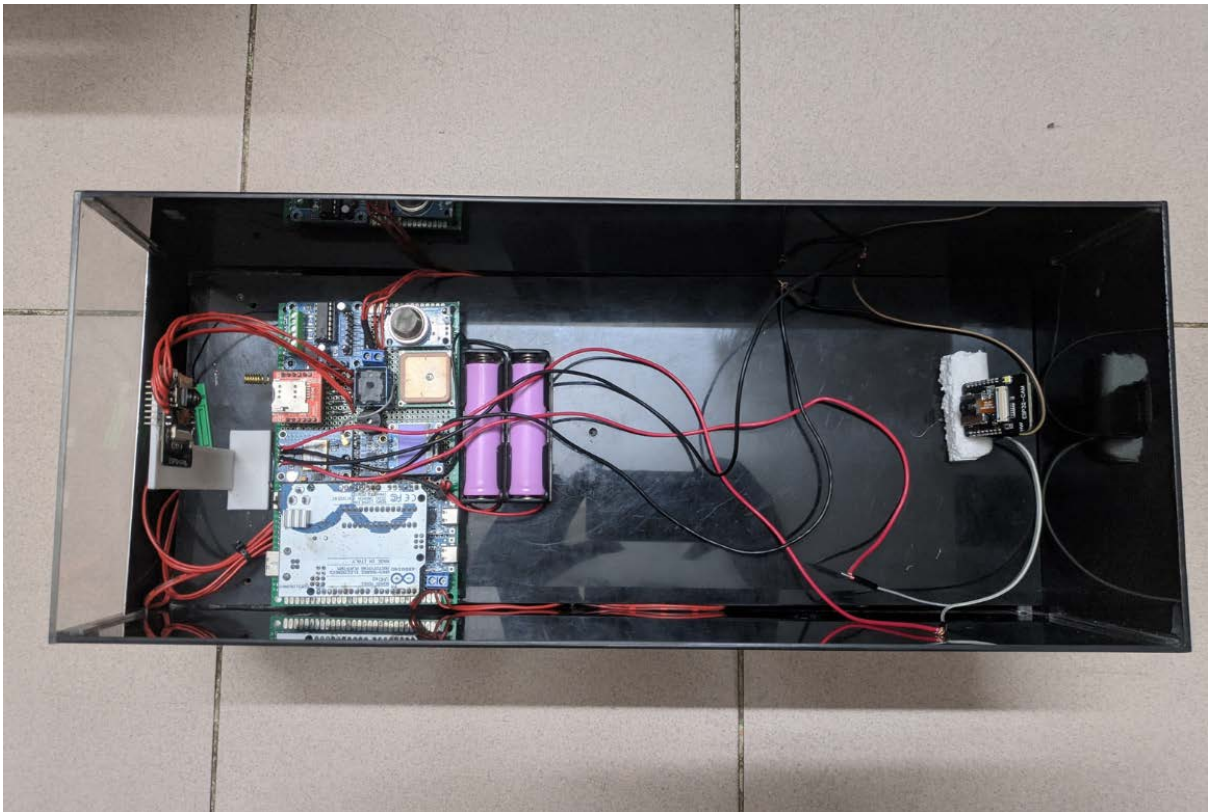

Figure-5.2- Inner portion of the bus (Top view)

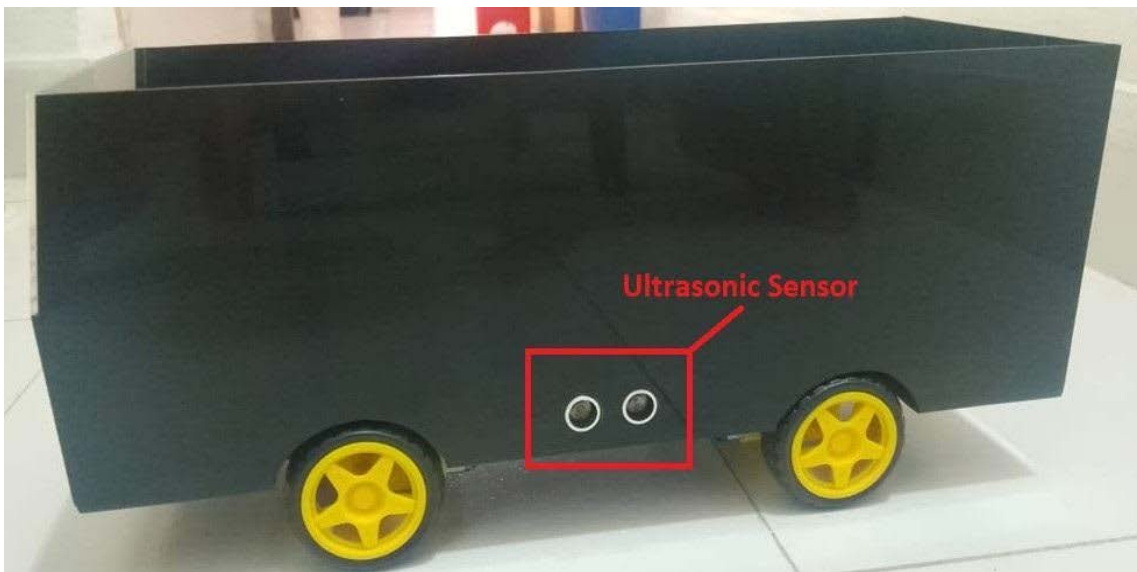
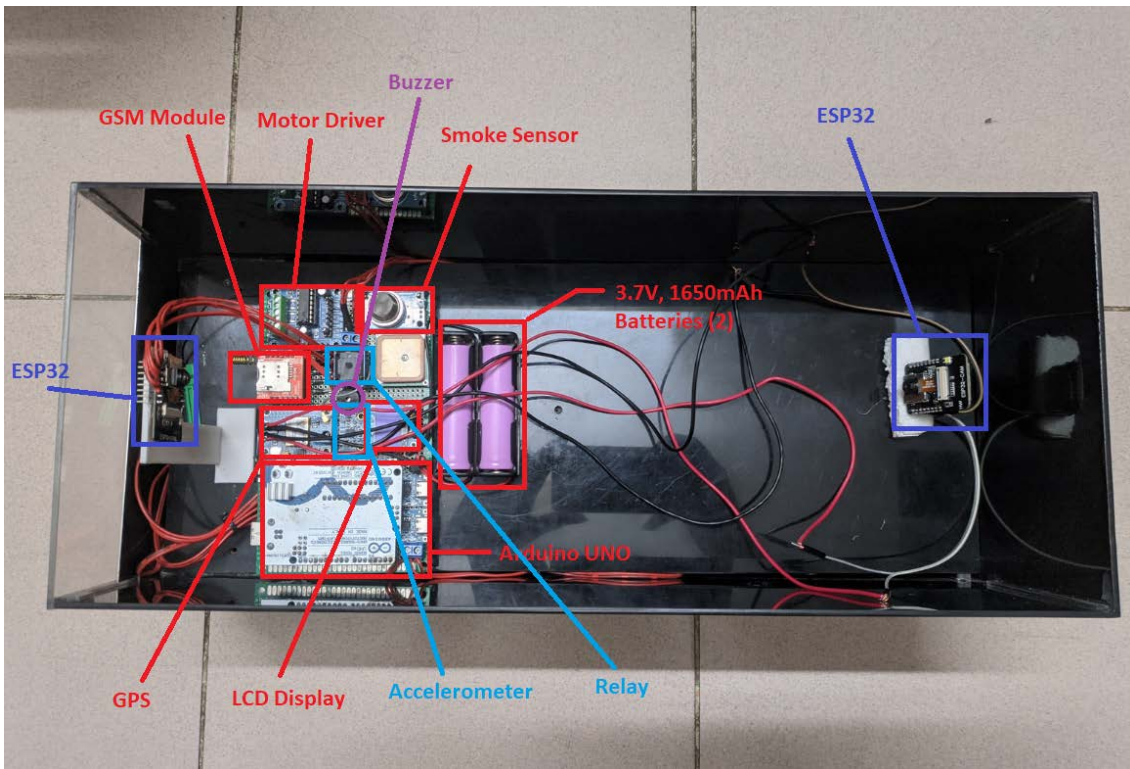

Figure-5.3- Name of the hardware components that are used to design the system.

The bus has four ultrasonic sensors. There are four sensors on the bus: two on the left and right sides, one at the front, and one on the back side of the bus. Here, one camera is used as a surveillance camera. Another one is used for image processing.

5.3 Evaluate the solution to meet desired need

5.3.1 Verification of the prototype:

i) Object detection through ultrasonic sensors:

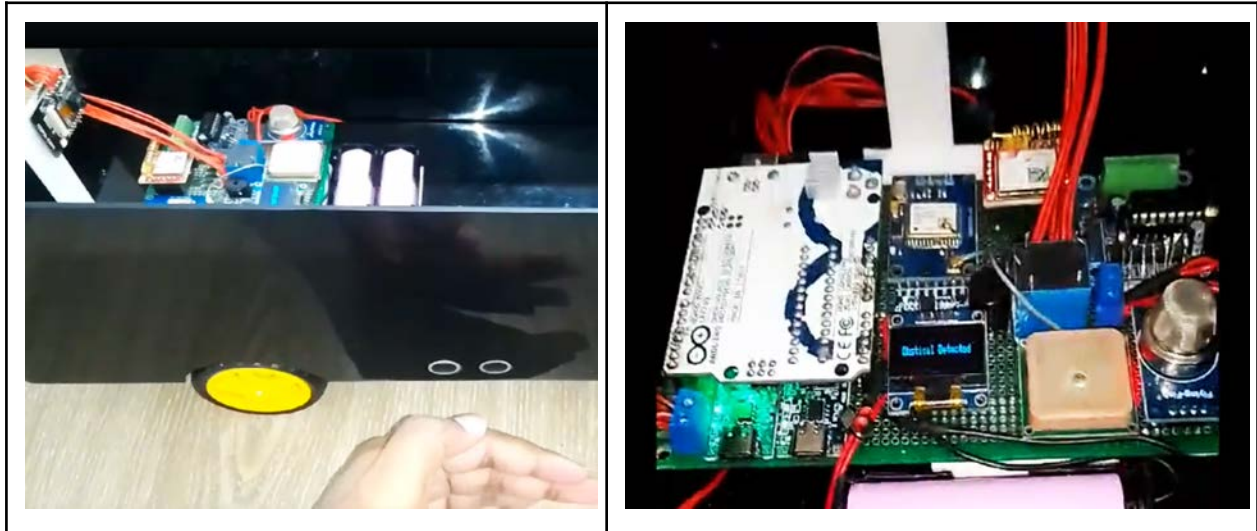

Figure-5.4-Object Detection

Here, an object is being detected by ultrasonic sensors. The object will be identified and 'Obstacle Detected' will appear on the LCD display if it is within a 15 cm range.

ii) Smoke detection through MQ-3 sensor:

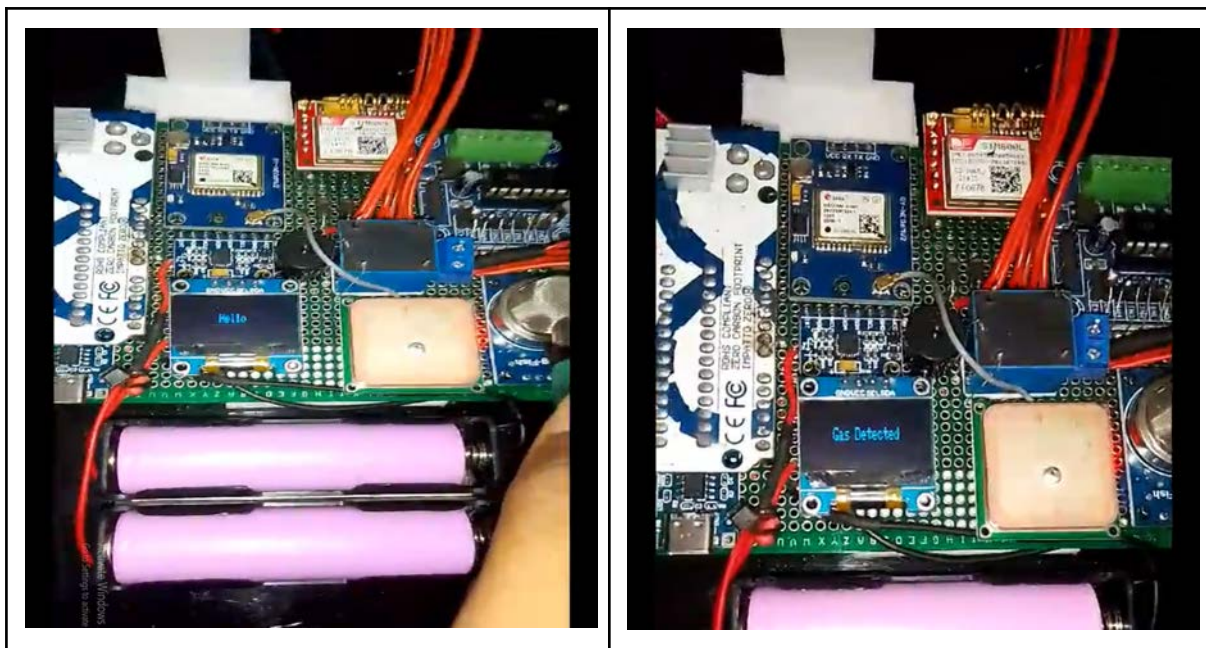

Figure-5.5-Smoke Detection

The MQ-3 smoke sensor is designed to identify carbon monoxide gas, which may be released within the bus in the event of a fire. Here, we are using a lighter to create smoke. 'Gas detected' will appear on the LCD; 'Gas not detected' will appear instead.

iii) Accident detection through an accelerometer:

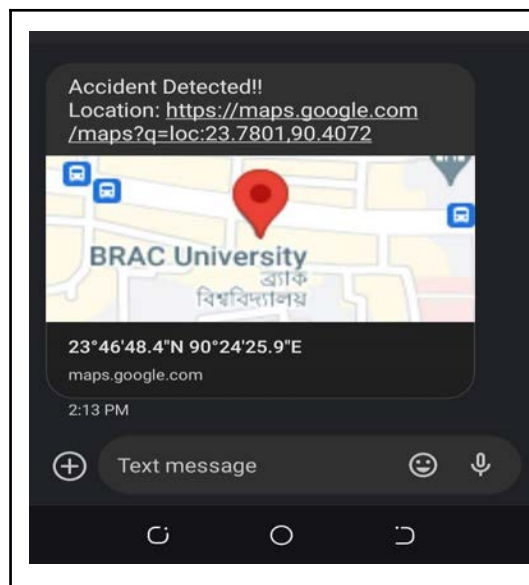
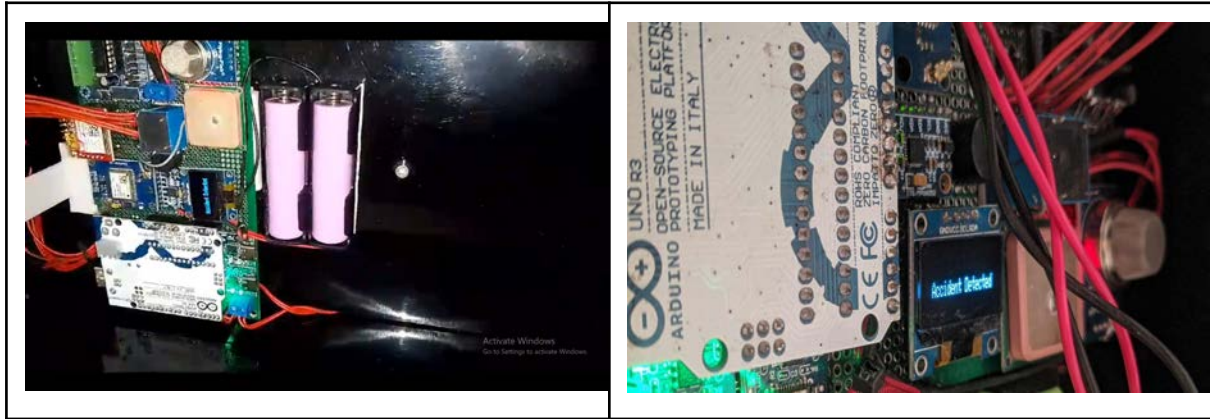

Figure-5.6-Accident Detection and message sending with location to the administration

iv) Real-time location tracking:

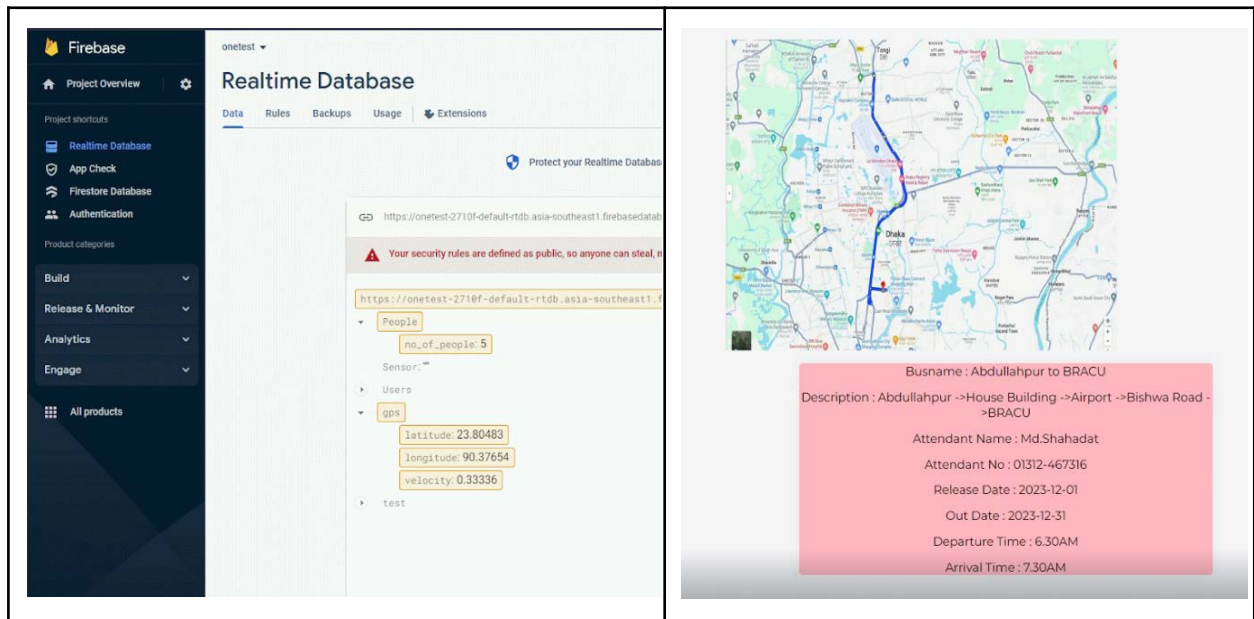

Figure-5.7- Location tracking through GPS module and sending the information to the website

v) Ticketing system:

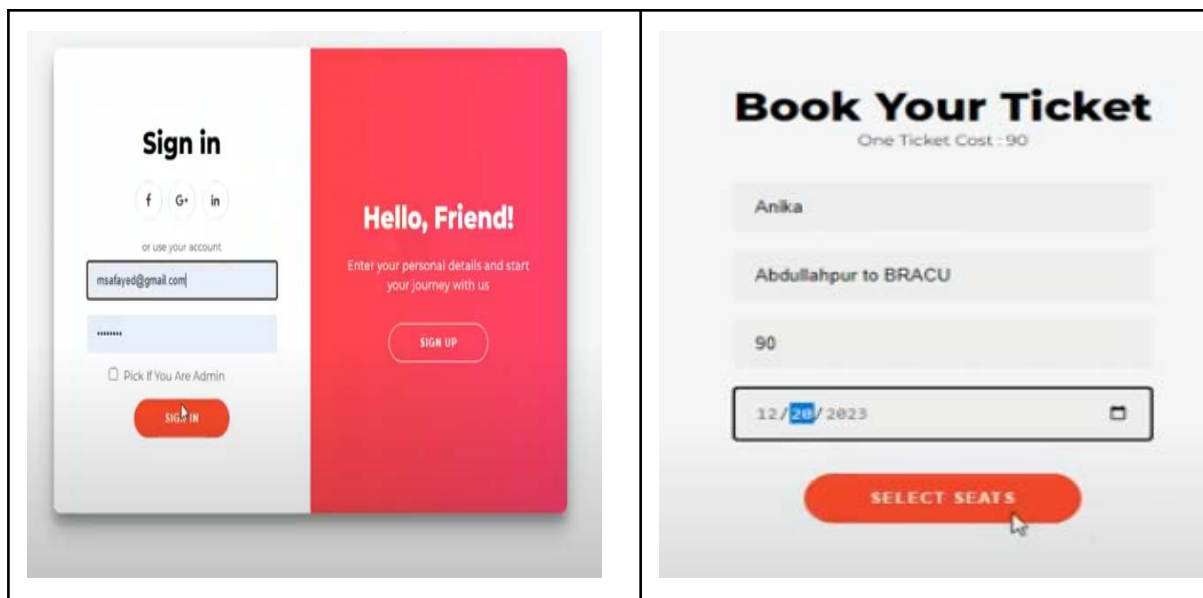



Figure-5.8- Online ticketing webpage

Tickets can be purchased remotely in this case. This ticketing website may be used to find out the status of the seats. Additionally, anyone can book seats as they see appropriate.

vi) People counting via image processing:

i) With real data-sets:



Figure-5.9- Model trained by real data-sets

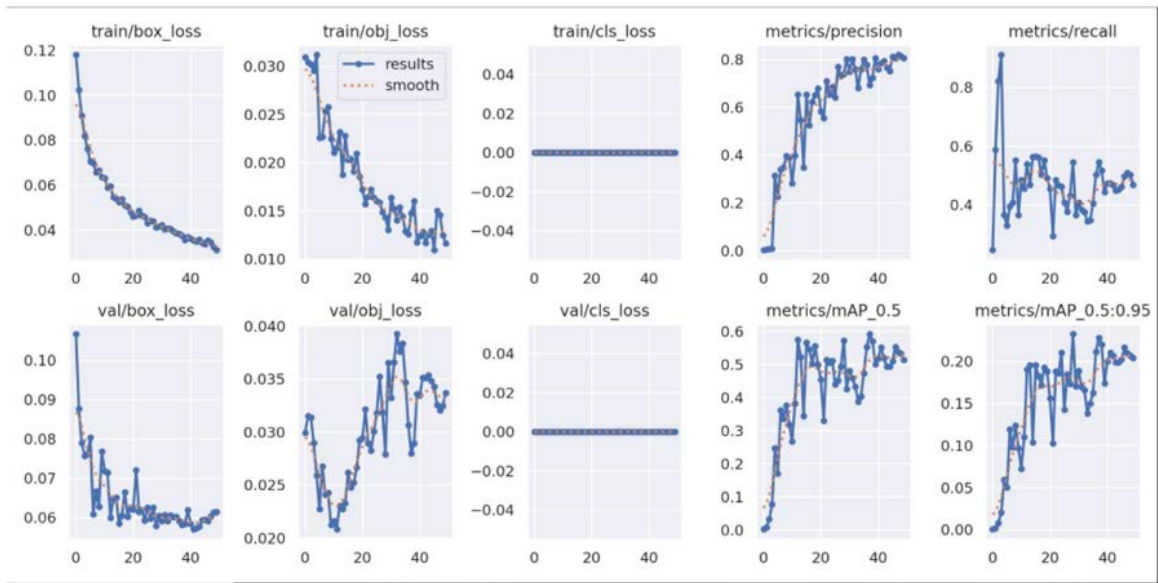

Figure-5.10- Graph of accuracy rate from real data-sets

This approach counts the number of persons by using machine learning (image processing). We used 300 real data sets that we had collected to train the model in order to determine the accuracy rate. The graph's matrices/mAP_0.5' indicates that the accuracy rate in this instance is 57%. However, the accuracy rate will increase if we train the model on additional datasets.

ii) With an open CV in Firebase:

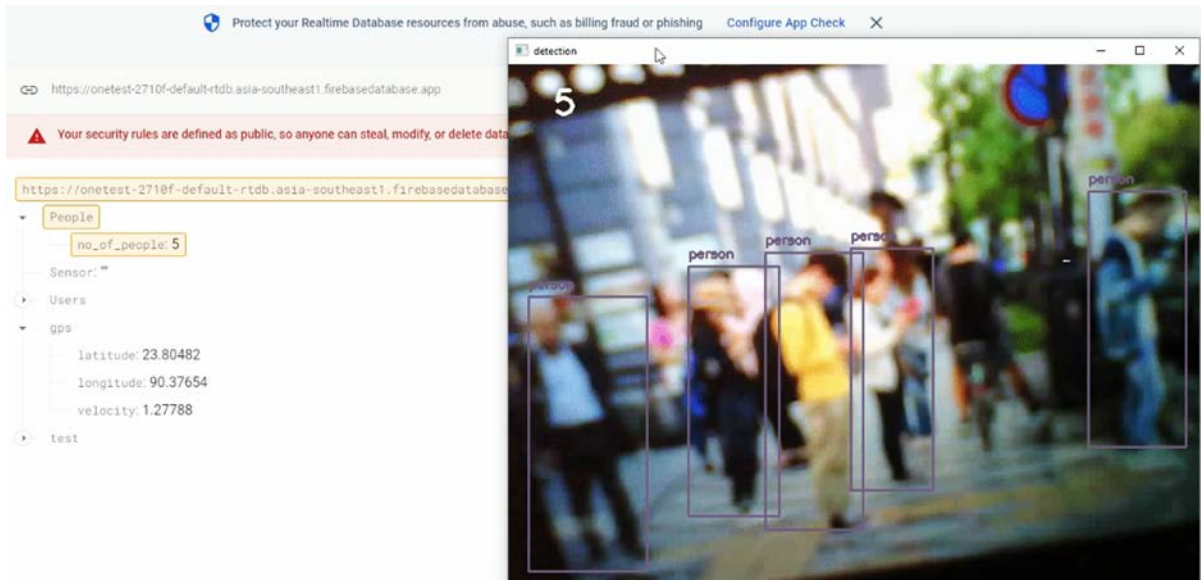

Figure-5.11- People counting through image processing with open cv

In this instance, the number of persons is likewise counted by image processing—actual data sets are not used. It's complete with the open CV. This shot identifies five people, and the firebase shows the total number of people present.

Project managers may make sure that the goals of the project are achieved and that the project design for a smart bus monitoring project is effectively verified by assessing these characteristics.[9]

5.4 Conclusion

To sum up, people counting can be done very effectively and efficiently using smart bus monitoring that combines machine learning and image processing. It provides real-time, accurate data. It also provides real-time bus location updates on the webpage, with data updated every 5 milliseconds. Additionally, this concept has more time-efficient online ticketing through a website. Through the website, users may remotely reserve their tickets and find out the status of their seats. Because there is no need for paper tickets in this system, it is ecologically friendly. In order to accomplish effective outcomes that satisfy project objectives, the project team must implement the final design and then go through the verification and assessment process.

Chapter 6: Impact Analysis and Project Sustainability. [CO3, CO4]

6.1 Introduction

As smart monitoring systems have developed, they have become increasingly vital in a variety of fields by providing improved control, analysis, and optimisation of different kinds of systems. Our project is focused on creating and deploying a cutting-edge smart monitoring system. This system intends to revolutionize monitoring capabilities across a variety of applications. It was constructed with an emphasis on cost-efficiency without sacrificing performance.

In today's technological scene, the importance of a low-cost yet highly efficient monitoring system cannot be stressed. Our system aims to optimize performance and minimize expenses by utilizing cutting-edge technologies and creative design ideas, guaranteeing broad accessibility and practicality. In addition to improving system performance, the smooth integration of intelligent monitoring capabilities has the potential to reduce entry barriers for a variety of applications and sectors.

By providing a cost-effective approach that enables enterprises and sectors to effectively optimize their operations, this research programme has the potential to rewrite the standards for monitoring systems. With the launch of this state-of-the-art monitoring system, we hope to further technological progress and efficiency optimisation across a range of industries, paving the way for a future characterized by more intelligent and affordable monitoring solutions

6.2 Assess the impact of solution

Our project's main goal is to completely transform public transit by creating an innovative bus monitoring system. Numerous advantages in the social, economic, and environmental domains are anticipated from this cutting-edge system. Our effort is to promote sustainable and accessible urban mobility by optimizing energy usage, boosting operational efficiency, and improving passenger experiences.

Legal:

This project will integrate a range of sensors, such as IR sensors, smoke sensors, accelerometer and other types of sensors, apart from this motor driver , relay switch, microcontroller . Every one of these sensors and components possesses a maximum temperature at which it can function. The production of these sensors is constrained by regulations set by higher authorities, who have also imposed a patent that mandates compliance with these restrictions. Our utmost priority in developing this project will be to adhere to all safety protocols mandated by authorities. By implementing these procedures, we may ensure the preservation of a safe and healthy environment. Additionally, adhering to these regulations will mitigate the risk of legal consequences associated with non-compliance.

Social and Cultural context

The addition of smart monitoring systems has a substantial social and cultural influence, promoting a fundamental change in the understanding of resources and societal actions. These systems provide immediate information on how resources are being used, allowing people and communities to adopt responsible behaviors. This helps create a culture of conservation and involvement with technology. This technology promotes education and collaboration, while also stimulating discussions on ethics, privacy, and sustainable values. It aims to cultivate a more aware and interconnected society that embraces innovation for sustainable living.

Safety and Security

In order to protect passengers from potential dangers, cameras with human detection capabilities continuously scan the area for unauthorized people or strange activity and also can give an idea about the seat availability . As a result, authorities to be notified immediately. By identifying suspicious things or possible threats on board, the system's object detection capacity helps to ensure a safe and secure environment for passengers. Furthermore, real-time location tracking helps with emergency response by giving authorities exact bus locations, facilitating prompt action during unanticipated crises, and guaranteeing passenger safety.[11]

Improved Operational Efficiency

By enabling online ticket purchases, cutting down on-boarding point wait times, and generally enhancing the traveler experience, the provision of an online ticketing system offers travelers convenience. These surveillance systems provide travelers with a sense of security and comfort while they are traveling, which promotes a happy travel experience.

Cost Saving and Efficiency

Implementing location tracking to optimize routes greatly saves travel time, hence minimizing fuel usage and operational expenses for transportation services. The ability to monitor in real-time enables the discovery of optimal routes, thereby avoiding traffic jams and optimizing travel pathways. Concurrently, the implementation of online ticketing systems simplifies the ticketing process, resulting in increased operational efficiency by decreasing the need for human labor and resource allocation. This leads to cost savings and improved financial performance.

Environmental Impact

Optimizing route planning is a direct and effective way to conserve fuel, resulting in a considerable decrease in carbon emissions and making a meaningful contribution to environmental sustainability. The technology helps reduce fuel consumption and optimize travel routes, thereby lowering the environmental impact of transportation activities. This promotes cleaner air and long-term ecological benefits.

Technological Advancements

The implementation of modern technology in transportation promotes innovation and stimulates ongoing technical progress. This encompasses advanced surveillance systems, based on artificial intelligence decision-making algorithms, and incorporation into smart city projects. The persistent pursuit of technology advancement is transforming transport infrastructure, resulting in improved efficiency, safety, and overall system performance. This drive is also moving the sector towards additional innovation and progress.

6.3 Evaluate the sustainability

The SWOT analysis matrix will be utilized to evaluate sustainability by providing a comprehensive understanding of how to assess its components. The acronym SWOT stands for Strengths, Weaknesses, Opportunities, and Threats. Now, let's get into the variables of the SWOT analysis. In the SWOT analysis, we found out the following:

SWOT Analysis Table:

Strengths	Weaknesses
<ul style="list-style-type: none">● Accurate passenger counting● Improved Safety● Environmentally Friendly● Versatility or adaptability● Real-time tracking● Increased efficiency	<ul style="list-style-type: none">● Requires installation● Requires maintenance● Limited Functionality
Opportunities	Threats
<ul style="list-style-type: none">● Increased demand for efficient and reliable public transportation● Integration with other transportation systems● Partnership with transportation companies	<ul style="list-style-type: none">● Limited market● Cybersecurity threats● Resistance to change

Table 6.1: This table shows the SWOT analysis of developed solution

Strengths:

- Accurate passenger counting: The device is capable of counting the exact number of passengers inside a bus, ensuring precise data.
- Real-time tracking: The device gives the exact location of the bus in real-time, making it easier to track the bus.
- Increased efficiency: With accurate passenger counting and location tracking, the

device can help bus companies increase their operational efficiency.

- **Versatility:** The device can be used for various types of public transportation, including buses, trains, and trams.
- **Environmentally friendly:** With accurate passenger counting and tracking, the device can help reduce emissions by optimizing transportation routes.
- **Improved safety:** The device can help bus companies ensure passenger safety by preventing overcrowding.

Weaknesses:

- **Requires installation:** The device requires installation, which can be a cumbersome process and may require additional resources.
- **Requires maintenance:** The device will require regular maintenance to ensure accurate readings and optimal performance.
- **Limited functionality:** The device only serves one function and does not offer additional features that may be available in more advanced transportation solutions.

Opportunities:

- **Increased demand:** With increasing demand for efficient and reliable public transportation, there may be a significant opportunity for the device to gain wider adoption.
- **Integration with other transportation systems:** The device can potentially be integrated with other transportation systems to provide a more comprehensive solution.
- **Partnership with transportation companies:** The device can be marketed to transportation companies as a cost-effective and reliable solution to monitor passenger Traffic.

Threats:

- **Limited market:** The market for the device may be limited, depending on the size and scope of public transportation systems in specific regions.
- **Cybersecurity threats:** The device's data collection capabilities may make it vulnerable to cyber-attacks, compromising passenger data.
- **Resistance to change:** Resistance from transportation companies or passengers to adopting new technology may limit the device's adoption and usage.

29/4

6.4 Conclusion

Eventually, impact analysis and sustainability evaluations are crucial in every project to assess its effects on the environment, society, and economy, and to guarantee that the project is executed and implemented in a secure and accountable manner. This leads to stakeholders being able to take moves more cautiously and also helps in devising solutions for more robust tactics to minimize them.

Chapter 7: Engineering Project Management. [CO11, CO14]

7.1 Introduction

Project Management is a very important part of reaching the ultimate goal of a project. Without proper management it becomes very difficult to fulfill the expected outcomes of the project. From our side, we have organized our project in such a way that we can reach our goal in due time. We have completed our Final Year Design Project in three steps which are P(proposal writing), D(design report), C(completion) under the guidance of our respected ATC panel. In every step we put in tremendous effort as a team to ensure our project completion. As a team we have maintained effective communication within ourselves and with our respected advisors. For proper planning, we prepared a Gantt chart for every step and also maintained a logbook from which we could review our activities to help us solve our errors.

7.2 Define, plan and manage engineering project

Project Plan for FYDP (P)

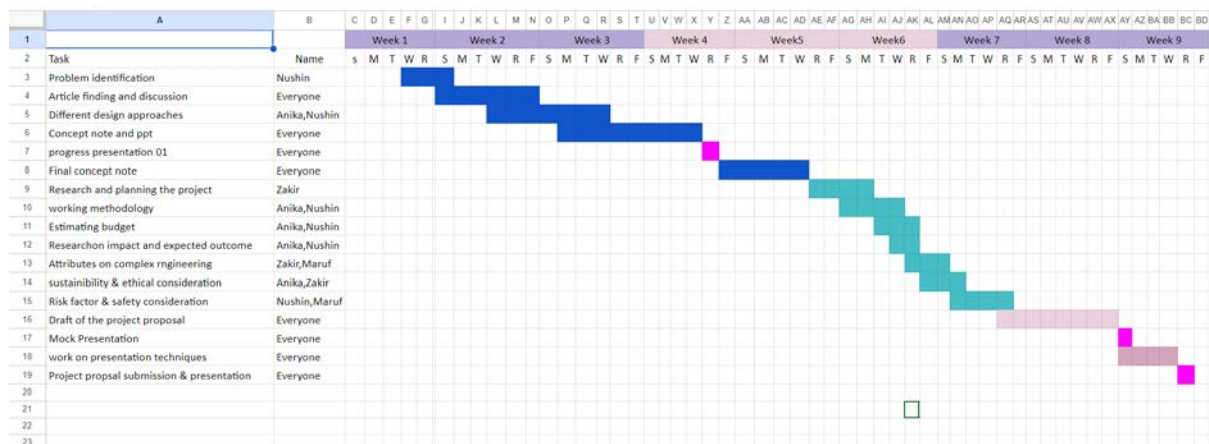

Figure-7.1- FYDP(P) Project Plan

Task	Start Date	End Date	Duration
Problem Identification	05.02.2023	23.02.2023	21
Article finding and discussion	18.02.2023	08.03.2023	20
Different design approaches	10.03.2023	28.03.2023	18
Concept note & ppt	16.03.2023	30.03.2023	14
Progress presentation	31.03.2023	01.04.2023	2
Final Concept Note	02.04.2023	12.04.2023	10
Research and planning the project	13.04.2023	23.04.2023	10
Working methodology	15.04.2023	29.04.2023	14
Estimating budget	23.04.2023	23.04.2023	1
Research on Impact and expected outcome	15.04.2023	21.04.2023	7
Attributes on complex engineering	23.04.2023	23.04.2023	1
Sustainability and ethical consideration	20.04.2023	22.04.2023	2
Risk factor and safety consideration	16.04.2023	19.04.2023	3
Draft of the project proposal	20.04.2023	20.04.2023	1
Mock Presentation	22.04.2023	22.04.2023	1
Work on presentation techniques	21.04.2023	21.04.2023	1
Project proposal submission and presentation	23.04.2023	26.04.2023	4

Table 7.1: Project Plan of FYDP(P)

Project Plan FYDP(D)

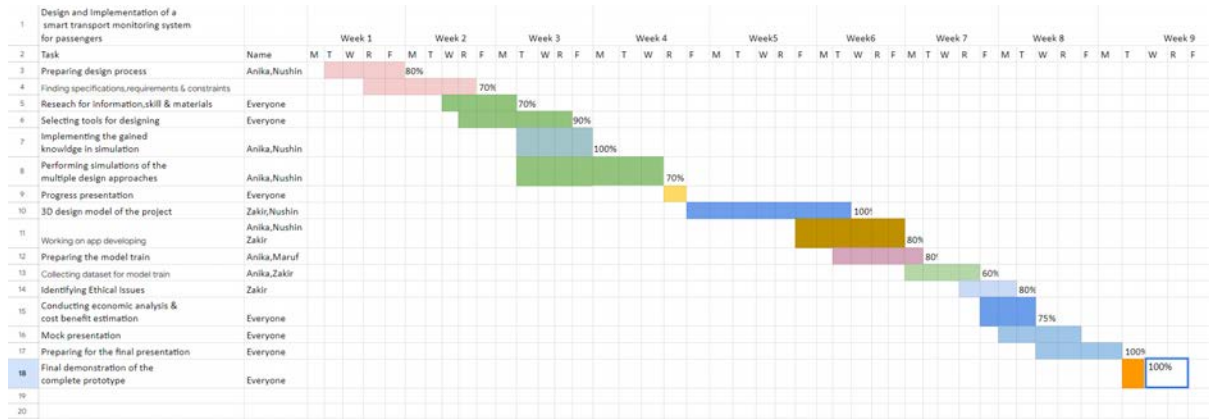

Figure-7.2- FYDP(D) Project Plan

Task	Start Date	End Date	Duration
Preparing design process	20.05.2023	12.06.2023	22
Finding specification ,requirements and constraints	20.05.2023	30.05.2023	10
Research for information, skill and materials	25.05.2023	15.06.2023	20
selecting tools for designing	01.06.2023	07.06.2023	6
Implementing the gained knowledge in simulation	05.06.2023	15.06.2023	10
Performing simulation of the multiple design approaches	10.06.2023	25.06.2023	15
Progress presentation	01.07.2023	02.07.2023	2
3D design model of the project	20.06.2023	15.07.2023	25
Working on developing app	10.07.2023	05.08.2023	25
Preparing the model train	15.07.2023	15.08.2023	30
Collecting dataset for	20.07.2023	30.07.2023	10

model train			
Identifying Ethical Issues	16.08.2023	16.08.2023	1
Conducting economic analysis	17.08.2023	18.08.2023	2
Mock presentation	19.08.2023	19.08.2023	1
Preparing for final presentation	20.08.2023	23.08.2023	4
Final demonstration of the complete prototype	24.08.2023	24.08.2023	1

Table 7.2: Project Plan of FYDP(D)

Project Plan for FYDP (C)

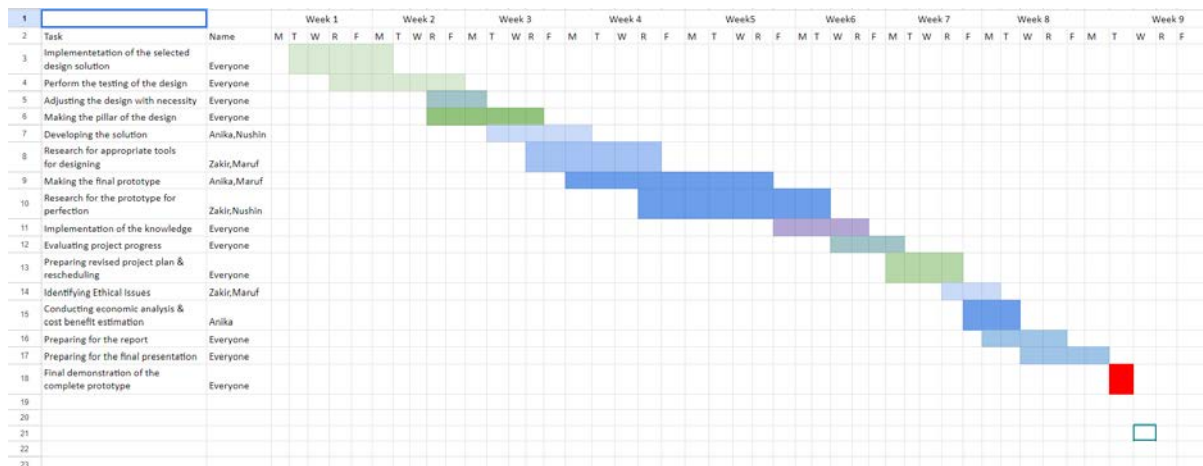

Figure-7.3- FYDP (C) Project Plan

Task	Start Date	End Date	Duration
Implementation of the selected design solution	20.09.2023	15.10.2023	25
Perform the testing of the design	05.10.2023	30.10.2023	25
Adjusting the design with necessity	15.10.2023	05.11.2023	20
Making the pillar of the design	01.11.2023	10.11.2023	10
Developing the solution	05.11.2023	10.12.2023	35

Research for the prototype for perfection	01.11.2023	20.11.2023	20
Implementation of the knowledge	10.11.2023	01.12.2023	21
Evaluating project progress	15.11.2023	20.11.2023	5
Preparing revised project plan and rescheduling	01.12.2023	10.12.2023	10
Identifying Ethical issues	05.12.2023	05.12.2023	1
Conducting Economic Analysis	01.12.2023	10.12.2023	10
Preparing for the final presentation	05.12.2023	13.12.2023	9
Final demonstration of the complete prototype	14.12.2023	14.12.2023	1
Completing report writing	15.12.2023	31.12.2023	16

Table 7.3: Project Plan of FYDP(C)

7.3 Evaluate project progress

On 17 January of spring 2023 semester we started working on our project according to our respected ATC panel members. At First, we struggled to find a topic which fills all the criteria of final year design project requirements. By the guidance of respected ATC members we chose the topic ‘Design and Implementation of a Smart Transport monitoring system for passengers’ and started working on this. In order to obtain accurate information and gain a sense of the process, we began reading various papers, articles, and journals linked to our subject.

We have prepared a work schedule for every semester. We divided up the work among the team members equally and made sure the logbook was maintained up to date. Following the project plan, we set to work on our project. In addition to other assignments, we had to finish our homework online and at the university. We kept up our weekly online meetings. Making the project plans was our task for the FYDP's first semester. We therefore discussed the project's design, procedures, requirements, and financial plan. We also emphasized the risks, legality, and sustainability factors. The following semester (400D) is when we started working on the simulation component of our project. Here, we also give a quick overview of

the various potential answers to the issues facing our project, simulate each one, and discuss the rationale behind our decision. Most component costs are rising quickly due to the high rate of inflation, therefore we also need to make budget adjustments. As a result, we provided evidence supporting the importance of our idea and how it would be advantageous for the environment, people, and the economy. Ultimately, during the last semester of our research, we successfully finished our monitoring by using the device prototype. We started working on the hardware and software components before the semester started. The hardware setup was then finished in the first two weeks of the semester by putting several parts, such as sensors and microcontrollers, together. Then, by evaluating a number of factors, we started to collect data. Real datasets were gathered in order to improve efficiency and count people in image processing.

7.4 Conclusion

In the real world of work, engineers will encounter challenges including tight budgets, scarce supplies, and uneven workloads. To get beyond these challenges and accomplish their objectives, engineers will need to demonstrate their situational management abilities. Our Final Year Design Project (FYDP) presented us with a number of difficulties. Nevertheless, with the help of the ATC panel members and a team meeting, we were able to resolve them.

Chapter 8: Economical Analysis. [CO12]

8.1 Introduction

Examining and contrasting different investment options and making judgments about investments based on the projects' financial returns are the aims of economic analysis. Investments may help both the local or regional economies and the national economy overall through better resource allocation. Economic analysis helps determine if a project is beneficial by calculating the financial ratio of all project expenses to all benefits. It can also make it possible to compare treatments that differ greatly from one another in terms of their scope, cost, and period of application. But it requires a lot of large financial assumptions on all the advantages. In the pursuit of modernizing and optimizing public transportation systems, the integration of advanced technologies plays a pivotal role in enhancing operational efficiency, passenger satisfaction, and overall safety. This analysis aims to provide a meticulous breakdown of capital and operational expenditures, explore potential revenue streams, and evaluate the project's financial viability through key performance indicators.

8.2 Economic analysis

This is the budget of our prototype:

Component	Quantity	Price(BDT)	Description
Jumper wire	120-150	Tk500	For connection (3.3V-5V)
ESP32 camera	1	Tk900	Monitoring and image processing
Arduino Uno	1	Tk1100	Used for control system
Vibration sensor	1	Tk 85	able to detect accidents
Ultrasonic sensor	4	Tk360	Able to detect object near 2cm
Gas sensor	1	Tk 175	able to detect gas leakage
GPS module	1	Tk 1000	able to track location and time
GSM Module	1	Tk450	Able to send SMS, MMS, GPRS and audio
LCD Display	1	Tk200	16 by 2 display with reduced overall wiring
Power Supply	1	Tk 1500	For sufficient power supply

Buzzer & PCB	2	Tk 170	To create sound
Body structure	1	Tk 6000	
Total		Tk 12440	

Table 8.1: Budget of our prototype

This is the budget of our project in real life:

Component	Quantity	Price(BDT)
Dual Lens Camera	2	Tk 9,000
People counting camera	2	Tk 20,598
Arduino Uno	1	Tk 1,110
Vibration sensor	1	Tk 380
Ultrasonic sensor	4	Tk 360
Gas sensor	1	Tk 175
GPS module	1	Tk 10,000
GSM module	1	Tk 450
LCD screen	1	Tk 13000
Power supply	1	Tk 11,000
Buzzer	1	Tk 849
Wires	--	Tk 5,000
Miscellaneous	--	Tk 1000000
Total		1054000

Table 8.2: Budget of our real life project

8.3 Cost benefit analysis

Benefits

i) Increased Efficiency:

Real-time tracking enhances route optimization and scheduling, leading to operational efficiency.

ii) Enhanced Passenger Convenience:

Online ticketing systems provide convenience for passengers, potentially increasing ridership.

iii) Safety Improvements:

Integration of ultrasonic and gas sensors enhances passenger safety and accident detection.

iv) Website:

Allows it to run advertisements to generate more revenue.

Costs:

i) Initial Investment:

Significant upfront costs for hardware, software development, and system integration.

ii) Maintenance Costs:

Ongoing expenses for maintenance, updates, and hardware replacements.

iii) Connectivity Costs:

Monthly expenses for internet connectivity will contribute to operational costs.

8.4 Evaluate economic and financial aspects

In here, we can see that our cost analysis

Initial Investment + Maintenance + Connectivity = Tk. 1054000

Benefit Analysis

Daily Ticket Sales = 160 tickets if we assume a bus goes to a destination and comes back four times. So, $4 \times 40 = 160$.

Yearly Ticket Sales = $160 \times 365 = 58400$

The Ticket Price = Tk. 90 and if we make 5% of each ticket, we get Tk. 4.5

Yearly ticket sales = $4.5 \times 58400 = 262800$

We can assume to advertise through our website and make = $\text{Tk. } 50/\text{day} \times 365 = 18250$

Total Revenue = 281050

Time Period to Make the Project = 1 year

The lifespan of the Project = 10 years

Internal Rate of Return = 14%

Payback Period = $3 - (-210850/281050) = 3.75$ years

8.5 Conclusion

The economic analysis shows a balance between the initial capital investment and the prospective long-term rewards. Advanced technology integration strives to improve operating efficiency, passenger satisfaction, and overall safety. With a respectable IRR of 14% and a relatively quick payback period of 3.75 years, the project has a promising financial future. The benefits, which include higher efficiency, improved passenger convenience, and safety enhancements, all add to the bus tracking system's overall economic viability. Furthermore, the potential money from daily ticket sales and internet adverts contributes to the project's financial viability over its 10-year lifespan.

Chapter 9: Ethics and Professional Responsibilities [CO13, CO2]

9.1 Introduction

The importance of ethics and professional obligations is highlighted in order to ensure the moral, legal, and responsible administration of a project. Important factors to take into account are following moral guidelines, following laws, and carefully assessing the possible effects on each and every project stakeholder.

9.2 Identify ethical issues and professional responsibility

It is undeniable that people abstain from acts that are detrimental to society because of moral concerns. Furthermore, ethical considerations can reduce risks, encourage positive outcomes, boost confidence, and support a successful project's reputation. When it comes to producing our test setup commercially, there are a few things to consider.

It's imperative that we obtain consent and formally commit to our efforts by signing a legal agreement at each chosen area before we begin implementing our best method. Simultaneously, great care will be taken to replace any potentially hazardous parts of the apparatus during test setup. Furthermore, it's critical to appropriately cite and attribute any outside sources of material that we use in our project. In addition, it is crucial to strictly follow official regulations in order to avoid using anything that the authorities have declared to be illegal. Finally, we are bound by a specific commitment to safeguard confidentiality, which means that the results of our work are not shared with outside parties. This all-encompassing strategy highlights our commitment to moral, responsible, and lawful behavior for the duration of our endeavor.[12]

9.3 Apply ethical issues and professional responsibility

- **Data Privacy:** One of the main ethical concerns when developing any system is data privacy. This system will be collecting and processing sensitive information about passengers, such as their location and travel patterns. It is important to ensure that this information is kept secure and is not used for any unauthorized purposes.

- **Informed Consent:** Passengers should be informed about the collection and use of their data and should have the option to opt out if they do not wish to participate in the system. The system should also provide clear and easy-to-understand explanations of how the data will be used.

- **Transparency:** The system should be transparent about how it collects and uses data, including what data is collected and how it is processed. This will help build trust with passengers and ensure that the system is being used ethically.

- **Non-Discrimination:** The system should not discriminate against any passengers based on their race, gender, age, or any other factors. The data collected should be used solely for the purpose of improving the service and should not be used to discriminate against any passengers.

For developing our project where we had to capture images of passengers in different local buses for the purpose of the model training, we had given importance about the consent of the passengers. For this reason, we asked for their consent before capturing their images. We explained to them that these images will only be used for the beneficiary of our project and we did make sure that the images won't be used for any harmful reason. In this process, we took sign from the people as a proof of their consent before capturing their images.

Risk Management and Contingency Plan

Identification of risks:

- **Electric shock:** Workers who install or maintain the system may come into contact

with live electrical components and experience electric shocks, which can result in severe damage.

- **Cybersecurity risks:** The system may be vulnerable to cyber attacks or data breaches, leading to the theft of sensitive passenger data or system malfunction, which can pose a risk to passenger safety and privacy.

Risk Level:

Risk	Risk Level
Electric shock during installation or maintenance	High
Physical injury during installation or maintenance	High
Cyber-attacks on the system	High
Worker fatigue leads to accidents or errors	Moderate
Lack of user acceptance	Moderate
Communication breakdown between personnel	Moderate
Adverse weather conditions during installation or maintenance	Moderate
Inadequate maintenance	Low
Traffic accidents during installation or maintenance	Low
Environmental hazards during installation or maintenance	Low

Table 9.1: Table of the risk level of our project

Risk Contingency Plan:

Risk events	Response	Contingency	Trigger	Responsibility
--------------------	-----------------	--------------------	----------------	-----------------------

Electric Shock	<ul style="list-style-type: none"> • Adding heavy insulation will reduce the current flow. • Making sure no components come in contact with water • Proper Grounding 	The main switch is a relay.	<ul style="list-style-type: none"> • Faulty Ground • Water coming into contact 	Safayed
Power System Failure	<ul style="list-style-type: none"> • Backup power will be turned on. 	Proper maintenance of the device	Drops in voltage or an abrupt system shutdown	Nushin
Software Crash	<ul style="list-style-type: none"> • Rebooting the system • Updated softwares 	Scheduled software updates	<ul style="list-style-type: none"> • Data collection becomes unresponsive • System comes to a halt. 	Zakir
Cyber Attack	<ul style="list-style-type: none"> • Shutdown the system immediately. 	<ul style="list-style-type: none"> • Firewall Access Management • Data Backup 	security breach of the system	Anika

Table 9.2: Table of the risk contingency plan of our project

Safety Consideration

A few things should be kept in consideration while building the system.

User Safety

- Ensure all the data exchanged between the system and the server is fully encrypted to prevent unauthorized access.
- The software should have an SOS button in case of an emergency to inform nearby officials or close friends immediately.

Device Safety

- Ensure that the data collected by the system is backed up regularly to prevent data loss in the event of a system failure.
- The system should have backup power in case there is a power outage.
- Ensure that the device is placed in an appropriate location for monitoring the passengers and on a stable enough platform to avoid becoming a hazard.

Personnel Safety

- Proper labeling to indicate any potential hazards.
- Constructed using non-toxic materials to minimize health risks.

9.4 Conclusion

In summary, these factors are critical to a project development lifecycle since they guarantee that the project is executed in an ethical and responsible manner.

To sum up, professional and ethical obligations are essential to any project since they guarantee that it will be carried out in an ethical and responsible manner. Project managers can guarantee the project's success and sustainability while also promoting community well-being by taking into account the possible effects of the project on stakeholders and abiding by legal and ethical requirements.

Chapter 10: Conclusion and Future Work.

10.1 Project summary/Conclusion

The objective of the project is to create and execute a smart transportation surveillance system for commuters in Bangladesh. The country faces a significant problem of traffic congestion, especially in urban areas, as a result of the high population density. Buses continue to be the favored means of transit for numerous individuals; yet, the frequent occurrence of waiting for buses with unpredictable arrival times is a prevalent time-consuming inconvenience, particularly for working professionals and students who rely on punctual transportation. Standing on the road for transport vehicles can lead to traffic congestion and obstruct roads, particularly during rush hours. The project aims to deploy a monitoring system on buses in Bangladesh to tackle the aforementioned challenges and enhance the overall efficiency, safety, and security of public transportation. The primary goals of the project encompass the creation and execution of a surveillance system for Intelligent Public Transportation. This system will furnish instantaneous data regarding the whereabouts of buses, their timetables, and routes to transportation authorities, bus companies, and commuters. Additionally, it aims to curtail operational expenses for bus companies by optimizing routes and schedules. The project encompasses both operational and non-operational prerequisites. The capacity management system should be interoperable with various bus types and communication systems, and it should be easily maintainable and updatable. In conclusion, the design and implementation of a smart transport monitoring system for passengers hold significant potential to revolutionize the way we perceive and engage with public transportation. Moreover, the efficiency enhancement aspect of this project brings about a transformative shift in the way transportation systems are managed. Safety enhancement stands as a paramount outcome of this endeavor. As we look toward the future, this smart transport monitoring system serves as a testament to the positive impact that innovation can have on the quality of our daily lives, fostering a more connected, efficient, and secure transportation ecosystem for passengers and communities alike.

10.2 Future work

In Bangladesh, the future development of a bus tracking system for smart public transportation involves technological advancements, regulatory collaboration, and community engagement to create an inclusive, efficient, and sustainable transport solution.

1. **Infrastructure Integration:** Integrate GPS technology and improve connectivity along routes to ensure compatibility with widespread smartphone usage.
2. **Accessibility Enhancement:** Develop user-friendly interfaces in local languages and implement SMS-based services for broader accessibility.
3. **Regulatory Collaboration:** Collaborate with transportation authorities to establish standardized regulations for efficient system implementation across agencies.
4. **Data Security Focus:** Prioritize robust data security measures to protect commuters' information and ensure compliance with local privacy laws.

5. **Payment System Integration:** Link the tracking system with digital payment by building an app for cashless transactions.
6. **Community Engagement:** Conduct awareness programs to educate the public on the system's benefits and involve communities in its development.
7. **Sustainability Initiatives:** Explore eco-friendly transportation modes and optimize routes for reduced fuel consumption and environmental impact.
8. **Continuous Improvement:** Implement feedback mechanisms for ongoing enhancements, ensuring the system's relevance and effectiveness.

Chapter 11: Identification of Complex Engineering Problems and Activities.

11.1: Identify the attribute of complex engineering problem (EP)

A few structures exist for challenging building problems. Below, we're attempting to clarify them.

- **Depth of knowledge required:** To design a functional building addition, we must have precise understanding of the relevant sector. We are unable to give a project our full attention without trustworthy information. Thus, to a certain degree, it is necessary to possess precise knowledge regarding almost all issues.
- **Range of conflicting requirements:** This suggests that when we begin researching or developing anything, there could be some clashing concerns. Our goal should be to address those issues and offer a solution that is both safe and persuasive to the degree that it is needed. While working on projects that could touch on these contentious problems, our objective will be to comprehend them and provide a safe answer. These problems might be legal, technological, ecological, etc.
- **Depth of analysis required:** This is an additional crucial viewpoint on difficult technical problems. It takes a sufficient amount of in-depth examination to develop to a productive degree. Without it, a great deal of stuff that may be beyond our comprehension will occur in the future. Consequently, the initiative will serve no purpose.
- **Familiarity of issues:** This indicates that the general public won't be aware of an unused expansion when it is planned, proposed, or implemented. Additionally, we would need to update or modernize the earlier solutions because this problem may potentially be related to everyday concerns.
- **Extent of applicable codes:** When developing a complex engineering project, there may be a variety of issues with engineering procedures. In order to complete the project, we have to abide by international laws and guidelines. If not, the project will not succeed.
- **Extent of stakeholder involvement and needs:** The approximate degree of cooperation between partners and the necessity for conversations upon partner request. This means that we have to ensure that the endeavor structure helps the intended audience of our endeavor.
- **Interdependence:** This concept implies that problems are interrelated, meaning that solving the problem will lead to the best possible solution. We only fully utilize a small number of the aforementioned qualities.

Attributes of Complex Engineering Problems (EP)

	Attributes	Put tick (√) as appropriate
P1	Depth of knowledge required	√
P2	Range of conflicting requirements	x
P3	Depth of analysis required	√
P4	Familiarity of issues	√
P5	Extent of applicable codes	x
P6	Extent of stakeholder involvement and needs	√
P7	Interdependence	√

Table 11.1: Table of the attributes of Complex Engineering Problems (EP)

11.2: Provide reasoning how the project address selected attribute (EP)

Understanding sensor function, design, and networking requires specialized expertise. Several relevant research articles are being examined in order to do that. This satisfies the P1 criterion.

To create two different approaches for the project that meet the requirements, thorough research is necessary. The condition for P3 is satisfied by this.

Familiarity is seen in our country as well as in other developed countries, which fulfills criterion P4.

Stakeholders are involved with this project. A small number of stakeholders are involved in this initiative. The passengers who are directly involved in the initiative are the first and most crucial. We visited other bus stations and struck up conversations with the locals there, learning about their problems with transportation. Second, the businesses from whom we sourced every piece of equipment needed to construct the prototype. For instance, we bought certain equipment from RoboticsBD, a project stakeholder. We can also include certain outside companies that will use our technology to interact with people directly. To get the greatest outcomes, we may collaborate with these companies to enhance our bus monitoring system and continuously update it with fresh data. We have discussed this with Mr. Azmal Uddin Ahmed, the Chairman of Al-Arafat Paribahan and Bolaka, as well as the President and Treasurer of Dhaka Sarak Paribahan Malik Samity. For now, they are doing tasks manually.

The drivers provide them with updates on the bus's location. The conductor gives them the bus fare. They are therefore unable to establish the accuracy of these claims. Furthermore, they are unable to determine the bus's passenger count. Therefore, there's a good probability that unethical things will happen, such as drivers lying to the administration about where they are and asking for additional money for fuel. In addition, conductors could misrepresent the number of passengers and underpay the administration. But recently, an app named "Jatrik" was released to the bus companies, where conductors may enter passengers' information to issue tickets to customers. However, conductors can also perform unethical work. They may merely enter the details of a small number of passengers and collect cash from the remaining passengers for the bus price. Our technology can track the position of buses in real-time and count people using real-time image processing, so if we offer it to those bus operators, all of these issues will be solved. Furthermore, we provide online tickets. Additionally, our website provides the administration and passengers with access to all of this information. Additionally, our system offers safety elements that guarantee the protection of the people on the buses as well as the bus itself. Hence, it fulfills criterion P6.

When an accident is detected, our system notifies the administration and provides the bus location, which is reliant on the notification system. Not only that, but knowing the information about the real-time bus location as well as people counting through image processing and ticket purchasing relies heavily on the website. This fulfills the requirement for P7.

11.3 Identify the attribute of complex engineering activities (EA)

The following illustrates the characteristics of complicated building activities (EA):

- **Range of resources:** To develop the project, a wide range of resources, including cash, materials, equipment expertise, and human resource requirements, are required. After reading through several research articles, we gathered data on hardware, software, and necessary methodologies before finishing the designs.
- **Level of interaction:** This project's degree of interactive engagement is thought to be significant. A broad understanding of networking, design, and electronics is needed. Additionally, we had to gather information from the stakeholders by interviewing them.
- **Innovation:** Seeing a building project from the standpoint of development gives us the opportunity to make something valuable for others out of nothing. Because of this, the solution that is required to help the intended group must offer a sufficient level of productivity.
- **Consequences for society and the environment:** The concept intends to enhance both passenger security and the bus's environment. Additionally, we have made every effort to create an environment friendly project. It will also satisfy the stakeholders' demands.

Attributes of Complex Engineering Activities (EA)

	Attributes	Put tick (√) as appropriate
A1	Range of resource	√
A2	Level of interaction	√
A3	Innovation	x
A4	Consequences for society and the environment	√
A5	Familiarity	√

Table 11.2: Table of the attributes of Complex Engineering Activities (EA)

11.4 Provide reasoning how the project address selected attribute (EA)

In order to gather data, we first looked up details about electrical sensors and microcontrollers on a number of websites. Next, in order to improve the accuracy of image processing, we gather actual data sets. Once more, we get to observe how our sensors respond to various stimuli, enabling us to fine-tune our parameter modifications and meet the A1 requirements.

A project like ours requires a number of resources to be implemented successfully, including money, hardware, equipment, supplies, etc. For this reason, we need to keep lines of communication open and efficient with the faculty, lab assistants, and other relevant authorities at Brac University. We satisfy the A2 criteria as a result.

Following this project's successful completion, the environment and society will be impacted, which is why we also need to complete the A4

For the project, we shall adhere to a number of procedures, guidelines, and standards. This technology has previously been the subject of extensive research, from which we have borrowed ideas for improving its efficiency, sustainability, and modernization. So, we satisfy the A5 criteria.

References

- [1]D. Alam, “The Problems of Public Transport in Dhaka - ICE Business Times,” *ICE Business Times*, Dec. 03, 2018. [Online]. Available: <https://ibtbd.net/the-problems-of-public-transport-in-dhaka/#:~:text=Buses%20and%20minibuses%20%E2%80%93%20the%20cheapest,that%20users%20confront%20every%20day.>
- [2]A. I. Mithu, “How the Mohakhali Bus Terminal keeps on creating traffic congestion,” *The Business Standard*, Jul. 02, 2022. [Online]. Available: <https://www.tbsnews.net/features/panorama/how-mohakhali-bus-terminal-keeps-creating-traffic-congestion-451426>
- [3]D. Alam, “The curious case of bus routes in Dhaka,” *The Daily Star*, Oct. 31, 2019. [Online]. Available: <https://www.thedailystar.net/star-weekend/city/news/the-curious-case-bus-routes-dhaka-1821229>
- [4]“Problems usually women face while travelling by public bus in Dhaka City,” *ResearchGate*. [Online]. Available: https://www.researchgate.net/figure/Problems-usually-women-face-while-travelling-by-public-bus-inDhaka-City_tb11_340807040
- [5]S. Nasrin and S. Sultana, “Operational Hazards of Bus Transportation in Dhaka Metro City,” *buetcse*, Sep. 05, 2016. [Online]. Available: https://www.academia.edu/28263917/Operational_Hazards_of_Bus_Transportation_in_Dhaka_Metro_City
- [6]S. M. Oishee, “Is public transport safe for women? | Dhaka Tribune,” *Dhaka Tribune*, Dec. 07, 2023. [Online]. Available: <https://www.dhakatribune.com/op-ed/2022/04/05/is-public-transport-safe-for-women>
- [7]D. Sun, “Women face trouble in public transport,” *daily-sun*, Jan. 01, 2024. [Online]. Available: <https://www.daily-sun.com/post/609094/Women-face-trouble-in-public-transport>
- [8]Kushal Gogri, “Real Time Bus Tracking System,” *ResearchGate*, Jun. 26, 2020. https://www.researchgate.net/publication/342483633_Real_Time_Bus_Tracking_System
- [9] M. Lab, “ESP32 Receive Data from Google Firebase with Example to Control Outputs,” *Microcontrollers Lab*, Aug. 21, 2023. [Online]. Available: <https://microcontrollerslab.com/google-firebase-control-esp32-outputs-arduino-ide/>
- [10]M. M. Rahman, “Real time Google map and Arduino based vehicle tracking system,” 2016. [Online]. Available: <https://www.semanticscholar.org/paper/Real-time-Google-map-and-Arduino-based-vehicle-Rahman-Mou/33c4cd761aeb71711cc5ef2450a87b1c1dece7e8>

[11] S. S. Naik, T. G. Harshitha, H. D. Spoorthy, B. S. Vedashree, G. S. S. Taj, and P. Vetrivelan, "IOT Based School Bus Monitoring System With Child Security," *Lecture notes on data engineering and communications technologies*, Jan. 01, 2020. [Online]. Available: https://doi.org/10.1007/978-3-030-37051-0_75

[12] "8 real time challenges faced day to day in school bus tracking!" [Online]. Available: <https://www.tracko.co.in/blog/school-bus-tracking-system/8-real-time-challenges-faced-day-to-day-in-school-bus-tracking>

Appendix

Logbooks:

FYDP (P) Spring 2023 Summary of Team Log Book/ Journal

Date/Time/Place	Attendee	Summary of meeting minutes	Responsible	Comment by ATC
05/02/23	1.Nushin 2.Anika 3.Maruf	Introduction	No task has been assigned yet	N/A as it was an introductory meeting
12/02/23	Nushin,Maruf,Zakir	1.Brainstorming about different topics 2.The problem needs to a real life complex engineering problem	Need to finalize the project problem	Bring more topics for discussion
19/02/23	Nushin, Maruf, Zakir	1.Need to finalize the problem statement 2.Need to finalize the objective 3.Need to finalize the requirements,specification, and constraints	Task-1: Nushin Task-2: Nushin Task-3: Nushin,Maruf and Zakir	1.Discussion Regarding Requirements 2.Discussion on Attributes of complex engineering problem 3.Overall Feedback of the presentation
26/02/23	Nushin, Anika, Maruf, Zakir	1.Need to improve the problem statement 2.To make the objective more precise 3.Need to correct the requirements,specifications and constraints	Task -1: Nushin,Maruf and Zakir Task-2: Zakir and Nushin Task-3: Nushin,Zakir,Anika and Maruf	Overall feedback on the report
05/03/23	Nushin, Anika, Zakir	1.Need to finalize all the design approaches 2.Need to finalize methodology	Task-1: Nushin and Anika Task-2: Nushin, Anika, Zakir	1.Discussion on design approaches(need to search for papers and articles) 2.Discussion on how the problem

				should be complex engineering problem
12/03/23	Nushin, Anika, Zakir	Need to correct flow charts and block diagrams	Task-1: Nushin, Zakir, Anika	Overall feedback of all the multiple design approaches
19/03/23	Nushin, Anika, Zakir	1. Need to correct the risk management 2. Need to finalize sustainability	Task-1: Maruf Task-2: Anika and Nushin Task-3: Zakir	Discussion on risk management, ethical consideration and overall estimated budget
26/03/23	Nushin, Anika, Zakir, Maruf	1. Need to finalize the safety consideration 2. Need to finalize the impact 3. Expected outcome	Task-1: Maruf Task-2: Anika Task-3: Nushin	Discussion on safety consideration and impact.
09/04/23	Nushin, Anika, Zakir	1. Need to correct the risk management 2. Need to finalize sustainability	Task-1: Nushin and Maruf Task-2: Anika and Maruf	Overall discussion on the final draft
16/04/23	Anika, Nushin, Zakir, Maruf	Mock presentation	No task has been assigned	Feedback on the presentation
26/04/23	Nushin, Anika, Maruf, Zakir	Project proposal report review	Task- Nushin, Anika, Maruf, Zakir	Feedback on the report

FYDP (D) Spring 2023 Summary of Team Log Book/ Journal

Date/Time/Place	Attendee	Summary of Meeting Minutes	Responsible	Comment by ATC
18/06/23	Nushin, Anika, Zakir, Maruf	software simulation discussion	Task - All	N/A
16/07/23	Nushin, Anika, Zakir	Software tool finalization	Task-All	Overall discussion
26/07/23	Nushin, Anika, Zakir, Maruf	Update and Mock Presentation	Task-All	1. Slides should be in proper format

				2. Need 3D modeling 3. Proteus simulation incomplete.
06/08/23	Nushin, Anika, Zakir,	Overall Update on the progress	Task-All	Overall Feedback given
13/08/23	Nushin, Anika, Zakir, Maruf	Update of the ticketing system and 3D modeling given	Task-all	N\A
20/08/23	Nushin, Anika, Zakir, Maruf	Update on modeling training and proteus simulation.	Task-All	Need more data for training
23/08/23	Nushin, Anika, Zakir, Maruf	final Mock Presentation	Task-All	1. Format of the slides needs to be changed. 2. Functional Requirements should be changed

FYDP (C) Spring 2023 Summary of Team Log Book/ Journal









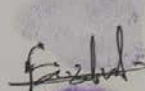

Date/Time/Place	Attendee	Summary of Meeting Minutes	Responsible	Comment by ATC
25/09/23	Nushin, Anika, Zakir, Maruf	Discussed about the progress of hardware implementation	Task - All	Approve of final components list
28/09/23	Nushin, Anika, Zakir, Maruf	Completing sensor synchronization	Task-All	
30/09/23	Nushin, Anika, Zakir, Maruf	Showed progress and data findings and taking preparation for progress presentation		Suggested to show the data in graph and suggested to make slides
12/10/23	Nushin, Anika, Zakir, Maruf	Working on Design efficiency and synthesizing code and data calculation.	Task-All	
16/10/23	Nushin, Anika, Zakir, Maruf	Collected data and findings and working on the efficiency	Task-All	

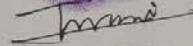
19/10/23	Nushin, Anika, Zakir, Maruf	Collected Data with different parameters	Task-All	
23/10/23	Nushin, Anika, Zakir, Maruf	Completed all the research and report Preparation	Task-All	
26/10/23	Nushin, Anika, Zakir, Maruf	Showed all data, graphs and designs	Task-All	give feedback on graphs and suggestions.
02/11/23	Nushin, Anika, Zakir, Maruf	Progress Presentation	Task-All	Receive feedback from other ATC panels.
06/11/23	Nushin, Anika, Zakir, Maruf	Overall Update on the progress	Task-All	Overall Feedback given
09/11/23	Nushin, Anika, Zakir, Maruf	Discussed about PCB design and final hardware design	Task-All	Suggested to do PCB design and give ideas about final hardware design.
13/11/23	Nushin, Anika, Zakir, Maruf	Working on Design efficiency and synthesizing code and data calculation.	Task-All	
16/11/23	Nushin, Anika, Zakir, Maruf	Collected data and findings and working on the efficiency	Task-All	
08/11/23	Nushin, Anika, Zakir, Maruf		Task-All	

Related code/theory/consent form

Consent Form:

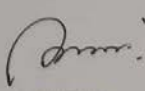
୧୫ ଓଗଷ୍ଟ, ୨୦୨୦
 ଶ୍ରୀ ଲକ୍ଷ୍ମୀ ବିଦ୍ୟାଳୟ ଯୋଜନା ଶିକ୍ଷା ପିଲାଙ୍କୁ ଉଦ୍ଦେଶ୍ୟ
 ଲାଭ କରିବା ପାଇଁ ଯୋଜନା ପ୍ରସ୍ତୁତ କରିବା ପାଇଁ ଆପଣଙ୍କର
 ସମ୍ମତ ଲାଭ କରିବା ପାଇଁ ଯୋଜନା କରାଯାଉଛି ।

ନାମ	ସ୍ୱାକ୍ଷର
ଶ୍ରୀ: ଉତ୍ତମ କାନ୍ତ	
ଶ୍ରୀ: ଉତ୍ତମ କାନ୍ତ	
ଶ୍ରୀ: ଉତ୍ତମ କାନ୍ତ	
ଶ୍ରୀ: ଉତ୍ତମ କାନ୍ତ	
ଶ୍ରୀ: ଉତ୍ତମ କାନ୍ତ	
ଶ୍ରୀ: ଉତ୍ତମ କାନ୍ତ	
ଶ୍ରୀ: ଉତ୍ତମ କାନ୍ତ	
ଶ୍ରୀ: ଉତ୍ତମ କାନ୍ତ	
ଶ୍ରୀ: ଉତ୍ତମ କାନ୍ତ	
ଶ୍ରୀ: ଉତ୍ତମ କାନ୍ତ	
ଶ୍ରୀ: ଉତ୍ତମ କାନ୍ତ	
ଶ୍ରୀ: ଉତ୍ତମ କାନ୍ତ	

code for people count using image processing

```
import cv2
import matplotlib.pyplot as plt
import cvlib as cv
```

```

import urllib.request
import numpy as np
from cvlib.object_detection import draw_bbox
import concurrent.futures
import serial
import time
from vidgear.gears import CamGear
import pyrebase

config = {
    "apiKey": "AIzaSyBx2q02qJQLfAZqgNSc01tIEaTZupCe_T8",
    "authDomain": "onetest-2710f.firebaseio.com",
    "databaseURL": "https://onetest-2710f-default-rtdb.asia-southeast1.firebaseio.com",
    "projectId": "onetest-2710f",
    "storageBucket": "onetest-2710f.appspot.com",
    "messagingSenderId": "1072590248238",
    "appId": "1:1072590248238:web:80dd41d254b54f2b15c2bf",
    "measurementId": "G-2BC0EDJSB0"
}

firebase=pyrebase.initialize_app(config)
db=firebase.database()

url='http://192.168.0.210/cam-hi.jpg'
im=None

def run1():
    cv2.namedWindow("live transmission", cv2.WINDOW_AUTOSIZE)
    while True:

```

```

img_resp=urllib.request.urlopen(url)
imgnp=np.array(bytearray(img_resp.read()),dtype=np.uint8)
im = cv2.imdecode(imgnp,-1)

cv2.imshow('live transmission',im)
key=cv2.waitKey(5)
if key==ord('q'):
    break

cv2.destroyAllWindows()

def run2():
    cv2.namedWindow("detection", cv2.WINDOW_AUTOSIZE)
    while True:
        img_resp=urllib.request.urlopen(url)
        imgnp=np.array(bytearray(img_resp.read()),dtype=np.uint8)
        im = cv2.imdecode(imgnp,-1)

        bbox, label, conf = cv.detect_common_objects(im)
        im = draw_bbox(im, bbox, label, conf)
        c=label.count('person')
        cv2.putText(im,str(c),(50,60),cv2.FONT_HERSHEY_PLAIN,3,(255,255,255),3)

        cv2.imshow('detection',im)
        data={"no_of_people" : c}
        db.child("People").update(data)
        key=cv2.waitKey(5)
        if key==ord('q'):
            break

```

```
cv2.destroyAllWindows()
```

```
if __name__ == '__main__':  
    print("started")  
    with concurrent.futures.ProcessPoolExecutor() as executor:  
        f1= executor.submit(run1)  
        f2= executor.submit(run2)
```

Website code homepage

```
import React, { useState, useEffect } from 'react'  
import { Link, useHistory, useLocation } from 'react-router-dom'  
import fire from '../files/firebase';  
import '../movie_details.css';
```

```
export const Homepage = () => {  
    const history = useHistory();  
    const location = useLocation();  
    const profile = location.state.profile;  
    const name = location.state.name;  
    const email = location.state.email;  
    const password = location.state.password;  
    const mobile = location.state.mobile;  
    const [moviedata, setmoviedata] = useState([]);
```

```

useEffect(() => {
  fire.firestore().collection("currentbuses").get().then((snapshot) => {
    snapshot.forEach(doc => {
      var data = doc.data();
      //console.log(data);
      setmoviedata(arr => [...arr, { data: data }])
    })
  })
  console.log(moviedata);
}, [])
return (
  <div className="wrapper ">
    <link href="../../assets/css/material-dashboard.css?v=2.1.2" rel="stylesheet" />
    <div className="sidebar" data-color="purple" data-background-color="white"
data-image="../../assets/img/sidebar-1.jpg">
      <Link to={{ pathname: "/homepage", state: { profile, name, email, password, mobile
} }} className="logo">
        <a className="simple-text logo-normal">
          EBUS
        </a>
      </Link>
    <div className="sidebar-wrapper">
      <ul className="nav">
        <li className="nav-item active ">
          <Link to={{ pathname: "/homepage", state: { profile: profile, name: name,
email: email, password: password, mobile: mobile } }} className="nav-link">
            <i className="material-icons">home</i>

```

```

        <p>Home</p>
    </Link>
</li>
<li className="nav-item">
    <Link to={{ pathname: "/dashboard", state: { profile: profile, name: name,
email: email, password: password, mobile: mobile } }} className="nav-link">
        <i className="material-icons">dashboard</i>
        <p>Dashboard</p>
    </Link>
</li>
<li className="nav-item ">
    <Link to={{ pathname: "/bookings", state: { profile: profile, name: name,
email: email, password: password, mobile: mobile } }} className="nav-link">
        <i className="material-icons">content_paste</i>
        <p>Bookings</p>
    </Link>
</li>
<li className="nav-item ">
    <Link to={{ pathname: "/userprofile", state: { profile: profile, name: name,
email: email, password: password, mobile: mobile } }} className="nav-link">
        <i className="material-icons">person</i>
        <p>User Profile</p>
    </Link>
</li>
<li className="nav-item ">
    <Link to={{ pathname: "/feedback", state: { profile: profile, name: name,
email: email, password: password, mobile: mobile } }} className="nav-link" >
        <i className="material-icons">notifications</i>
        <p>Feedback</p>
    </Link>
</li>

```



```

    <li className="nav-item ">
        <Link to={{ pathname: "/tracker", state: { profile: profile, name: name,
email: email, password: password, mobile: mobile } }} className="nav-link" >
            <i className="material-icons">track_changes</i>
            <p>Tracker</p>
        </Link>
    </li>
    <li className="nav-item ">
        <Link to="" className="nav-link" >
            <i className="material-icons">logout</i>
            <p>Logout</p>
        </Link>
    </li>
</ul>
</div>
</div>
<div className="main-panel">
    <nav class="navbar navbar-expand-lg navbar-transparent navbar-absolute fixed-top
">
        <div class="container-fluid">
            <div class="navbar-wrapper">
                <div>
                    <button class="navbar-toggler" type="button" data-toggle="collapse"
aria-controls="navigation-index" aria-expanded="false" aria-label="Toggle navigation">
                        <span class="sr-only">Toggle navigation</span>
                        <span class="navbar-toggler-icon icon-bar"></span>
                        <span class="navbar-toggler-icon icon-bar"></span>
                        <span class="navbar-toggler-icon icon-bar"></span>
                    </button>

```

```

    </div>
  </nav>

  <div className="row">
    {
      moviedata.map((data, index) => {
        //console.log(data.image);
        return <div className="col-4" key={index} style={{ marginLeft: "auto",
marginRight: "auto" }}>
          <div className="card">

            <div className="card-img-top img-fluid">
              <img src={data.data.image} style={{ width: '18rem', height: '20rem'
}} />
            </div>

            <button onClick={() => history.push({ pathname: "/details", state: {
route: data.data.routeurl, busname: data.data.busname, description: data.data.description,
attendantname: data.data.attendantname, attendantno: data.data.attendantno, releasedate:
data.data.releasedate, outdate: data.data.outdate, departuretime: data.data.departuretime,
arrivaltime: data.data.arrivaltime } })}>View Details</button>

            <button onClick={() => history.push({ pathname: "/bookingform",
state: { releasedate: data.data.releasedate, outdate: data.data.outdate, movieimage:
data.data.image, busname: data.data.busname, ticketcost: data.data.ticketcost, profile: profile,
name: name, email: email, password: password, mobile: mobile } })}>Book Now</button>

          </div>
        </div>
      })
    }
  </div>

```

```
    </div>
  </div>
</div>
```

```
)
}
```

Code for ESP 32 CAM:

```
#include "esp_camera.h"
#include <Arduino.h>
#include <WiFi.h>
#include <AsyncTCP.h>
#include <ESPAsyncWebServer.h>
#include <iostream>
#include <sstream>
#include <ESP32Servo.h>

#define PAN_PIN 14
#define TILT_PIN 15

Servo panServo;
Servo tiltServo;

struct MOTOR_PINS
{
```

```

int pinEn;
int pinIN1;
int pinIN2;
};

std::vector<MOTOR_PINS> motorPins =
{
    {2, 12, 13}, //RIGHT_MOTOR Pins (EnA, IN1, IN2)
    {2, 1, 3}, //LEFT_MOTOR Pins (EnB, IN3, IN4)
};

#define LIGHT_PIN 4

#define UP 1
#define DOWN 2
#define LEFT 3
#define RIGHT 4
#define STOP 0

#define RIGHT_MOTOR 0
#define LEFT_MOTOR 1

#define FORWARD 1
#define BACKWARD -1

const int PWMFreq = 1000; /* 1 KHz */
const int PWMResolution = 8;
const int PWMSpeedChannel = 2;
const int PWMLightChannel = 3;

```

```
//Camera related constants
#define PWDN_GPIO_NUM 32
#define RESET_GPIO_NUM -1
#define XCLK_GPIO_NUM 0
#define SIOD_GPIO_NUM 26
#define SIOC_GPIO_NUM 27
#define Y9_GPIO_NUM 35
#define Y8_GPIO_NUM 34
#define Y7_GPIO_NUM 39
#define Y6_GPIO_NUM 36
#define Y5_GPIO_NUM 21
#define Y4_GPIO_NUM 19
#define Y3_GPIO_NUM 18
#define Y2_GPIO_NUM 5
#define VSYNC_GPIO_NUM 25
#define HREF_GPIO_NUM 23
#define PCLK_GPIO_NUM 22
```

```
const char* ssid = "MyWiFiBus";
const char* password = "12345678";
```

```
AsyncWebServer server(80);
AsyncWebSocket wsCamera("/Camera");
AsyncWebSocket wsCarInput("/CarInput");
uint32_t cameraClientId = 0;
```

```
const char* htmlHomePage PROGMEM = R"HTMLHOMEPAGE(
<!DOCTYPE html>
<html>
```

```
<head>
```

```
<meta name="viewport" content="width=device-width, initial-scale=1, maximum-scale=1, user-scalable=no">
```

```
<style>
```

```
.arrows {
```

```
font-size:30px;
```

```
color:red;
```

```
}
```

```
td.button {
```

```
background-color:black;
```

```
border-radius:25%;
```

```
box-shadow: 5px 5px #888888;
```

```
}
```

```
td.button:active {
```

```
transform: translate(5px,5px);
```

```
box-shadow: none;
```

```
}
```

```
.noselect {
```

```
-webkit-touch-callout: none; /* iOS Safari */
```

```
-webkit-user-select: none; /* Safari */
```

```
-khtml-user-select: none; /* Konqueror HTML */
```

```
-moz-user-select: none; /* Firefox */
```

```
-ms-user-select: none; /* Internet Explorer/Edge */
```

```
user-select: none; /* Non-prefixed version, currently
```

```
supported by Chrome and Opera */
```

```
}
```

```
.slidecontainer {
```

```
width: 100%;  
}
```

```
.slider {  
  -webkit-appearance: none;  
  width: 100%;  
  height: 15px;  
  border-radius: 5px;  
  background: #d3d3d3;  
  outline: none;  
  opacity: 0.7;  
  -webkit-transition: .2s;  
  transition: opacity .2s;  
}
```

```
.slider:hover {  
  opacity: 1;  
}
```

```
.slider::-webkit-slider-thumb {  
  -webkit-appearance: none;  
  appearance: none;  
  width: 25px;  
  height: 25px;  
  border-radius: 50%;  
  background: red;  
  cursor: pointer;  
}
```

```

.slider::-moz-range-thumb {
    width: 25px;
    height: 25px;
    border-radius: 50%;
    background: red;
    cursor: pointer;
}

</style>

</head>

<body class="noselect" align="center" style="background-color:white">
    <table id="mainTable" style="width:400px;margin:auto;table-layout:fixed"
    CELLSPACING=10>
        <tr>
            <img id="cameraImage" src="" style="width:400px;height:250px"></td>
        </tr>
        <tr>
            <td></td>
            <td class="button" ontouchstart='sendButtonInput("MoveBus","1")'
            ontouchend='sendButtonInput("MoveBus","0")'><span class="arrows"
            >#8679;</span></td>
            <td></td>
        </tr>
        <tr>
            <td class="button" ontouchstart='sendButtonInput("MoveBus","3")'
            ontouchend='sendButtonInput("MoveBus","0")'><span class="arrows"
            >#8678;</span></td>
            <td class="button"></td>
            <td class="button" ontouchstart='sendButtonInput("MoveBus","4")'
            ontouchend='sendButtonInput("MoveBus","0")'><span class="arrows"
            >#8680;</span></td>
        </tr>
    </table>

```



```

</tr>
<tr>
  <td></td>
  <td class="button" ontouchstart='sendButtonInput("MoveBus","2")'
ontouchend='sendButtonInput("MoveBus","0")'><span
class="arrows"
>&#8681;</span></td>
  <td></td>
</tr>
<tr/><tr/>
<tr>
  <td style="text-align:left"><b>Speed:</b></td>
  <td colspan=2>
    <div class="slidecontainer">
      <input type="range" min="0" max="255" value="150" class="slider" id="Speed"
oninput='sendButtonInput("Speed",value)'>
    </div>
  </td>
</tr>
<tr>
  <td style="text-align:left"><b>Light:</b></td>
  <td colspan=2>
    <div class="slidecontainer">
      <input type="range" min="0" max="255" value="0" class="slider" id="Light"
oninput='sendButtonInput("Light",value)'>
    </div>
  </td>
</tr>
<tr>
  <td style="text-align:left"><b>Pan:</b></td>
  <td colspan=2>
    <div class="slidecontainer">

```

```

        <input type="range" min="0" max="180" value="90" class="slider" id="Pan"
oninput='sendButtonInput("Pan",value)'>
    </div>
</td>
</tr>
<tr>
    <td style="text-align:left"><b>Tilt:</b></td>
    <td colspan=2>
        <div class="slidecontainer">
            <input type="range" min="0" max="180" value="90" class="slider" id="Tilt"
oninput='sendButtonInput("Tilt",value)'>
        </div>
    </td>
</tr>
</table>

<script>
var websocketCameraUrl = "ws:\V" + window.location.hostname + "/Camera";
var websocketCarInputUrl = "ws:\V" + window.location.hostname + "/CarInput";
var websocketCamera;
var websocketCarInput;

function initCameraWebSocket()
{
    websocketCamera = new WebSocket(websocketCameraUrl);
    websocketCamera.binaryType = 'blob';
    websocketCamera.onopen = function(event){};
    websocketCamera.onclose = function(event){setTimeout(initCameraWebSocket,
2000)};
    websocketCamera.onmessage = function(event)

```

```

{
    var imageId = document.getElementById("cameraImage");
    imageId.src = URL.createObjectURL(event.data);
};
}

```

```
function initCarInputWebSocket()
```

```

{
    websocketCarInput = new WebSocket(webSocketCarInputUrl);
    websocketCarInput.onopen = function(event)
    {
        sendButtonInput("Speed", document.getElementById("Speed").value);
        sendButtonInput("Light", document.getElementById("Light").value);
        sendButtonInput("Pan", document.getElementById("Pan").value);
        sendButtonInput("Tilt", document.getElementById("Tilt").value);
    };

```

```

        websocketCarInput.onclose = function(event){setTimeout(initCarInputWebSocket,
2000)};

```

```

        websocketCarInput.onmessage = function(event){};
    }

```

```
function initWebSocket()
```

```

{
    initCameraWebSocket ();
    initCarInputWebSocket();
}

```

```
function sendButtonInput(key, value)
```

```

{

```

```

    var data = key + "," + value;
    websocketCarInput.send(data);
}

window.onload = initWebSocket;
document.getElementById("mainTable").addEventListener("touchend", function(event){
    event.preventDefault()
});
</script>
</body>
</html>
)HTMLHOMEPAGE";

```

```

void rotateMotor(int motorNumber, int motorDirection)
{
    if (motorDirection == FORWARD)
    {
        digitalWrite(motorPins[motorNumber].pinIN1, HIGH);
        digitalWrite(motorPins[motorNumber].pinIN2, LOW);
    }
    else if (motorDirection == BACKWARD)
    {
        digitalWrite(motorPins[motorNumber].pinIN1, LOW);
        digitalWrite(motorPins[motorNumber].pinIN2, HIGH);
    }
    else
    {
        digitalWrite(motorPins[motorNumber].pinIN1, LOW);
    }
}

```

```
    digitalWrite(motorPins[motorNumber].pinIN2, LOW);  
  }  
}
```

```
void moveCar(int inputValue)
```

```
{  
  Serial.printf("Got value as %d\n", inputValue);  
  switch(inputValue)  
  {  
  
    case UP:  
      rotateMotor(RIGHT_MOTOR, FORWARD);  
      rotateMotor(LEFT_MOTOR, FORWARD);  
      break;  
  
    case DOWN:  
      rotateMotor(RIGHT_MOTOR, BACKWARD);  
      rotateMotor(LEFT_MOTOR, BACKWARD);  
      break;  
  
    case LEFT:  
      rotateMotor(RIGHT_MOTOR, FORWARD);  
      rotateMotor(LEFT_MOTOR, BACKWARD);  
      break;  
  
    case RIGHT:  
      rotateMotor(RIGHT_MOTOR, BACKWARD);  
      rotateMotor(LEFT_MOTOR, FORWARD);  
      break;  
  }  
}
```

```
case STOP:
    rotateMotor(RIGHT_MOTOR, STOP);
    rotateMotor(LEFT_MOTOR, STOP);
    break;
```

```
default:
    rotateMotor(RIGHT_MOTOR, STOP);
    rotateMotor(LEFT_MOTOR, STOP);
    break;
```

```
}
```

```
}
```

```
void handleRoot(AsyncWebServerRequest *request)
```

```
{
```

```
    request->send_P(200, "text/html", htmlHomePage);
```

```
}
```

```
void handleNotFound(AsyncWebServerRequest *request)
```

```
{
```

```
    request->send(404, "text/plain", "File Not Found");
```

```
}
```

```
void onCarInputWebSocketEvent(AsyncWebSocket *server,
```

```
    AsyncWebSocketClient *client,
```

```
    AwsEventType type,
```

```
    void *arg,
```

```
    uint8_t *data,
```

```
    size_t len)
```

```

{
switch (type)
{
case WS_EVT_CONNECT:
    Serial.printf("WebSocket client #%u connected from %s\n", client->id(),
client->remoteIP().toString().c_str());
    break;
case WS_EVT_DISCONNECT:
    Serial.printf("WebSocket client #%u disconnected\n", client->id());
    moveCar(0);
    ledcWrite(PWMLightChannel, 0);
    panServo.write(90);
    tiltServo.write(90);
    break;
case WS_EVT_DATA:
    AwsFrameInfo *info;
    info = (AwsFrameInfo*)arg;
    if (info->final && info->index == 0 && info->len == len && info->opcode ==
WS_TEXT)
    {
        std::string myData = "";
        myData.assign((char *)data, len);
        std::istringstream ss(myData);
        std::string key, value;
        std::getline(ss, key, ',');
        std::getline(ss, value, ',');
        Serial.printf("Key [%s] Value[%s]\n", key.c_str(), value.c_str());
        int valueInt = atoi(value.c_str());
        if (key == "MoveCar")
        {

```

```

        moveCar(valueInt);
    }
    else if (key == "Speed")
    {
        ledcWrite(PWMSpeedChannel, valueInt);
    }
    else if (key == "Light")
    {
        ledcWrite(PWMLightChannel, valueInt);
    }
    else if (key == "Pan")
    {
        panServo.write(valueInt);
    }
    else if (key == "Tilt")
    {
        tiltServo.write(valueInt);
    }
}
break;
case WS_EVT_PONG:
case WS_EVT_ERROR:
    break;
default:
    break;
}
}

void onCameraWebSocketEvent(AsyncWebSocket *server,

```



```

        AsyncWebSocketClient *client,
        AwsEventType type,
        void *arg,
        uint8_t *data,
        size_t len)
{
    switch (type)
    {
        case WS_EVT_CONNECT:
            Serial.printf("WebSocket client #0%u connected from %s\n", client->id(),
client->remoteIP().toString().c_str());
            cameraClientId = client->id();
            break;
        case WS_EVT_DISCONNECT:
            Serial.printf("WebSocket client #0%u disconnected\n", client->id());
            cameraClientId = 0;
            break;
        case WS_EVT_DATA:
            break;
        case WS_EVT_PONG:
        case WS_EVT_ERROR:
            break;
        default:
            break;
    }
}

void setupCamera()
{

```

```

camera_config_t config;

config.ledc_channel = LEDC_CHANNEL_4;
config.ledc_timer = LEDC_TIMER_2;
config.pin_d0 = Y2_GPIO_NUM;
config.pin_d1 = Y3_GPIO_NUM;
config.pin_d2 = Y4_GPIO_NUM;
config.pin_d3 = Y5_GPIO_NUM;
config.pin_d4 = Y6_GPIO_NUM;
config.pin_d5 = Y7_GPIO_NUM;
config.pin_d6 = Y8_GPIO_NUM;
config.pin_d7 = Y9_GPIO_NUM;
config.pin_xclk = XCLK_GPIO_NUM;
config.pin_pclk = PCLK_GPIO_NUM;
config.pin_vsync = VSYNC_GPIO_NUM;
config.pin_href = HREF_GPIO_NUM;
config.pin_sscb_sda = SIOD_GPIO_NUM;
config.pin_sscb_scl = SIOC_GPIO_NUM;
config.pin_pwdn = PWDN_GPIO_NUM;
config.pin_reset = RESET_GPIO_NUM;
config.xclk_freq_hz = 20000000;
config.pixel_format = PIXFORMAT_JPEG;

config.frame_size = FRAMESIZE_VGA;
config.jpeg_quality = 10;
config.fb_count = 1;

// camera init
esp_err_t err = esp_camera_init(&config);
if (err != ESP_OK)

```

```

{
    Serial.printf("Camera init failed with error 0x%x", err);
    return;
}

if (psramFound())
{
    heap_caps_malloc_extmem_enable(20000);
    Serial.printf("PSRAM initialized. malloc to take memory from psram above this size");
}
}

void sendCameraPicture()
{
    if (cameraClientId == 0)
    {
        return;
    }

    unsigned long startTime1 = millis();
    //capture a frame
    camera_fb_t * fb = esp_camera_fb_get();
    if (!fb)
    {
        Serial.println("Frame buffer could not be acquired");
        return;
    }

    unsigned long startTime2 = millis();
    wsCamera.binary(cameraClientId, fb->buf, fb->len);
}

```

```

esp_camera_fb_return(fb);

//Wait for message to be delivered
while (true)
{
  AsyncWebSocketClient * clientPointer = wsCamera.client(cameraClientId);
  if (!clientPointer || !(clientPointer->queueIsFull()))
  {
    break;
  }
  delay(1);
}

unsigned long startTime3 = millis();

  Serial.printf("Time taken Total: %d|%d|%d\n",startTime3 - startTime1, startTime2 -
startTime1, startTime3-startTime2 );
}

void setUpPinModes()
{
  panServo.attach(PAN_PIN);
  tiltServo.attach(TILT_PIN);

  //Set up PWM
  ledcSetup(PWMSpeedChannel, PWMFreq, PWMResolution);
  ledcSetup(PWMLightChannel, PWMFreq, PWMResolution);

  for (int i = 0; i < motorPins.size(); i++)
  {

```

```

pinMode(motorPins[i].pinEn, OUTPUT);
pinMode(motorPins[i].pinIN1, OUTPUT);
pinMode(motorPins[i].pinIN2, OUTPUT);
/* Attach the PWM Channel to the motor enb Pin */
ledcAttachPin(motorPins[i].pinEn, PWMSpeedChannel);
}
moveCar(STOP);

pinMode(LIGHT_PIN, OUTPUT);
ledcAttachPin(LIGHT_PIN, PWMLightChannel);
}

void setup(void)
{
  setUpPinModes();
  //Serial.begin(115200);

  WiFi.softAP(ssid, password);
  IPAddress IP = WiFi.softAPIP();
  Serial.print("AP IP address: ");
  Serial.println(IP);

  server.on("/", HTTP_GET, handleRoot);
  server.onNotFound(handleNotFound);

  wsCamera.onEvent(onCameraWebSocketEvent);
  server.addHandler(&wsCamera);

```

```

wsCarInput.onEvent(onCarInputWebSocketEvent);
server.addHandler(&wsCarInput);

server.begin();
Serial.println("HTTP server started");

setupCamera();
}

void loop()
{
wsCamera.cleanupClients();
wsCarInput.cleanupClients();
sendCameraPicture();

Serial.printf("SPIRam Total heap %d, SPIRam Free Heap %d\n", ESP.getPsramSize(),
ESP.getFreePsram());
}

```

Code for the sensors:

```

#include <Adafruit_MPU6050.h>
#include <Adafruit_Sensor.h>
#include <Wire.h>
#include <LiquidCrystal_I2C.h>
Adafruit_MPU6050 mpu;
LiquidCrystal_I2C lcd(0x27, A4, A5);
#define TRIGGER_PIN_1 4
#define ECHO_PIN_1 5
#define TRIGGER_PIN_2 7

```

```

#define ECHO_PIN_2 6
#define TRIGGER_PIN_3 8
#define ECHO_PIN_3 9
#define TRIGGER_PIN_4 11
#define ECHO_PIN_4 10
int buzzer = A1, gas_s = A0;
int signal_pin = 3, signal_pin2 = A3, x;

void setup() {
  Serial.begin(115200);

  while (!Serial)
    delay(10); // will pause Zero, Leonardo, etc until serial console opens

  Serial.println("Adafruit MPU6050 test!");

  // Try to initialize!
  if (!mpu.begin()) {
    Serial.println("Failed to find MPU6050 chip");
    while (1) {
      delay(10);
    }
  }
  Serial.println("MPU6050 Found!");

  Serial.println("");
  delay(100);
  pinMode(TRIGGER_PIN_1, OUTPUT);
  pinMode(ECHO_PIN_1, INPUT);

```

```

pinMode(TRIGGER_PIN_2, OUTPUT);
pinMode(ECHO_PIN_2, INPUT);
pinMode(TRIGGER_PIN_3, OUTPUT);
pinMode(ECHO_PIN_3, INPUT);
pinMode(TRIGGER_PIN_4, OUTPUT);
pinMode(ECHO_PIN_4, INPUT);
pinMode(signal_pin, OUTPUT);
pinMode(signal_pin2, OUTPUT);
}

void loop() {
  sensors_event_t a, g, temp;
  mpu.getEvent(&a, &g, &temp);

  // Serial.print("Accelerometer ");
  // Serial.print("X: ");
  // Serial.print(a.acceleration.x, 1);
  // Serial.print(" m/s^2, ");
  // Serial.print("Y: ");
  // Serial.print(a.acceleration.y, 1);
  // Serial.print(" m/s^2, ");
  // Serial.print("Z: ");
  // Serial.print(a.acceleration.z, 1);
  // Serial.println(" m/s^2");

  if (a.acceleration.y > 9 || a.acceleration.y < -9) {
    Serial.println("Vibration Detected");
    digitalWrite(signal_pin2, HIGH);
    delay(1000);
  }
}

```



```

}

else {
    digitalWrite(signal_pin2, LOW);
}

unsigned long duration1, distance1;
unsigned long duration2, distance2;
unsigned long duration3, distance3;
unsigned long duration4, distance4;

// Sensor 1
digitalWrite(TRIGGER_PIN_1, LOW);
delayMicroseconds(2);
digitalWrite(TRIGGER_PIN_1, HIGH);
delayMicroseconds(10);
digitalWrite(TRIGGER_PIN_1, LOW);
duration1 = pulseIn(ECHO_PIN_1, HIGH);
distance1 = (duration1 / 2) / 29.1; // Convert to centimeters

// Sensor 2
digitalWrite(TRIGGER_PIN_2, LOW);
delayMicroseconds(2);
digitalWrite(TRIGGER_PIN_2, HIGH);
delayMicroseconds(10);
digitalWrite(TRIGGER_PIN_2, LOW);
duration2 = pulseIn(ECHO_PIN_2, HIGH);
distance2 = (duration2 / 2) / 29.1; // Convert to centimeters

```

```
// Sensor 3
digitalWrite(TRIGGER_PIN_3, LOW);
delayMicroseconds(2);
digitalWrite(TRIGGER_PIN_3, HIGH);
delayMicroseconds(10);
digitalWrite(TRIGGER_PIN_3, LOW);
duration3 = pulseIn(ECHO_PIN_3, HIGH);
distance3 = (duration3 / 2) / 29.1; // Convert to centimeters
```

```
// Sensor 4
digitalWrite(TRIGGER_PIN_4, LOW);
delayMicroseconds(2);
digitalWrite(TRIGGER_PIN_4, HIGH);
delayMicroseconds(10);
digitalWrite(TRIGGER_PIN_4, LOW);
duration4 = pulseIn(ECHO_PIN_4, HIGH);
distance4 = (duration4 / 2) / 29.1; // Convert to centimeters
```

```
Serial.print("Sensor 1: ");
Serial.print(distance1); // up
Serial.print(" cm\tSensor 2: ");
Serial.print(distance2); // up
Serial.print(" cm\tSensor 3: ");
Serial.print(distance3); // left
Serial.print(" cm\tSensor 4: ");
Serial.print(distance4); // right
Serial.println(" cm");
```

```
    if ((distance1 > 0 && distance1 < 15) || (distance2 > 0 && distance2 < 15) || (distance3 > 0
&& distance3 < 15) || (distance4 > 0 && distance4 < 15)) {
        x++;
    }

    else {
        digitalWrite(signal_pin, LOW);
        x = 0;
    }

    if (x > 5) {
        digitalWrite(signal_pin, HIGH);
    }

    Serial.println(x);
    //delay(50);

    delay(10);
}
```

