

# **DEVELOPMENT OF AN AUTOMATED GLOVE FOR POST STROKE HAND REHABILITATION**

By

Ashraf Shafayet Adittya

19121005

MD Fahin Fuad Irfa Chowdhury

19121003

Sajidul Islam

19121093

Salman Ahnaf

19121022

A Final Year Design Project (FYDP) submitted to the Department of Electrical and Electronic Engineering in partial fulfillment of the requirements for the degree of Bachelor of Science in Electrical and Electronic Engineering

Electrical and Electronic Engineering

Brac University

December 2022

© 2022. BRAC University

All rights reserved.

# **DEVELOPMENT OF AN AUTOMATED GLOVE FOR POST STROKE HAND REHABILITATION**

By

Ashraf Shafayet Adittyia

19121005

MD Fahin Fuad Irfa Chowdhury

19121003

Sajidul Islam

19121093

Salman Ahnaf

19121022

Academic Technical Committee (ATC) Panel Member:

Dr. A.S. Nazmul Huda (Chair)

Associate Professor, Department of EEE, BRAC University

Nahid Hossain Taz (Member)

Lecturer, Department of EEE, BRAC University

Raihana Shams Islam Antara (Member)

Lecturer, Department of EEE, BRAC University

© 2022. BRAC University

All rights reserved.

## **Declaration**

It is hereby declared that

1. The Final Year Design Project (FYDP) submitted is my/our own original work while completing degree at Brac University.
2. The Final Year Design Project (FYDP) does not contain material previously published or written by a third party, except where this is appropriately cited through full and accurate referencing.
3. The Final Year Design Project (FYDP) does not contain material which has been accepted, or submitted, for any other degree or diploma at a university or other institution.
4. I/We have acknowledged all main sources of help.

**Student's Full Name & Signature:**

---

**Ashraf Shafayet  
Aditya  
19121005**

---

**MD Fahin Fuad Irfa  
Chowdhury  
19121003**

---

**Sajidul Islam  
19121093**

---

**Salman Ahnaf  
19121022**

## Approval

The Final Year Design Project (FYDP) titled “Development of an Automated Glove for Post Stroke Hand Rehabilitation and Assistance” submitted by

1. Ashraf Shafayet Aditya (19121005)
2. MD Fahin Fuad Irfa Chowdhury (19121003)
3. Sajidul Islam (19121093)
4. Salman Ahnaf (19121022) of Fall 2022 has been accepted as satisfactory in partial fulfillment of the requirement for the degree of Bachelor of Science in Electrical and Electronic Engineering on 22<sup>nd</sup> December.

### Examining Committee:

Academic Technical  
Committee (ATC):  
(Chair)

---

Dr. A.S. Nazmul Huda  
Associate Professor, Department of EEE  
BRAC University

Final Year Design Project  
Coordination Committee:  
(Chair)

---

Dr. Abu S. M. Mohsin  
Associate Professor, Department of EEE  
BRAC University

Department Chair:

---

Dr. Md. Mosaddequr Rahman  
Professor and Chairperson, Department of EEE  
BRAC University

## **Ethics Statement**

We have followed and confined ourselves intricately to the ethical boundaries regarding our institution and the general public. Our team has aspired to perform and conduct honest, principled and ambitious work considering all rules and regulations set by our respected department. Vigorous research and considerations have been sought after based on the welfare of society and target audience.

## **Abstract**

Stroke being one of the foremost causes of paralysis and long-term impairment, has compelled people to live under restrictions and spend their lives poorly. Our project aims to help stroke victims regain the dexterity in their hands, allowing them to perform basic tasks such as grasping and releasing objects which are known as ADLs. High cost, portability and absence of rehabilitation devices were the project's main challenges. Our devised system targets to reduce the price, ensure portability, and most importantly, sow the seeds for innovation in automated rehabilitation because hand therapy devices are unavailable in our country and expensive imported devices are not practical for our general public. We have incorporated flex sensors, RF modules and metal gear servo motors for detection, transmission and movement. Furthermore, the Arduino micro controller can be identified as the heart of the system.

## **Acknowledgement**

We are earnestly thankful to Dr. A.S Nazmul Huda, our FYDP Coordinator and Assistant Professor in the Department of Electrical and Electronic engineering at BRAC University, for supervising us on our Final Year Design Project. His expertise and guidance along with the mentorship of Nahid Hossain Taz and Raihana Shams Islam Antara, Lecturer, in the Department of Electrical and Electronic engineering at BRAC University has enabled us to achieve our aspirations regarding our project.

## **Table of Contents**

Declaration	iii
Approval	iv
Ethics Statement	v
Abstract	vi
Acknowledgement	vii
List of Tables	xiii
List of Figures	xiv
List of Acronyms	xvi
Glossary	xvii
<b>Chapter 1: Introduction - [CO1, CO2, CO10]</b>	<b>1</b>
<b>1.1 Introduction</b>	<b>1</b>
<b>1.1.1 Problem Statement</b>	<b>1</b>
<b>1.1.2 Background Study</b>	<b>2</b>
<b>1.1.3 Literature Gap</b>	<b>2</b>
<b>1.1.4 Relevance to current and future Industry</b>	<b>3</b>
<b>1.2 Objectives, Requirements, Specification and constant</b>	<b>3</b>
<b>1.2.1. Objectives</b>	<b>4</b>
<b>1.2.2. Requirements</b>	<b>4</b>
<b>1.2.3. Specifications</b>	<b>6</b>



<b>1.2.4 Technical and Non-technical consideration and constraint in design process</b>	<b>7</b>
<b>1.2.5 Applicable compliance, standards, and codes</b>	<b>11</b>
<b>1.3 Systematic Overview/summary of the proposed project</b>	<b>13</b>
<b>1.4 Conclusion</b>	<b>13</b>
<b>Chapter 2: Project Design Approach [CO5, CO6]</b>	<b>14</b>
<b>2.1 Introduction</b>	<b>14</b>
<b>2.2 Identify multiple design approach</b>	<b>14</b>
<b>2.3 Describe multiple design approach</b>	<b>14</b>
<b>2.4 Analysis of multiple design approach</b>	<b>18</b>
<b>2.5 Conclusion</b>	<b>19</b>
<b>Chapter 3: Use of Modern Engineering and IT Tool. [CO9]</b>	<b>20</b>
<b>3.1 Introduction</b>	<b>20</b>
<b>3.2 Select appropriate engineering and IT tools</b>	<b>20</b>
<b>3.3 Use of modern engineering and IT tools</b>	<b>22</b>
<b>3.4 Conclusion</b>	<b>29</b>
<b>Chapter 4: Optimization of Multiple Design and Finding the Optimal Solution. [CO7]</b>	<b>30</b>
<b>4.1 Introduction</b>	<b>30</b>
<b>4.2 Optimization of multiple design approach</b>	<b>30</b>
<b>4.2.1 Utilize simulation software</b>	<b>30</b>

<b>4.2.2 Utilize rapid prototyping techniques</b>	34
<b>4.2.3 Utilize Design of Experiments (DOE)</b>	37
<b>4.2.4 Utilize user feedback</b>	38
<b>4.3 Identify optimal design approach</b>	38
<b>4.4 Performance evaluation of developed solution</b>	40
<b>4.5 Conclusion</b>	42
<b>Chapter 5: Completion of Final Design and Validation. [CO8]Error! Bookmark not defined.</b>	
<b>5.1 Introduction</b>	43
<b>5.2 Completion of final design</b>	43
<b>5.3 Evaluate the solution to meet desired need</b>	52
<b>Chapter 6: Impact Analysis and Project Sustainability. [CO3, CO4]</b>	53
<b>6.1 Introduction</b>	54
<b>6.2 Assessment of impact of the solution</b>	54
<b>6.2.1 Societal</b>	54
<b>6.2.2 Health</b>	55
<b>6.2.3 Safety</b>	55
<b>6.2.4 Legal</b>	56
<b>6.2.5 Cultural</b>	56
<b>6.3 Evaluate the sustainability</b>	57

<b>6.4 Conclusion</b>	58
<b>Chapter 7: Engineering Project Management. [CO11, CO14]</b>	58
<b>7.1 Introduction</b>	59
<b>7.2 Define, plan and manage engineering project</b>	59
<b>7.3 Evaluate project progress</b>	60
<b>7.4 Conclusion</b>	63
<b>Chapter 8: Economical Analysis. [CO12]</b>	64
<b>8.1 Introduction</b>	64
<b>8.2 Economic analysis</b>	64
<b>8.3 Cost benefit analysis</b>	65
<b>8.4 Evaluate economic and financial aspects</b>	66
<b>8.5 Conclusion</b>	67
<b>Chapter 9: Ethics and Professional Responsibilities CO13, CO2</b>	68
<b>9.1 Introduction</b>	68
<b>9.2 Identify ethical issues and professional responsibility</b>	68
<b>9.2.1 Social</b>	68
<b>9.2.2 Health</b>	69
<b>9.2.3 Legal</b>	69
<b>9.2.4 Cultural</b>	70
<b>9.3 Apply ethical issues and professional responsibility</b>	71

<b>9.4 Conclusion</b>	72
<b>Chapter 10: Conclusion and Future Work.</b>	73
<b>10.1 Project summary</b>	73
<b>10.2 Future work</b>	74
<b>Chapter 11: Identification of Complex Engineering Problems and Activities.</b>	77
<b>11.1: Identify the attribute of complex engineering problem (EP)</b>	77
<b>11.2: Provide reasoning how the project address selected attribute (EP)</b>	77
<b>11.3 Identify the attribute of complex engineering activities (EA)</b>	78
<b>11.4 Provide reasoning how the project address selected attribute (EA)</b>	78
<b>References</b>	80

**Appendix A.**  
**List of Tables**

Table 1.1: Component data table .....	06
Table 1.2: Standards and codes.....	12
Table 4.1: Comparison table of three multiple designs .....	39
Table 4.2: Delay time test .....	41
Table 7.1: Gantt chart .....	60
Table 7.2: Project progression breakdown.....	60
Table 8.1: Expected component price list and overall cost of the system .....	64
Table 8.2: Component price list and overall cost of the system .....	65

## List of Figures

Figure 2.1: System flow chart.....	15
Figure 2.2: Overview of the three-layered sliding spring mechanism [14] .....	16
Figure 2.3: (a) Dorsal side view of glove (b) Palm side view of rehabilitation glove [15] .....	17
Figure 2.4: Flexo-glove diagram: (a) Overall assembly (b) Finger actuation (c) Actuation unit [16].....	17
Figure 2.5: Pneumatic cylinder Simulink implementation .....	18
Figure 2.6: Pneumatic cylinder Simulink implementation .....	19
Figure 2.7: DC motor Simulink implementation .....	19
Figure 3.1: Block diagram and description of Controlled PWM Voltage .....	22
Figure 3.2: Block diagram and description of DC motor .....	23
Figure 3.3: Block diagram and description of H-Bridge .....	23
Figure 3.4: Whole system on the Simulink.....	24
Figure 3.5: Block diagram of linear actuator .....	24
Figure 3.6: Block diagram of parent and child circuit of motor driver.....	25
Figure 3.7: Block diagram of Speed and Current control subsystem.....	25
Figure 3.8: whole system on the Simulink.....	26
Figure 3.9: Block diagram and child circuit of double-acting Actuator .....	26
Figure 3.10: Block diagram and child circuit of 4-way Directional Valve .....	27
Figure 3.11: Whole system on the simulink .....	27
Figure 3.12: Designing 3D models of phalanges in solid works .....	28
Figure 3.13: Designing 3D models of forearms in solid works.....	28
Figure 3.14: Designing 3D models of palm in solid works .....	29
Figure 4.1: Load and spool position .....	31
Figure 4.2: Supply pipe pressure .....	31
Figure 4.3: Motor speed of the linear actuator.....	32
Figure 4.4: Current consumption by the DC motor .....	32
Figure 4.5: DC Motor Shaft Speed.....	41
Figure 4.6: Current Consumption by the DC motor.....	42
Figure 4.7: Using CAD software for 3D modelling.....	43
Figure 4.8: Mean finger length (in mm) for the index and ring fingers for males and females.....	49
Figure 4.9: New response time after hardware implementation.....	50
Figure 5.1: Assembling 3D printed parts.....	51
Figure 5.2: Assembling 3D printed parts.....	52
Figure 5.3: Mounting Servo Motors.....	53
Figure 5.4: Mounting Servo Motors.....	53

Figure 5.5: Placing flexi sensors on the unaffected hand glove.....54  
Figure 5.6: Flex sensor circuit for the control glove.....55  
Figure 5.7: Placing transmitter on the unaffected hand glove.....56  
Figure 5.8: Placing receiver on the affected hand glove.....56  
Figure 5.9: Arduino code for the transmitter side.....57  
Figure 5.10: Arduino code for the receiver side..... 57  
Figure 5.11: Final product after completing all steps.....57

## List of Acronyms

ADL	Activities of daily living
PWM	Pulse Width Modulation
DOF	Degrees of Freedom
ROI	Return on Investment



## **Glossary**

ADL

Activities of daily living include the regular motions of limbs required for daily survival work. For example, picking up objects, grabbing objects, walking distances etc.

PWM

The average strength of an electrical signal can be decreased by essentially cutting it up into discrete bits using pulse-width modulation, also known as pulse-duration modulation.

DOF

In physics, the degrees of freedom (DOF) of a mechanical system is the number of independent parameters that define its configuration or state.

ROI

A ratio between net income and investment is known as return on investment or return on costs. A high ROI indicates that the returns on the investment outweigh the costs.

## **Chapter 1: Introduction - [CO1, CO2, CO10]**

### **1.1 Introduction**

Engineering, according to the simplest of definitions, is the thoughtful process of finding a solution to complex problems. To add in technical terms, it is the branch of science and technology that concerns itself to unravel the complexities of real-world issues through designing, building, use of engines, machines, and structures etc. Hence, the underlying purpose of engineering problems is to resolve the real-life barriers that hold back mankind from evolution and advancement. The everso modern medical industry and impeccable medical knowledge of today is indebted to the modernization brought about by engineers and innovators. The current medical equipment which provides faultless data and ensure success of medical operations are the result of numerous years of experimentation and development made through engineering. Furthermore, robotics is now seen as the solution to many problems including medical physiotherapy. Unprivileged and poverty-stricken paralysis patients can find salvation in inexpensive automated devices which can aid them in returning normal functions of their limbs.

#### **1.1.1 Problem Statement**

Stroke is defined as the loss of brain cells as a result of a blood artery supplying the brain being blocked (ischemic stroke) or bleeding into or around the brain (hemorrhagic stroke) [1]. Stroke is a major cause of long-term impairments and can end in death or significant neurological damage. In accordance with 2007 estimates from the World Health Organization, 15 million people worldwide suffer from stroke each year [2]. According to studies, thanks to mindful healthcare practices, this number has decreased to 13 million [2]. Rehabilitation costs in the United States are around Tk.33 crores a year [1]. Stroke is a leading cause of morbidity and mortality, as well as a major socioeconomic issue [3]. This is especially true in emerging nations like Bangladesh where quality healthcare services such as therapeutic rehabilitation is out of reach of ordinary people. Due to the damage to neural structures, the majority of stroke survivors endure some amount of permanent hemiparesis or hemiplegia [3]. These individuals are unable to carry out everyday tasks on their own and must rely on human assistance for fundamental tasks such as food, self-care, and mobility.

In stroke patients, rehabilitation methods can help them regain neurological abilities, enhancing their quality of life [4]. Medical technology, particularly low-cost technology, can benefit the general public with rehabilitation and assistance. The growth and advancement of the medical technology industry demonstrates that, in the future, healthcare will be more reliant on technology or digitalization than traditional physiotherapy or rehabilitation procedures.

### **1.1.2 Background Study**

The current scarcity of therapists and caregivers for physically challenged people at home is projected to worsen and become a major issue in the near future. Recent research studies have found that robotic systems have the ability to solve this problem. Devices such as robotic exoskeletons of the hand and feet can enable patients to rehabilitate their limbs which are most affected by paralysis. However, these gadgets are only available in a few clinical settings, leaving lots of space for development. Although the majority of earlier studies and commercially available devices utilized a rigidly connected exoskeleton with plastic or fabric cushioning for hand contact [9], [10], contemporary research is focusing on softer, more sculpted materials. The quest for lighter, more comfortable gloves, as well as increased design flexibility, has led to this advancement.

In order to incorporate the required amenities to our system we must be skilled in modern engineering tools such as Proteus, Matlab and Solid Works. Proteus and Matlab are required for schematic design, simulation and testing of our project. On the other hand, Solid Works will provide us the opportunity to prepare 3D models of our gloves. Expertise regarding 3D printing is also required as we will be printing the exoskeleton of our gloves along with the outer shell of the control systems. Numerous materials such as linear actuators, pneumatic cylinder, servo and DC motors, flexi bending and pressure sensors, polylactic acid (PLA) filaments etc. are needed as construction materials. Arduino Uno is required as it will be the brain of the system. Other common materials include jumper wires, motor drivers, batteries etc. Resources for this project are from various sources. However, most of our equipment will be bought from comprehensive local websites where all robotics equipment is available. Knowledge on valuable guidelines and information regarding Arduino based systems can be found from various internet sources.

### **1.1.3 Literature Gap**

Many analogous devices have been developed in research facilities but are not commercially available [6]. To give structure, all of these devices use metal solid links that run parallel to each finger's proximal, intermediate, and distal phalanges. However, these devices are big and heavy, and they do not adjust well to individual differences in hand size. This is one of the most prevalent complaints regarding similar models. [7]. Furthermore, their large size, weight, and lack of mobility do not permit them to be utilized outside of clinical settings [8]. Because of this, modern research on hand rehabilitation and support systems concentrates on two main features: customization to fit various hand measurements and mobility to allow use outside of the hospital. Current research is concentrating on softer, more contoured materials, despite the fact that the bulk of prior experiments and commercially available devices used a rigidly linked exoskeleton with plastic or fabric cushioning for hand contact [9], [10]. This development is the result of the search for lighter, more comfortable gloves as well as more design options.

A glove made of polymers [11] was designed to aid individuals with spinal cord injuries with gripping motions considering the customizability feature. Another study presented a soft pneumatic assistance glove that is modular and adjustable [12]. Fabric-based gloves are also being used to construct similar devices [13]. Due to their hefty actuation systems, these gadgets are not easily portable. A comprehensive evaluation of existing hand rehabilitation devices reveals that each of them lacks one of the qualities listed above [6]. Even though current systems are relatively advanced and incorporate many features such as control systems and data acquisition protocols, there is still a significant need to improve efficiency and reduce cost of home-based devices for therapy and ADLs (Activities of Daily Living) assistance.

#### **1.1.4 Relevance to current and future Industry**

The expansion and development of the medical technology sector proves that technology or digitalization will play a larger role in healthcare in the future than conventional physiotherapy or rehabilitation techniques. The tremendous increase in digital therapeutics research over the last decade has resulted in the commercialization of evidence-based systems that are poised to disrupt healthcare markets in the coming decade [5]. As the usage of digital therapies for therapeutic purposes and market penetration grows, so does the potential to improve public health and lower healthcare costs.

Current designs include sensors, actuators, and control units used in advanced technology systems. These systems can be divided into two categories: (i) stationary systems and (ii) portable or wearable systems. SaebFlex, Bioness H200, and Hand of Hope are just a few of the rehabilitation and assistive systems that have been commercialized. But because of their size and weight, these gadgets are difficult to customize to different hand sizes. This is one of the most common criticisms of models such as this [7]. Additionally, they cannot be used outside of clinical settings due to their size, weight, and immobility [8]. Consequently, current research on hand rehabilitation and support systems is primarily focused on two aspects: customization to fit various hand measurements and mobility to allow use outside of hospitals for daily tasks, particularly as an assistive device. Recent research is concentrating on softer, more shaped materials. The development of an automated hand for post stroke hand rehabilitation and assistance is an important step in the treatment of paralyzed patients. This project is relevant to the current and future industry because it has the potential to improve patient care by reducing human error during rehabilitation, as well as making it easier for patients to perform tasks that they were able to do before their injuries occurred.

#### **1.2 Objectives, Requirements, Specification and constant**

Strokes and spinal cord injuries are the leading causes of paralysis and affect millions of people around the world. According to the Center for Disability in Development, approximately 16 million people in Bangladesh suffer from disabilities caused by various reasons. For this, robotic automation therapy can lessen this dependency on medical workers and therapists. Though developed rehabilitation devices are costly, and our nation is lagging behind in

digitalization in regards to therapy, there is a paramount potential for commercialization of automated rehabilitation devices.

### 1.2.1. Objectives

Therefore, our main goal is to create an automated hand rehabilitation and aid system, which is essentially a technologically advanced hand glove, so that patients with paralysis can autonomously circulate their paralyzed fingers and hands for physiological therapy.

Hence, the core objectives of our project are listed below,

- I. To develop an inexpensive hand rehabilitation and assistive device.
- II. To develop a portable hand rehabilitation device.
- III. To provide scope for an automated hand rehabilitation system originating in Bangladesh.

### 1.2.2. Requirements

Our main objective is to help injured people who need hand rehabilitation on one side of their body. Because many strokes result in hemiparesis, we intend to build a system that is managed by commands from the unaffected side of the body.

#### **Functional requirements:**

- I. ***Automated assistive hand movement*** – A wearable glove that manages finger movements steadily and comfortably. Additionally, after completing a therapy session, this glove should record the overall workout time and the number of cycles that were accomplished. So, the most significant goal of this endeavor is to restore the nervous system of a paralyzed hand. Finally, the glove should be easy to use and maintain. It should be able to be quickly and easily put on and taken off, as well as cleaned and disinfected after each use. It should also be
- II. ***Minimum pinch force 20 N*** – When the gloves grasp something, they must sustain a minimum pinch force of 20 N in order to be approved as an assistive hand device. This stipulation will guarantee that items that we use on a daily basis can be lifted and dropped precisely. If it doesn't do that, paralyzed patients may find it challenging to utilize it on a daily basis and that will hamper our project goal.
- III. ***3D printed or synthetic body*** – Comfortability of the user should always be the first priority. In order to do that the gloves should be made by a 3D printer where materials are soft plastic. In 3D printing, materials such as plastic, composites, or biomaterials are layered to form objects that vary in size, shape, rigidity, and color. Since the glove's main body is made of synthetic rubber, donning and doffing is comfortable for the wearer. Finally, the glove should be easy to clean and maintain. The material should be resistant to stains and easy to wipe down, so that the user can keep it hygienic.

**IV. Mechanical structure** – Our intended audience, which includes people of all ages and socioeconomic backgrounds, should find it simple to use. The glove should be 7.6 inches long and 3.5 inches wide, made of soft material that is flexible to fit users of all sizes. (i.e TPU filament plastic). Additionally, the glove should be lightweight and easily transportable, making it easy to take with you on the go. The glove should also be durable, able to withstand frequent use without showing signs of wear and tear.

**Non-functional requirements:**

**I. Easier maintenance** – This device should be simple to maintain so that users can start using it immediately after reading the usability instructions. The operations of the glove should be simple enough so that users from all ages and classes are able to use it with ease. Since we are targeting the Bangladeshi general mass as our prospective users, we ought to keep in mind that the majority of our target audience might be uneducated. Hence, it is important to keep the instruction manual brief, readable, non-technical and easy. One such way of ensuring easier usage is keeping the number of buttons in the interface limited. Limited number buttons mean less complexity for users. In the case of an emergency, we may also need a failsafe button for the immediate termination of exercising routines. For example, users can stop exercising routines almost immediately if they experience pain by the simple press of a button.

**II. Statistics and security** – The system should incorporate an app containing various statistics about exercise schedules, exercise time, progress of development. Patients should be able to view their weekly fitness schedule and keep track of exercising hours. The data from exercising routines can be compared with a set standard so that they are also able to keep track of their development. For reasons of security, we have determined that the glove's maximum grip force of 200 to 200 newtons should not be exceeded because it could endanger the user. Subsequently, a pressure sensor will enable the system to induce such a safety feature.

**III. Eco friendly** – Our system by nature is eco-friendly because it uses no amount of fossil fuels. Moreover, wastage is minimal since it will not require frequently changeable materials. To minimize the use of batteries, there will be an option for rectification to make our system environmentally friendly. Because, lithium-ion batteries often need to be replaced frequently, and their disposal is an environmental concern. Hence, the system shall work even when plugged into the power sources available in homes that provide AC power. To do this, it shall implement a converter that converts AC to DC current similar to all electronic appliances found in homes.

### 1.2.3. Specifications

Table 1.1: Component data table

Component	Specifications
Battery 18650	Voltage: 3.7V Capacity: 3800mAh Weight: 50gm Dimension: 8 × 3 × 2.5 cm Operating Temperature Range: -20°C to 60°C
Microcontroller (Arduino Uno)	Model type: UNO Rev R3 Input Voltage (recommended): 7-12V Digital I/O Pins: 14 (of which 6 provide PWM output) Analog Input Pins: 6 Operating Voltage: 5 V DC PWM Digital I/O Pins: 6 Dimensions (mm): LxWxH: 75x54x12 mm Weight (gm): 28 gm
Glove (3D printed)	Length: 7.6in (193.04mm) Width: 3.5in (88.9mm)
MG996R Servo Motor(5x) 180 Degree Rotation	Weight: 50g (+ -) Dimension: 40.7×19.7×42.9mm Operating voltage range: 4.8 V to 7.2 V Stall torque: 9.4kg/cm (4.8v); 11kg/cm (6v) Operating speed: 0.2 s/60° (4.8 V), 0.16 s/60° (6 V) Dead band width: 5 μs Operating temperature range: 0°C to +55°C Current draw at idle: 10mA No load operating current draw: 170mA Current at maximum load: 1200mA
Jumper Wire	Length of Cable (mm): 165.1 Weight (Gm): 5

2.2 Inch Flex Sensor	Flex length(mm): 2.2"(56) Total Length (cm): 7 Life Cycle : > 1 Million Flat resistance : 10K Ohms ±30% Bend Resistance : minimum 20K Ohms ±30% (@ 180° pinch bend) Power Rating : 0.5 Watts continuous; 1 Watt Peak.
RF Transmitter	Operating voltage: 3-12V Operating frequency: 433.92MHz; 315Mhz Standby current: 0mA Operating current :20-28mA Transmission distance: > 500m (open to receiving plate sensitivity at-103dBm distance of more than) Output Power: 16dBm (40mW) Transfer rate: <10Kbps Modulation mode: OOK (Amplitude Modulation) Operating Temperature: -10 °C ~ +70 °C Size: 19 × 19 × 8mm
RF Receiver Module	Operation voltage: DC5V Static Current: 4MA Receiver frequency: 433.92MHZ; 315 Mhz Sensitivity : - 105DB Dimension : 30*14*9mm External Antenna : 32CM signal wire, spiral

#### 1.2.4 Technical and Non-technical consideration and constraint in design process

##### Technical Considerations:

To start with, we can categorize the entire system into two subsystems i.e i) Control Unit and ii) Functioning Unit. The Control unit mainly consists of a Arduino UNO, RF transmitter, Batteries and flex sensors. On the other hand, the functioning unit contains another Arduino UNO, MG996R servo motors, a RF receiver, a 12V AC-DC adapter and DC-DC buck power module, 3D printed exoskeleton and a makeshift antenna.

The primary objective of this project is to provide rehabilitation through physiotherapy exercises to the patient. In order to do so, we needed a rigid exoskeleton of the hand that not only supports the weight of the hand but also creates enough force to move the fingers independently for the sake of exercise. Consequently, we selected a PLA filament-based 3D



printed hand for the task. We performed 3D design and alignments in SOLIDWORKS. Next, to operate considering the weight of the hand and fingers we chose MG996R high duty servo motors with 180° rotation that can withstand 10 Kg worth of weights or around a 100 N force. The high duty performance is due to the metal gears of the servo motors. To control this subsystem, we used an Arduino UNO. However, the high duty servo requires a great amount of current which puts pressure on the arduino. Hence, the DC-DC buck power module is used to supply both the Arduino and the 5 servo system. This buck power module is set to provide a 5.3 V supply to the system considering losses due to wires and heat.

On the contrary, comes the control unit subsystem that sends the position of the fingers from the healthy hand that will exercise the paralyzed hand accordingly. To do so, we fitted 5 flex sensors to each of the fingers along the proximal, intermediate, and distal phalanges. These sensors provide data to the Arduino that sends the signal to the functioning unit also known as the 3D printed hand unit. The control subsystem is powered through two 3.7 V batteries providing a total of 7.4V to the system. Calibration of the sensors is required at initialization of the subsystem. We set the control unit to calibrate 4 times before transmitting signals. Calibration is needed to identify the highest and lowest values of the sensors.

Furthermore, to incorporate wireless communication between the two subsystems, we used a RF module of 433 MHz. The transmitter was implemented at the control unit and the receiver was installed at the functioning unit. Additionally, for better transmission a 433 MHz gold plated spring antenna was used. However, for the receiver end we made a makeshift antenna out of a 17.31 cm copper wire due to shortage of components.

### **Non-technical Considerations:**

The non-technical considerations for this project mainly consist of multiple factors such as environmental, societal, cultural, legal, safety, health, ethical and sustainability. This initiative will have a significant influence on society because it is primarily intended for Bangladesh's impoverished people. Low-income families will not be able to participate in the pricey medical rehabilitation gadgets that wealthy people may purchase. They can get the affordable medical care they need thanks to our programme. We have stated that lowering the price of the gadget is our top priority, since doing so will raise the medical standards of a population made up mostly of disadvantaged individuals. When further developed, this technology will automate society's rehabilitation processes on its own, greatly advancing the digitization of our country. Additionally, by doing this, the rural residents of our nation will get familiar with contemporary healthcare systems. Additionally, thanks to this technology, the rural residents of our nation will become familiar with contemporary healthcare systems, which will contribute to the development of a younger population that is more informed and concerned. Our culture will become more insatiable for such inventions as a result of exposure to automation, which will set off a chain reaction that leads to numerous technological advancements. All systems must also be further adjusted in accordance with the requirements of their users.

Technically speaking, we will be able to obtain a lot more crucial information when our system is put on the market for the general public, which will help us update our equipment. For instance, consumers can discover a need for servo motors that respond more quickly so that they can perform intense exercise programs. So, we will need to improve our project accordingly. This project's only objective is to automate medical therapy and rehabilitation operations. In fact, the purpose of this gadget is to enhance the health of its users. Our invention will assist paralysis sufferers regain use of their paralyzed hand, which will undoubtedly enhance their health and quality of life. Additionally, it will lessen reliance on human interactions and mistakes. Our device will also be resourceful and time-effective. A patient won't have to waste time commuting to therapeutic facilities and standing in lines, for example. In physiotherapy facilities, there are few doctors caring for a vastly greater number of patients, which causes lengthier waiting times for very brief therapy sessions. Additionally, these physiotherapy treatments typically bill by the hour or per session, which results in ongoing expenses for the patients. Our solution will guarantee ease, time efficiency, and cost effectiveness for the clients from the very beginning as a single investment. One of the key standards to focus on throughout creation is the safety of an electronic gadget. The more digital a gadget is, the greater the hazards it poses. Any technical challenge involving safety and security requires extensive testing prior to introduction to the market.

In reality, the fundamental tenet of engineering is that projects succeed through a process of trial and error. To be commercialized, the project also has to prioritize safety measures. The gadget will face a lot of criticism if the security of customers and patients cannot be guaranteed. Its flaws and lack of safety will create unwanted attention, which will hurt its marketability. Additionally, safety issues and mishaps may result in legal issues for us and our project. When creating a system for general use, legal concerns must be included since the creators, or the manufacturer might be held accountable if undesirable or unforeseen events take place. Additionally, laws are crucial to ensuring customer safety. System failures such as overheating, damaged components, system instability, and a variety of other factors can result in accidents. The user may hold the supplier accountable if any failures cause an accident for them and they suffer injury. In severe circumstances, users may also submit cases including criminal charges, damage, and compensation lawsuits, etc. Therefore, as we create this product, we must address these systematic difficulties and offer a variety of disclaimers.

As time goes on, the medical culture depends more and more on technology. Our proposal would greatly diversify the medical industry in Bangladesh by encouraging medical innovation for the benefit of our people. Despite the fact that current technology has destroyed our traditional ways of carrying out various tasks, these sorts of activities are becoming more efficient and convenient. Furthermore, as automated technologies improve in availability and dependability, this system will have an effect on not just the medical culture but also the culture of the entire country. Everyone will desire automation in all facets of life. We must make sure a lot of things for our project to be sustainable, including its capacity to be recycled, durability, dependability, safety, etc.

Our system will be somewhat recyclable, if not entirely. Plastic materials, which can be recycled, make up the vast bulk of the components. The MG996 servo motors' metal gears may also be recycled. Additionally, we must make sure the equipment is trustworthy and long-lasting. In order to ensure sustainability, the gadget should have a long lifespan so that less materials are required for replacement. This is indifferent to nature and the environment, like any other gadgets, which will hurt the environment to some extent but may be repaired by careful eco-friendliness. Additionally, our product aims to enhance user health and mobilize a huge number of individuals who might otherwise be paralyzed. Many individuals can become aware of the damage that has been done to the environment for their development if the right incentive is provided along with the technology. Additionally, products may be reused rather than being destroyed thanks to the device's repair services.

### **Constraints:**

- I. Consumer type** - The majority of people in Bangladesh live in poverty. Therefore, we must consider the reasonable price bracket and develop accordingly. Furthermore, the system needs to be durable, and its lifespan must be lengthy to accommodate the fact that our targeted consumers may not be able to buy the product frequently. Our aim should be to develop a system that shall terminate only after achieving its core purpose which is rehabilitation of paralysis. So
- II. Mechanical type** - The system has a fairly significant risk of failure due to the sheer number of tiny moving mechanical parts. It would be challenging to place every sensitive component on the palm of a hand because the system as a whole has a smaller physical space than most of the project. Additionally, the use of redundant components, such as additional sensors and controllers, can help further reduce the risk of failure.
- III. Precision type** - Maintaining precision while assisting patients in a rehabilitation system is important since hand sizes vary widely, and the mechanism may require exact customization. For example, if a therapist is helping a patient to practice a particular movement or exercise, they must ensure that the adjustment settings are precise and accurate. This ensures that the patient is getting the correct amount of resistance or assistance, helping them to progress in their rehabilitation effectively. It also reduces the risk of injury, as incorrect settings could lead to incorrect use of the system.
- IV. Assistive type** - We must test the system to improve our work before completing our project. However, due to commercialism, health clinics might not work with us in this situation. Additionally, managing patients to test our newly built equipment is a challenging task. Alternatively, we could reach out to different organizations, such as independent research centers, to see if they would be willing to collaborate with us on the project. This could potentially give us access to resources and personnel that could help us test the system. Overall, there are a few approaches that we could take to test the system without involving external parties. However, depending on the resources

available and the level of accuracy we need, one option may be more suitable than others.

**V. Budget** - While working on the hardware prototype, we faced a challenge on our project budget because there are some components that are not available in our country. Therefore, we needed to spend more on some components that we alternatively used. Moreover, 3d design needs precision but because of the beginner stage, our first design could not meet up our expected outcome, so some extra expense went through on the second 3d print.

**VI. Transmission type** - There was a shortage of components that compelled us to build a makeshift antenna out of copper wire. According to  $V = f\lambda$ , where  $\lambda$  is the wavelength,  $f$  is the frequency of the RF transmitter and  $c$  is light speed. We get wire length by dividing  $\lambda$  by 4. We got the idea from open-source platform YouTube. We learned a lot about RF antennas and the principles of radio frequency engineering during this experiment.

$$\begin{aligned}\Rightarrow v &= f\lambda \\ \Rightarrow \lambda &= v/f \\ \Rightarrow \lambda &= 3 \times 10^8 / 433 \times 10^6 \\ \Rightarrow \lambda &\cong 0.6928\end{aligned}$$

Now,

$$\begin{aligned}L &= \lambda/4 \\ \Rightarrow L &= 0.6928/4 \\ \Rightarrow L &= 0.1732\text{ m}\end{aligned}$$

$\therefore$  The length of the wire must be 17.32 cm

### 1.2.5 Applicable compliance, standards, and codes

Since we are trying to develop an automated post-stroke hand rehabilitation and assistive device in a very low budget which is a medical technology for the healthcare industry, we have to follow different kinds of protocols. Firstly, we must follow the ISO (International Organization for Standardization) published standards for medical devices.

Table 1.2: Standards and codes

Standards	Definition
ISO 13485	Specifies requirements for a quality management system where an organization needs to demonstrate its ability to provide medical devices and related services that consistently meet customer and applicable regulatory requirements.
ISO 14971	Assist manufacturers of medical devices to identify the hazards associated with the medical device, to estimate and evaluate the associated risks, to control these risks, and to monitor the effectiveness of the controls.
ISO 62304	The set of processes, activities, and tasks described in this standard establishes a common framework for medical device software life cycle processes.
ISO 15223	These symbols can be used on the medical device itself, on its packaging or in the accompanying information.
ISO 11783	Standardize the method and format of data transfer between sensors, actuators, control elements, display.
ISO 21420	This document specifies the general requirements and relevant test procedures for glove design and construction.
ISO 12405	Specifies standard test procedures for basic characteristics of performance, reliability and abuse of lithium-ion battery packs and systems.
IEC 60227	Rigid and flexible cables with insulation, and sheath if any, based on polyvinyl chloride.
IEC 60502	Construction, dimensions, and test requirements of power cables with extruded solid insulation.
IEC 60331	Specifies the test method for cables which are required to maintain circuit integrity when subject to fire and mechanical shock under specified conditions.
IEEE 1419	This standard covers minimum labeling, performance, and safety requirements for automatic or semi-automatic (advisory) external defibrillators (AED), remote control defibrillators (RCD), and self-adhesive combination electrodes.

As the semi-automatic post stroke rehabilitation glove is still new hence, already

implemented standards need a fine tuning with the project.

### **1.3 Systematic Overview/summary of the proposed project**

Stroke being a major socio-economic challenge, particularly for Bangladesh, has compelled our project to endorse automation and robotics. The project's primary obstacles were the high cost and unavailability of such rehabilitation devices, along with required components or resources. Since devices for hand therapy are unavailable in our country and imported devices cost a tremendous amount, our system needs to downsize the cost, to ensure portability and most importantly incorporate assistive functions. Henceforth, one of our main purposes is to progress and automate the physiotherapy industry and to familiarize ourselves with these types of modern devices in our country. To build this project, we considered three different designs and after analyzing the data from our simulations, we came to the conclusion that our "3D printed soft exoskeleton with micro-DC motor" is appropriate to work with when we develop our prototype. Because of the soft plastic material, we are using, this design will be comfortable for the user. Moreover, the control system of this whole unit is comparatively easier because the micro-DC motor is not very complicated to control. We chose modern simulation tools to get a response from our system designs and to help us analyze future progress in order to achieve our systematic goals. MATLAB showed us the output responses to verify our system. Observable is that designs which are based on "pneumatic bending actuator" and "slide spring mechanism" sometimes give unwanted current spikes after given input, which we noticed in our MATLAB simulation. On the other hand, the "DC motor with 3D printed" design is not that irregular when it gives a response, and because of that, this design is our first choice. Making a cost-effective and efficient device is very challenging. Firstly, some components are not available in our country. As a result, we must modify some of our systems' designs in order to reduce our costs. Moreover, we replaced some of the components with some other efficient components to make the device more flexible and precise. Besides, our project may be the best replacement of physiotherapy and can also help prevent many side effects from available kinds of stroke therapy (electroacupuncture) on the basis of usability and expert recommendation. Moreover, we developed the system by taking all kinds of ethics and safety features into our concern.

### **1.4 Conclusion**

The device, being compact and inexpensive, will be a savior to the needful people of Bangladesh. It will ensure cost friendly physiotherapy and reliability. Furthermore, our system is also projected at instigating innovation for more automated medical equipment production in our country. A sustainable and reliable gadget such as our hand rehabilitation device will procure the trust of the people of our nation in our own manufactured electronics. Additionally, a major change in how people partake in physiotherapy can be expected on a longer vision for this project.

## **Chapter 2: Project Design Approach [CO5, CO6]**

### **2.1 Introduction**

A hand rehabilitation project for stroke patients is an excellent way to improve the function and quality of life for those who have suffered a stroke. This type of project can involve many different types of therapies and activities, all of which are designed to help the patient regain as much function in their hand as possible. Many times, patients who participate in a hand rehabilitation project see a significant improvement in their ability to perform everyday tasks, as well as an overall improvement in their quality of life. For this project, we have considered three multiple designs to assess the core functionality of the project in three different ways.

### **2.2 Identify multiple design approach**

The design approach for the rehabilitation device has three main objectives. The first objective is to reduce the frequency of the need for surgical intervention by increasing the patient's ability to perform a range of tasks. The second objective is to reduce the cost associated with surgical intervention by decreasing the need for expensive hardware and costly prostheses. The third objective is to improve patient satisfaction by providing a rehabilitation device which is easy to use, durable, and accessible.

The core part of this project is the actuation unit. After going through various research papers we identified three major types of actuation systems which are pneumatically driven, DC motor driven, and linear actuator driven. However, further follow up research has been conducted to select three designs which consist of these three actuation systems.

Another requirement for this project is to have a device that is lightweight and portable. The device should also be designed in such a way that it can be easily carried by patients when they leave the hospital. Moreover, the device should not be bulky and heavy, and it still provides the necessary amount of support for the patient.

Keeping these things in mind we selected our three designs which will be addressing all the above-mentioned criteria and they are as follows,

Design 1: Using three-layered sliding spring mechanism [14]

Design 2: Using pneumatic cylinder and bending actuator [15]

Design 3: Using 3D printed soft exoskeleton [16]

### **2.3 Describe multiple design approach**

Regardless of what kind of actuation mechanism our device uses, the basic working principle of both design 1 and design 2 are the same. For this reason, we tried to give a visual intuition

by creating one single flowchart. The microcontroller gets data from the sensors (i.e., pressure sensor, position sensor) and based on that data it either controls the proportional valves or the DC motors to control the spools through the control unit. Although there are a lot of other features, we are interested in integrating with this device, but the main working principle is the same. The flowchart below represents the system which gives a better visualization of the working principle. The power source is a LiPo battery which supplies all the power required by the system. The microcontroller analyzes the data from the sensors and depending on that data, it controls the actuator and proportional valves to extend or compress the fingers via the control unit. It is a closed loop process which keeps on sending and receiving data as long as the power is on.

In design 3 however, there is no actuator or pneumatic cylinder and instead there are four micro-DC motors which do the task of the actuator.

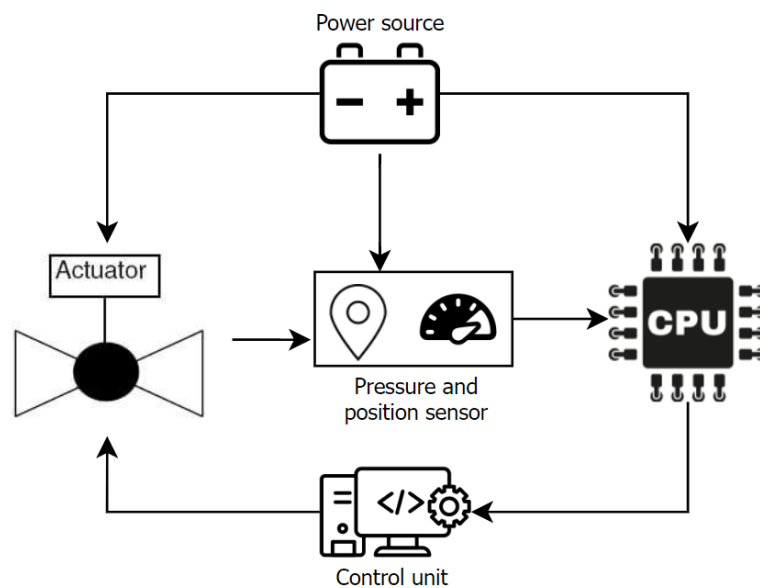

Figure 2.1. System flow chart

Although the basic principle of these three designs are the same, which is to move the fingers, they have their own distinguishable characteristics as well. A brief description of these multiple designs has been provided below.

### A. Using three-layered sliding spring mechanism [14]

In this design, a three-layered sliding spring mechanism has been used which causes the finger movements. A human finger usually has 3 segments. With the help of this design, three sliding springs will cause these individual segments of the fingers to move by distributing 1-DOF actuated linear motion into three rotational motions of the finger joint [14]. To minimize the complexity of the system, only one actuator is used. This will make the system compact, lightweight and in addition to that, the four fingers can be actuated simultaneously. The main focus of this design is that it is based on a compliant mechanism. In short, a compliant mechanism consists of one or more elastic structures which deform to transform the power in place of conventional revolute joints [14].



The advantages of compliant mechanism are,

1. It does not require any backlash or lubricant.
2. Free from any mechanical noise.
3. Compact and lightweight

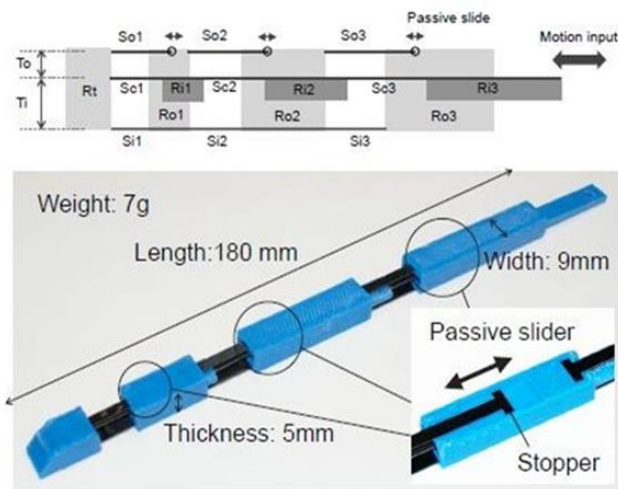

Figure 2.2 Overview of the three-layered sliding spring mechanism [14]

## B. Using pneumatic cylinder and bending actuator [15]

In this design mechanism, a pneumatic cylinder, bending actuator has been used to build the device. This design offers both a rehabilitation system as well as a robotic arm for grasping objects which makes it versatile. In this device, all the five fingers can be controlled independently unlike the other two designs with isolated valves and the input pressure is regulated by a proportional valve [15]. Each finger in the glove is also equipped with force sensors and bending actuators to measure the pressure force at fingertip and to record the angular displacement of the corresponding MCP joint [15]

The advantages of design using bending actuator are,

1. It offers high flexibility.
2. Low impedance and stiffness.
3. Good wearability.
4. Outstanding lightness and low profile to interface with the human hand.

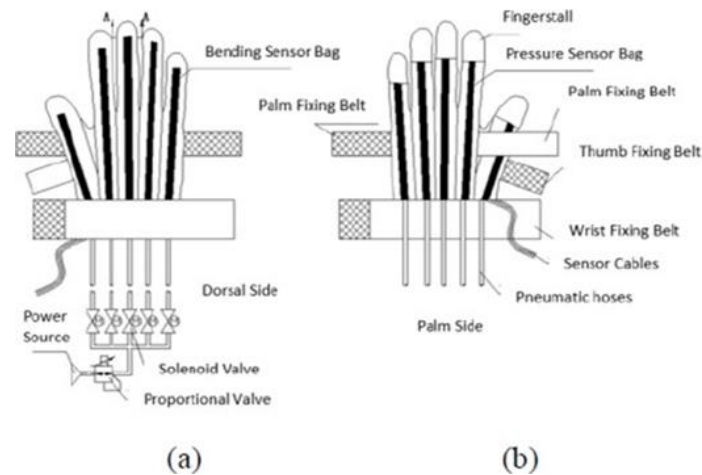

Figure 2.3 (a) Dorsal side view of glove (b) Palm side view of rehabilitation glove [15]

### C. Using 3D printed soft exoskeleton [16]

This design proposes a parameterized CAD design of a glove and 3D printing of soft compliant material. This design allows for portability and flexible modular design, allowing this equipment to be used outside of a hospital setting [16]. For the extension and compression of the fingers, this design uses a bidirectional cable-driven spooling system. The glove is made utilizing automated 3D printing of the flexible thermoplastic polyurethane (TPU), which can be customized for various hand sizes [16]. The glove's many components are printed individually, glued together, and made of a material with a shore hardness of 90A [16]. For the spooling system, micro-DC motors have been used to drive the spool.

The advantages of this design are,

1. 3D printable design.
2. Less complexity.
3. Compact and modular.
4. Can be used as a rehabilitation device as well as assistive device for daily activity.

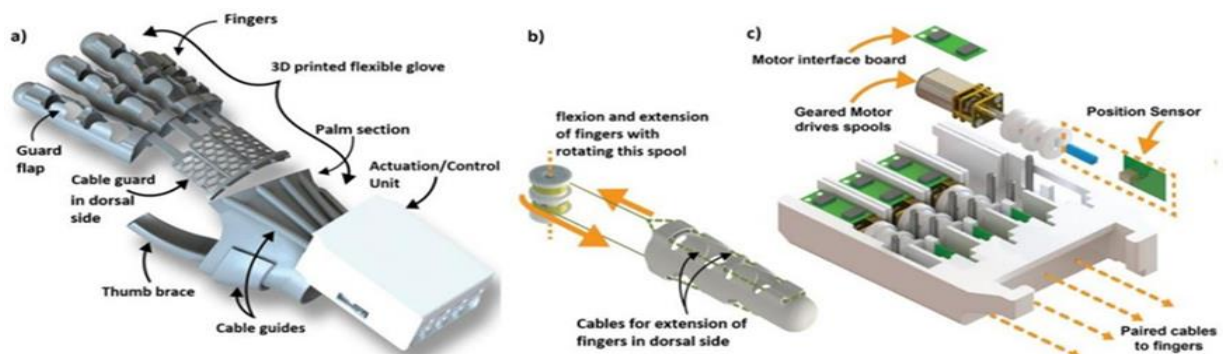

Figure 2.4. Flexo-glove diagram: (a) Overall assembly (b) Finger actuation (c) Actuation unit [16]

## 2.4 Analysis of multiple design approach

The project has been simulated in multiple software each providing different functional purposes. We analyzed the system response from MATLAB Simulink, created the electrical circuit of the system in Proteus and used Solidworks to create a CAD design. While designing the system in Simulink, we set the component parameters from the datasheets of those components and ran the simulation to have a real-life result of the system.

### A. Analyzing actuation using pneumatic cylinder

To analyze the actuation using a pneumatic cylinder, we took all the necessary blocks from Simulink. We needed a constant volume chamber, pipes, 4-way directional valve, double acting actuator. The gas inside the constant volume chamber is connected to the 4-way directional valve using a supply pipe and a return pipe making it a closed loop system. The input signal is provided by the spool position block. Depending on the input signal, the 4-way directional valve then controls a double acting actuator through pipe A and pipe B and the actuator moves back and forth depending on the signal provided by the spool input block. We can observe the position of the spool and pressure in the supply pipe through the scopes.

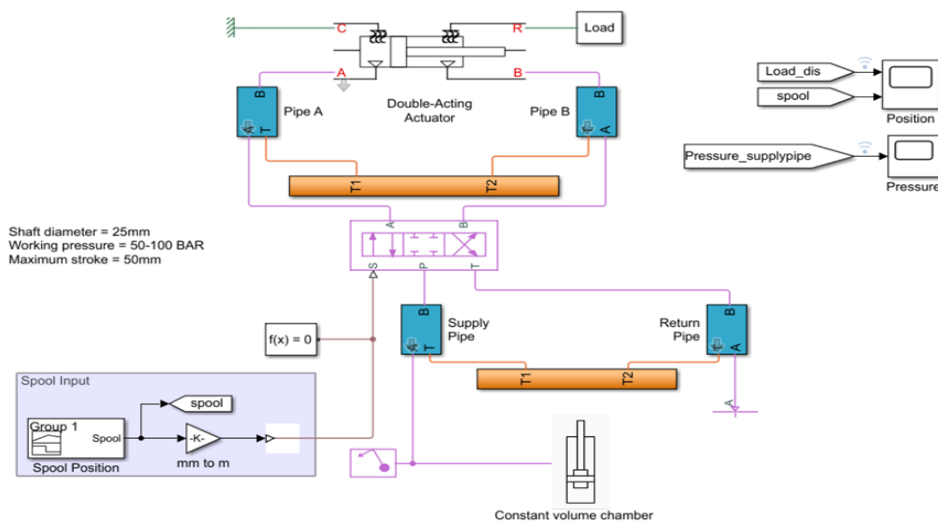

Figure 2.5 Pneumatic cylinder Simulink implementation

### B. Analyzing actuation using linear actuator

Another type of actuation technique can be implemented by using a linear actuator. There are different types of linear actuators such as DC motor linear actuator, stepper motor linear actuator and so on. The kind which we are using here in this simulation is a DC motor linear actuator. To simulate the system, we needed a constant block, speed control block, motor driver block, gear block, lead screw block and a load block. The speed is controlled by a PWM signal to the motor driver which is implemented within the control block as a child sheet. The simulation is demonstrated and inspected below as such:

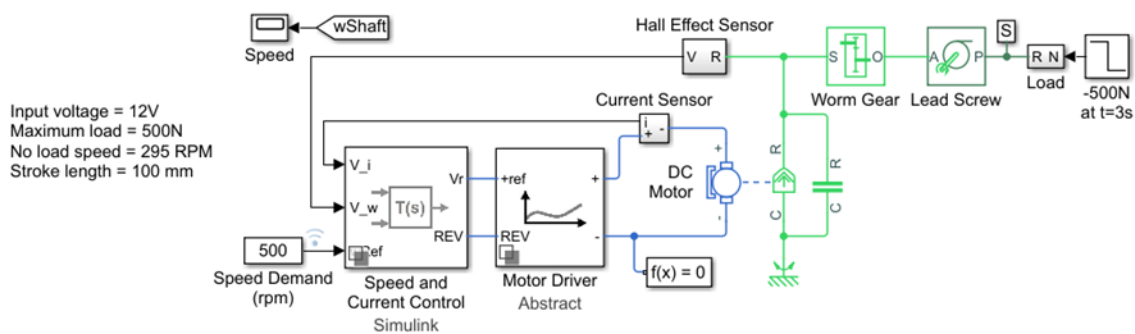

Figure 2.6 Linear actuator Simulink implementation

### C. Analyzing actuation using micro-DC motor

The final type of actuation for this project is by using micro-DC motors with a cable driven spooling system. The DC motor pulls the finger back and forth with the help of spools. To simulate the system, we needed a DC source block for PWM reference voltage, controlled PWM voltage block, H-bridge block, DC motor block. The PWM signal is provided to the H-bridge circuit, which is then connected to the DC motor, by which we can control both the speed and direction of rotation of the DC motor. The simulation is demonstrated and inspected below as such:

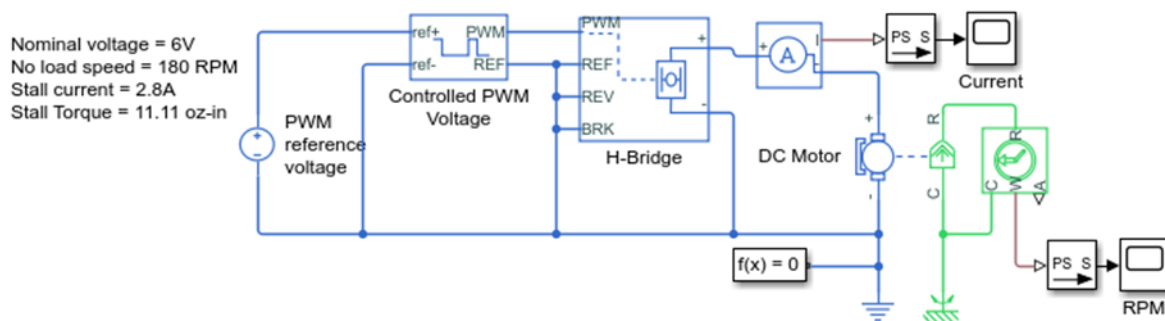

Figure 2.7 DC motor Simulink implementation

### 2.5 Conclusion

In conclusion, this hand rehabilitation design offers a comprehensive and effective way to help people with hand injuries and disabilities. It is compact, easy to use and has adjustable settings to suit individual needs. The design is highly sought-after due to its affordability and effectiveness. This hand rehabilitation design is a great addition to any rehabilitation clinic, helping to improve the quality of life for those with hand injuries or disabilities.

## Chapter 3: Use of Modern Engineering and IT Tool. [CO9]

### 3.1 Introduction

In the modern world of engineering, there are many tools and software that are used to design and create. The use of modern engineering and IT tools in the design process has made it possible to produce better products with less human interaction. Moreover, modern engineering and IT tools are used to make the design process more efficient. They can help designers to create 3D models in a shorter span of time, which is helpful when there is a tight deadline. Proteus, Solid works, Arduino IDE and Matlab are the most popular software among engineers and designers.

They have been used for years by professionals in the industry. Proteus is a CAD software that has been around since 1984, while Matlab is an interactive environment for numerical computation, visualization, and programming that was released in 1984 as well. Modern engineering and IT tools have enabled the rapid development of automated gloves of ours. This is also true for other devices and equipment that are used in the manufacturing industry. The use of these tools has dramatically improved the quality of life for people with disabilities, as well as those who are not disabled but have limited mobility. Our recent proposed project, automated gloves movement is a recent example that highlights how modern engineering and IT tools are being used in the medical field to create a better quality of healthcare for patients.

### 3.2 Select appropriate engineering and IT tools

It is important to select the appropriate engineering and IT tools for our proposed project to build the final prototype. We have to take into account the complexity of the project, time constraints, and feasibility of implementation. We should also consider what skills are available in our team and which tools are easier to implement a final prototype.

Our project is based on a hand rehabilitation system so the main and most important task is to control the extension and flexion of the fingers. The key difference of our multiple design approach is the actuation unit and other than that, rest of the works are quite similar. So, we had to choose software(s) which can provide us with all the necessary functionality of analyzing the different actuation characteristics and help us choose the best design for this project. There are many engineering and IT tools available to us. Some of the most popular ones include MATLAB, Arduino IE, and Solid Work are considered to build our proposed project. The following is a discussion of our chosen IT tools:

**i) MATLAB:** MATLAB is a software package for engineering and scientific computing. It includes a programming language and a graphical environment for designing algorithms and analyzing data which is developed by MathWorks. MATLAB provides an environment where engineers can simulate their work without having to do it in real life. It also contains many features that engineers need to use on a daily basis such as plotting graphs, analyzing data, and creating models. Additionally, the MATLAB program has a part called Simulink, that is a

graphical multi-domain simulation environment for modeling and simulating dynamic systems. MATLAB Simulink is a graphical programming tool that allows us to design complex systems by connecting simple components together with lines or arrows. It also provides the ability to simulate how these systems will behave in response to certain inputs or events in the future. Simulink Simscape is a library of Simulink blocks that provide an easy way to implement physical models of many types of systems. Moreover, it is an extension to MATLAB/Simulink that provides simulation capabilities on physical systems that are not accessible via traditional Simulink blocks.

To simulate the different actuation mechanisms of our proposed glove, we are choosing MATLAB Simulink to design and build the system with various blocks and observe the response of the system. Additionally, for the physical block diagram, Simulink Simscape has been used as a library and then the whole system has been implemented. Advantages of MATLAB Simulink include,

1. Modeling any system with custom blocks.
2. Analyzing the capability of both mechanical and electrical systems.
3. Real time solution of the system.

**ii) Solid works:** Solid Works is an engineering and IT tool that aids in 3D solid modeling. It is a very powerful software that can be used to create prototypes, designs, and a variety of other things. Engineers and IT professionals use Solid Works for 3D solid modeling. This is a computer-aided engineering (CAE) program that helps in designing, analysis, and visualization of the final product.

Solid Works was first developed by the company founded by John Walker in 1993. The company was named as “SolidWorks Corporation”. The company was acquired by Dassault Systems in the year 2012 and they are now known as “Dassault Systems SOLIDWORKS Corporation”. The software is used extensively in various industries such as automotive, aerospace, mechanical engineering, civil engineering, electrical engineering etc. It is also used for designing and analyzing products like machine components or parts of machines that are too complex to be designed with simple CAD tools or for any other purpose where 3D modeling is required. Moreover, SolidWorks uses parametric design which means the designer can see how one change will affect its neighboring components or the overall solution. SolidWorks also helps to visualize the design, how the design will actually look like in real life. It is also possible to print the CAD file and mount the electrical components right on top of that CAD design. The features of SolidWorks include,

1. Simple but sophisticated 3D CAD design.
2. Easily create animations and photorealistic renderings.
3. Cost estimation tool.

**iii) Arduino IDE:** The Arduino IDE is a cross-platform, open-source development environment that integrates with the Arduino hardware to make programming the board easy. The IDE can be downloaded and installed on Windows, Mac OS, Linux, and other operating systems.

The C++ language is a general-purpose programming language that has been standardized by ISO since 1998. It is one of the most popular languages in use today for developing software programs for computer systems. It connects to the Arduino hardware and uploads programs written in C++ to the board. We used Arduino IDE for our proposed project and the finger movements of the gloves were measured to detect proper response time. The finger movements of the gloves are controlled by a microcontroller or Arduino UNO which is mounted on the bottom of the glove. Flex sensors measure the pressure from the other hand glove and convert it into digital signals to be sent to the Arduino board. The proper response time for this project was about 1 second for every movement of the glove.

### 3.3 Use of modern engineering and IT tools

To design our automated hand gloves in software, MATLAB is our primary simulation tool, which essentially provides us the response data of a given design. So, three different designs were simulated, and the use of modern IT tools will now be covered.

#### i) MATLAB:

##### 1. Using 3D printed soft exoskeleton (DC motor)

To start the simulation of this design, first we launched the Simulink of MATLAB, then started to open the block diagram of our designs one by one. For this specific design, Controlled PWM Voltage, DC motor and H-bridge are our primary elements which are connected as a whole system.

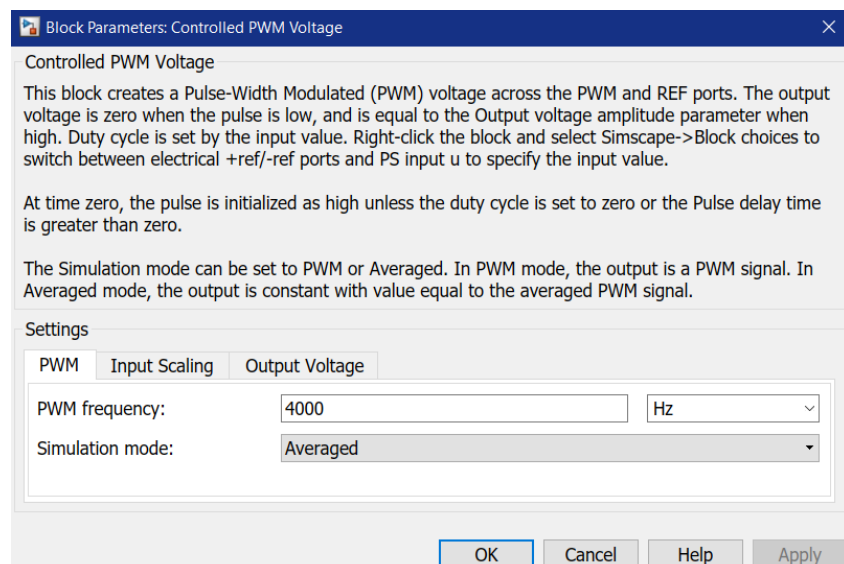
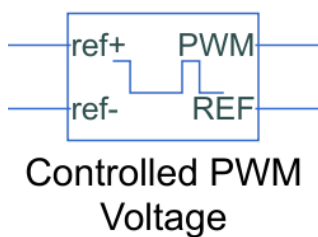

Figure 3.1 Block diagram and description of Controlled PWM Voltage

Here, we set the PWM frequency at 4000 Hz.

DC Motor

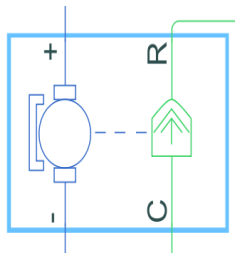
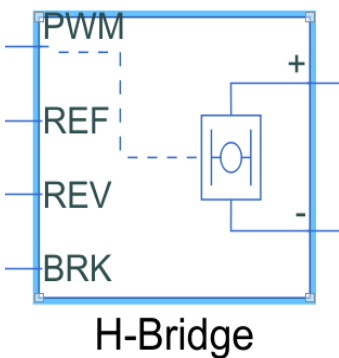

Figure 3.2 Block diagram and description of DC motor

Here, we set the parameters for the DC motors which we obtained from the datasheet of the motor.



H-Bridge

Figure 3.3 Block diagram and description of H-Bridge

Here, we set the H-bridge parameters. The power supply is selected as internal, simulation mode is selected as averaged, regenerative braking is selected as always enabled, and finally load current characteristics is set as smoothed



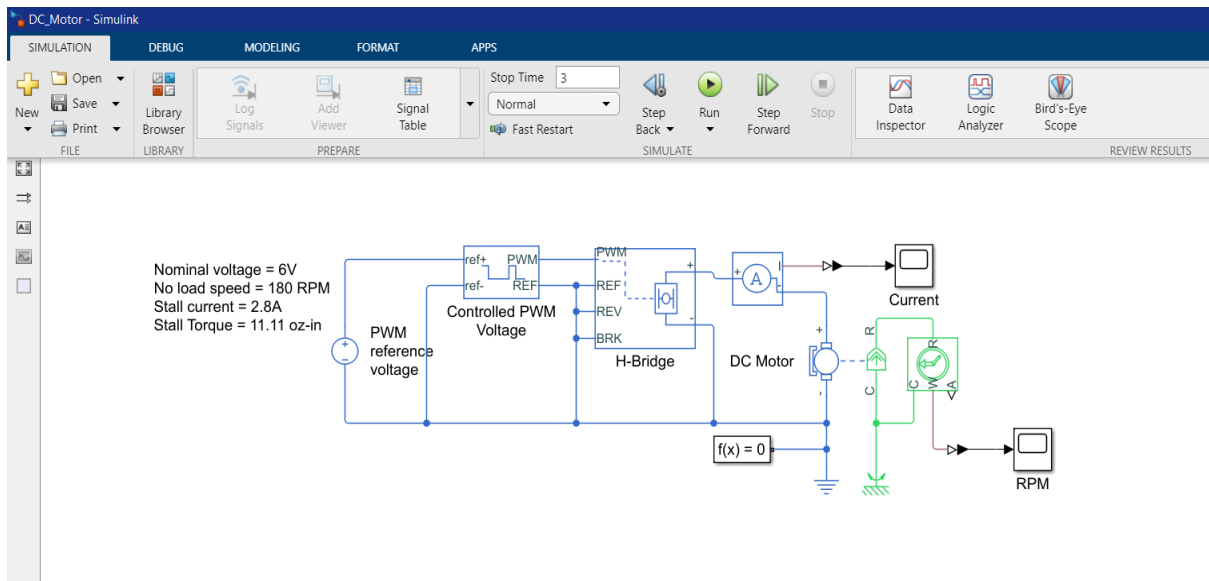

Figure 3.4 Whole system on the Simulink

## 2. Using three-layered sliding spring mechanism:

To design this system, which depends on the actuation of the slide spring mechanism. In this system, block diagrams we need are Motor driver, Speed and current control block and finally linear actuator system.

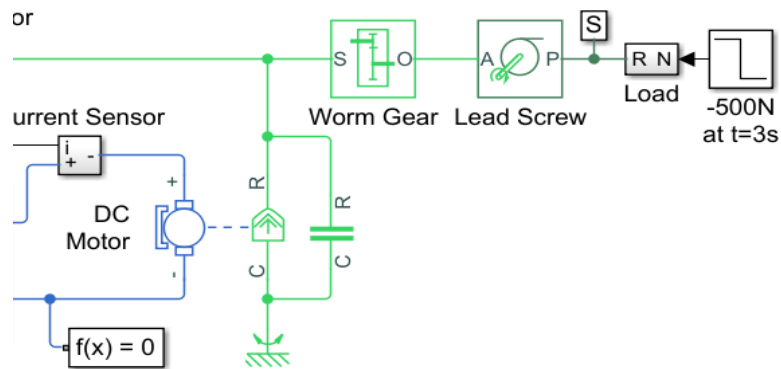

Figure 3.5 Block diagram of linear actuator

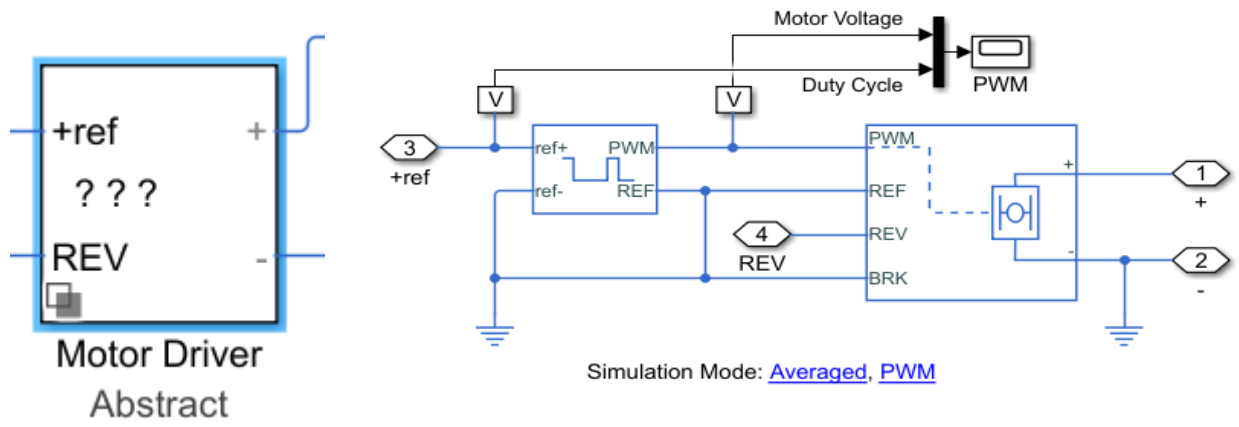

Figure 3.6 Block diagram of parent and child circuit of motor driver.

Motors used in linear actuators are usually high current consuming and for that we needed to construct a separate motor driver circuit for that which is shown above. Then we set the motor parameters according to the datasheet of the actuator.

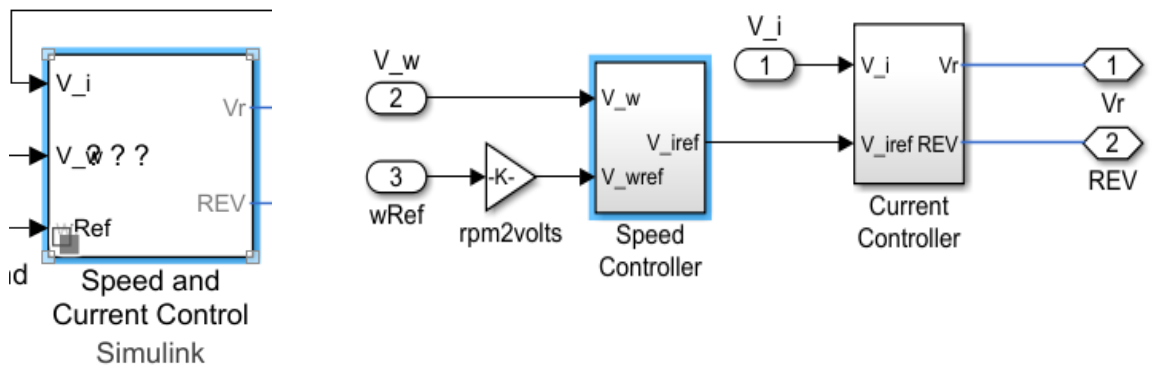

Figure3.7 Block diagram of Speed and Current control subsystem

Speed and current control unit is for the control of actuation. As we know, the shaft of the linear actuator either extends or constricts and to do that and also control the rate of extension or contraction of the shaft we built this speed and control unit.

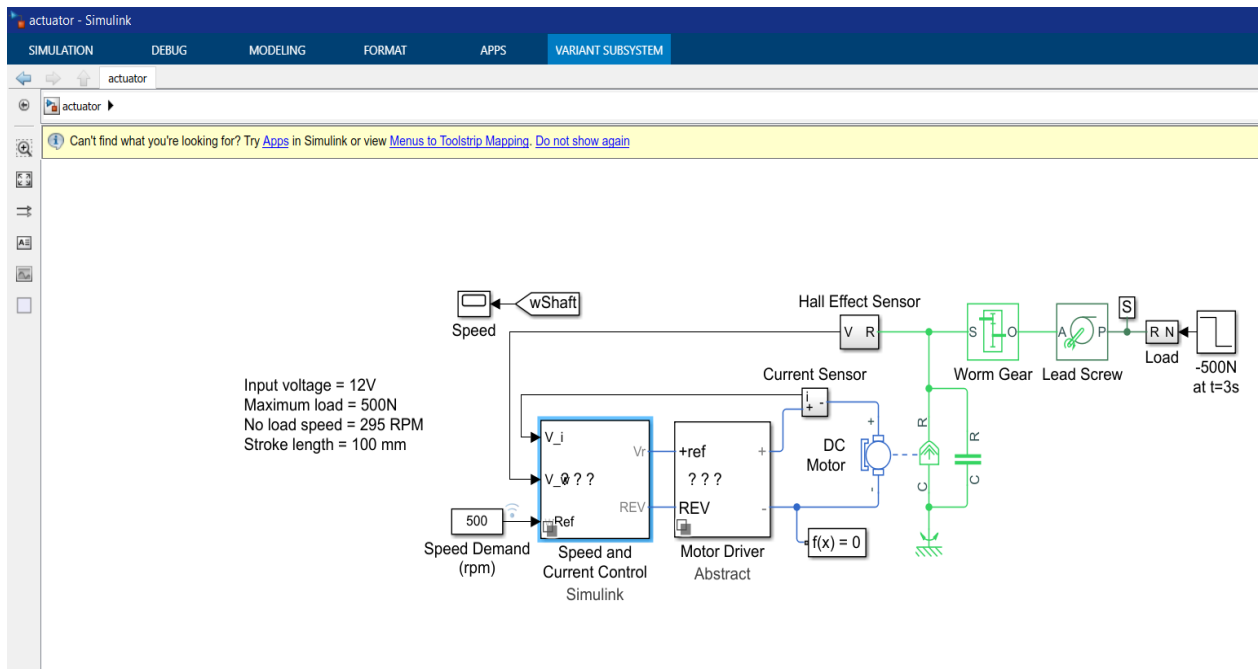

Figure 3.8 whole system on the Simulink

### 3. Using pneumatic cylinder and bending actuator:

To design this system, which depends on the actuation of the pneumatic cylinder mechanism. In this system, block diagrams we need are double acting actuator, 4-way directional valve.

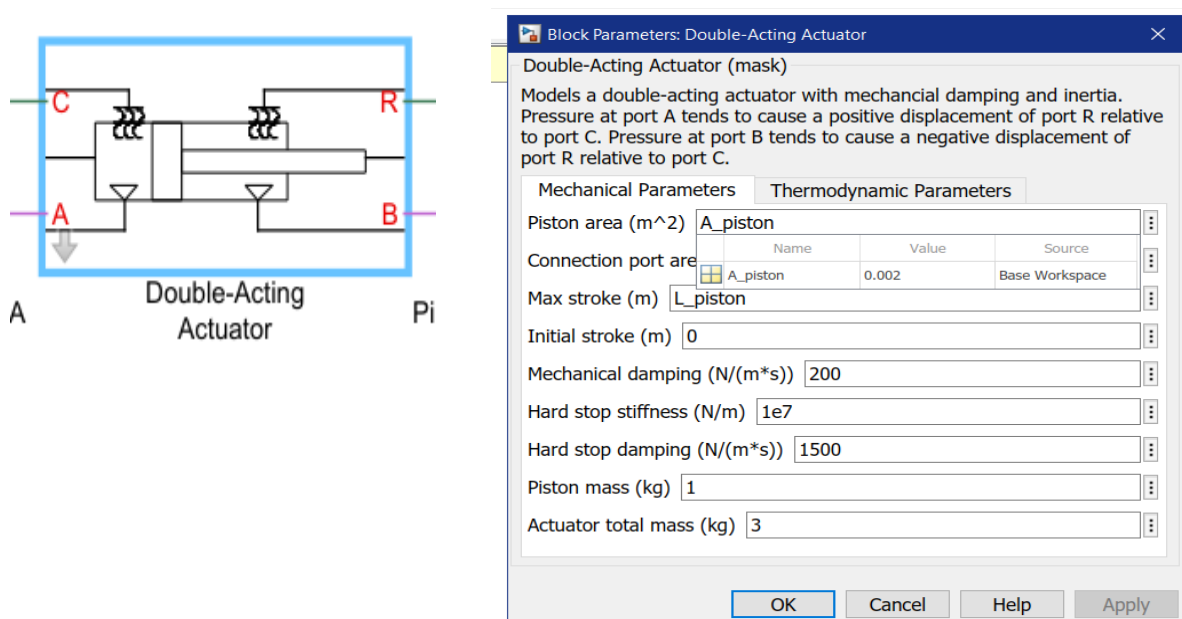

Figure 3.9 Block diagram and child circuit of double-acting Actuator

As pneumatic cylinders of small form factor are not available in our country, we took a reference of pneumatic cylinder from one of the existing rehabilitation devices and set the values according to that.

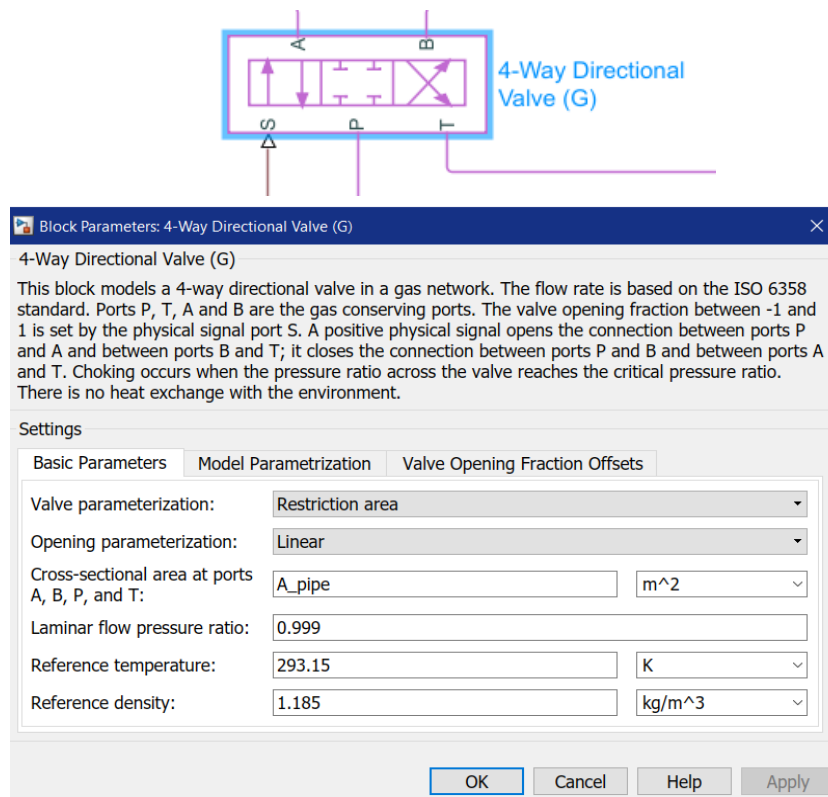

Figure 3.10 Block diagram and child circuit of 4-way Directional Valve

The 4-way directional valve controls the fluid pressure and directs it properly for the extension and contraction of the double acting actuator through pipes. We also set the value of this from the reference design.

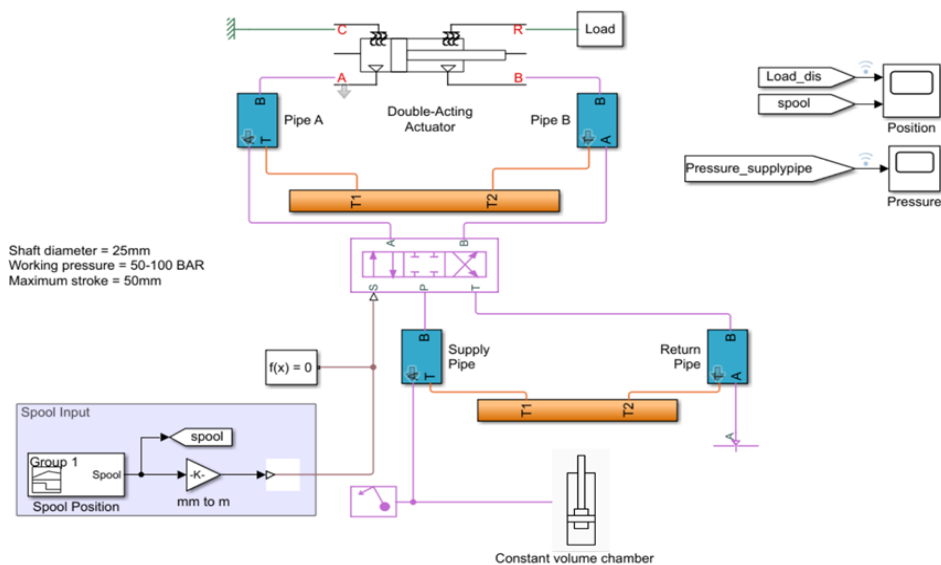

Figure 3.11 Whole system on the simulink

## ii) SolidWorks:

To give our gloves a visual representation, and also to print the CAD glove we needed to use Solidworks for 3D solid modeling.

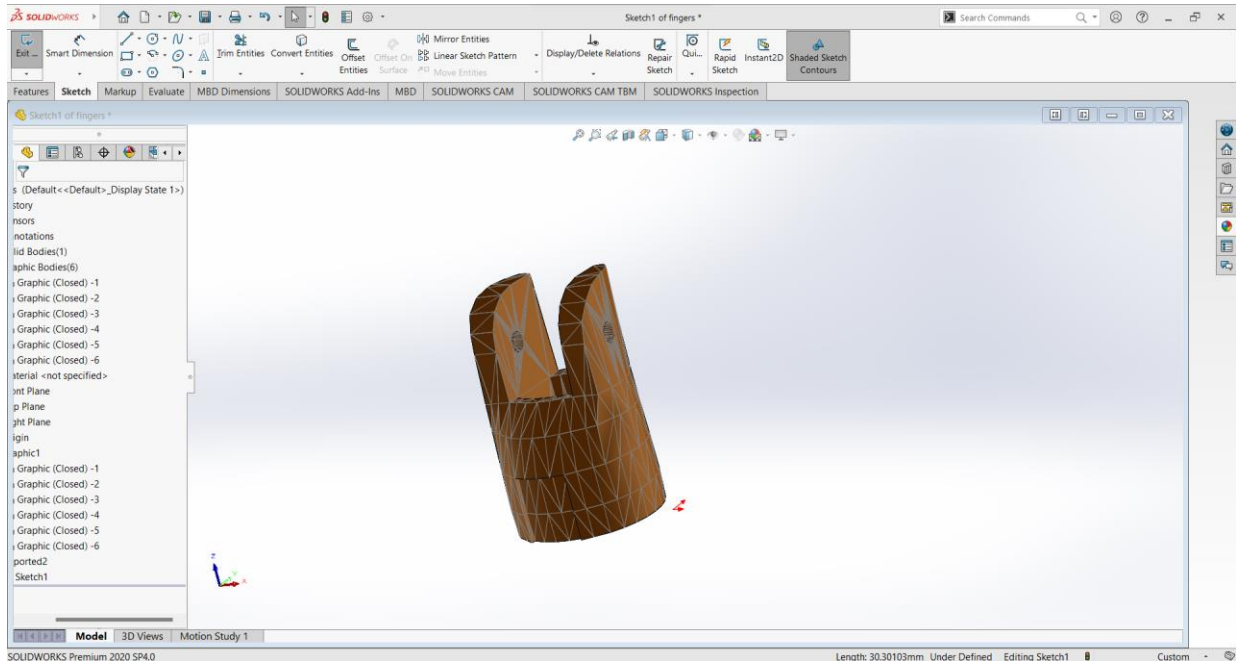

Figure 3.12 Designing 3D models of phalanges in Solid Works.

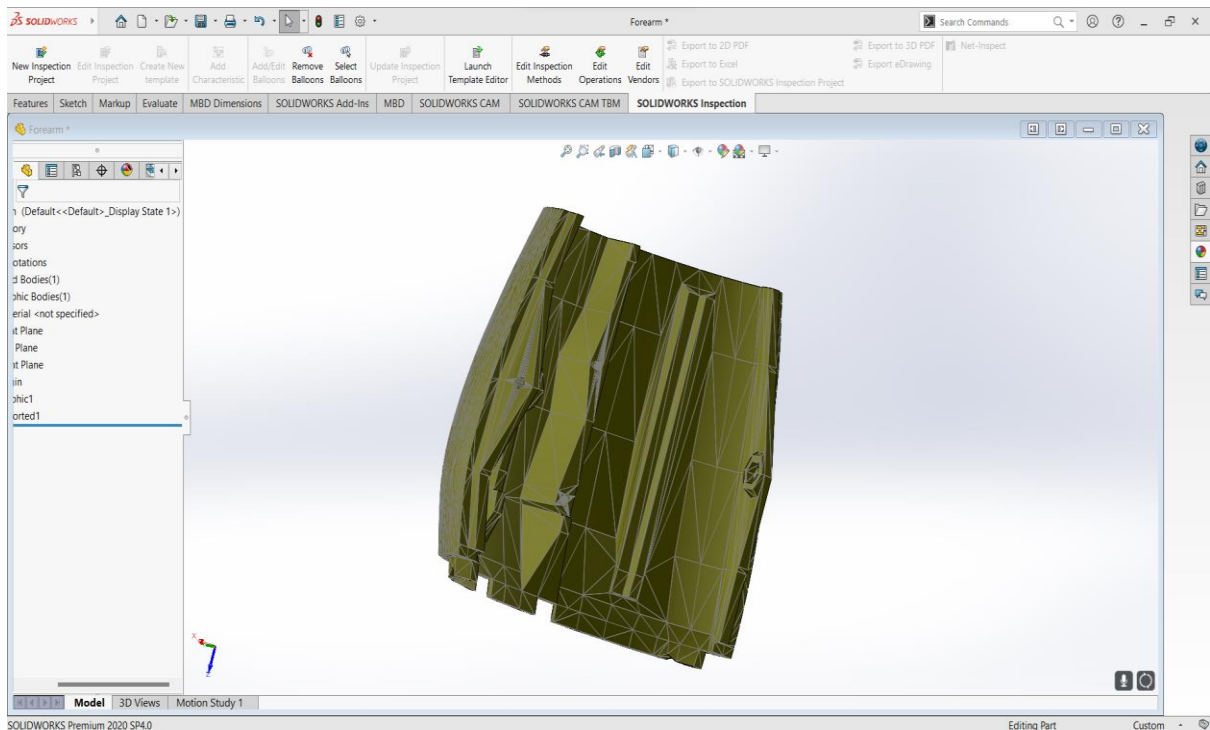

Figure 3.13 Designing 3D models of forearm in solid works.

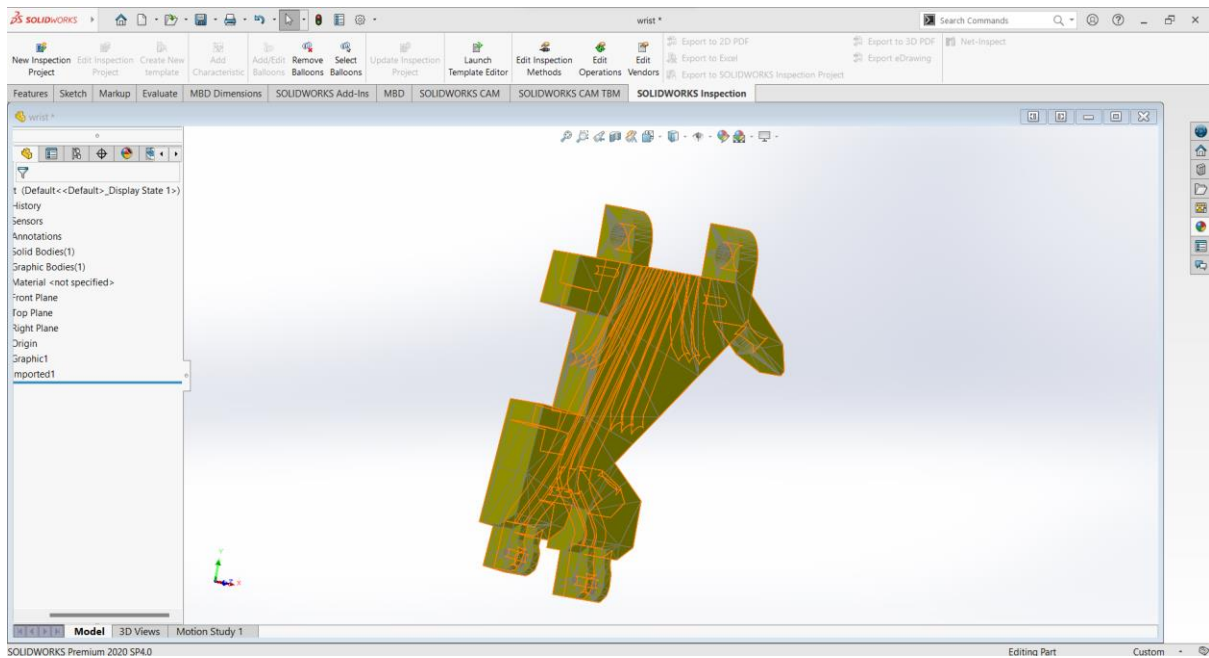

Figure 3.14 Designing 3D model of palm in solid works.

Here, we needed to measure the finger size, palm size considering average human hand size (both male and female) and design it on SOLIDWORKS. A glimpse of the 3D designing process is shown above.

### 3.4 Conclusion

To conclude, as the world is becoming more dependent on technology, engineers are needed to design and develop systems within a short amount of time and with proper optimization. We need to be creative and analytical in order to design and build our proposals. So, we also need to have a strong understanding of the use of modern engineering IT tools to create the best possible product.

We are always looking for new ways to improve their productivity as well as our designs. Though we mainly focused on MATLAB, it is one of the most popular engineering tools that is used by engineers throughout the world for modeling, analyzing, designing, simulating, visualizing and documenting solutions using Simulink. Later, we also used Solidworks to parameterize CAD design of the glove and 3D printing of soft compliant material. We modified the design deliberately using IT tools and softwares because of user comfort. Finally, the code has now been put into use through the Arduino IDE, enabling our system to start up and function automatically.

## **Chapter 4: Optimization of Multiple Design and Finding the Optimal Solution. [CO7]**

### **4.1 Introduction**

Design optimization is a process of finding the best design for a given problem. This process can be used in many different fields and is not limited to engineering. It can be used in healthcare, business, and many other areas.

The optimization of hand rehabilitation devices is a process that tries to find the best solution for designing an optimal device that will help people with hand disabilities to rehabilitate themselves by using their own hands.

This section discusses the role of multiple design optimization and how it can be applied to solve problems like this one.

### **4.2 Optimization of multiple design approach**

There are several methods to optimize the design and find the optimal solution for a hand rehabilitation device.

#### **4.2.1 Utilize simulation software**

Simulation software can be used to perform virtual testing of a device. This type of testing allows for the device to be tested in a virtual environment, allowing for more accurate results and faster results than if the device was physically tested. Simulation software can be used to test the device's performance in different scenarios and conditions, as well as to analyze the device's response to different types of input. This can allow for the detection of any potential issues with the device before it is released to the public.

For this, we have simulated our multiple designs in MATLAB Simulink and obtained response time for different designs which are as follows:

#### **A. Analyzing actuation using pneumatic cylinder**

A pneumatic cylinder, bending actuator was employed to construct the device in this design mechanism. This concept is multifunctional since it includes both a rehabilitation system and a robotic arm for grabbing items. In this device, unlike the other two designs with isolated valves, all five fingers may be controlled separately, and the input pressure is regulated by a proportional valve [15]. Each finger in the glove additionally has force sensors and bending actuators to monitor pressure at the fingertip and record the angular displacement of the corresponding MCP joint [15].

Here, we considered the working pressure of the cylinder to be 5–100 BAR, shaft diameter to be 25mm and the maximum stroke to be 50mm. The simulation results are demonstrated and inspected below as such:

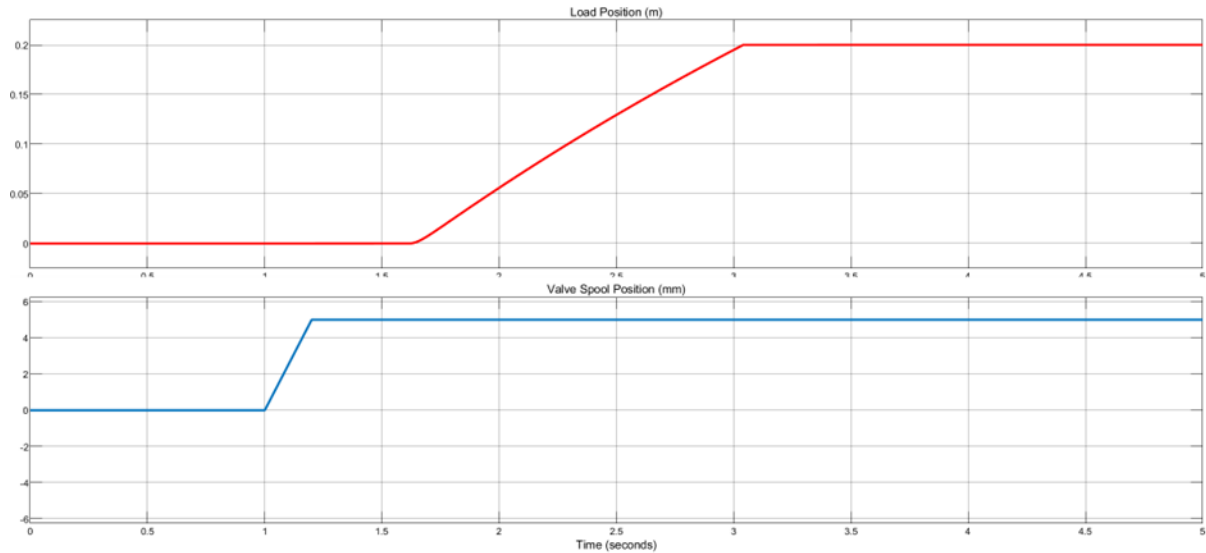

Figure 4.1 Load and spool position

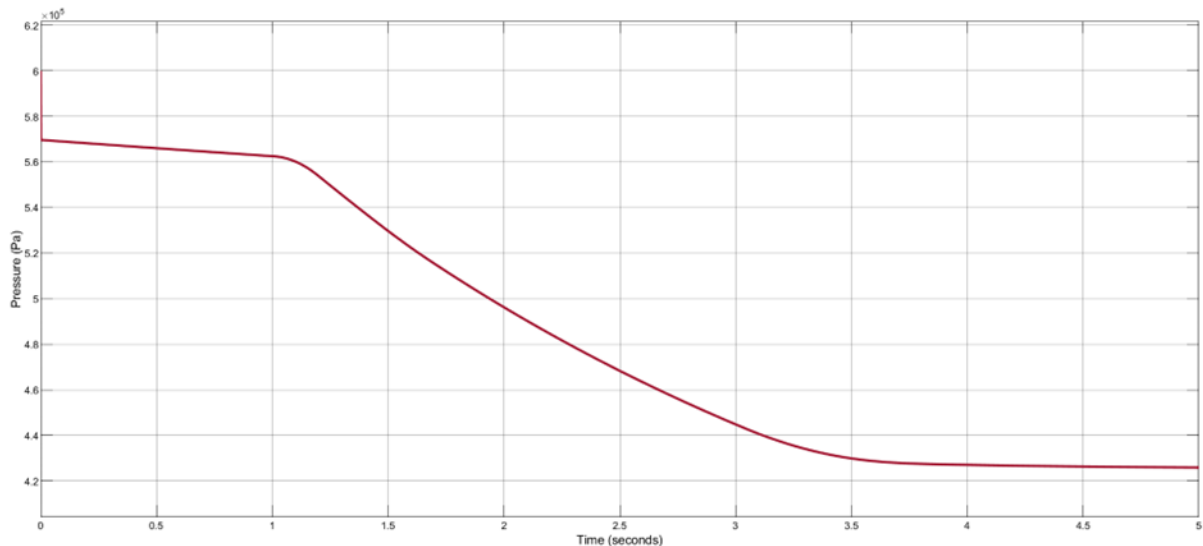

Figure 4.2 Supply pipe pressure

In the pictures above, we can observe the simulation result of the design which uses a pneumatic cylinder actuation mechanism. It is visible that when an input valve signal is given to the device, the load changes its position according to the input signal and the pressure inside the supply pipe also varies accordingly. This provides a validation of this design to use it in the actuation of the fingers. All the parameters of this simulation have been set according to the requirement for this design and validated by the datasheets of the individual components.

## B. Analyzing actuation using linear actuator

The finger motions are caused by a three-layered sliding spring mechanism in this design. A human finger typically includes three parts. Three sliding springs will cause these separate finger segments to move by transferring 1-DOF actuated linear motion into three rotating rotations of the finger joint [14]. To keep the system as simple as possible, only one actuator is



employed. This makes the device small and lightweight, and it also allows the four fingers to be activated at the same time. This design's key focus is that it is built on a compliant mechanism. In short, a compliant mechanism is made up of one or more elastic components that bend to change power in place of traditional mechanisms.

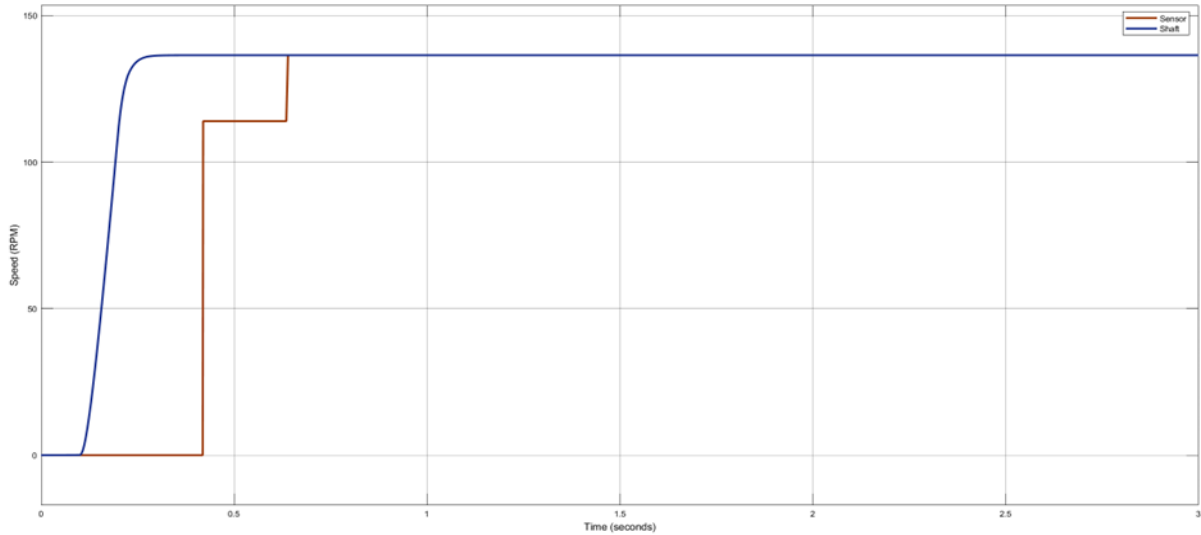

Figure 4.3 Motor speed of the linear actuator

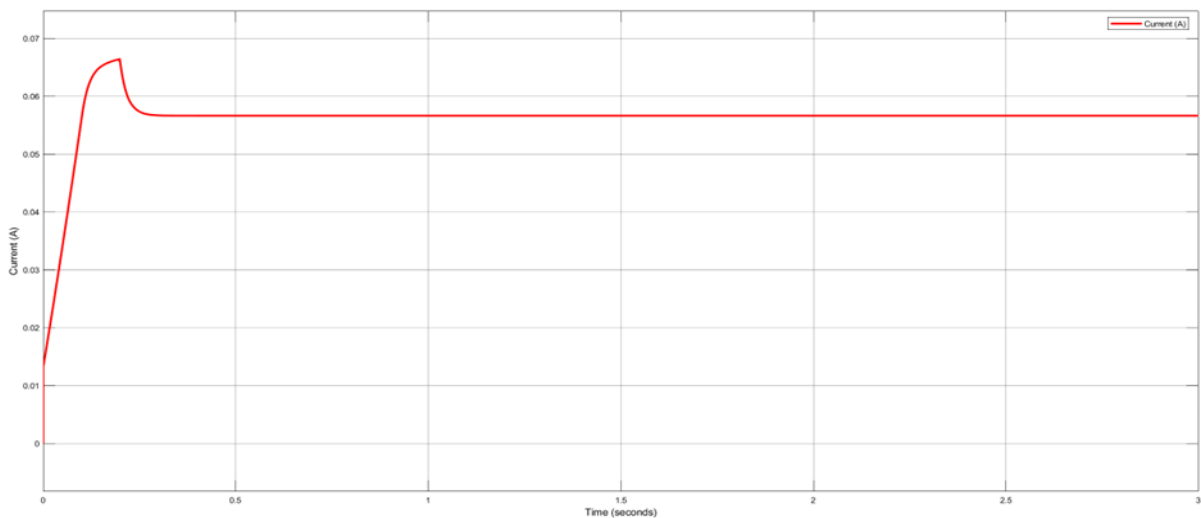

Figure 4.4 Current consumption of the linear actuator

Here, we can observe that the speed of the DC motor reaches 140 rpm exponentially and settles down. We can also observe the sensor data alongside the speed which follows the shaft speed of the motor. When the DC motor rotates, it expands the actuator shaft and when it rotates the other way around, the shaft of the actuator compresses accordingly. We can also observe the current consumption by the actuator. There is an initial spike of current when the motor starts spinning which then settles down after a certain time. All the parameters of this simulation have been set according to the requirement for this design and validated by the datasheets of the individual components.

The parameters we considered here for the actuator are as follows,

Input voltage = 12V

Maximum load = 500N

No load speed = 295 rpm

Stroke length = 100 mm

### C. Analyzing actuation using micro-DC motor

This concept presents a parametric CAD glove design and 3D printing of soft compliant material. Because of its mobility and adaptable modular construction, this technology may be employed outside of a hospital context [16]. This concept employs a bidirectional cable-driven spooling mechanism for finger extension and compression. The glove is created by automated 3D printing of flexible thermoplastic polyurethane (TPU), which can be modified to fit different hand sizes [16]. The glove's many parts are separately printed, bonded together, and constructed of a material with a shore hardness of 90A [16]. Micro-DC motors were employed to drive the spool in the spooling mechanism.

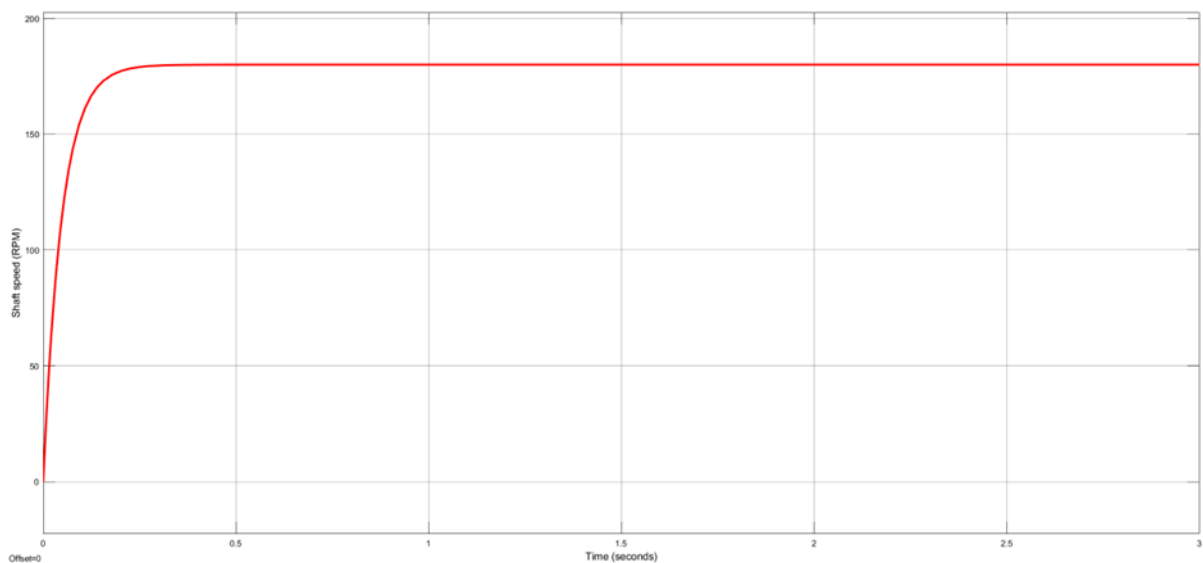

Figure 4.5 DC motor shaft speed

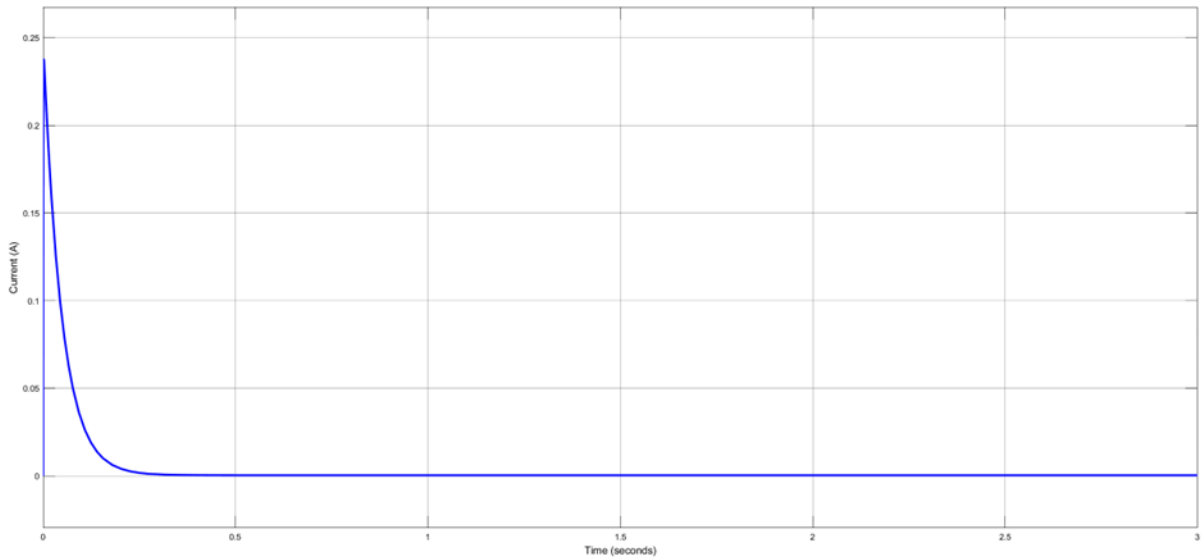

Figure 4.6 Current consumption by the DC motor

Here, we can observe that the speed of the DC motor is increasing exponentially and reaches 170 rpm. We can also observe the current consumption by the DC motor. Like the previous model, there is also a spike of current at the very beginning when the motor starts spinning and then the current approaches zero when the motor reaches its maximum rated rpm. All the parameters of this simulation have been set according to the requirement for this design and validated by the datasheets of the individual components.

The parameters we considered here for the micro-DC motor are as follows,

Nominal voltage = 6V

No speed load = 180 rpm

Stall current = 2.8A

Stall torque = 11.11 oz-in

#### 4.2.2 Utilize rapid prototyping techniques

Rapid prototyping techniques include 3D printing, laser cutting, computer-aided design (CAD) software, and other digital fabrication methods. These methods allow for quick iteration and testing of ideas, enabling the team to quickly identify and address potential issues. Additionally, rapid prototyping can help to reduce costs, as it eliminates the need for expensive tooling and allows for the creation of prototypes with minimal investments. Rapid prototyping can also provide important insights into the manufacturability of the device, allowing the team to identify any potential manufacturing issues before going into full production. For this, we have developed a 3D model of the device on SOLIDWORKS.

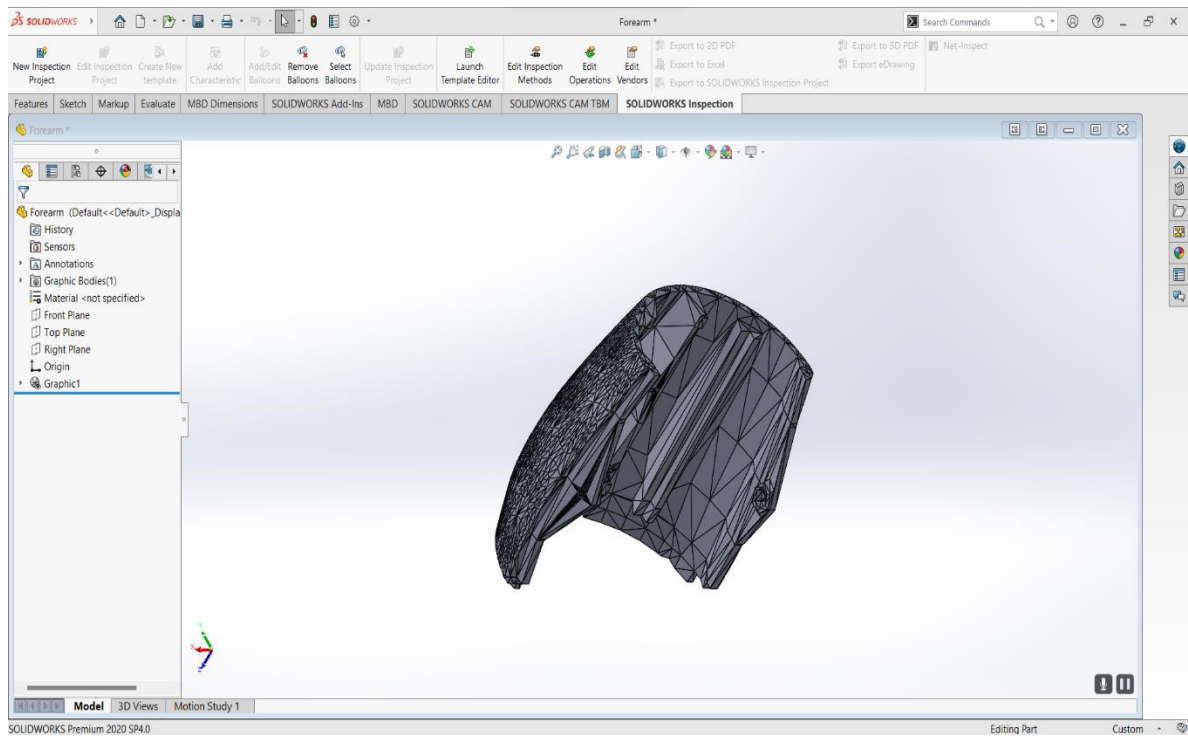

(a)

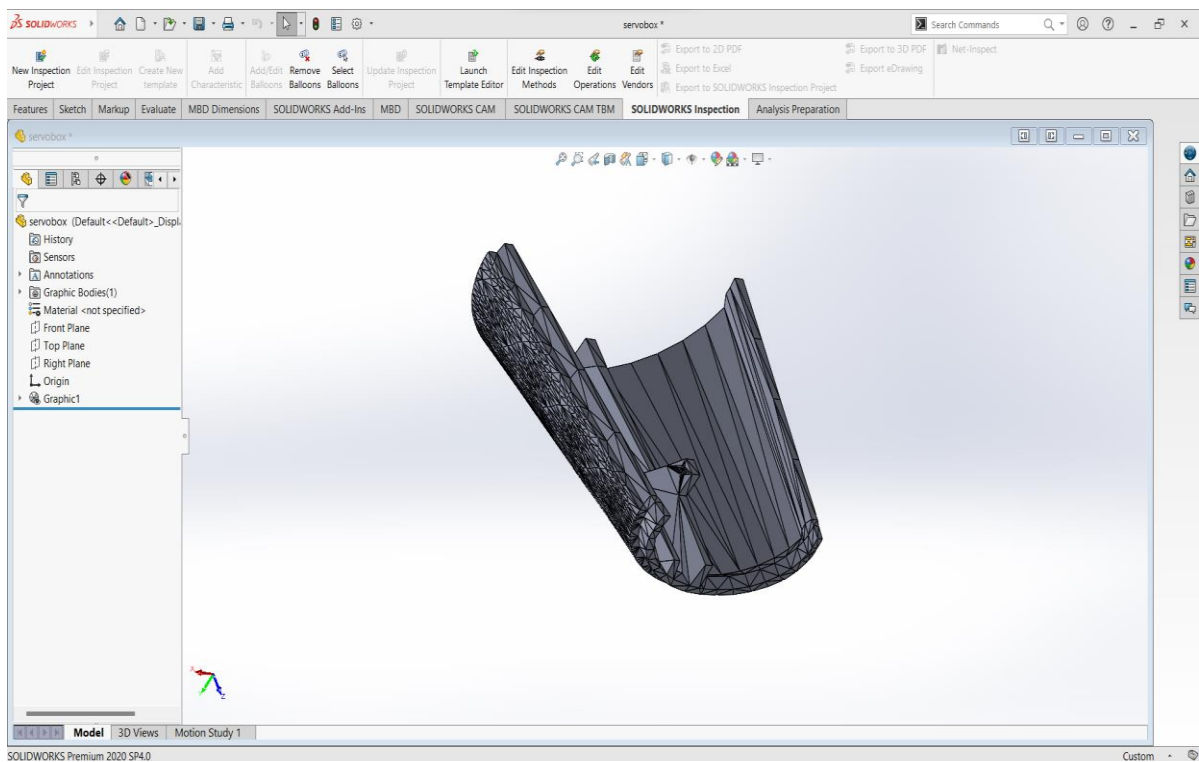

(b)

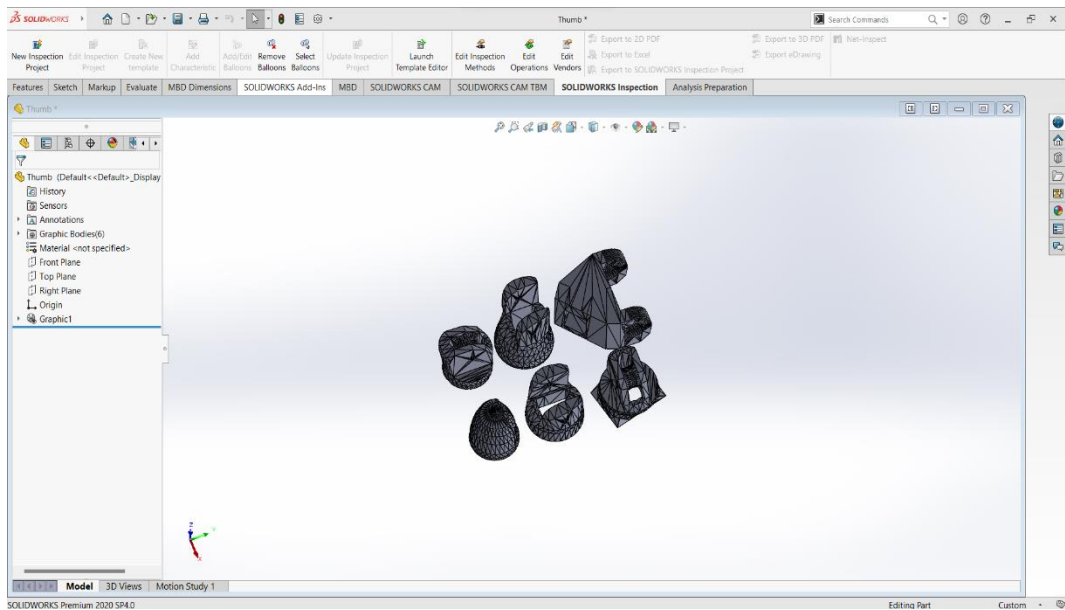

(c)

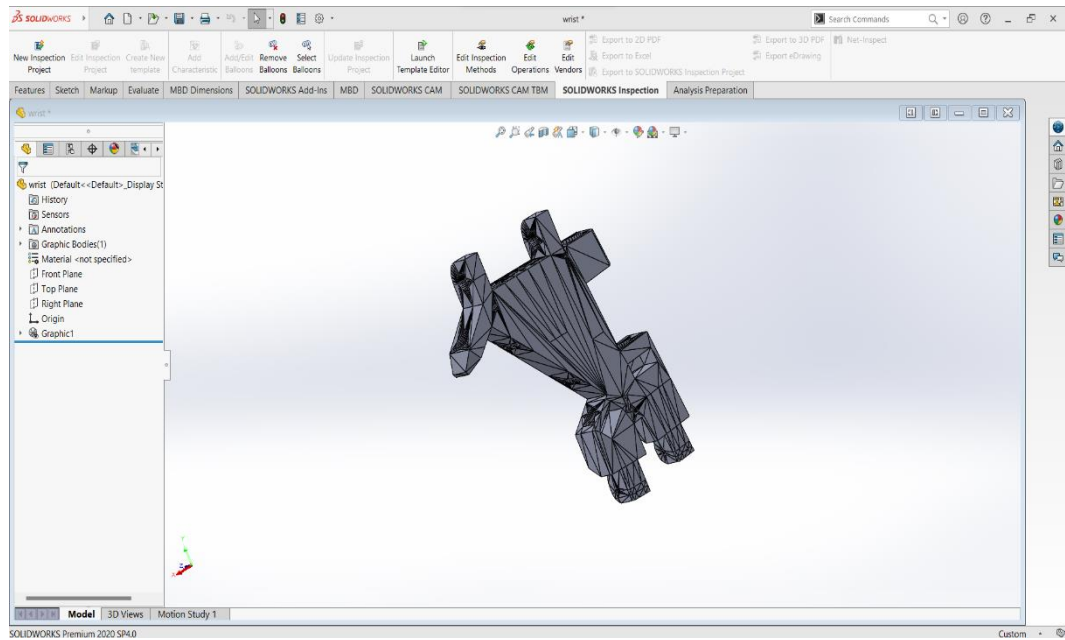

(d)

Figure 4.7 Using CAD software for 3D modelling, (a) forearm, (b) wrist, (c) phalanges and (d) palm

To do this, we had to take measurements of the average finger sizes to scale it in our 3D design. The average index and ring fingers (in mm) are about 78.4mm and 79.7mm accordingly for male, and 72.9mm and 70.5mm for female [18]

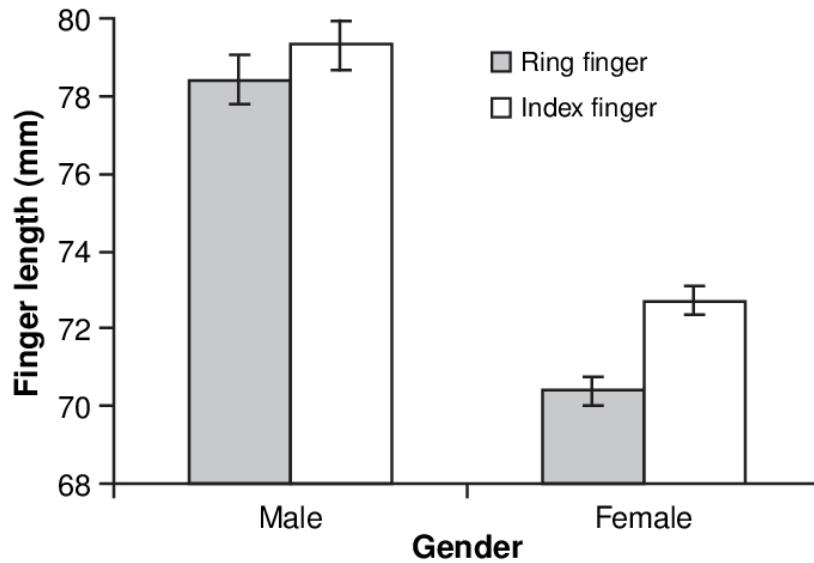

Figure 4.8 Mean finger length (in mm) for the index and ring fingers for males and females [18]

#### 4.2.3 Utilize Design of Experiments (DOE)

Design of Experiments (DOE) is a methodology used to identify factors that influence the outcome of a process or product. It is used to identify the most effective combination of inputs in order to optimize the output. DOE utilizes a factorial approach to systematically test a variety of design alternatives. This means that the design variables are tested by varying them in combination to determine their effects on the outcome. The steps of DOE include:

- i) Define the problem: Identify the design variables and the goal of the project.
- ii) Plan the experiment: Determine the number of levels for each variable and the type of design.
- iii) Execute the experiment: Run the experiment and record the results.
- iv) Analyze the data: Use statistical tools to analyze the data and identify the most important variables.
- v) Identify the optimal solution: Use the results of the analysis to identify the combination of variables that yield the best results.
- vi) Implement the solution: Make changes to the design based on the optimal solution.

DOE is an effective method for evaluating design alternatives and optimizing the design of a product or process. It can be used to identify the most effective combination of inputs and variables.

Firstly, we identified the key design variables and goal of the project. For example, the device has to be lightweight to ensure portability, it cannot be bulky as the device has to be compact to ensure wearability. The designs we considered for this project have fulfilled this criteria.

Secondly, the device needs to be very responsive to ensure uninterrupted and synchronous exercising/assistive experience of the user. To address that, our selected designs have a reasonable response time which is sufficient for day-to-day use.

Finally, we compared the simulation results and identified our optimal design in terms of cost, efficiency, usability, manufacturability, impact, sustainability, maintainability etc.

#### **4.2.4 Utilize user feedback**

Utilizing user feedback to identify areas of improvement and optimization includes,

- i) Collect user feedback through surveys and user testing: Ask users to provide feedback on their experience with the design, including what they like and don't like.
- ii) Analyze user feedback to identify areas of improvement: Examine the responses to determine common areas of improvement, such as navigation issues, usability problems, or lack of clarity.
- iii) Prioritize areas of improvement based on user feedback: Consider the impact the change will have on the user experience, as well as the costs associated with making the change.
- iv) Implement changes based on user feedback: Make changes to the design based on user feedback, taking into account the cost and time associated with making the changes.
- v) Test the design: After making changes, test the design to make sure it meets user needs.
- vi) Iterate: Gather more user feedback and continue to make changes based on user feedback.

At the initial stage, we could identify a few major user concerns that may appear. Firstly, the glove has to be made out of compliant material which would not cause any discomfort to the users as any sort of discomfort will make the user reluctant to use the device. Secondly, the cost of the device has to be affordable for most of the users of our country. Keeping these in mind, we selected our designs which are comfortable to wear and easy to manufacture in a cost effective way.

Further feedback can also be taken into consideration while the device is available in the market as the number of samples for the survey will be much higher.

#### **4.3 Identify optimal design approach**

As mentioned earlier, the main difference between our multiple design approaches is the actuation unit. The three design approaches proposed three actuation techniques which used a pneumatic cylinder, a sliding spring mechanism with a linear actuator, and a micro DC motor with a spooling system. The results that we obtained from the simulation are very close to each other, and for that reason, we cannot justify one design over another if we only consider the simulation results. To choose the best design, the weight of the overall system, the cost of implementing the design and availability of all the components, usability, manufacturability, sustainability, and maintainability also need to be taken into consideration.

The design that proposed the actuation using a pneumatic cylinder has some major disadvantages. The pneumatic cylinder needed for this design has to be small. Unfortunately, in our country it is not available, and we need to import this cylinder from a foreign country, which might not be a suitable option. Moreover, the pneumatic cylinder cannot be fully

controlled, which means it either expands all the way or compresses all the way, which can be a problem for our system. On top of that, the weight of a mini pneumatic cylinder is around 820g, which can make the system bulky when all the components are connected together. Finally, it has a slower response time compared to the other two designs, which is around 1.8 s. For the above-mentioned reasons, we are not considering the pneumatic cylinder as a suitable actuation technique for our project.

If we observe the response time of the other two designs, we can see that both the systems have almost the same response time, which is around 0.4s. The micro-DC motor that we are considering for our project has a weight of around 45g, so if we take 4 of these motors, the combined weight will be around 180g. On the other hand, the linear actuator we considered for our project is around 983g, which is way higher than the DC motors. Additionally, the price of the linear actuator is around 4850 taka whereas the price of one DC motor is 120 taka, so, in total it will be 480 taka, which is less than the linear actuator. Moreover, another advantage of the DC motor over the linear actuator is that all the motors can be controlled separately, whereas if we use a linear actuator, all four of the fingers will move together.

For the above-mentioned reasons and comparison between these three designs, we can say that the actuation using micro-DC motors with a cable-driven spooling system is suitable for our project. A comparison table is given below for better intuition:

Table 4.1: Comparison table of three multiple designs

<b>Design</b>	<b>Pneumatic cylinder</b>	<b>Linear actuator</b>	<b>Micro DC motor</b>
<b>Category</b>			
<b>Price</b>	40 USD or 3820 taka	4850 taka	480 taka
<b>Weight</b>	820g	983g	180g
<b>Component availability</b>	Not available in Bangladesh	Available	Available
<b>Response time</b>	$\pm 1.8s$	$\pm 0.4s$	$\pm 0.4s$
<b>Manufacturability</b>	Complex manufacturing scheme	Less complex manufacturing scheme	Easy to manufacture
<b>Usability</b>	Bulky and heavy	Less bulky but heavy	Compact and lightweight



<b>Maintainability</b>	Maintaining can be hectic	Maintaining can be hectic	Easier to maintain
<b>Sustainability</b>	Can sustain for a long time but debugging any fault involves complexity	Can sustain for a long time but debugging any fault involves complexity	Can sustain for a long time but debugging any fault does not involve any complexity

Since DC motors are widely available in our local markets, this system can be manufactured considering that motors can be purchased in bulk. Thus, the overall production cost may be reduced as well if we think about commercialization. Moreover, DC motors are durable and user-friendly, which makes for easier maintenance.

Our optimal design has a significant impact on the physiotherapy sector's automobilization because of its simplicity to build. As a result, our nation will become accustomed to using this kind of contemporary equipment in the medical sector. Additionally, as we emphasize cost effectiveness in this design, disabled people will have hope thanks to contemporary tools. The medical profession will change if this type of physiotherapy is made available to rural and semi-rural residents. A more affordable therapeutic system will encourage people to seek appropriate care without any hesitation.

#### **4.4 Performance evaluation of developed solution**

Performance evaluation for a hand rehabilitation device is the process of measuring the effectiveness of the device in aiding a patient's hand rehabilitation program. This could involve measuring the patient's range of motion and grip strength, as well as the patient's comfort and satisfaction with the device. It is important to measure the performance of the device in order to ensure that it is providing the best possible outcome for the patient's rehabilitation program.

When we implemented the project in hardware, we chose Servo motors instead of micro DC motors to reduce the complexity of the system. Additionally, there were not many rehabilitation devices in terms of commercial production which include servo motors for the actuation of the fingers.

To evaluate the performance of the new design with servo motors, we have done some testing of our device which is described briefly below.

##### **Test case 1: Measuring response time**

While we performed the simulation of our optimal design we got a response time of around 0.4 second but when we introduced RF transmitter and receiver in our hardware project, there is an extra added delay of signal transmitting and receiving is noticed here. While we tried to control our affected hand with our unaffected hand there was a delay of around 1.64 seconds which we calculated by stopwatch.



Figure 4.9 New response time after hardware implementation

Table 4.2: Delay time test

Test case	Time
Run time 1	1.62 sec
Run time 2	1.74 sec
Run time 3	1.91 sec
Run time 4	1.67 sec

Therefore, average delay time is 1.735 seconds

### Test case - 2: Creating sufficient pressure for finger flexion and extension

We used MG996 servo motors which have stall torque of 9.4kg/cm at 4.8V and 11kg/cm at 6.0V for our actuation unit. For a firm and stable grip of any object 20N force is required [15] To validate this test we initially wanted to hang a weight of around 2 kg as we know,

$$\begin{aligned}
 F &= mg \\
 \Rightarrow F &= 2 \times 9.81 \\
 \Rightarrow F &= 19.62\text{N} \\
 \Rightarrow F &\cong 20\text{N}
 \end{aligned}$$

This way we could verify if the 3D printed fingers can lift this much weight. Unfortunately, we did not perform this test because we used glues in some finger joints to hold them in place for which we did not take any risk as it might damage the device. However, the servo motors we used can lift this much weight at 4.8V easily so we assumed that our device can produce 20N

force for the fingers. If we could use metal hinges for the finger joints, we could have performed this test physically.

#### **4.5 Conclusion**

The optimal design solution of a hand rehabilitation project should include an individualized approach that takes into account the patient's specific needs, abilities, and goals. This should include a comprehensive assessment of the patient's physical and functional abilities, as well as a detailed plan of care that includes evidence-based interventions and activities. Furthermore, the design solution should include supportive technologies and resources that enable the patient to achieve their desired outcomes. Finally, the design solution should be evaluated on an ongoing basis to ensure optimal effectiveness and to allow for necessary modifications.

## **Chapter 5: Completion of Final Design and Validation. [CO8]**

### **5.1 Introduction**

The final design and validation of a hand rehabilitation device is a complex process that requires a thorough understanding of the anatomy of the hand, the dynamics of its movement, and the desired outcome of the rehabilitation program. In order to create a device that is safe and effective, a number of tests and evaluations must be completed to ensure that the device meets the highest possible standards. The tests may include assessments of the device's strength, flexibility, range of motion, usability, and effectiveness. Additionally, tests may also be conducted to evaluate the safety and accuracy of the device's operation. Once the device has been designed and tested, it must be validated in order to ensure that it meets the desired goals of the rehabilitation program. This means conducting clinical trials that examine the device's efficacy and safety in a clinical setting. The trials must include a variety of different patients, including those with different types of hand injuries or conditions. Results from these trials must then be compiled and analyzed to assess the device's overall performance. If the results indicate that the device is effective, safe, and meets all of the desired goals, then it can be approved for use in clinical practice.

### **5.2 Completion of final design**

The final design of the project should include an overall plan for the project, including the specific steps and tasks to be completed, the timeline for each task, and the resources needed to complete the project. It should also include any additional information needed to ensure the project is successful, such as any safety considerations, cost estimates, and other relevant details. The final design should also include any contingency plans in the event that the project runs into any unexpected problems or delays. Finally, the final design should provide a clear path forward for implementation and execution of the project. To complete building the project, we have divided the whole thing into eight steps so that the debugging process becomes easier and the workflow will be more sophisticated. Below, the breakdown steps are mentioned and described comprehensively.

#### **Step - 1: Printing the 3D design**

The first step to completing the hardware implementation was to print the parts of CAD designs we established. There are several places where one can 3D print their design commercial. We looked online, tried to find out the best place where the quality of the 3D printed parts will be up to the mark. Initially, we printed the finger joint parts to see if there were any mistakes in the design. Unfortunately, the finger joints were not fitting into the rest of the finger parts and thus we needed to make some changes in the design which would fit into the other parts of the finger without any problem. After making the necessary changes, we printed the parts of the whole device which took around two days to be printed and shipped.

## Step - 2: Assembling the parts

The next step after receiving the 3D printed parts was to assemble them altogether. As every single part was printed individually, there were a lot of small parts which needed to be assembled. The major problem in this part was to sort all the parts of the individual fingers. As the sizes of the fingers were very similar to each other, it was hard to distinguish which part belonged to which finger. After sorting out the individual parts of all five fingers, it was time to join them altogether. We used small metal strings to make a joint of the finger parts. Thenceforward, it was time to mount all the fingers in the palm part of the hand. It was farley an easy task to do as the palm had placings to only hold specific fingers in specific zones. Consequently, the palm was then mounted on top of the forearm part which also holds the servo motors for the actuation of the fingers. We needed several bolts to hold the palm and the forearm together which was hard to find. The bolts we found were either too big or too small for the hole which was created to place the bolts. After cutting those bolts with hex blade, we were finally able to mount it in place,



Figure 5.1 Assembling of 3D printed parts



Figure 5.2 Assembling of 3D printed parts

### **Step - 3: Mounting Servo motors and strings**

The next step was to mount all the servo motors for the actuation of the fingers. The servo motors were placed in the forearm part. There was spacing to mount five servo motors in that part which was designed precisely. There were small circular objects which were then mounted on top of the shafts of the servo motors. The springs which pull the fingers were tied around that circular object all the way to the fingertips. When the servo rotates, the circular object also rotates along with the shaft of the servo motor which then pulls the fingers through the strings which are tied with the fingers which cause flexion and extension of the finger joints. The main obstacle for this part was to tie the string with the circular object and pass the strings through the finger joints all the way to fingertips. The strings were getting loose which caused problems for the actuation of the fingers. To fix this, we put some hot glue to hold the strings tight. This resulted in proper maintenance of tension of the strings.

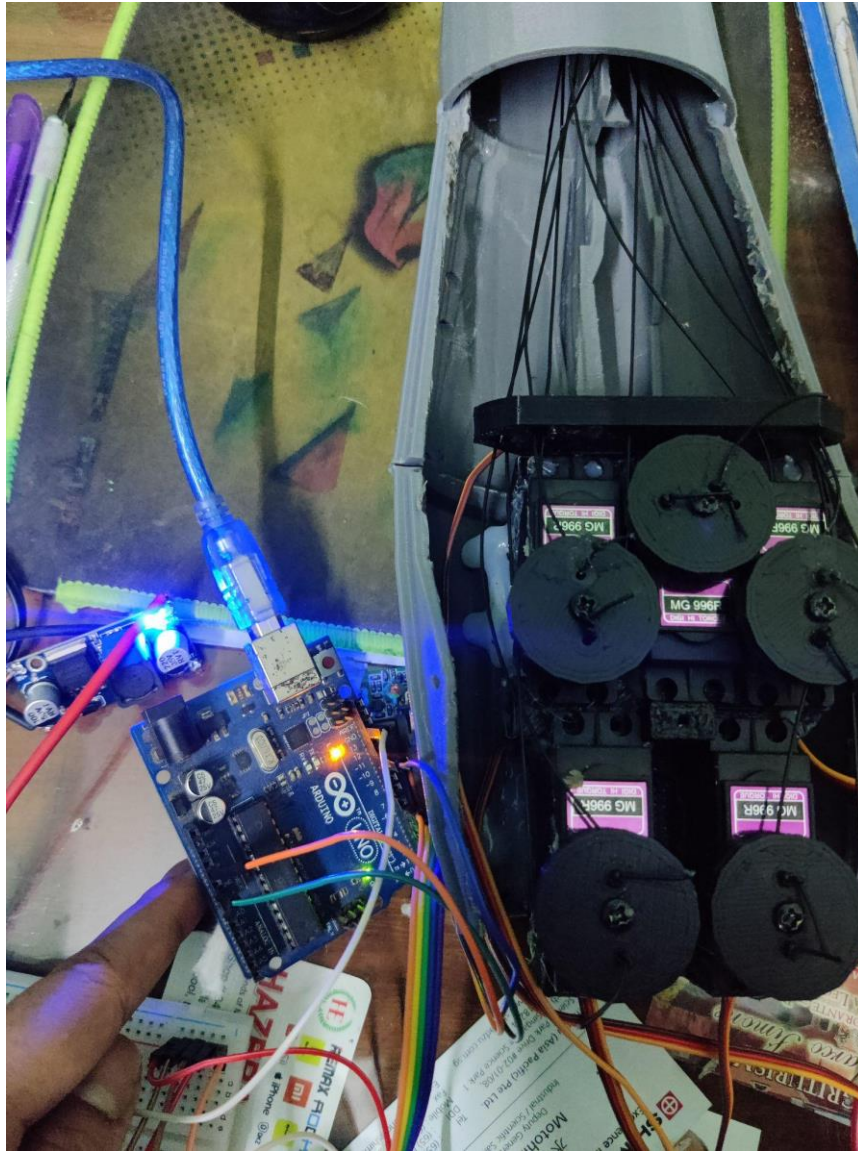

Figure 5.3 Mounting servo motors

#### **Step - 4: Making power supply for the Arduinos and Servo motors**

Next step, we built the power supply for both the Arduinos and Servo motors. The servo motors we have require 5V to operate. Initially, we planned to make the device with only DC, but it was not feasible as the batteries were running out of charge very quickly and using a higher capacity battery was also not an option as it will increase the weight of the device. Because of this reason, we decided to run the servo motors and Arduino which will be fitted on the affected hand by AC supply. Unfortunately, we could not find any 5V charging adapter with higher current supply capacity which is a must for running all five servo motors and Arduino at the same time. To address this problem, we used a 12V charging adapter instead which can supply sufficient current for all the components and used a buck converter to step down the voltage at 5V.

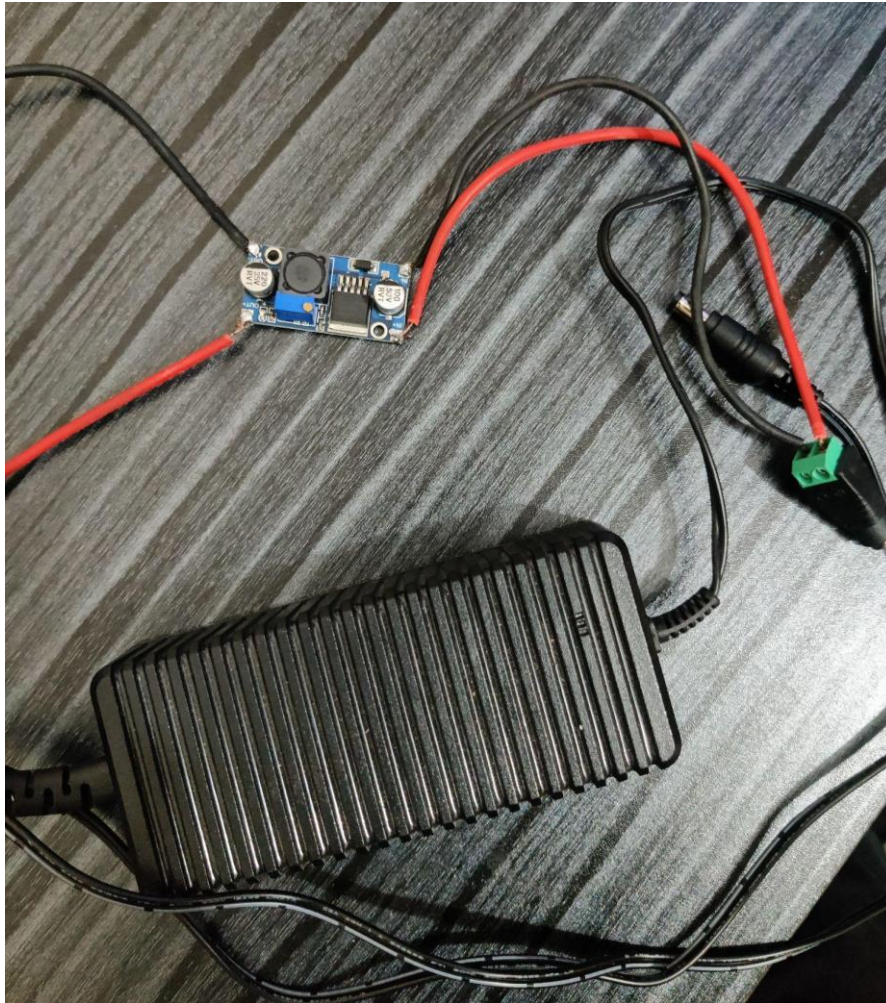

Figure 5.4 Mounting servo motors

### **Step - 5: Placing Flexi sensors on the other hand**

The next step for the hardware project completion was to place flexi sensors on the other hand. As we have already discussed, our device can automate the exercise session and it can also be controlled with the other hand for simultaneous exercising of both hands. To do that, we need five flexi sensors which will be placed on top of a hand glove. These flexi sensors will detect the flexion and extension of the fingers of the unaffected hand. Flexi bending sensors work by measuring changes in resistance due to flexing of the sensor. When the sensor is bent, the resistance across it changes, creating an electrical signal that can be measured. This allows for the accurate measurement of the amount of flexing in the sensor, which can be used to detect motion and pressure. The major problem with these sensors was that it sometimes does not give proper electrical signals and causes unusual movement on the other hand. To fix this, we ensured firm and steady placement of these sensors on the unaffected hand so that every movement can be measured accurately.





Figure 5.5 Placing flexi sensors on the unaffected hand glove

$R_{\text{sensor}} = 25\text{K}\Omega - 70\text{K}\Omega$

$R = 10\text{K}\Omega$

$V_{cc} = 5\text{V}$

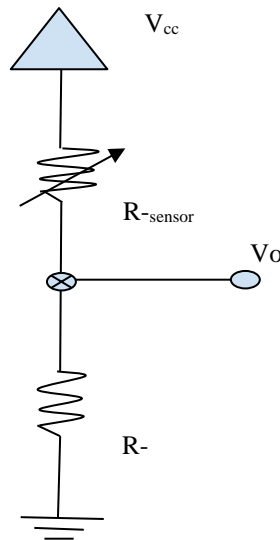

Figure 5.6 Flex Sensor circuit for the control glove

In the circuit, it is observable that the output signal can be calculated by the simple voltage divider rule. The output voltage ( $V_o$ ) varies along with the sensor resistance ( $R_{\text{sensor}}$ ) as the flex sensor contracts and expands. This output voltage is read as analog signals by the Arduino which uses the signals to send digital data via the RF transmitter. Additionally, the resistance ( $R$ ) in the circuit is used to provide better signal clarity. If not for the additional resistance the output voltage, theoretically, would be getting zero (0V) as it is connected to the ground.

### **Step - 6: Placing transmitter and receiver and calibrating them**

The next step includes placing the RF transmitter and receiver on both unaffected and affected hands respectively. The RF transmitter and receiver operate at 433.92MHz to communicate with each other. We need the transmitter to transmit the signal of the flex sensors which is mounted on the hand glove for the unaffected hand to the affected hand and the receiver to receive the signal and based on that signal the fingers of the affected hand move. We were required to calibrate the transmitter and receiver to ensure proper communication between them.

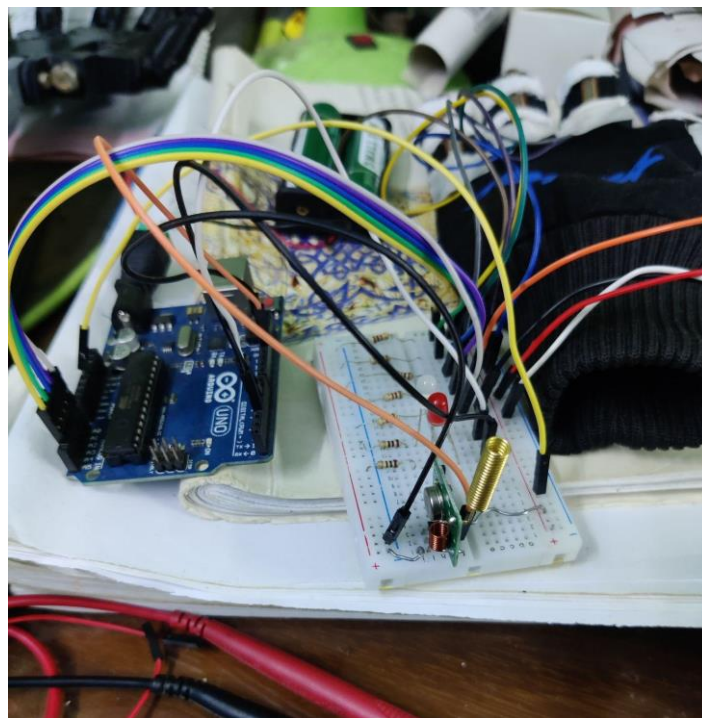

Figure 5.7 Placing transmitter on the unaffected hand glove

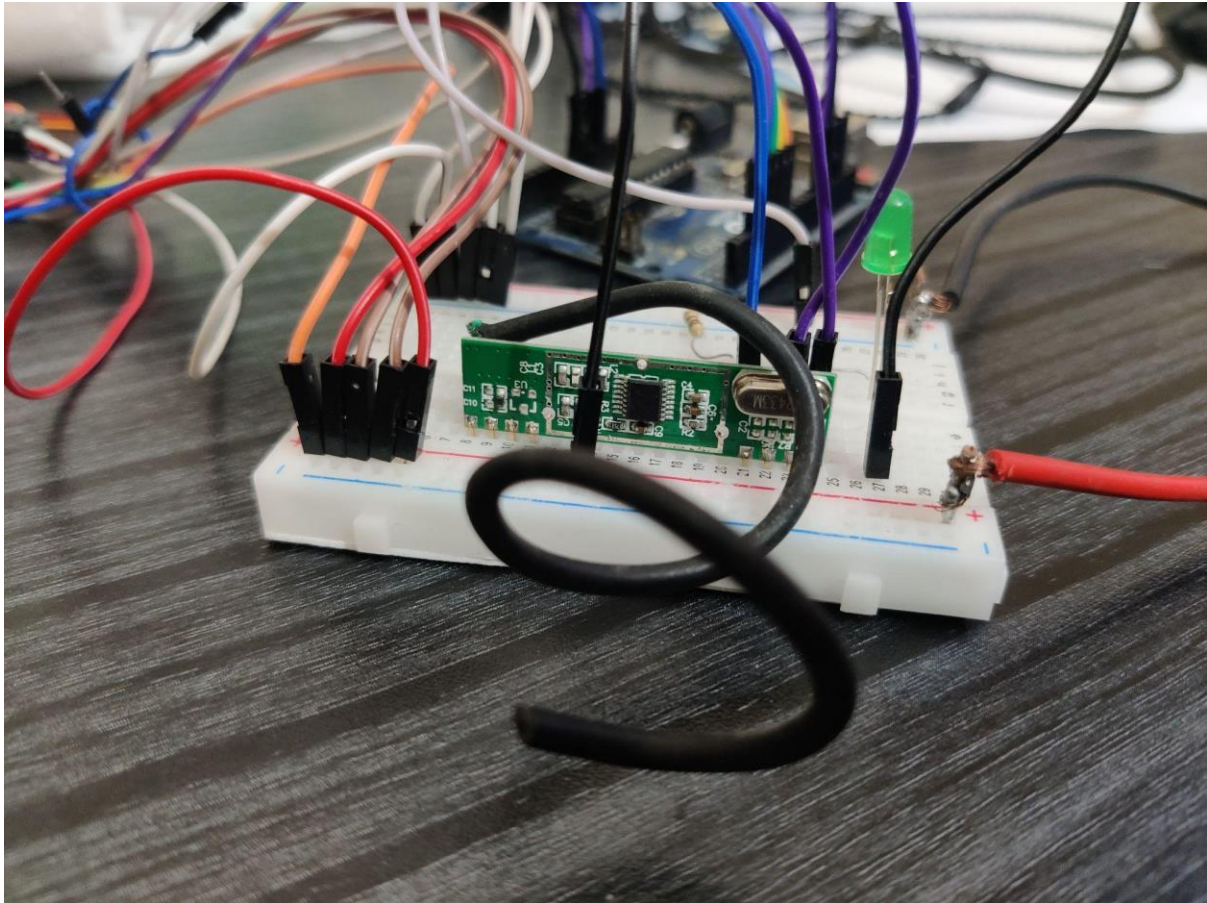

Figure 5.8 Placing receiver on the affected hand glove

### **Step - 7: Writing programs for both Arduinos**

Arduino programming is a process of writing code and uploading it to the Arduino board. This code enables the board to perform various tasks such as controlling motors, reading sensors, and communicating with other devices. Arduino programming can be done in C++ or the Arduino IDE. The Arduino IDE is a user-friendly software program that allows the user to write code and upload it to the board. It also has many features such as debugging, libraries, and example sketches. One of the major steps for completing this project was to write codes for both the Arduinos. We used two Arduinos for this project, one for the affected hand which receives the flexi sensor signal through RF receiver and operates the servos accordingly, and the other Arduino is for the unaffected hand which collects analog signal from the flex sensors and process it, and send it through the RF transmitter to the other Arduino. We wrote the program in the Arduino IDE and tested every single part of the code by uploading it to the board and making sure the task requirement is fulfilled,

```

1 #include <VirtualWire.h>
2
3 // pin denote
4 #define RED_LED 3
5 #define GREEN_LED 5
6 int thumbpin = A0;
7 int indexpin = A1;
8 int middlepin = A2;
9 int ringpin = A3;
10 int pinkypin = A4;
11 const int transmit_pin = 12;
12
13
14 // variable declaration
15 int thumbmax, indexmax, middlemax, ringmax, pinkymax;
16 int thumbmin, indexmin, middlemin, ringmin, pinkymin;
17 int thumbval, indexval, middleval, ringval, pinkyval;
18 double thumbtransmit, indextransmit, middletransmit, ringtransmit, pinkytransmit;
19
20
21 void setup() {
22   digitalWrite(RED_LED, LOW);
23   digitalWrite(GREEN_LED, LOW);
24   vw_set_tx_pin(transmit_pin);
25   vw_setup(2000);
26   Serial.begin(9600);
27   calibration();
28   // Serial.println("\nCalibration Done\n\n\n");
29   // Serial.println("Max: ");
30   // Serial.println((String)"Thumb: "+thumbmax+" Index:"+indexmax+" Middle:"+middlemax+" Ring:"+ringmax+" Pinky:"+pinkymax);
31   // Serial.println("Min: ");
32   // Serial.println((String)"Thumb: "+thumbmin+" Index:"+indexmin+" Middle:"+middlemin+" Ring:"+ringmin+" Pinky:"+pinkymin);

```

Figure 5.9 Arduino code for the transmitter side

```

1 #include <VirtualWire.h>
2 // #include <ServoTimer2.h>
3 #include <ServoTimer2.h> // the servo library
4 ServoTimer2 pinkyServ, thumbServ, indexServ, middleServ, ringServ;
5
6
7 double thumb, index, middle, ring, pinky;
8 double sensorArray[5] = {};
9
10
11 const int receive_pin = 11;
12 int thumb_init = 750;
13 int index_init = 2250;
14 int middle_init = 2250;
15 int ring_init = 2250;
16 int pinky_init = 750;
17
18
19
20 void setup() {
21
22   pinkyServ.attach(6);
23   ringServ.attach(5);
24   middleServ.attach(4);
25   indexServ.attach(3);
26   thumbServ.attach(2);
27
28   thumbServ.write(thumb_init);
29   indexServ.write(index_init);
30   middleServ.write(middle_init);
31   ringServ.write(ring_init);
32   pinkyServ.write(pinky_init);

```

Figure 5.10 Arduino code for the receiver side

### Step - 8: Analyzing and debugging the final product

The final step of completing this project was to analyze the final prototype and debug the system as a whole. In this step we will be able to identify if the overall system as a whole will be able to fulfill all the required requirements or not. After completing all the steps, when we built the whole device, we noticed that the fingers of the 3D printed hand were not bending as we expected. This happened because of the 3D printing material. The 3D printer left some debris along the edges of the printed object which was causing friction. To address this, we rubbed the edges of the finger joints with sandpaper to smooth it out. Additionally, we needed a two layer glove for the 3D printed hand, where the bottom layer of the glove was supposed to be worn by the 3D printed hand and the top layer of the glove was to put on the affected hand. Therefore, when the servos pull down the 3D printed finger parts, the actual fingers of

the affected hand will also move along with the 3D printed fingers. Unfortunately, we could not find such a glove and for that we have to custom make this glove.

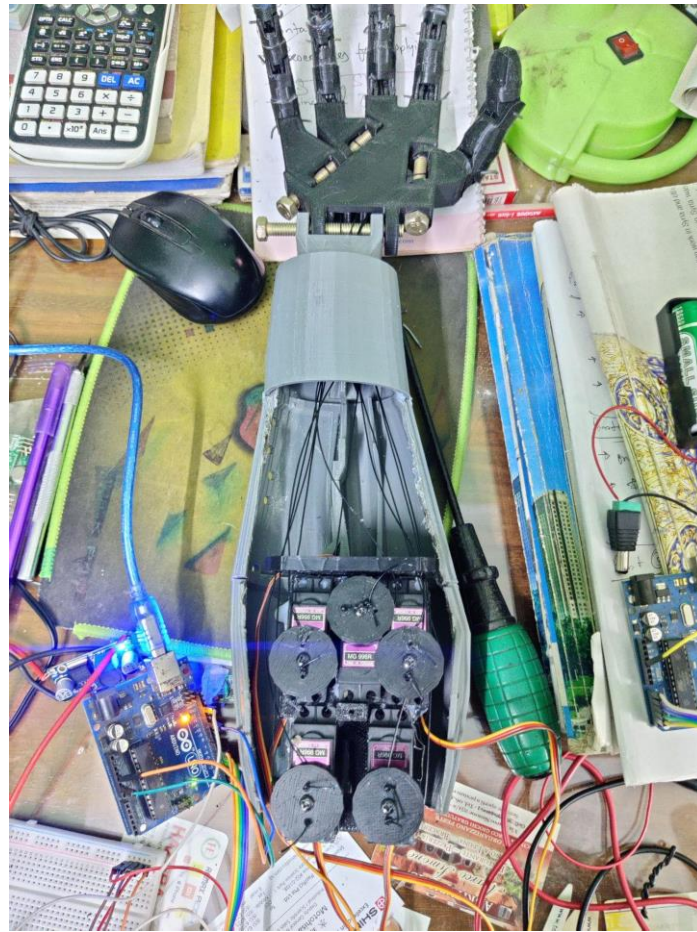

Figure 5.11 Final product after completing all steps

### **5.3 Evaluate the solution to meet desired need**

A hand rehabilitation device is a device that is used to help people who have suffered from hand injuries or impairments regain their hand function and strength. It typically includes exercises and other activities that help to improve grip strength, range of motion, and coordination. This device can be operated manually or electronically and can be used to help with activities such as typing, writing, and picking up objects. The device can also be used in physical therapy and occupational therapy to further improve the patient's hand strength and mobility.

To evaluate the solution at first we need to identify the desired needs for this project. To start with, we need to know the objective of this project. The main objective of this project is to build a device which will help stroke patients with their regular hand exercise. Initially, we intended to make it both rehabilitation and assistive device but due to some constraints such as increased weight, flaws in 3D printing material, weak spooling system, it was not possible to make it an assistive device as we intended. However, this device can be used as a rehabilitation

device. People who suffer from stroke are usually given some exercise, for example squeezing balls which can be easily done with this device. People who suffer from chronic stroke can lose significant muscle function and doing this simple exercise can be very hard for them. This device will definitely help them with the exercise which can eventually help them regain muscle function. When a patient squeezes a ball with their unaffected hand while wearing the glove which contains flex sensors, the device will receive that signal from those sensors and bends the fingers of the affected hand which will give the patient some strength to squeeze the other ball with their affected hand.

#### **5.4 Conclusion**

The final design of the hand rehabilitation device is now complete. After a long process of research, and planning, the device is now ready for prototyping. The device is designed to help those suffering from hand disabilities to regain strength and mobility in their hands. Thanks to the hard work of the whole team, this device will be able to help countless people improve their quality of life. With this device, we have taken a step towards a more inclusive and accessible world.

## **Chapter 6: Impact Analysis and Project Sustainability. [CO3, CO4]**

### **6.1 Introduction**

Engineering is the bridge between real world barriers and their solutions. The answers derived by engineers are solely for the advancement of mankind in general which makes it obvious that the general masses are the ones at stake whenever it comes to complex engineering problems. It is of utmost importance that the solutions of engineering problems must consider the societal, health, safety, legal, environmental, and cultural consequences as well as the sustainability of the developed project. Since complex engineering problems originate from real world issues, engineers must address the repercussions that they might have with their proposed solutions. On the other hand, sustainability is a vital key in any successful venture which makes a statement on the given resolution's continual and acts as a proof of feasibility.

### **6.2 Assessment of impact of the solution**

The tentative impact of the post-stroke rehabilitation system regarding societal, health, safety, cultural, and legal concerns are discussed below.

#### **6.2.1 Societal**

Since the primary target audience of this project are the poverty-stricken population of Bangladesh, this project will have an important impact on society. While privileged individuals can buy expensive devices for medical rehabilitation, low-income families will not be able to partake. Through our project, they can have access to the inexpensive medical aid they require. We have mentioned that reducing the cost of the device is our prime focus, which will improve the medical standard of a society that mainly consists of underprivileged people. This device, when developed further, will single handedly automate the rehabilitation procedures in our society that will go a long way in digitizing our nation.

Moreover, the rural people of our country will be familiarized with modern healthcare systems through this device, which will help build a more educated and concerned generation of people. When exposed to automation our society will crave more for such innovations which will trigger a domino effect that will beget many advances in technology. Additionally, all sorts of systems will need to be further modified according to the needs of its users. In technical terms, after our system becomes available on the market for the people, we will be able to gather much more essential data which will aid in upgrading our device. For example, users might find a need for a faster response of the servo motors which can enable vigorous exercising routines. Consequently, we will then need to improve our device accordingly.

### **6.2.2 Health**

The sole purpose of this project is to automate medical therapy procedures and rehabilitation. Indeed, this device is aimed at improving the health of its users. Since our device will help to regain functionality of the paralyzed hand, it will certainly improve the health and living standards of paralysis patients. Furthermore, it will reduce dependency on human interactions along with human errors.

There are many rehabilitation methods, including sensory retraining exercises, mirror therapy, and even electroacupuncture. In electroacupuncture, some needles are used to regain the nerve's activity. After the needles are inserted into the acupuncture points, the electrodes are attached to the pairs of needles, and then a small electric current, usually with a pulse frequency of 1–100 Hz and a pulse amplitude of 2–3 mA, is passed through the needles into the subject for 15–60 min. After a session, someone may feel fatigued for up to 3 days, mildly nauseated, dizzy, with redness or bruising at the puncture site, along with many other side effects. Such side effects can be avoided by using our system. In addition, our device will be resourceful and time efficient. For instance, a patient will not need to spend their time traveling to therapy centers and waiting in queues. In physiotherapy centers there are limited physicians attending to a significantly more number of patients which results in longer waiting periods for a comparatively less therapy session time. On top of that, such physiotherapy sessions usually charge by the hour or per session which is a continuous expenditure for the patients. Our system will be a single investment for the clients at the very beginning that will ensure convenience, time and cost efficiency.

### **6.2.3 Safety**

Safety concerns in an electronic device is one of the fundamental criterion to focus on during development. More digital the device, the more risks it entails. Numerous tests in any engineering problem about safety and security must be simulated before exposure to the market. In fact, it is the underlying principle of engineering that trial and error is the process through which a project attains success. To add, failures in the system provide valuable data about where it needs to be improved. Any device must be presented to the general people only after various safety tests and simulations as any developer would want to avoid accidents along with potential lawsuits. Thus, assessment of safety regulations in any engineering project is of paramount importance.

As our project involves electrical components such as batteries, motors, and sensors, there is always a chance of a failure. A short circuit in the system can be fatal and cause the battery to explode, which will have a deadly effect on the patient. Additionally, overheating can also create several problems. Overheating of the device can cause discomfort for the patients and also cause the system to fail as well. To address all these safety issues, our device must contain over charging/discharging protection, short-circuit protection, and a proper heat management system to function properly. In addition, the project needs to value safety measurements in order to commercialize. If the safety of clients and patients can not be ensured then the device



will witness a great deal of criticism. It will be notorious for its faults and lack of safety which will hamper its value in the market. On top of that, safety concerns and accidents might also beget legal challenges for us and our project.

#### **6.2.4 Legal**

Laws protect our general safety and ensure our rights as citizens against abuses by other people, by organizations, and by the government itself. We have laws to help provide for our general safety. Yet, legal binds are the barriers for such a project when thought solely from a perspective of development. However, legal considerations must be taken whenever developing a system for public use as the developers or the manufacturing company can be held responsible if unfortunate and unexpected incidents occur. On top of that, legalities are most important to ensure the safety of clients.

Accidents can be caused due to system failures such as overheating, compromised components, instability in the system and for many other reasons. If any sort of failures results in an accident for the user which incurs injuries then the user may hold the provider responsible. Even more, users might file cases such as damage and compensation cases or criminal cases in extreme situations. Henceforth, we need to address such systematic issues while developing this project and provide many disclaimers of sorts. Since our project is essentially a medical gadget, it needs to abide by the regulations as per the Health Ministry of Bangladesh. The health ministry has set regulations, processes, and standards by which medical equipment can be manufactured. In order to commercialize our project, we will need to perform various tests and developments so that we can reach the level of standard that is set by the ministry.

#### **6.2.5 Cultural**

Any new innovation brings about massive cultural change where it presides. The impact of technology has seen many advantages along with disadvantages. Engineering solutions often pay less heed to future consequences as it is difficult to predict the response of people in future. However, any innovator must address the cultural impact at large before continuing with development.

The medical culture is becoming more and more dependent on technology as time progresses. Our project will diversify the medical field of Bangladesh immensely as it will incite medical innovation towards the aid of our people. Although modern technologies have dismantled our conventional methods of performing different activities, technological advancement is improving these kinds of activities in terms of efficiency and convenience. Moreover, this system will not only impact the medical culture but the culture of the nation at large as automated systems will become more reliable and available. People will want automation in every aspect of life. Despite its promising rewards, automation might create delirious notions about health as well. It is observed that with ease created through technology there has been a significant increase in laziness. To add, health standards have also plummeted since the dawn

of the technological era. In conclusion, we might digress from our ultimate goal of achieving better health conditions. Thus, all aspects need to be addressed properly when developing and using this device.

### **6.3 Evaluate the sustainability**

Sustainability consists of fulfilling the needs of current generations without compromising the needs of future generations, while ensuring a balance between economic growth, environmental care and social well-being. The significance of sustainability in any aspect of society and environment is predominant compared to the short-term benefits. In order for the continuation of humankind and of future generations, sustainability is one such matter which presides over any requirement or need.

Engineering solutions are of no exception in regards to sustainability. Since engineering projects use different types of manufactured materials and technologies, they impose a major question about sustainability in regards to the environment and society. Mankind has exploited the environment through the negative use of engineering and have begot massive environmental issues upon themselves. The environmental challenges faced today are the results of overlooked sustainability factors of previous engineering solutions. Sustainability is more important now than ever before if we want to continue the existence of our race. Solutions to engineering problems have not only created environmental issues but also societal problems such as cyber-attacks, ranged weapons, nuclear weapons etc. Despite the complexity of predicting how an innovation will affect environments and societies, it is up to the innovators to do so for the sake of sustainability.

In order for our project to be sustainable, we must ensure a number of factors such as recyclability, durability, reliability, safety etc. Our system, if not fully, will be partially recyclable. The majority percentage of components are made of plastic materials which can be reused. Also, metal gears in the MG996 servo motors are recyclable as well. Moreover, we must ensure the device is durable and reliable for longer periods. Achieving a long-life span for the device will go a long way in ensuring sustainability as fewer materials will be needed for replacement. Just as any other electronics, this is indifferent to nature and environment which will cause a certain amount of harm but that can be replenished with mindful eco friendliness. Furthermore, our device is aimed at improving the health of users and mobilizing a large number of people who otherwise would be paralyzed. Providing proper motivation along with the device can enable a large number of people to be conscious of the harm that has been caused to the environment for their betterment. Repair services for the device will also enable products to be reused rather than destroyed.

## **6.4 Conclusion**

It is important to be mindful of the impacts that our project may have in terms of environmental, societal, cultural, legal, health and safety. The system can only be successful when such factors are not only considered but addressed thoroughly. On the other hand, sustainability is also a vital prospect in development of our project. In this fragile ecosystem that is on the verge of instability, it is most important to seek sustainable solutions that will ensure a better future for everyone.

## **Chapter 7: Engineering Project Management. [CO11, CO14]**

### **7.1 Introduction**

Engineering project management is a complex and dynamic field that requires an understanding of the technical, project management, and business aspects of engineering projects. It involves managing the overall budget, timeline, resource allocation, and quality assurance for engineering projects. It requires careful planning and analysis to achieve project goals, including the integration of the various disciplines and stakeholders involved. Additionally, strong communication and collaboration skills are essential to ensure the project is delivered on time and within budget. Engineering project management is a critical component of the engineering process, ensuring the successful completion of projects while meeting the needs of the customer.

### **7.2 Define, plan and manage engineering project**

There are many steps involved in creating a successful engineering project. It requires well-managed plans and strong partnerships with other departments or teams. The first step towards managing any complex engineering project is defining the scope of it and understanding its timelines, budget, goals, resources and scope. The project scope includes the products or services to be created along with precise specifications for fulfilling the objectives of the project. In order to plan the engineering phase effectively one needs to take into account some other factors like group work, stakeholder consultation, selection of tools for production purposes and technical mistakes that could be potentially prevented by implementing countermeasures from the start. The technical mistakes that could potentially occur due to mismanagement are -

- Lack of planning and understanding the project scope, time lines, budget and goals.
- Lack of contingency plans in case there is a change in the project or if any risks or changes to the project occur during its execution.
- Inadequate budgets allocated for projects along with failure to estimate cost accurately leading to higher unexpected expenses when it comes to production purposes.

The selection of tools for production purposes is also an important factor to consider. Using a tool that is not suitable for the project can lead to technical problems.

Table 7.1: Gantt chart

Project timeline												
	Task	Responsible members	Feb	Mar	Apr	May	June	July	Aug	Sept	Oct	Nov
FYDP-P	Topic selection	Fahin, Ashraf, Salman, Sajidul	█									
	Research & documentation	Fahin, Sajidul, Ashraf, Tawsif	█	█								
	Design and approach	Fahin, Sajidul		█	█							
	Code & constraint analysis	Ashraf, Salman		█	█	█						
FYDP-D	Software simulation	Fahin, Ashraf, Sajidul, Salman				█	█	█				
	Component analysis & calculation	Fahin, Ashraf, Sajidul, Salman				█	█	█	█			
	Experimental analysis	Fahin, Ashraf, Sajidul, Salman							█	█	█	
FYDP-C	Prototype building	Fahin, Ashraf, Sajidul, Salman							█	█	█	
	Control setup	Fahin, Ashraf, Sajidul, Salman							█	█	█	█
	App buildup	Fahin, Ashraf, Sajidul, Salman								█	█	█
	Testing and analysis	Fahin, Ashraf, Sajidul, Salman									█	█
	Final documentation	Fahin, Ashraf, Sajidul, Salman										█

### 7.3 Evaluate project progress

Evaluating project progress involves assessing how closely the project is meeting its objectives or deliverables. This includes looking at the project's timeline, budget, scope, and quality. Factors such as communication, risk management, stakeholder engagement, and resource management should also be considered. Metrics and measurements should be used to track the project's progress and identify any areas for improvement. Additionally, it is important to regularly evaluate and adjust the project's plan to ensure its successful completion.

Table 7.2: Project progression breakdown

Progress and timing	Working Progress
Topic selection Process 24-02-2022	The topic selection for a final year design project is an initial step towards whole year planning. It is a tedious process of researching, gathering knowledge, and finding a focus to work on. So, it's important to find a good topic for the project. It is also important to know that the design process should be focused on solving a real-world problem. And it also needs to be specific enough so that you can create a clear goal of what you want to achieve.

<p>Topic discussion 3-03-2022</p>	<p>The process of selecting a topic for a final year design project can vary depending on the specific requirements of the program and the interests of the student. To achieve this, published papers are enough to compare simulation possibilities, and the simple problem can be solved by using software freely available on the Internet.</p>
<p>Topics Idea 5-03-2022</p>	<p>The papers are about post-stroke patients' paralysis. It is about the effect of post stroke on people's lives and how it can affect their daily routine. It also talks about the various ways to deal with this kind of situation like physical therapy, occupational therapy, and speech therapy.</p>
<p>Paper Selection 07-03-2022</p>	<p>The paper aims to discuss the use of simulation tools and design principles in stroke rehabilitation. The discussion is based on the current literature and some industrial work done on post stroke rehabilitation. We selected mainly 3 journal papers that are published in IEEE. We mainly looked at the design approaches of these papers.</p>
<p>Project Concept Draft 08-03-2022</p>	<p>The project draft is a document which presents the basic idea of the project and its implementation. It should be written in a concise way and highlight the key features of the project. The draft should also include a slide for presentation to make it easier for the team to understand what is being presented. We submitted our project concept draft to our respective ATC panel and by their given feedback we started working on the final draft.</p>
<p>Revising The Project 18-03-2022</p>	<p>The final draft of the project starts with a recheck of the concept note. This is to ensure that all the details and requirements have been captured. It also includes a review of the project timeline, milestones, and deliverables. Before submitting the final draft, we rechecked it and improved the draft.</p>
<p>Draft 4-04-2022</p>	<p>Draft notes should be written in a way that is clear and concise. Drafts are often used in the design process to help designers refine their ideas and make sure we are on the right track before moving onto the final design.</p>

Draft Correction 12-04-2022	After receiving feedback and corrections from the appropriate ATC panel, we updated it.
Final Project proposal 09-05-2022	The proposal must be of the highest caliber and should amply demonstrate our effort and diligence. An error-free, comprehensive, accurate, and well-structured report should be among the final project submission's anticipated results. It ought to reveal the student's knowledge of the material as well as their capacity for analysis and problem-solving. Furthermore, we must be prepared to defend the logic behind our new findings.
Simulation Tools Selection 17-06-2022	Started looking for appropriate simulation tools, such as MATLAB and Proteus.
1st design simulation 24-06-2022	The first design using micro-DC motors was simulated on Proteus.
2nd design simulation 26-06-2022	The second design using linear actuator was simulated on Proteus too.
3rd design simulation 27-07-2022	Pneumatic system simulation was completed in MATLAB where we got the output response time.
Simulation comparison 30-06-2022	We compared two different simulation types carried out in Proteus based on the simulation results. There were no similar results when we performed the third design on a different simulation tool.
Single simulation platform 1-07-2022	We were advised to analyze our multiple designs using one single simulation platform to avoid different solving algorithms.
Simulation 15-07-2022	Choosing MATLAB as our preferred simulation tool to compare our all three multiple designs.
Simulation problem 26-07-2022	Fixing design problems in Simulink.
3D design 5-08-2022	Started to design the model in SOLIDWORKS.
3D printing 22-08-2022	We sent the design to get 3D printed.
Wrong printing outcomes 30-08-2022	While mounting all the 3D printed parts, we discovered sizing problems of some specific parts.
Reediting the CAD 7-09-2022	We continued to use our knowledge to try to resolve the sizing problem. After some time, we attempted to obtain assistance from the open-source platform to reduce the size and make our design more compact.
Component specification 11-09-2022	Choosing components for the project according to the specification,

Code 19-09-2022	Writing codes for both the Arduino.
Debugging the Code 30-09-2022	Debugging the code and addressing the bugs we found.
Hardware complexity 14-10-2022	We figured out how to adjust the PWM signal to effectively synchronize with the code for proper operation.
Change in component 25-10-2022	Due to a component shortage, we weren't able to find all the components we wanted. As time passed, we were able to replace some of our components, but we are still lacking an antenna which can produce a strong signal for communication.
Hardware setup failure 30-10-2022	In between the testing of components, we found out some components that were faulty.
Finding a suitable glove 15-11-2022	We went on to find a free size glove to put on the 3D printed hand exoskeleton.
Final Setup	The final prototype was finished.

## 7.4 Conclusion

Engineering project management is an important part of any engineering project, as it ensures that a project is completed on time, within budget, and to the highest quality. It is a complex process, involving multiple disciplines and stakeholders, and requires experience, knowledge and skill to successfully manage engineering projects. By having a clear understanding of the project goals and objectives, the project manager can ensure that all the stakeholders are working towards the same goal and that the project is completed to the highest possible standard.

In our scenario, we managed our three-semester project with good communication and a well-defined plan. To accomplish our goals and control our costs, we were quite laser-focused. Moreover, we considered expanding the concepts; for instance, we planned to create an app that will display a summary of weekly exercise. However, due to time constraints, we were unable to complete it; as a result, we will work on that in the future.



## Chapter 8: Economical Analysis. [CO12]

### 8.1 Introduction

This section will discuss the importance of analyzing the economical aspects of a given project. It is important to analyze the economical aspects of a given project before making any decision. This section will discuss some examples where analysis would help make better decisions. The first factor that needs to be considered when analyzing the economics of a project is the scope. The scope of a project is its size, complexity and duration. The second factor is the cost of the resources used for the project. This includes labor, materials, equipment and subcontractors. The third factor is the cost of capital used in financing the project.

### 8.2 Economic analysis

An economic analysis of a hand rehabilitation device would look at the cost of the device and its associated services, such as training and maintenance, in comparison to the potential benefits it could provide. It would also consider the cost of alternative solutions to the same problem and the cost-effectiveness of the device. Factors such as the health benefits it could provide and its potential to improve quality of life would also be taken into consideration. Ultimately, an economic analysis can provide a comprehensive view of the value of a hand rehabilitation device, helping to make informed decisions regarding its purchase and use.

For our budget calculation, we have used the website RoboticsBD.com. All the components we are going to use in our optimal design solution can be obtained from here. We are taking many aspects into consideration, such as maintenance cost, replacement of components, etc. This website is a reliable one currently in the context of the Bangladeshi market.

Table 8.1: Expected component price list and overall cost of the system

Component	Price (BDT)
Battery(7.4V)	699
Microcontroller (ATmega 2560)	1630
Glove(3D printed)	3000
MG90S Servo Motor(4x)	1500
2.2 Inch Flex Sensor	1250
Jumper Wires	100
Miscellaneous Cost	2000
Total = 10180 BDT	

This was our analysis of expected costs to build the device, but as time went on, price of the components also changed as well as unprecedented costs also occurred, and the final expenses ended up being a little higher than what we had anticipated.

Table 8.2: Component price list and overall cost of the system

Component	Price (BDT)
Battery 7.4V(2x)	780
Microcontroller (Arduino Uno_ 2x)	2100
Glove (3D printed)	3600
MG996R Servo Motor(5x)	2200
2.2 Inch Flex Sensor(5x)	6250
Jumper Wires	100
Miscellaneous Cost	2000
Total = 17030 BDT	

Our approximate budget was determined by the costs of particular components required. However, in order to make our design more flexible, we made lots of changes. As a result, there is a significant discrepancy between the expected and actual budget amounts.

### 8.3 Cost benefit analysis

Cost benefit analysis is a process used to evaluate a project or program in terms of its potential costs and benefits. In the case of a hand rehabilitation device, the cost benefit analysis would involve assessing the potential costs of purchasing and using the device, such as the cost of the device itself and any associated installation, maintenance, and operational costs. The benefits of using the device would be evaluated in terms of the expected improvements in hand rehabilitation, such as increased range of motion, improved strength, and improved dexterity. The cost benefit analysis would also consider any associated indirect costs and benefits, such as the costs of lost productivity due to injury, or the benefits to the patient of improved quality of life. Ultimately, the cost benefit analysis would be used to determine whether the potential costs of using the device are outweighed by the expected benefits. The cost benefit analysis for our project also considers any risks associated with the use of the device, such as the potential for injury or adverse reactions due to the use of the device. Finally, the cost benefit analysis would consider any potential long-term benefits or costs associated with the use of the device, such as the potential for improved patient outcomes or the potential for increased health care costs in the future.

To further illustrate, our device might incur injuries which is a negative aspect for the cost benefit analysis of this project. Since it is an electrical system, it is bound to fail at some point which may or may not result in the injury of the patient. Moreover, the device will also have maintenance costs in future which is another drawback. Furthermore, the device might not meet the patient's expectations in terms of comfort and satisfaction which may lead to a decrease in its effectiveness. Again, the device might not meet the patient's expectations in terms of

comfort and satisfaction which may lead to a decrease in its effectiveness. Finally, there are certain risks associated with the device. For example, due to its complexity, improper use of the device may lead to injury. Furthermore, the device might not be compatible with certain medical treatments, which might lead to adverse effects. Overall, the use of a medical device can be beneficial for patients in terms of providing relief from certain medical conditions. However, there are certain risks associated with the use of such devices which should be considered before using them.

On the other hand, the hand rehabilitation system will be a onetime investment that will aid in the improvement of health in the long term. Additionally, the device is bound to make the quality of life for a paralyzed patient much better. Moreover, future health care costs might increase which will in turn make physiotherapy sessions more expensive. This system helps to reduce the cost of physiotherapy sessions as the patient can do it at home. Overall, the hand rehabilitation system can be beneficial for everyone in the long run by improving the health of those with paralysis and reducing the cost of healthcare. The device is a one-time investment that will ultimately help people with paralysis to regain movement and improve their quality of life.

#### **8.4 Evaluate economic and financial aspects**

The economic and financial aspects of a hand rehabilitation device depend on the type of device, the cost of production, and the market for the device. The cost of production includes the cost of materials, labor, overhead, and any other related costs. The market for the device includes the potential users and the demand for the device.

The economic and financial aspects of a hand rehabilitation device can be evaluated by calculating the cost of production, the pricing of the device, the profit potential, and the return on investment (ROI). The cost of production should be calculated based on the cost of materials, labor, overhead, and any other related costs. The pricing of the device should take into account the market demand and the cost of production. The profit potential should be calculated by subtracting the cost of production from the price of the device. The ROI should be calculated by dividing the profit potential by the cost of production.

The economic and financial aspects of a hand rehabilitation device should also be evaluated based on the potential for long-term success. This includes evaluating the potential for ongoing demand for the device, the potential for new customers, and the potential for positive word-of-mouth. Additionally, the evaluation should consider the potential for competition and the potential for

## **8.5 Conclusion**

To conclude, the economic analysis portrays that the automated glove can be a cost-effective solution for post stroke hand rehabilitation. This analysis has been conducted to determine whether or not this device would be an economically viable solution for post-stroke hand rehabilitation. Moreover, it will be a great investment for the improvements of the patient's long-term health. The development of an Automated Glove for Post Stroke Hand Rehabilitation and Assistance is a cost-effective project that will be beneficial for improving the long-term health of patients who have suffered a stroke. The cost benefit analysis shows that the investment in the project would bring a positive return on investment as the costs of the project are lower than the expected returns. The project is also socially responsible, as it would improve the quality of life for those who have suffered a stroke. Therefore, the Development of an Automated Glove for Post Stroke Hand Rehabilitation and Assistance is a worthwhile investment that will bring a positive return on investment, provide social benefits, and improve the long-term health of those affected by a stroke.

## **Chapter 9: Ethics and Professional Responsibilities CO13, CO2**

### **9.1 Introduction**

Ethics play a crucial role in this endeavor because it incorporates physiotherapy. Making a low-cost hand rehabilitation gadget available to everyone is one of this project's main goals. Because it is uncommon in our nation for therapeutic devices of this type to be used, professionals in the medical field must familiarize themselves and the general public with it. Additionally, since stroke victims will utilize this gadget, ensuring its dependability and safety should be a top priority. Preventing the patient from experiencing any discomfort is important. Furthermore, we have a responsibility to tell the consumer sufficiently about this product. First, individuals should be informed about the concept of an automated hand rehabilitation system so they can deliberately choose whether or not to embrace it. When we first begin human testing of our system, we require test participants' permission. Additionally, we must make sure that the system data is accurate to prevent any fraud that can reduce the return on investment for commercialization. This type of cheating would undoubtedly obscure our project's primary goal, which is to offer crippled patients' affordable rehabilitation.

### **9.2 Identify ethical issues and professional responsibility**

Now, we will explore the ethical issues and professional responsibility regarding the development and implementation of hand rehabilitation systems. Our hand rehabilitation system is a micro-controller-based device designed to provide therapy to individuals with upper extremity impairments. As this device may become more prevalent in the healthcare industry, it is important to consider the ethical implications of their use. This section will discuss the potential ethical concerns associated with the use of hand rehabilitation systems, as well as the professional responsibility of those involved in the development and implementation of such systems. Additionally, we will consider the ethical implications of using the technology for research purposes and the responsibility of the therapist to ensure that the system is being used appropriately. Ultimately, we will try to provide an overview of the ethical issues and professional responsibility in the field of social, health, legal and culture concerning the use of hand rehabilitation systems.

#### **9.2.1 Social**

Considering social issues are unavoidable in the development of a hand rehabilitation system glove. This is because the glove must be designed to help those with physical disabilities, a population of people that are often marginalized and underserved. Professional responsibility requires that the glove be designed with the utmost attention to user experience and safety by giving users an easy to use and reliable product.

Additionally, it is important to ensure that the glove is affordable, accessible, and that it can be used by users of all socioeconomic backgrounds. Besides, while testing the hand rehabilitation system, patients may also develop feelings of self-consciousness while wearing these devices.

Thus, it is essential that we are aware of these potential complications in order to effectively manage patient's responses to using these devices and patients' personal data should be protected to ensure confidentiality. Finally, the design should incorporate feedback from both the medical community and the disabled community to ensure that the project meets the needs of both groups.

### **9.2.2 Health**

Our hand rehabilitation device was created with the goal of reducing post-stroke patients' physical disability, which is primarily concerned with the user's health. Health issues can range from minor to severe, and can have a major impact on a person's daily life. In order to help those suffering with physical disabilities and health issues, developing a hand rehabilitation system glove can be a great way to assist in physical rehabilitation. That is why considering ethical health issues are of paramount importance along with professional responsibilities when developing a hand rehabilitation system glove. First priority is that the glove must be designed to ensure the safety and well-being of the user.

To build a hand rehabilitation device, that device must be made of materials that are non-toxic and hypoallergenic, and it must be tested for the safety of the user in terms of potential electrical, mechanical, and chemical hazards. It is important to ensure that the glove does not lead to any unintended risks, such as injury or infection. Additionally, this device would be designed to provide support and gentle pressure to the hand while also providing sensory feedback and motion tracking. Moreover, the glove would be equipped with sensors that could track and measure an individual's progress. Furthermore, the glove should be designed with the user's best interests in mind, taking into account any potential physical or psychological side effects, and ensuring that the user is able to use the glove with minimal assistance. With this device, people can help themselves manage their own health, and become more independent and self-sufficient. Developing a hand rehabilitation system glove is a great way to help those with physical health issues and disabilities.

### **9.2.3 Legal**

Laws are a way of keeping order in a nation and preventing people from committing crimes and ensuring that all citizens are treated fairly and with respect. This is why the laws of a country provide a framework that allows citizens to be treated equally and fairly in terms of their rights and responsibilities. Developing a hand rehabilitation system involves a number of legal considerations. This includes adhering to all laws, regulations, and standards as set forth by the regulations as per the Health Ministry of Bangladesh. It must comply with any applicable patent laws and intellectual property regulations, as well as any relevant medical device regulations.

First, it is important to ensure that all intellectual property rights are respected, and that the design and production of the glove meet the highest ethical standards. Moreover, it is also important to consider the potential risks associated with the use of the glove, and to mitigate

them through proper safety protocols. Besides, the manufacturer must have sufficient liability insurance to protect against any potential legal claims arising from the use of the glove. The manufacturer must make sure that any marketing materials comply with applicable advertising standards and regulations. If the system incorporates any copyrighted materials, such as software code or images, then permission must be granted from the copyright holder before using them. This project must adhere to the rules set forth by the Bangladeshi Health Ministry because it is essentially a medical device. Medical equipment can only be produced in accordance with rules, procedures, and standards established by the health ministry. Finally, it is important to ensure that the glove has been tested and approved by medical professionals and that the glove is compliant with all applicable standards.

#### **9.2.4 Cultural**

A society's laws, morals, customs, ethics, and behaviors make up the complex whole of culture. From society to society, culture differs. When a new innovation is introduced that might have an impact on certain cultural aspects of that particular society. Innovation can also cause a shift in attitudes and beliefs. People may become more accepting of new ideas and methods of living, or they may become more resistant to change. It can also lead to a transformation of the way we interact with each other and the environment, leading to a more sustainable lifestyle. Hence, it is essential to address cultural issues before developing any types of engineering tools or gadgets.

When developing a hand rehabilitation system, it is important to consider cultural issues and responsibility. Depending on the culture and context in which the system will be used, certain design choices may be more appropriate than others. For example, in some cultures, technology is seen as more of a luxury item than a practical tool, so the design of the gloves should reflect this. In other cultures, a more utilitarian design may be preferred. Another important factor to consider is the impact that the system may have on user dignity and autonomy. In some cultures, physical impairments can be seen as a source of shame and embarrassment, so care should be taken to ensure that the system does not cause further stigma. Moreover, we must consider the various cultural backgrounds of the users of the gloves, as well as their expectations, experiences, and preferences. Hence, designing the gloves to be gender neutral, as well as providing users with a choice of colors and materials to suit their individual needs. Some users might feel that wearing these technologically advanced gloves would be disrespectful to their cultural norms because wearing artificial gloves may make users feel self-conscious about their disability, users might also feel embarrassed. Finally, it is important to ensure that the system is accessible to all users, regardless of their financial means. This could be achieved by providing the system at a low cost, or through providing subsidies or other forms of financial assistance. Ultimately, developing a hand rehabilitation system requires thoughtful consideration of cultural issues.

### 9.3 Apply ethical issues and professional responsibility

Our project is about developing a hand rehabilitation system which is based on the principles of neuroscience and on the idea that the brain can be trained to use other parts of the body, such as hands, as a substitute for lost function due to injury or disease. Therefore, ethical consideration plays a vital role here and we need to be aware of any potential ethical issues that we may encounter and take professional responsibility to make sure that causes any harm in this process. Throughout the project development phases, we considered various important factors to ensure user safety. We developed the project by considering social, health, legal and cultural ethical issues and professional responsibility. Though, we identified a number of issues for each aspect but while working on the project it is quite hard to apply all of these issues at this stage. Now, in this section we will demonstrate the ethical issues along with potential weakness and strength of our project that we have applied throughout the whole development phase.

- **Social:** We first take accessibility and affordability into account for this section because we want users from all socioeconomic backgrounds to be able to use it. For this, we took into account both the size of male and female hands. In order to ensure that this does not discriminate against any gender. We understand the importance of budget and user consent, so we have taken steps to ensure that our design is cost-effective and user-friendly. We have also been working closely with user experience experts to ensure that our prototype meets the highest standards of usability. Additionally, we plan to conduct thorough beta testing to ensure that our design meets users' expectations and that the product is of the highest quality.
- **Health:** As our device is primarily focused on the medical industry, anything that could cause the patient any discomfort should be avoided. To prevent patients from coming into contact with toxic or highly allergic materials, we investigated the materials that would be used for the gloves during the development phase. We are also concerned about the weight of the glove so the user does not get hurt or get infected. Additionally, the servo motor's mechanical system is straightforward, making it possible for anyone to adjust the wire as needed when an accident may occur. However, we are not yet prepared to guarantee the user's safety in all respects due to limitations in a number of different areas like the mechanical side of the project because it needs more 3D design precision for the user's comfort. This project requires additional development time.
- **Legal:** We considered all laws, rules, and standards outlined by the regulations as per the Health Ministry of Bangladesh when developing our hand rehabilitation system at all stages. Additionally, we ended up going to a medical physiotherapy facility and got some advice there about our suggested design. Overall, our interaction with the medical physiotherapy facility was extremely helpful in guiding us to create a device that would



meet the needs of the user and follow the rules set by the Health Minister. With their help, we were able to make sure our design was safe, effective, and beneficial for the user. We understand that code from open source platforms is distributed under a license which may have certain restrictions and requirements, and we do not violate these terms and conditions when using the code. We also make sure that any modifications we make to the code are clearly documented, and that the code is not used for any malicious or unethical purpose.

- **Cultural:** Our team addressed cultural issues while designing our product to ensure that it did not offend any individuals or groups' beliefs. For people of all backgrounds to accept the modernization of technology, we kept our design straightforward and simple. We kept in mind, the gloves' design should be gender-neutral, and users should have a selection of colors and materials to suit their preferences. Moreover, we need to get consent from test subjects when we initially start human trials of our system. Additionally, we also plan to provide users with practical demonstrations to illustrate the device's features and functions. However, it can be difficult to show illiterate and superstitious people how to use this kind of technology, so we also require some expert training sessions because of this.

#### **9.4 Conclusion**

To sum up, making the device cheap, familiarizing people with easy and cheap physiotherapy, training healthcare professionals trained in this new kind of therapeutic device, and making sure of developing a reliable and easy-to-use device should be our primary goals for this project. The development should ensure that the device is safe, effective, and does not cause any harm or discomfort to the user. The design must also take into account the ethical considerations, such as privacy and autonomy, of the users. Furthermore, we should consider the potential legal implications of the device, such as liability and safety. Finally, the development process should be completed with the utmost integrity, to ensure that the device provides the best possible outcome for the users.

## **Chapter 10: Conclusion and Future Work.**

### **10.1 Project summary**

The development of an automated glove for post-stroke hand rehabilitation and assistance is a major breakthrough in the field of medical technology. This glove is designed to help stroke victims regain the dexterity in their hands, allowing them to perform basic tasks such as grasping and releasing objects. In order to analyze progress and evaluate the performance of our system designs, we selected contemporary simulation tools. To validate our system, MATLAB displayed the output responses. In our MATLAB simulation, we observed that designs based on "pneumatic bending actuator" and "slide spring mechanism" occasionally produce unwanted current spikes in response to input.

Here, we have to use two gloves, one is for controlling and another is for the patient's hand movement. RF transmitter and RF receiver has been used for wireless communication through the two microcontrollers. Since our proposed gloves still is in the development stage, many aspects still need to be improved in order to make our project more compact.

The high cost and absence of such rehabilitation devices, along with necessary materials or resources, were the project's main challenges. It is very difficult to develop a device that is both affordable and effective. First off, some parts are unavailable in our country. As a result, we need to change the designs of some of our systems in order to cut costs. In order to make the device more adaptable and precise, we also swapped out some of the components for some other effective ones.

We looked at three different designs when developing this project, and after examining the data from our simulations, we determined that our "3D printed soft exoskeleton with micro-DC motor" is the best option to use when creating our prototype. However, for better control and to avoid technical challenges, we have to switch from the DC motors to servo motors.

Initially, we thought about using soft plastic material (TPU) for 3D printing, but we had to switch to PETG (polyethylene terephthalate glycol) due to budget reasons, stiffness, and fulfillment requirements. We came to realize that the hardware development phase faces numerous challenges and changes from the initial proposing stage. Most common constraint is to make the device a compact pack to demonstrate, but because of 3D printing's mechanical issues, we need more time. Moreover, for confirming validation while testing the prototype we notice there are time delays of the RF module, signal commands and a lag of finger movements. To overcome this, we need to give more time on the validation stage to make it precise. To ensure the accuracy of the validation stage, we can use a timer to measure the delays of the RF module and signal commands, as well as the lag of finger movements. This will allow us to adjust the timing of the validation stage to ensure that all signals are received and processed correctly.

Additionally, we can use an automated testing tool to measure the accuracy of the prototype in various scenarios, such as different speeds and distances. This will help us identify any potential problems with the prototype and make sure that it is working as expected before it is released. To conclude, the advancement and automation of the physiotherapy sector going forward, as well as our familiarization with these kinds of cutting-edge technology in our nation, are among our main goals. Our system needs to reduce the price, ensure portability, and most importantly, incorporate assistive functions because hand therapy devices are unavailable in our country and expensive imported devices.

## **10.2 Future work**

The development of an automated glove for post stroke hand rehabilitation and assistance is an important area of research and development. Post-stroke hand rehabilitation and assistance is a crucial part of stroke recovery. Right now, we are in the hardware prototype development phase, so our development is not perfect yet. There are many aspects of this project that we can improve in the future to meet up our goals that we set from the very beginning. The glove will be designed to provide a range of movement therapy, including passive and active exercises, as well as sensory feedback, so it will be designed to be used by stroke survivors in their homes, with minimal assistance from caregivers or therapists. The modification of the glove will be based on existing research, as well as feedback from stroke survivors and therapists. Therefore, this section will demonstrate some future works that we are looking forward to doing in order to create a flawless and precise device that follows our suggestion.

### **i) Utilize finite element analysis to identify the areas of stress and strain in the device and optimize the design to maximize its strength and reduce weight**

Finite element analysis (FEA) is a powerful tool for identifying areas of stress and strain in a device, as well as optimizing the design to increase strength and reduce weight. FEA can help to identify weak points in the design, and inform decisions on materials, shape, and structure that can help to make the device stronger and lighter.

First, the device must be modeled using a finite element software package. This requires creating a mesh of the device, which is a network of small elements that captures the geometry of the device. Once the mesh is created, the physical properties of the device must be input (e.g. material, temperature, etc.).

Next, the finite element software is used to simulate the loading conditions and boundary conditions of the device. This will generate a stress and strain map of the device that can be used to identify areas of high stress and strain and weak points in the design. The results of the simulation can then be used to optimize the design. Options include altering the geometry of the device, changing the material, or adding additional reinforcements or supports.

Once a new design is implemented, the simulation can be repeated to validate the changes and ensure that the design meets the desired strength and weight

### **ii) Electrical component development**

The electrical component development for our automated glove will involve developing the SMD components and the associated electronics. The circuit board should be designed in such

a way as to integrate sensors, motors, and other components necessary to create a functioning automated glove. Moreover, we can improve the signal transmission of the system by providing advanced RF transmitter and receiver so that latency can be reduced. We can shift the Arduino uno to Arduino nano so that device would become more compact and lightweight. The newer version of nano is capable of running at higher clock speeds, which can be beneficial for more complex tasks. The smaller size and more powerful processor of the Nano can help make the glove more compact and efficient. Furthermore, the Nano has built-in wireless capabilities, which can be used for Bluetooth communication between the glove and a smartphone or tablet. This can be extremely useful for monitoring the patient's progress and controlling the glove remotely.

### **iii) PCB Design**

The first step in designing a PCB for the Automated Glove for Post Stroke Hand Rehabilitation and Assistance is to identify the components that will be used in the design. This includes microcontrollers, sensors, actuators, and other necessary components. After the components have been identified, the next step is to create a schematic diagram of the circuit. This includes connecting the components together and specifying the connections between them. Once the schematic diagram is complete, the next step is to create the PCB layout. This includes placing the components on the PCB, connecting them together with tracks, and adding any necessary components such as capacitors and resistors. Finally, the PCB is tested to ensure that it meets the design requirements.

PCB design will enhance the precision of our device by using proper circuit design and making the device smaller and compact. It will also help in providing better performance and reduce the chances of faults, overheating, and other anomalies. The design also helps in reducing the cost of production and improving the reliability of the device. It also helps in providing enhanced features and functions.

### **iv) Mechanical development**

We can develop a mechanism to allow the glove to move in a range of natural motions. This could include sensors that respond to electrical impulses from the user or a motorized actuator to provide assistance in movement. Moreover, creating a control system to ensure that the glove performs the desired motions safely and accurately. This could include an algorithm that can sense the user's movements and respond accordingly. Furthermore, developing a way to power the glove, such as a battery or a charging system. This would need to be able to provide enough power to sustain the glove's operations for a prolonged period of time. Finally, developing an interface that allows users to customize the glove's movements and settings for their own needs. This would require user-friendly controls and a display to show the glove's current settings.

### **v) Weight reduction with plastic bolt**

For our 3D printed automated glove for post stroke hand rehabilitation and assistance, weight reduction can be achieved by replacing metal bolts with plastic bolts. Plastic bolts are lighter

and cheaper than metal bolts and are just as durable, making them an ideal choice for this application. Additionally, plastic bolts are easier to install and require less maintenance than metal bolts. By replacing metal bolts with plastic bolts, the weight of the 3D printed glove can be significantly reduced, resulting in a lighter and more comfortable device for patients.

#### **vi) Conversion to DC dependent system**

Additionally, we are considering converting the system to an entirely DC system. In order to do this, the existing hardware components would need to be replaced with DC-compatible versions, including the motor, sensors, and actuators. The benefits of converting the system to an entirely DC-based system are that it would provide greater control over the system and its components, as well as increase the overall efficiency of the system. Additionally, a DC-based system would be less susceptible to power fluctuations, and it would be more reliable and durable. Finally, the system would be able to operate at higher speeds and higher output levels than the existing AC-based system. The main challenges associated with converting the system to an entirely DC-based system are the cost and time associated with replacing the existing hardware and software components, as well as the extra power requirements. Additionally, there could be some compatibility issues between the DC-compatible hardware and software components of the system. Finally, the system would need to be

#### **vii) App development**

Our Automated Glove for Post Stroke Hand Rehabilitation and Assistance project will involve the development of an app that is capable of tracking and recording the progress of a stroke survivor's hand rehabilitation in future. The glove will be equipped with sensors to detect the range of motion and muscle activity of the patient, and will be connected to a mobile app that can provide personalized guidance and feedback. The app will be able to provide visualizations and other metrics to track the patient's progress and to provide further guidance. Additionally, the project will involve the development of a database of exercises and activities that can be used in the rehabilitation process. The database will be populated with information gathered from healthcare professionals and other sources, and will be constantly updated with new and improved exercises. Finally, the project will include the development of an automated system to monitor the patient's progress and provide real-time feedback and guidance to the patient.

## Chapter 11: Identification of Complex Engineering Problems and Activities.

### 11.1: Identify the attribute of complex engineering problem (EP)

Attributes of Complex Engineering Problems (EP)

	Attributes	Put tick (√) as appropriate
P1	Depth of knowledge required	√
P2	Range of conflicting requirements	
P3	Depth of analysis required	√
P4	Familiarity of issues	√
P5	Extent of applicable codes	
P6	Extent of stakeholder involvement and needs	
P7	Interdependence	√

### 11.2: Provide reasoning how the project address selected attribute (EP)

P1: Depth of knowledge required: To develop an “Automated Glove for Post Stroke Hand Rehabilitation and Assistance Device” the knowledge of mechanical engineering, electromechanical engineering, computer programming languages, CAD designing and control systems engineering is required to design, develop, and test an automated glove for post-stroke hand rehabilitation and assistance. Moreover, as it involves medical science and neurology, knowledge of neurology and rehabilitation science is also required to design the glove to properly fit and assist post-stroke patients in their rehabilitation.

P3: Depth of analysis required: The depth of analysis required for the development of an automated glove for post stroke hand rehabilitation and assistance depends on the needs and goals of the project. For example, the analysis includes an in-depth look at the anatomy and physiology of the hand, the biomechanics and kinematics of the hand, the medical literature related to post-stroke hand rehabilitation, the available technology and materials for building the glove, and the user requirements. Additionally, the analysis also encompasses ethical considerations, design constraints, and potential risks associated with the device.

P4: Familiarity of issues: The familiarity of issues can be assessed by the generation of multiple design solutions. As we derived different approaches to the same problem we uncovered many familiar and unfamiliar perspectives of the same problem. Moreover, we faced familiar issues within the three proposed approaches. The familiarity of issues associated with the development of an automated glove for post-stroke patients are also varied and depend on the type of stroke and the degree of the patient's impairment. Generally, we had to familiarize ourselves with the types of sensors and actuators that are necessary to measure the patient's range of motion, the design of the glove to provide comfort and support, the software that

would be required to interpret the data and adjust the glove accordingly, and the safety protocols that must be developed to ensure the patient's safety while using the glove. Additionally, we got familiar with the clinical protocols used in post-stroke hand rehabilitation, as well as the regulations and guidelines governing the use of medical devices.

P7: Interdependence: The development of an automated glove for post stroke hand rehabilitation and assistance is a complex endeavor that requires a high degree of interdependence between multiple disciplines, including engineering, computer science, medicine, and rehabilitation. Each of these fields must come together to create an effective and efficient device that can help stroke survivors regain their full hand function and mobility. The engineering and computer science components of the project are essential for creating the actual glove and its software components and the medical and rehabilitation components are important to ensure the safety and effectiveness of the glove.

### 11.3 Identify the attribute of complex engineering activities (EA)

Attributes of Complex Engineering Activities (EA)

	Attributes	Put tick (√) as appropriate
A1	Range of resource	√
A2	Level of interaction	√
A3	Innovation	
A4	Consequences for society and the environment	√
A5	Familiarity	√

### 11.4 Provide reasoning how the project address selected attribute (EA)

A1: Range of resource: The development of our project required a wide spectrum of resources. As it is an automated rehabilitation device it has needed multidisciplinary knowledge. Such as, engineering, computer science, medicine, rehabilitation and physiotherapy. Furthermore, we have resourced knowledge from multiple internet sources to tackle each hurdle. For instance, the programming code for Arduino IDE, designing techniques of SolidWorks software etc. For the mechanical design of the robotic hand, we have used Solid works software. Moreover, we have used Arduino IDE to program the microcontroller to receive and give instructions to the device. Additionally, we have used 3D printing to print the parts of the robotic arm. We have also used MATLAB for developing the schematic for the system. We have used many online resources such as online forums, blogs, and videos to get knowledge regarding the design, programming and testing of the device.

A2: Level of interaction: The level of interaction attributes for developing an automated glove for post-stroke hand rehabilitation and assistance should be designed to provide a high level of interaction between the user and the device. The interaction should be designed to provide a natural and intuitive experience for the user, allowing them to interact with the device with minimal effort and as little discomfort as possible. The level of interaction should also be designed to provide a high degree of accuracy and precision in the user's movements, allowing them to perform complex tasks with the device. Additionally, the level of interaction should be designed to allow for easy calibration and adjustment of the device's settings and parameters, allowing the user to tailor the device to their specific needs.

A4: Consequences for society and the environment: Automated Glove for Post Stroke Hand Rehabilitation and Assistance could help improve the quality of life for stroke patients. The glove could help those with limited hand mobility to regain movement and allow them to perform daily activities more efficiently. Additionally, it provides more accessible and affordable care, allowing stroke patients to receive the necessary rehabilitation at home without having to go to a rehabilitation clinic. This could help reduce health care costs and make rehabilitation more accessible to those who may not be able to afford it. Finally, this project could help reduce environmental impacts associated with hospital visits. Since patients would no longer need to travel to rehabilitation clinics, there will be fewer cars on the roads, which could reduce emissions and help reduce air pollution. Additionally, the project might have negative impacts on the environment as well. Since this device is mainly made of plastic and metal materials, the production of such a device is bound to leave a carbon footprint on the environment.

A5: Familiarity within complex engineering activities is substantial. In any endeavor or project of complex engineering problems, the process can be broken down to 3 steps, i.e Planning, Developing and Executing. Planning is the first and most important stage of any complex engineering activity. The goal of the planning stage is to identify the steps that need to be taken to achieve the desired outcome. This stage involves gathering the necessary data, researching the problem, analyzing the data, and creating a plan of action. During the planning stage, it is also important to consider the resources needed to carry out the activity, the timeline for completion, and any risks that may be associated with the activity. In the developing stage, the plan of action that was created in the planning stage is implemented. This is when the actual engineering work begins. During this stage, the necessary resources are gathered, the project is tested and refined, and the necessary components are built. It is also during this stage that any potential issues are identified and addressed. Once the project is developed, it is time to put it into action. This is the executing stage. During this stage, the project is tested thoroughly and any remaining adjustments are made. Once the project is ready to go, it is released to the public or put into production. The goal in this stage is to ensure the project works as intended and meets all the necessary requirements.



## References

- [1] Yue, Z., Zhang, X., & Wang, J. (2017). Hand Rehabilitation Robotics on Poststroke Motor Recovery. *Behavioural Neurology*, 2017, 20. <https://doi.org/10.1155/2017/3908135>
- [2] Lindsay, M. P., Norrving, B., Sacco, R. L., Brainin, M., Hacke, W., Martins, S., Pandian, J., & Feigin, V. (2019). World Stroke Organization (WSO): Global Stroke Fact Sheet 2019. *International Journal of Stroke*, 14(8), 806–817. <https://doi.org/10.1177/1747493019881353>
- [3] Chakraborty, P. K., Islam, M. J., Hossain, M. S., Barua, S. K., & Rahman, S. (2018). Profile of Patients Receiving Stroke Rehabilitation in A Tertiary Care Hospital. *Chattagram Maa-O-Shishu Hospital Medical College Journal*, 17(1), 9-12.
- [4] Post-Stroke Rehabilitation Fact Sheet | National Institute of Neurological Disorders and Stroke. (2020, April). Ninds.Nih.Gov. Retrieved March 5, 2022, from <https://www.ninds.nih.gov/Disorders/Patient-Caregiver-Education/Fact-Sheets/Post-Stroke-Rehabilitation-Fact-Sheet#technologies>
- [5] Burrone, V., & Graham, L. (2020). Digital Therapeutics Past Trends and Future Prospects. *Digitall Technologies*, 32. Available at: <https://www.evidera.com/digital-therapeutics-past-trends-and-future-prospects/>
- [6] Maciejasz, P., Eschweiler, J., Gerlach-Hahn, K. A survey on robotic devices for upper limb rehabilitation. *J NeuroEngineering Rehabil* 11, 3 (2014). <https://doi.org/10.1186/1743-0003-11-3>
- [7] Prange, G., Smulders, L., Wijngaarden, J., Lijbers, G., Nijenhuis, S., Veltink, P., Buurke, J. & Stienen, A. "User requirements for assistance of the supporting hand in bimanual daily activities via a robotic glove for severely affected stroke patients," 2015 IEEE International Conference on Rehabilitation Robotics (ICORR), Singapore, 2015, pp. 357-361, doi: 10.1109/ICORR.2015.7281225.
- [8] Popov, D., Gaponov, I. & Ryu, J. (2016). Portable Exoskeleton Glove With Soft Structure for Hand Assistance in Activities of Daily Living. *IEEE/ASME Transactions on Mechatronics*. PP. 1-1. 10.1109/TMECH.2016.2641932.
- [9] Chen, T. & Lum, P. S. "Hand rehabilitation after stroke using a wearable, high DOF, spring powered exoskeleton," 2016 38th Annual International Conference of the IEEE Engineering in Medicine and Biology Society (EMBC), Orlando, FL, USA, 2016, pp. 578-581, doi: 10.1109/EMBC.2016.7590768.
- [10] Ueki, S., Kawasaki, H., Ito, S., Nishimoto, Y., Abe, M., Aoki, T., Ishigure, Y., Ojika, T. & Mouri, T. "Development of a Hand-Assist Robot With Multi-Degrees-of-Freedom for

Rehabilitation Therapy," in IEEE/ASME Transactions on Mechatronics, vol. 17, no. 1, pp. 136-146, Feb. 2012, doi: 10.1109/TMECH.2010.2090353.

[11] Kang, B. B., Lee, H., In, H., Jeong, U., Chung, J. and Cho, K. -J. "Development of a polymer-based tendon-driven wearable robotic hand," 2016 IEEE International Conference on Robotics and Automation (ICRA), Stockholm, Sweden, 2016, pp. 3750-3755, doi: 10.1109/ICRA.2016.7487562.

[12] Yun, S. -S., Kang, B. B. and Cho, K. -J. "Exo-Glove PM: An Easily Customizable Modularized Pneumatic Assistive Glove," in IEEE Robotics and Automation Letters, vol. 2, no. 3, pp. 1725-1732, July 2017, doi: 10.1109/LRA.2017.2678545.

[13] Yap, H. K., Khin, P. M., Koh, T. H., Sun, Y., Liang, X., Lim, J. H. & Yeow, C. H. "A Fully Fabric-Based Bidirectional Soft Robotic Glove for Assistance and Rehabilitation of Hand Impaired Patients," in IEEE Robotics and Automation Letters, vol. 2, no. 3, pp. 1383-1390, July 2017, doi: 10.1109/LRA.2017.2669366.

[14] Chakraborty, P. K., Islam, M. J., Hossain, M. S., Barua, S. K., & Rahman, S. (2018). Profile of Patients Receiving Stroke Rehabilitation in A Tertiary Care Hospital. *Chattagram Maa-O-Shishu Hospital Medical College Journal*. 17(1),9–12. <https://doi.org/10.3329/cmshmcj.v17i1.39435>.

[15] Arata, J., Ohmoto, K., Gassert, R., Lambercy, O., Fujimoto, H. and Wada, I. "A new hand exoskeleton device for rehabilitation using a three-layered sliding spring mechanism," 2013 IEEE International Conference on Robotics and Automation, Karlsruhe, Germany, 2013, pp. 3902-3907, doi: 10.1109/ICRA.2013.6631126.

[16] Wang, B., McDaid, A., Biglari-Abhari, M. and Aw, K. C. "Design and development of a glove for post-stroke hand rehabilitation," 2017 IEEE International Conference on Advanced Intelligent Mechatronics (AIM), 2017, pp. 1047-1051, doi: 10.1109/AIM.2017.8014157.

[17] Mohammadi, A., Lavranos, J., Choong, P. and Oetomo, D. "Flexo-glove: A 3D Printed Soft Exoskeleton Robotic Glove for Impaired Hand Rehabilitation and Assistance," 2018 40th Annual International Conference of the IEEE Engineering in Medicine and Biology Society (EMBC), 2018, pp. 2120-2123, doi: 10.1109/EMBC.2018.8512617.

[18] Nicholls, M. E., Orr, C. A., Yates, M. J., & Loftus, A. M. (2008). A new means of measuring index/ring finger (2D:4D) ratio and its association with gender and hand preference. *Laterality*, 13(1), 71–91. <https://doi.org/10.1080/13576500701751287>.

**Appendix**  
**Logbook**

**FYDP (P) Spring 2022 Summary of Team Log  
Book/Journal**

<b>Final Year Design Project (P) Summer 2021</b>			
<b>Student Details</b>	<b>NAME &amp; ID</b>	<b>EMAIL ADDRESS</b>	<b>PHONE</b>
<b>Member 1</b>	Sajidul Islam - 19121093	sajidul.islam@g.bracu.ac.bd	01798650262
<b>Member 2</b>	Salman Ahnaf - 19121022	salman.ahnaf@g.bracu.ac.bd	01754741154
<b>Member 3</b>	Ashraf Shafayet Aditya - 19121005	ashraf.shafayet.aditya@g.bracu.ac.bd	01631492170
<b>Member 4</b>	Md Fahin Fuad Irfa Chowdhury - 19121003	fahin07@gmail.com	01776199988
<b>ATC Details</b>			
<b>ATC 6</b>	<b>NAME</b>	<b>EMAIL ADDRESS</b>	<b>PHONE</b>
<b>Chair</b>	Dr. A. S. Nazmul Huda	nazmul.huda@bracu.ac.bd	
<b>Member 1</b>	Nahid Hossain Taz	nahid.hossain@bracu.ac.bd	
<b>Member 2</b>	Raihana Shams Islam Antara	Raihanashams.antara@bracu.ac.bd	

F = Md Fahin Fuad Irfa Chowdhury, T = Salman Ahnaf, A = Ashraf Shafayet Adittyia, S = Sajidul Islam

<b>Date/Time/Place</b>	<b>Attendee</b>	<b>Summary of Meeting Minutes</b>	<b>Responsible</b>	<b>Comment by ATC</b>
24..02.2022 9.00pm & 11.30pm M.call	F,T,A,S	1.Discussing ideas. 2.Research for a good (FYDP) topic. 3.25/2/22_11.00a m new meeting.	Task 1: F,T,A,S Task 2: F,T,A,S Task 3: F,T,A,S	1.Find a topic which one can complete in one year. 2.Simulation result 3.cost effective.
1.03.2022 9.00am ATC meeting(Offline)	Sajid(s) Ashraf(A)	1.3 Things we have to analyze. 1.1-year time 2. 3 alternative designs. 3. Is it possible with a simulation tool? 4.simple but new and proper paper analysis we have to do. 2.Automatic floor mopping system analysis.(Paper)	Task1: F, T, A, S Task2: F, T, A, S	1.New topic 2.Find some research paper related to this 3.You have to complete it in one year.
5.03.2022 8pm-9.30pm(1) 11-11.15pm(2)  M.call	F,T,A,S	Design and Development of a Glove for Post Stroke Hand Rehabilitation. T1:paper findings T2:paper reading next meeting 10pm(6/3/22) T3: Sharing Idea from Paper	Task1: Sajid Task2:F,T,A,S Task3:F,T,A,S	N/A

6.03.2022 10pm-1040pm M.call	F,T,A,S	T1: Multiple Design Approach T2: Specifications, Requirements, and Constraints T3: Specifications, Requirements, and Constraints T4: Conclusion next meeting 9pm(7/3/22)	T1: Ashraf T2: Fahin, Tawsif T3: Sajid T4: Ashraf	N/A
------------------------------------	---------	---	--	-----

07.03.2022 10pm-12.00am messenger call	F,T,A,S	Project Concept note Writing. 08.03.2022 ATC meeting.(offline)	T1,T2,T3,T4: Done	N/A
08.03.2022 9.15-10.45Am offline meeting ATC	F,T,S	Project concept draft with papers. project selected. 9-03-2022 Concept note presentation. Slide making for presentation.	T1- F,T,A,S	N/A
18.03.2022 10:00-11:27 pm Messenger call	F,T,A,S	Revising our project again.	No, task	N/A
1.04.2022 11:00-11:47pm Meet call	F,T,A,S	Discussion about the project proposal.	Writing their own part common with the concept note.	N/A

9.04.2022 11:00 pm-2.00am Meet call.	F,S	Writing the draft proposal. T1- Design 3, Methodology T2- Safety consideration, Applicable standards	T1- F T2-S	N/A
12.04.2022 10:30am Offline meeting ATC	F,T	Correction in design writing. submitting the draft project proposal.	T1- F,T	1.Make corrections on those marked positions.
18.04.2022 11:00 pm-1.00am Discord call	F,S,T	Expected outcomes, Impact, sustainability, Project plan, Budget. Meeting with ATC at 11am on 19.04.2022	T1- F,S,T,A	N/A

24.04.2022 11:00am Offline meeting ATC	F,T,A,S	Draft proposal checking.		1.Design approaches should be specific. 2.Comparison is needed in the budget. 3.Gantt chart 4.Use some block diagram for representation.
24.04.2022 10:pm-12.30am Meet call	F,T,A,S	Correcting project proposals.	F,T,A,S	N/A
26.04.2022 10.00pm-12.00am Meet call	F,T,A,S	Presentation slide.	F,T,A,S	N/A
27.04.2022 11:00pm-3:30am Meet call	F,T,A,S	Presentation slide and speech.	F,T,A,S	N/A

28.04.2022 10:30-10:47am Meet call	F,T,A,S	Practice presentation.	F,T,A,S	N/A
28.04.2022 11:00am	F,T,A,S	Presentation on Project proposal.	F,T,A,S	
06-05-2022 11:00pm Meet call	F,T,A,S	Project proposal correction.	F,T,A,S	N/A
9-05-2022 10:00pm-11:00pm Meet call	F,T,A,S	Final project proposal.		

## FYDP (D) Summer 2022 Summary of Team Log Book/ Journal

<b>Final Year Design Project (FYDP-D) Summer 2022</b>			
<b>Student Details</b>	<b>NAME &amp; ID</b>	<b>EMAIL ADDRESS</b>	<b>PHONE</b>
<b>Member 1</b>	Sajidul Islam - 19121093	sajidul.islam@g.bracu.ac.bd	01798650262
<b>Member 2</b>	Salman Ahnaf - 19121022	salman.ahnaf@g.bracu.ac.bd	01754741154
<b>Member 3</b>	Ashraf Shafayet Adittyia - 19121005	ashraf.shafayet.adittyia@g.bracu.ac.bd	01631492170
<b>Member 4</b>	Md Fahin Fuad Irfa Chowdhury - 19121003	md.fahin.fuad.irfa.chowdhury@g.bracu.ac.bd	01776199988
<b>ATC Details: ATC 6</b>	<b>NAME</b>	<b>EMAIL ADDRESS</b>	<b>PHONE</b>
<b>Chair</b>	Dr. A. S. Nazmul Huda	nazmul.huda@bracu.ac.bd	
<b>Member 1</b>	Nahid Hossain Taz	nahid.hossain@bracu.ac.bd	
<b>Member 2</b>	Raihana Shams Islam Antara	raihanashams.antara@bracu.ac.bd	



F = Md Fahin Fuad Irfa Chowdhury, T = Salman Ahnaf, A = Ashraf Shafayet Adittyta, S = Sajidul Islam

<b>Date/Time /Place</b>	<b>Attendee</b>	<b>Summary of Meeting Minutes</b>	<b>Responsible</b>	<b>Comment by ATC</b>
16.06.2022 11.30 am ATC meeting(Offline)	F, T, A, S	1.Discussing The Previous semester's ideas.	F, T, A, S	Suggestion on simulation tools and basic steps.
17/6/2022 11.30pm Meet call	F, T, A, S F, T, A, S	Discussing the simulation plans. Tool selection on basic.	F, T, A, S	N/A
23.06.2022 11.30 am ATC meeting(Offline)		Tool selection to design and analyze solutions.	F, T, A, S	Starting with basic simulation.
24.06.2022 11.00 pm Meet call.	F, T, A, S	Starting simulation of design 1	F- Simulation and coding S- Testing and helping in component specification.	N/A
25.06.2022 11.00 pm Meet call	F, T, A, S	Detection of problems in simulation.	A- Trying the simulation. T- Simulation correction.	N/A
30.06.2022 11.30 am ATC meeting(Offline)	F, T, A, S	Try to implement all the simulations on a single platform.	F- Simulation on matlab.	Change the platform (Proteus to MATLAB) if all components are not available.
15.07.2022 10.00pm Meet call	F, T, A, S	Matlab simulation circuit buildup.	Simulation observation of Mathlab circuit.	N/A

21.07.2022 11.30 am ATC meeting(Offline)	F, T, A, S	Simulation problem solving by analyzing the situation.	F- Simulation circuit build up on matlab.	Try to take help from open sources.
23.07.2022 11.30pm meet call	F, T, A, S	Finding Matlab simulation tools	Simulation and checking pre designed system.	N/A
26.07.2022 10.00pm Meet call	F, T, A, S	Discussing problems on Matlab simulation.	N/A	N/A
28.07.2022 11.30 am ATC meeting(Offline)	F, T, A, S	Ethical Issues and Ethical responsibility.		N/A
04.08.2022 11.30 am ATC meeting(Offline)	F, T, A, S	Project management	T1- F,T,A,S	N/A
8.08.2022 11.00pm Meet call	F, T, A, S	Project report writing.		N/A
11.08.2022 11.30 am ATC meeting(Offline)	F, T, A, S	Observing simulation graphs. Draft design report.	Correction of report.	Try to make a 3D view of CAD design.
14.08.2022 9.00pm Meet call	F, T, A, S	Simulation.	F- 3D design. S- Proteus. T-Proteus A-Report correction.	N/A
15.08.2022	F, T, A, S	Simulation result Observation.	Updating all results and writing.	N/A
18.08.2022 11.30 am ATC meeting(Offline)	F, T, A, S	Feedback on draft Report. Simulation result observation on multi tools. Report writing observation.	S-Update report F-Matlab simulation verification of multiple designs.	Analyze the simulation outputs.
25.08.2022 11.30 am ATC meeting(Offline)	F, T, A, S	Final design report submission. Submit on 4.09.2022	N/A	Will give feedback in between a few days.
03.09.2022 5 pm Meet call	F, T, A, S	Correction of the final design report.	Final Correction.	N/A

## FYDP (C) Fall 2022 Summary of Team Log Book/ Journal

<b>Final Year Design Project (FYDP-D) Summer 2022</b>			
<b>Student Details</b>	<b>NAME &amp; ID</b>	<b>EMAIL ADDRESS</b>	<b>PHONE</b>
<b>Member 1</b>	Sajidul Islam - 19121093	sajidul.islam@g.bracu.ac.bd	01798650262
<b>Member 2</b>	Salman Ahnaf - 19121022	salman.ahnaf@g.bracu.ac.bd	01754741154
<b>Member 3</b>	Ashraf Shafayet Adittyta - 19121005	ashraf.shafayet.adittyta@g.bracu.ac.bd	01631492170
<b>Member 4</b>	Md Fahin Fuad Irfa Chowdhury - 19121003	md.fahin.fuad.irfa.chowdhury@g.bracu.ac.bd	01776199988
<b>ATC Details: ATC 6</b>	<b>NAME</b>	<b>EMAIL ADDRESS</b>	<b>PHONE</b>
<b>Chair</b>	Dr. A. S. Nazmul Huda	nazmul.huda@bracu.ac.bd	
<b>Member 1</b>	Nahid Hossain Taz	nahid.hossain@bracu.ac.bd	
<b>Member 2</b>	Raihana Shams Islam Antara	raihanashams.antara@bracu.ac.bd	

F = Md Fahin Fuad Irfa Chowdhury, T = Salman Ahnaf, A = Ashraf Shafayet Aditty, S = Sajidul Islam

## FYDP (C) Fall 2022 Summary of Team Log Book/ Journal

<b>Date/Time/Place</b>	<b>Attendee</b>	<b>Summary of Meeting Minutes</b>	<b>Responsible</b>	<b>Comment by ATC</b>
29.09.2022 9.00 am ATC meeting(Offline)	F, T, A, S	1.Discussing The Previous semester's ideas.	F, T, A, S	Suggestion on project simulation tools and basic steps.
30.9.2022 11.00pm Meet call	F, T, A, S	Discussing the Project plans. Hardware setup and useful component selection..	F, T, A, S	N/A
1.10.2022 10.00 pm Meet call.	F, T, A, S	Simulation setup to test out preferred design.	F, T, A, S	N/A
2.10.2022 11.00 pm Meet call.	F, T, A, S	Component final selection.	F,T-Selecting Final List A,S- Verifying the final list.	N/A
6.10.2022 8.30am ATC meeting Offline	F, T, A, S	Detecting problems with components..	A,s- Finde a budget store for components. T- Online platform price comparison.	1.Verify price on different platforms. 2.Find alternative components as backup.
6.10.2022 11.30 pm Meet Call	F, T, A, S	Finalizing component list.	A- Approximate price list S- 2nd approximate price list.	N/A
8.10.2022 10.00pm Meet call	F, T, A, S	Component Ordering from online	A- Offline shop price verification	N/A
9.10.2022 11.00 pm Meet Call	F, T, A, S	Online orders got canceled due to a shortage of components.	A,S-Offline shopping on 13-10-2022	N/A.
13.10.2022 11.00am	F, T, A, S	Basic component Purchasing.	Going for a setup on 14-10-2022	N/A

Offline				
15.10.2022 10.00am Offline	F, T, A, S	Starting basic setup.	F,S- 3D printing file creation.	N/A
20.10.2022 9.30 am ATC meeting(Offline)	F, T, A, S	3D printing problems and alternative options.	Use open source to learn.	Get a basic design at first.
21.10.2022 10.30 pm Meet call	F, T, A, S	3D printing outcome analysis. Sharing learning platform.		N/A
28.10.2022 11.00pm Meet call	F, T, A, S	Starting 3D design.	T-Hardware setup.	N/A
30.10.2022 11.30 pm Meet call	F, T, A, S	Hardware setup code outcomes and problems.	F-Solving code problem.	N/A
3.11.2022 9.00pm Meet call	F, T, A, S	Solved result and further project plan.	F- 3D design. S- Proteus and code T-Code A-Code Correction.	N/A
6.11.2022 6.00pm Offline	F, T, A, S	Checking all results and hardware setup.	3D design solving. Printing lab finding.	N/A
9.11.2022 6.00 pm offline	F, T, A, S	PLA Filament for 3D printing.	Printing lab cost analysis.	N/A
12.11.2022 9.00 am Offline	F, T, A, S	3D printing.	N/A	N/A
13.11.2022 6.00 pm Offline	F, T, A, S	Assembling 3D design.	F-Resizing faulty components.	N/A
17.11.2022 7.00pm Offline	F,A,T	Printing Resized components.	Correcting mechanical adjustment of the fingers.	N/A
19.11.2022 5.00pm Offline	F,T,S	Assembling hardware setup.	A-Design supporting component purchase.	N/A
20.11.2022 4.00pm Offline	F,T,A,S	Assembling supporting components (RF module)	S,A-Purchasing Flex sensor	N/A

22.11.2022 5.00pm Offline	A	Wearing flex sensors and having a glove to set up the sensor part. Starting Report Writing.	F,T,S-Coding	N/A
26.11.2022 7.00pm Offline	F,T,A,S	Connecting Hardware and Debugging codes.	F,T,A,S-Solving code problems.	N/A
1.12.2022 9,00am ATC Meeting ( Offline )	F,T,S	Updating our results and work progress. Report Writing.	N/A	Try to get a precise finish.
9.12.2022 8.00pm Offline	F,T,A,S	Final testing the setup and codes. Report Writing.	N/A	N/A
14.12.2022 Offline	F,T,A,S	Completing Report and Presentation slide.	N/A	N/A

## Related code/theory

### Transmitter:

```
#include <VirtualWire.h>
```

```
// pin denote
```

```
#define RED_LED 3
```

```
#define BLUE_LED 5
```

```
int thumbpin = A0;
```

```
int indexpin = A1;
```

```
int middlepin = A2;
```

```
int ringpin = A3;
```

```
int pinkypin = A4;
```

```
const int transmit_pin = 12;
```

```
// variable declaration
```

```
int thumbmax,indexmax,middlemax,ringmax,pinkymax;
```

```
int thumbmin,indexmin,middlemin,ringmin,pinkymin;
```

```
int thumbval, indexval, middleval,ringval,pinkyval;
```

```
double thumbtransmit,indextransmit,middletransmit,ringtransmit, pinkytransmit;
```

```
void setup() {
```

```
  digitalWrite(RED_LED, LOW);
```

```
  digitalWrite(BLUE_LED, LOW);
```

```
  vw_set_tx_pin(transmit_pin);
```

```
  vw_setup(2000);
```

```
  Serial.begin(9600);
```

```
  calibration();
```

```
  Serial.println("_____\\nCalibration Done\\n_____\\n\\n\\n");
```

```
  Serial.println("Max: ");
```

```
  Serial.println((String)"Thumb: "+thumbmax+" Index:"+indexmax+"
```

```
Middle:"+middlemax+" Ring:"+ringmax+" Pinky:"+pinkymax);
```

```
  Serial.println("Min: ");
```

```
  Serial.println((String)"Thumb: "+thumbmin+" Index:"+indexmin+" Middle:"+middlemin+"
```

```
Ring:"+ringmin+" Pinky:"+pinkymin);
```

```
}
```

```
void loop() {
```

```
  digitalWrite(BLUE_LED, HIGH);
```

```
// delay(1000);
```

```

//sensor live reading
thumbval = analogRead(thumbpin);
indexval = analogRead(indexpin);
middleval = analogRead(middlepin);
ringval = analogRead(ringpin);
pinkyval = analogRead(pinkypin);
thumbtransmit = map(thumbval,thumbmin,thumbmax,0,180);
indextransmit = map(indexval,indexmin,indexmax,0,180);
middletransmit = map(middleval,middlemin,middlemax,0,180);
ringtransmit = map(ringval,ringmin,ringmax,0,180);
pinkytransmit = map(pinkyval,pinkymin,pinkymax,0,180);

```

```

Serial.print("Thumb: ");
Serial.print(thumbtransmit);
Serial.print("  Index: ");
Serial.print(indextransmit);
Serial.print("  Middle: ");
Serial.print(middletransmit);
Serial.print("  Ring: ");
Serial.print(ringtransmit);
Serial.print("  Pinky: ");
Serial.println(pinkytransmit);
delay(500);

```

```

//Transmission code
double allFingers[] = {thumbtransmit,indextransmit,middletransmit,ringtransmit,
pinkytransmit};
vw_send((uint8_t *)allFingers, sizeof(allFingers));
vw_wait_tx();
delay(500);
}

```

```

//calibration for getting highest and lowest values of fingers

```

```

void calibration() {
digitalWrite(RED_LED,HIGH);
int i;
int calibration_number = 4;
thumbmax=0,indexmax=0,middlemax=0,ringmax=0,pinkymax=0;

```



```

thumbmin=0,indexmin=0,middlemin=0,ringmin=0,pinkymin=0;

int thumbmaxtemp,indexmaxtemp,middlemaxtemp,ringmaxtemp,pinkymaxtemp;
int thumbmintemp,indexmintemp,middlemintemp,ringmintemp,pinkymintemp;
for(i=1;i<=calibration_number;i++){
// Serial.println("starting 3,2,1");

    delay(1000);

thumbmaxtemp=0,indexmaxtemp=0,middlemaxtemp=0,ringmaxtemp=0,pinkymaxtemp=0;

thumbmintemp=4000,indexmintemp=4000,middlemintemp=4000,ringmintemp=4000,pinky
mintemp=4000;
// int thumbval, indexval, middleval,ringval,pinkyval;
    unsigned long time_count = millis()+3000;
    Serial.println("START!!\n");
    digitalWrite(RED_LED, HIGH);
    while(millis(<time_count){

        thumbval = analogRead(thumbpin);
        indexval = analogRead(indexpin);
        middleval = analogRead(middlepin);
        ringval = analogRead(ringpin);
        pinkyval = analogRead(pinkypin);
        if(thumbval<thumbmintemp){thumbmintemp=thumbval;}
        if(indexval<indexmintemp){indexmintemp=indexval;}
        if(middleval<middlemintemp){middlemintemp=middleval;}
        if(ringval<ringmintemp){ringmintemp=ringval;}
        if(pinkyval<pinkymintemp){pinkymintemp=pinkyval;}

        if(thumbval>thumbmaxtemp & thumbval<1000){thumbmaxtemp=thumbval;}
        if(indexval>indexmaxtemp & indexval<1000){indexmaxtemp=indexval;}
        if(middleval>middlemaxtemp & middleval<1000){middlemaxtemp=middleval;}
        if(ringval>ringmaxtemp & ringval<1000){ringmaxtemp=ringval;}
        if(pinkyval>pinkymaxtemp & pinkyval<1000){pinkymaxtemp=pinkyval;}
    }
    thumbmax +=thumbmaxtemp/calibration_number;
    indexmax +=indexmaxtemp/calibration_number;
    middlemax +=middlemaxtemp/calibration_number;
    ringmax +=ringmaxtemp/calibration_number;
    pinkymax +=pinkymaxtemp/calibration_number;

    thumbmin +=thumbmintemp/calibration_number;

```

```

indexmin +=indexmintemp/calibration_number;
middlemin +=middlemintemp/calibration_number;
ringmin +=ringmintemp/calibration_number;
pinkymain +=pinkymintemp/calibration_number;

Serial.println("Max temp: ");
Serial.println((String)"Thumb: "+thumbmaxtemp+" Index:"+indexmaxtemp+"
Middle:"+middlemaxtemp+" Ring:"+ringmaxtemp+" Pinky:"+pinkymaxtemp);
Serial.println("Min temp: ");
Serial.println((String)"Thumb: "+thumbmintemp+" Index:"+indexmintemp+"
Middle:"+middlemintemp+" Ring:"+ringmintemp+" Pinky:"+pinkymintemp);
Serial.println("count done.\nWait for 2sec.\n");
digitalWrite(RED_LED, LOW);
delay(1000);

}

// delay(5000);
// Serial.println("_____ \n\n");
}

```

#### Receiver:

```

#include <VirtualWire.h>
//#include <Servotimer2.h>
#include <ServoTimer2.h> // the servo library
ServoTimer2 pinkyServ,thumbServ,indexServ,middleServ,ringServ;

```

```

double thumb, index, middle, ring, pinky;
double sensorArray[5] = {};

```

```

const int receive_pin = 11;
int thumb_init = 2000;
int index_init = 1500;
int middle_init = 1500;
int ring_init = 1500;

```

```

int pinky_init = 1500;

void setup() {

    pinkyServ.attach(6);
    ringServ.attach(5);
    middleServ.attach(4);
    indexServ.attach(3);
    thumbServ.attach(2);

    thumbServ.write(thumb_init);
    indexServ.write(index_init);
    middleServ.write(middle_init);
    ringServ.write(ring_init);
    pinkyServ.write(pinky_init);
    vw_set_rx_pin(receive_pin);

    Serial.begin(9600);
    vw_set_ptt_inverted(true);
    vw_setup(2000);
    vw_rx_start();

}

void loop() {
    uint8_t buf[VW_MAX_MESSAGE_LEN];
    uint8_t buflen = VW_MAX_MESSAGE_LEN;

    // Non-blocking
    if (vw_get_message(buf, &buflen))
    {
        memcpy(sensorArray, buf, buflen);
        //int i;
        // Turn on a light to show received good message
        digitalWrite(12, true);

        // Message with a good checksum received, dump it.
        //for (i = 0; i < buflen; i++)
        //{
            // Fill Sensor1CharMsg Char array with corresponding

```

```

// chars from buffer.
//sensorArray[i] = char(buf[i]);

//}
thumb= sensorArray[0];// == x;
index= sensorArray[1]; //== y;
middle= sensorArray[2]; //== z;
ring= sensorArray[3];
pinky= sensorArray[4];
//thumb & pinky positons are inversed with other three

// thumb = 180 - thumb;
// pinky = 180 - pinky;

if (thumb<=100){thumb = 0;}
// else if (thumb>80 && thumb<=100){thumb=90;}
else {thumb=180;}
//
if (index<=100){index = 0;}
// else if (index>80 && index<=100){index=90;}
else {index=180;}
//
if (middle<=100){middle = 0;}
// else if (middle>80 && middle<=100){middle=90;}
else {middle=180;}
//
if (ring<=100){ring = 0;}
// else if (ring>80 && ring<=100){ring=90;}
else {ring=180;}

if (pinky<=100){pinky = 0;}
// else if (pinky>80 && pinky<=100){pinky=90;}
else {pinky=180;}
//data received

// edit2
// pinky += 90;
// ring += 90;
// middle += 90;
// index += 90;
// thumb += 150;

```

```

//edit1

// index = 180 - index;
// middle = 180 - middle;

//edit1end
//edit2end

// mapping for servotimer2
thumb = map(thumb,0,180,1375,2000);

index = map(index,0,180,2250,1500);
middle = map(middle,0,180,2250,1125);
ring = map(ring,0,180,750,1500);
pinky = map(pinky,0,180,750,1500);

if (thumb>thumb_init) thumbhigh();
else if(thumb<thumb_init) thumblow();

if (index>index_init) indexhigh();
else if(index<index_init) indexlow();

if (middle>middle_init) middlehigh();
else if(middle<middle_init) middlelow();

if (ring>ring_init) ringhigh();
else if(ring<ring_init) ringlow();

if (pinky>pinky_init) pinkyhigh();
else if(pinky<pinky_init) pinkylow();

// thumbServ.write(thumb);
// delay(50);
// indexServ.write(index);
// delay(50);
// middleServ.write(middle);
// delay(50);
// ringServ.write(ring);
// delay(50);
// pinkyServ.write(pinky);
// delay(50);
Serial.print("Thumb: ");

```

```

Serial.print(thumb);

Serial.print(" Index: ");
Serial.print(index);

Serial.print(" Middle: ");
Serial.print(middle);

Serial.print(" Ring: ");
Serial.print(ring);

Serial.print(" Pinky: ");
Serial.println(pinky);

Serial.print("\n_____ \n");

thumb_init = thumb;
index_init = index;
middle_init = middle;
ring_init = ring;
pinky_init = pinky;

}
//
// thumbServ.write(2250);
// indexServ.write(2250);
// middleServ.write(2250);
// ringServ.write(750);
// pinkyServ.write(2250);
}

//thumb
void thumbhigh(){
  for(int i = thumb_init; i<=thumb; i++){
    thumbServ.write(i);
    delayMicroseconds(100);
  }
}
void thumblow(){
  for(int i = thumb_init; i>=thumb; i--){
    thumbServ.write(i);
    delayMicroseconds(100);
  }
}

```

```

}
//index
void indexhigh(){
    for(int i = index_init; i<=index; i++){
        indexServ.write(i);
        delayMicroseconds(100);
    }
}
void indexlow(){
    for(int i = index_init; i>=index; i--){
        indexServ.write(i);
        delayMicroseconds(100);
    }
}
//middle
void middlehigh(){
    for(int i = middle_init; i<=middle; i++){
        middleServ.write(i);
        delayMicroseconds(100);
    }
}
void middlelow(){
    for(int i = middle_init; i>=middle; i--){
        middleServ.write(i);
        delayMicroseconds(100);
    }
}
//ring
void ringhigh(){
    for(int i = ring_init; i<=ring; i++){
        ringServ.write(i);
        delayMicroseconds(100);
    }
}
void ringlow(){
    for(int i = ring_init; i>=ring; i--){
        ringServ.write(i);
        delayMicroseconds(100);
    }
}
void pinkyhigh(){
    for(int i = pinky_init; i<=pinky; i++){
        pinkyServ.write(i);

```

```
    delayMicroseconds(100);  
  }  
}  
void pinkyLow(){  
  for(int i = pinky_init; i>=pinky; i--){  
    pinkyServ.write(i);  
    delayMicroseconds(100);  
  }  
}
```



## Assessment Guideline for Faculty

[The following assessment guideline is for faculty ONLY. This portion is not applicable for students.]

### Assessment Tools and CO Assessment Guideline

	Distribution of assessment points among various COs assessed in different semesters														
PO □	l	c	f	g	c	b	d	c	e	l	k	k	h	i	j
CO □	CO 1	CO 2	CO 3	CO 4	CO 5	CO 6	CO 7	CO 8	CO 9	CO 10	CO 11	CO 12	CO 13	CO 14	CO 15
EEE 400C/ ECE 402C (Out of 100)							30	24	6	4	4	6	7	7	12
Project Final Report/ Project Progress Report							x	x	x	x	x	x	x		x
Demonstration of working prototype							x								x
Progress Presentation/ Final Presentation								x			x				
Peer-evaluation*													x	x	
Instructor's Assessment*													x	x	
Demonstration at FYDP Showcase								x							x

Note: The star (\*) marked deliverables/skills will be evaluated at various stages of the project.

### Mapping of CO-PO-Taxonomy Domain & Level- Delivery-Assessment Tool

Sl.	CO Description	PO	Bloom's Taxonomy Domain/Level	Assessment Tools
CO7	<b>Evaluate</b> the performance of the developed solution with respect to the given specifications, requirements and standards	d	Cognitive/ Evaluate	<ul style="list-style-type: none"> <li>• Demonstration of working prototype</li> <li>• Project Progress Report on working prototype</li> </ul>
CO8	<b>Complete</b> the final design and development of the solution with necessary adjustment based on performance evaluation	c	Cognitive/ Create	<ul style="list-style-type: none"> <li>• Project Final Report</li> <li>• Final Presentation</li> <li>• Demonstration at FYDP Showcase</li> </ul>
CO9	<b>Use</b> modern engineering and IT tools to design, develop and validate the solution	e	Cognitive/ Understand, Psychomotor/ Precision	<ul style="list-style-type: none"> <li>• Project Final Report</li> </ul>
CO10	<b>Conduct</b> independent research, literature survey and learning of new technologies and concepts as appropriate to design, develop and validate the solution	l	Cognitive/ Apply	<ul style="list-style-type: none"> <li>• Project Final Report</li> </ul>
CO11**	<b>Demonstrate</b> project management skill in various stages of developing the solution of engineering design project	k	Cognitive/ Apply Affective/ Valuing	<ul style="list-style-type: none"> <li>• Project Final Report</li> <li>• Project Progress presentation at various stages</li> </ul>
CO12	<b>Perform</b> cost-benefit and economic analysis of the solution	k	Cognitive/ Apply	<ul style="list-style-type: none"> <li>• Project Final Report</li> </ul>
CO13	<b>Apply</b> ethical considerations and professional responsibilities in designing the solution and throughout the project development phases	h	Cognitive/ Apply Affective/ Valuing	<ul style="list-style-type: none"> <li>• Peer-evaluation,</li> <li>• Instructor's Assessment</li> <li>• Final Report</li> </ul>
CO14**	<b>Perform</b> effectively as an individual and as a team member for successfully completion of the project	i	Affective/ Characterization	<ul style="list-style-type: none"> <li>• Peer-evaluation</li> <li>• Instructor's Assessment</li> </ul>
CO15**	<b>Communicate</b> effectively through writings, journals, technical reports, deliverables, presentations and verbal communication as appropriate at various stages of project development	j	Cognitive/ Understand Psychomotor/ Precision Affective/ Valuing	<ul style="list-style-type: none"> <li>• Project Final Report</li> <li>• Progress Presentations,</li> <li>• Final Presentation</li> <li>• Demonstration at FYDP Showcase</li> </ul>

Note: The double star (\*\*) marked CO will be assessed at various stages of the project through indirect deliverables.