

Design of Charge Controller for Solar PV Systems

By

Abdullah Al Jawad
21121038

MD. Moazzul Islam
19121020

S M Shahriar Kabir Sijan
19121052

Rajia Jannat Liya
18121038

Laila Khairun Nahar
19121025

A Final Year Design Project (FYDP) submitted to the Department of Electrical and Electronics Engineering in partial fulfillment of the requirements for the degree of B.Sc. in Electrical and Electronics Engineering

Academic Technical Committee (ATC) Panel Member:

Dr. Abu S.M. Mohsin, PhD (Chair)
Associate Professor, Department of EEE, BRAC University

Taiyeb Hasan Sakib (Member)
Lecturer, Department of EEE, BRAC University

Ehsanul Karim (Member)
Lecturer, Department of EEE, BRAC University

Electrical and Electronics Engineering
BRAC University
April 2023

© 2023. BRAC University
All rights reserved.

Declaration

It is hereby declared that

1. The Final Year Design Project (FYDP) submitted is my/our own original work while completing degree at BRAC University.
2. The Final Year Design Project (FYDP) does not contain material previously published or written by a third party, except where this is appropriately cited through full and accurate referencing.
3. The Final Year Design Project (FYDP) does not contain material which has been accepted, or submitted, for any other degree or diploma at a university or other institution.
4. I/We have acknowledged all main sources of help.

Student's Full Name & Signature:

Abdullah Al Jawad
21121038

MD. Moazzul Islam
19121020

Rajia Jannat Liya
18121038

Laila Khairun Nahar
19121025

S M Shahriar Kabir Sijan
19121052

Approval

The Final Year Design Project (FYDP) titled “Design of Charge Controller for Solar PV Systems” submitted by

1. Abdullah Al Jawad (21121038)
2. MD. Moazzul Islam (19121020)
3. Rajia Jannat Liya (18121038)
4. Laila Khairun Nahar (19121025)
5. S M Shahriar Kabir Sijan (19121052)

of Spring, 2023, has been accepted as satisfactory in partial fulfillment of the requirement for the degree of B.Sc. in Electrical and Electronics Engineering on 27th April, 2023.

Examining Committee:

Academic Technical
Committee (ATC):
(Chair)

Dr. Abu S.M. Mohsin, PhD
Associate Professor, Department of EEE,
BRAC University

Final Year Design Project
Coordination Committee:
(Chair)

Dr. Abu S.M. Mohsin, PhD
Associate Professor, Department of EEE,
BRAC University

Department Chair:

Dr. MD.Mosaddequr Rahman, PhD
Professor and Chairperson, Department of EEE
BRAC University

Ethics Statement

Our final year design project report contains 10% plagiarism.

Abstract/ Executive Summary

The purpose of this project is to develop a low-cost, efficient solar charge controller. The system utilizes the use of Solar PV system more effectively by increasing the battery life .With a battery rated at 9A, the charge controller adjusts its output to a step of 12V. The design consists of four phases, including a power supply unit, a battery charge controller, a current booster, and a battery level indicator. The system as conceived is exceedingly practical, cost-effective, and efficient. This work is a prototype for a commercial solar charge controller that includes safety features to guard against battery damage brought on by uncontrolled charging and draining mechanisms. This proposed system of low cost more effective solar charge controller has potential to improve the efficiency of batteries.

Keywords: Low cost, Efficient, Solar charge controller, Solar PV system, Battery Lifespan.

Dedication

Special thanks to our ATC Chair Dr. Abu S. M. Mohsin sir for guiding us throughout the project.

Acknowledgement

We would like to extend our sincere appreciation to BRAC University for the invaluable support in this project. The technical support provided by BRAC University has been remarkable in the success of our project. We also would like to express our sincere gratitude to the Department of Electrical and Electronics Engineering of BRAC University for providing us with various support. Their guidance and expertise have been greatly beneficial to our team and we are deeply grateful to them for their support.

Table of Contents

Declaration	2
Approval	3
Ethics Statement	4
Abstract/ Executive Summary	5
Dedication	6
Acknowledgement	7
Table of Contents	8-11
List of Tables	12-13
List of Figures	14-15
List of Acronyms	16
Glossary	17

Chapter 1: Introduction [CO1, CO2, CO3, CO10]

1.1 Introduction.....	18
1.1.1 Problem statement.....	18
1.1.2 Background Study.....	19
1.1.3 Literature gap.....	19
1.1.4 Relevance to current and future industry.....	20
1.2 Objectives, Requirements, Specifications and Constraints.....	21
1.2.1 Objectives.....	21
1.2.2 Functional and Non-Functional Requirements.....	22
1.2.3 Specifications.....	24
1.2.4 Technical consideration and constraint and Non-technical consideration and constraint in design process	26
1.2.5 Applicable compliance, standards and codes.....	26
1.3 Summary of the Proposed Project.....	28
1.4 Conclusion.....	29

Chapter 2: Project Design Approach [CO5, CO6]

2.1 Introduction.....	30
2.2 Identify multiple design Approach.....	30
2.3 Describe multiple design Approach	30
Design-01 PWM.....	30
Design-02 MPPT.....	31
Design-03 Shunt.....	32
2.4 Analysis of multiple approaches.....	33
2.5 Conclusion.....	34

Chapter 3: Use of Modern Engineering and IT Tool [CO9]

3.1 Introduction.....	35
3.2 Select appropriate engineering and IT tools.....	35
3.3 Use of modern engineering and IT tools.....	36
3.4 Conclusion.....	38

Chapter 4: Optimization of Multiple Design and Finding the Optimal Solution [CO5, CO6, CO7]

4.1 Introduction.....	39
4.2 Optimization of multiple design approach.....	39
Design-01 PWM.....	39
Design-02 MPPT.....	41
Design-03 Shunt.....	44
4.3 Identify optimal design approach.....	45
4.4 Performance evaluation of developed solution.....	46
4.5 Conclusion.....	47

Chapter 5: Completion of Final Design and Validation. [CO8]

5.1 Introduction.....	48
5.2 Completion of final design.....	48
5.2.1 Design Methodology and Design Process.....	48
5.2.2 Data Collection and Analysis.....	50
5.3 Evaluate the solution to meet the desired need.....	53
5.4 Conclusion.....	57

Chapter 6: Impact Analysis and Project Sustainability. [CO3, CO4]

6.1 Introduction.....	58
6.2 Assess the impact of the solution.....	58
6.3 Evaluate the sustainability.....	59
6.3.1 Maintainability and Manufacturability.....	59
6.3.2 Sustainability.....	60
6.4 Conclusion.....	62

Chapter 7: Engineering Project Management [CO11, CO14]

7.1 Introduction.....	63
7.2 Define, plan and manage engineering project.....	63
7.3 Evaluate project progress.....	66
7.4 Conclusion.....	68

Chapter 8: Economical Analysis [CO12]

8.1 Introduction.....	69
8.2 Economic analysis.....	69
8.3 Cost-benefit analysis.....	70
8.4 Evaluate economic and financial aspects.....	74
8.5 Conclusion.....	75

Chapter 9: Ethics and Professional Responsibilities CO13, CO2

9.1 Introduction.....	76
9.2 Identify ethical issues and professional responsibility.....	76
9.3 Apply ethical issues and professional responsibility.....	77
Legal Consent.....	77
Risk Management and Contingency Plan.....	77
Safety Consideration.....	80
9.4 Conclusion.....	81

Chapter 10: Conclusion and Future Work.

10.1 Project summary/Conclusion.....	82
10.2 Future work.....	82

Chapter 11: Identification of Complex Engineering Problems and Activities

11.1: Identify the attribute of complex engineering problem (EP).....	83
11.2: Provide reasoning how the project address selected attribute (EP).....	84
11.3 Identify the attribute of complex engineering activities (EA).....	85
11.4 Provide reasoning how the project address selected attribute (EA).....	86

References.....	88
-----------------	----

Appendix.....	91
---------------	----

List of tables:

Table 1:Total load calculation of the flat	22
Table 2:Load calculation	23
Table 3: Specification: System & Component level	24
Table 4:Applicable compliance, standards, and codes	27
Table 5:Comparison Table	33
Table 6: Parameter value of PWM	41
Table 7:Parameter value of MPPT	44
Table 8: Optimal design approach	45
Table 9:Weighted Decision Matrix	46
Table 10:Project Object	55
Table 11: Evaluate the model results with the desired needs	56
Table 12: Data Table	56
Table 13: Weighted Decision Matrix for technology analysis	61
Table 14: Project plan evaluation	67
Table 15: Budget Prototype	70

Table 16: Cost analysis (Prototype)	71
Table 17: Market analysis	73
Table 18: Risk management Analysis	77
Table 19: Attributes of complex engineering problems(EP)	84
Table 20: Attributes of complex engineering Activities(EA)	86
Table 21: Team logbook 400P	91
Table 22: Team logbook 400D	93
Table 23: Team logbook 400C	95

List of Figure:

Fig 1: PWM charge controller	30
Fig 2: MPPT charge controller	31
Fig 3: Shunt Charge controller	32
Fig 4: PWM Charge controller simulation	39
Fig 5: Result on display (PWM)	40
Fig 6: Graph for SOC	40
Fig 7: MPPT Charge controller simulation	41
Fig 8: Result on display	42
Fig 9: Output wave shapes of PV power, MPPT gain and duty cycle	43
Fig 10: Graphs for output voltage, current and SOC	43
Fig 11: Shunt Charge controller simulation	44
Fig 12: Hardware setup	49

Fig 13: Hardware circuit and pcb design	50
Fig 14: Bulk charging mode	51
Fig 15: Float charging mode	51
Fig 16: Auto charging cutoff	52
Fig 17: Load auto cutoff	52
Fig 18: Project plan EEE-400P	63
Fig 19: Project plan EEE-400D	64
Fig 20: Project plan EEE-400C	64
Fig 21: Work Duration of EEE400P	65
Fig 22: Work Duration of EEE400D	65
Fig 23: Work Duration of EEE400C	66
Fig 24: Legal Consent Form	97
Fig 25: Flat Owner Consent Form	98

List of Acronyms

IEEE-	Institute of Electrical and Electronics Engineers
IoT-	Internet of Things
USB-	Universal Serial Bus
PCB-	Printed Circuit Board
LCD-	Liquid Crystal Display
LED-	Light Emitting Diode

Glossary

Sensor	a device that detects changes in a physical quantity and converts it into a signal that can be read by an instrument or device.
C programming	C is a general-purpose, procedural programming language closer to machine language and provides more control over the computer's hardware.
Data set	a collection of data, often in tabular form, that is organized for a specific purpose or use.
IoT	The term "Internet of Things" refers to the network of physical devices, vehicles, structures, and other items embedded with electronics, software, sensors, and connectivity that enables these objects to communicate and interchange data with one another, the internet, and other devices.

Chapter 1: Introduction- [CO1, CO2, CO10]

Introduction

1.1 Introduction

A solar charge controller helps us by regulating the amount of electrical charge that is transferred from solar panels to batteries. This helps to guarantee that the batteries are charged at the correct pace and voltage, which in turn contributes to the elongation of the batteries' lifespan. When exposed, solar panels produce electricity and sunlight, but the amount of electricity produced varies based on the quantity of light. This means that the voltage and current levels can fluctuate, and if left unregulated, can damage the batteries. A solar charge controller acts as a middleman between the solar panels and the batteries. It keeps track of the voltage and current that are being produced by the panels and makes any necessary adjustments so that they are compatible with the batteries. This protects the batteries from being overcharged and undercharged, which can significantly reduce their lifespan.

1.1.1 Problem Statement

Among the most significant sources of clean energy that has seen increasing interest in recent years is solar energy. Nowadays we face an electricity crisis because resources from nature like fuel, diesel, petroleum, and others are becoming more and more expensive, exceeding the means of the average person. Furthermore, the best option is solar energy because it poses no pollution or health risks at all. A charge controller, sometimes called a charge regulator, is a current and voltage regulator used to prevent batteries from being overcharged. It regulates the solar-generated voltage and current entering the battery. Since most 12-volt panels generate between 16 and 20 volts, batteries will be damaged by overcharging if there is no limit.[3] The photovoltaic cells must supply some extra electricity so that we may continue to use them even when sunlight is scarce, there is a lot of haze, there is a cloud cover, or it is very hot outside. When a battery is fully charged, the effect of uncontrolled charging will be an exceptionally high battery voltage. This can speed up grid degradation, loss of electrolytes, severe gassing, and internal heating. As a result, the charge controller keeps the battery in good condition and increases its lifespan. Bangladesh, a tropical region in the world where there is plenty of sunlight to meet the demand for power production. As our country is not blessed with enough natural resources, it is an essential product for using electricity in the future. According to Fortune business insights, the global market for solar charge controllers, which was valued at USD 1.12 billion by 2018, is anticipated to grow to USD 3.59 billion in 2026, at a CAGR of 15.8% from 2019 to 2026. [4]

Also, Southeast Asia, the biggest local markets of solar charge controllers will continue to exist. In addition to this, the use of this procedure is becoming more widespread in the countries of Africa and Latin America. The increasing need for renewable energy sources is driving

growth in the market for solar charge controllers consider the solar industry. Both the battery systems and the power supply system's safety are maintained in large part by the charge controller.

1.1.2 Background Study

Solar energy has emerged as one of the most major sources of renewable energy in recent years, which has contributed to the increased attention it has received. Due to growing gas prices and the increased demand for renewable resources like fuel, petroleum, and diesel, we are currently experiencing an electricity crisis. Solar energy is also the best option because it poses no pollution or health risks at all. Overcharging of batteries may be avoided with the use of a current and voltage regulator, which is sometimes referred to as a charge controller or charge regulator. It regulates the amount of current and voltage that flows from the batteries as well as the solar panels. In the absence of regulation, the vast majority of 12-volt panels have an output ranging from 16 to 20 volts, which will lead to the overcharging and subsequent degradation of the batteries.[3] So that we can still get a certain amount of energy from the solar panel when the sun is low in the horizon, or when there is a lot of fog, cloud cover, or heat, the solar panels need to supply a little extra voltage. When completely charged, batteries with unmonitored chargers may reach dangerously high voltages that accelerate grid corrosion, electrolyte loss, excessive gassing, and internal heating. As a result, the charge controller keeps the battery in good condition and increases its lifespan. Bangladesh is always a tropical nation where there is plenty of sunlight to meet the demand for power production. Given the lack of sufficient natural resources in our country, it will be crucial to use this product in the future in order to use electricity. According to Fortune's analysis, the worldwide market for solar charge controllers was worth USD 1.12 billion in 2018, and it is expected to expand to USD 3.59 billion in 2026, at a compound annual growth rate (CAGR) of 15.8% between 2019 and 2026. [4]

Additionally, the greatest worldwide market for solar power controllers will continue to be Southeast Asia. Additionally, this practice has been gaining popularity in Latin American and African nations. The market for solar charge controllers is being pushed by the rising popularity of renewable energy sources. Both the battery systems and the power supply system's safety are maintained in large part by the charge controller.

1.1.3 Literature Gap

In Bangladesh, most of the work done on energy-saving issues is in the theoretical method. So, all the research and inventions never reached the people who use them. So still many people mostly in rural areas are facing the issue. Also, as this process is very costly many cannot afford it. Therefore, we must provide people with a system that is more efficient at a low cost.[3] However, one of the major challenges is introducing people and making them more familiar with this system. For the application of this system large space is needed. Still today many hilly regions are deprived of power connection at a reasonable rate.[1] Also, many rural areas do not get a proper power supply. These problems need to be mitigated. And to solve these problems, the best way is to use more and more renewable energy. Due to non-linear solar PV

characteristics and atmospheric conditions, solar PV efficiency is significantly decreased. The photovoltaic PV system's maximum output as a result varies according to the amount of irradiance and the weather. It is also necessary to have a battery charger that is equipped with a charge controller in order to make the most of the amount of power that is transferred from a solar PV system to a battery bank. The major function of a battery charger that also includes a charge controller is 1.) The operating system is set at MPP regardless of changes in irradiation, which aids in tracking maximum power. 2.) It shortens the time needed to charge batteries to support PV arrays. There are many types of charge controller available in the market. But most of them are not efficient enough. Even if some are efficient, they are very costly. There are a great number of individuals who are unable to buy it and are not knowledgeable about charge controllers. However, the solar charge controller is an extremely vital component of a solar photovoltaic (PV) cell. And here is where we discover the problem. So, to have an efficient charge controller for less price is so important.

1.1.4 Relevance to the current and future industries

Firstly, our plan is to enhancing a solar charge controller's effectiveness through our selective and efficient designs with a minimum cost. After successfully implementing our plans, we want to extend the field where the importance of solar controller will be hold an emergent place to make power from the solar energy Also, we want to make our setup for improving the capability of the battery life and other equipment's with a very low cost and without any fault in future. However, our main aim to use our designed project into the rural areas and most of the places where there is still lacking of enough electricity. Mostly, our target is for our farmers and for irrigation system. Our country is a agriculture based country and during the season of irrigation, our farmers face unbearable problems due to severe load shedding and lacking of enough electricity. Here our project can be more beneficial to produce enough electricity for irrigation and to reduce the sufferings of the farmers. Also, we want to enhance the importance of this project in our garments sector and other industries. These industries require a lot of power to produce their respective products but in our country 64% of the total generation of electricity comes from naturally produced gas and nowadays of the fuels is increasing at a hazardous rate. This is why there are happening load shedding all over the country and these industries are being forced to shut down their industries for a couple of hours. To overcome this situation, our project holds a significant place to produce and supply required power efficiently. Furthermore, modern solar charge controllers are designed with sustainability in mind, incorporating advanced electronics and energy-saving features to further reduce energy waste and improve overall system efficiency. Also, this system can be used in our school, college, recreation centers and other places with a very low cost and that will help our people economically. Indeed, creating such a system with more advanced performance of the controller in producing solar energy is well suited to our time.

1.2 Objectives, Requirements, Specification and constant

1.2.1. Objectives

➤ **To design an affordable and effective solar charging controller:**

Charge controllers for solar panels may be purchased in a wide variety of flavors on the market today. But most of them are expensive with lower efficiency. Again, there are some controllers which are efficient enough but everyone cannot afford them. As a result, people specially, who live in remote areas are not getting enough electricity. Charge controllers for solar panels may be purchased in a wide variety of flavors on the market today. We have utilized such efficient solar charge controllers in our design in order to get maximum power. These controllers will decrease the greater voltage that is produced by the DC output of a solar panel to the lower voltage that is necessary to charge batteries. The charge controller is going to do a comparison between the voltage of the battery and the outputs of the panels. The solar panel's ability to provide the most efficient amount of energy for the purpose of charging the battery will subsequently be evaluated. After that, it will take this information and translate it to the optimal voltage in order to extract the maximum power out of the battery. In comparison to existing solar charge controllers on the market, this system will increase controller efficiency at a cost of less than 22%.

➤ **Tracking maximum power:**

This design can fulfill the demand of tracking maximum power. During the winter season, we cannot get enough solar power to recharge the batteries where our desired controllers work better in the cold weather and can track 20 to 45% power than other controllers. Again, this system is suitable for both low and high voltage battery state. More current is injected into batteries at lower levels of charge, which is another situation where the additional energy is most needed. Both of these circumstances may exist simultaneously. These features all meet the requirement for tracking maximum power.

➤ **Prevent overcharging:**

Because of this configuration, we are able to exercise control over the output voltage of the solar panel, which stops the batteries from being overcharged. Here we have put a limit for a 12-volt battery which is 13 volts maximum and 10 volts minimum when the voltage level comes to 12. 5-volt Charging will be automatically cut off and when the voltage level goes down to 10 volt the system load will be cut off immediately. This is how this system will prevent the batteries from both overcharging and undercharging.

➤ **Extending battery lifespan:**

This design makes use of a solar charge controller that can handle both high and low voltage battery states. The lower the level of charge of the battery, the greater the amount of current that is supplied to it. Once again, when the voltage exceeds the maximum range, the system that is responsible for charging will be quickly shut off, and when the voltage hits the lowest range, the load will be turned off as soon as

possible. Because of these properties, the battery has a long lifespan and is not threatened or challenged in any way.

➤ **Reduces the time it takes for batteries to recharge to support PV arrays:**

This charge controller was created with the goal of cutting down battery charging time. It can charge many batteries simultaneously and obtain the required current via the PV panel.

1.2.2 Functional and Nonfunctional Requirements

Setup area:

We are designing this project for a flat of 1460 sq feet in a building at Khilgaon. This flat consists of three rooms, two washrooms, one kitchen, and a dining room. Approximately 5-10% are low loads and 90-95% are heavy loads, approximately 4% are low loads of this flat. That means we will make this project for the low loads such as fans, bulbs, etc.

General requirements:

We will design a 12V charge controller to enhance the battery's ability to govern charging and discharging.

Table:1 Total Load Calculation of the flat

Load Name	Amount	Load Rating (watt)	Sub Total Load (Watt)
LED Bulb	10	20	200
Fan	4	75	300
AC (1 Ton)	2	3500	7000
Refrigerator	2	750	1500
Geysers	1	1000	1000
		Total	10000

We will control the low loads of these loads mentioned above.

Load Calculations that we will control:

Table: 2 Load Calculations

Load Name	Amount	Load Rating (watt)	Sub Total Load (Watt)
LED Bulb	6	20	120
Fan	3	75	225
		Total	=345

System Level requirements:

- Voltage level detector.
- Microcontroller for capturing the maximum Solar Energy and inverting Voltage from DC to AC.

Component Level requirements:

- Photovoltaic cell
- Microcontroller
- Battery
- Inverter
- Voltage Sensor
- Wi-Fi Module
- Temperature Sensor
- Current Sensor
- Liquid Crystal Display
- Buck-Boost Converter.

1.2.3 Specifications

Table:3 Specification: System & Component level

	System Level	Component level
Functional	<p>Input unit</p> <p>→ To converts solar energy into useful electricity</p>	<p>Photovoltaic cell</p> <ul style="list-style-type: none"> • Working voltage: 12V • Output power: 100W • Working current: 0-200 A
Functional	<p>Controlling unit</p> <p>→ Maintaining the process of output variables and using sensor feedback to detect any departure from a sick point will cause the output to be automatically adjusted until the parameters are once again within acceptable limits.</p>	<ul style="list-style-type: none"> • Microcontroller (Pic18F452) Microcontroller. It is a 40-pin integrated circuit IC that is programmed in C using the micro/c programming tool. It is connected to a solar energy system, battery, load the controller, and an LCD screen and is powered by 5V dc.) • Diode
Functional	<p>Storage Unit</p> <p>→ charged with electricity produced from renewable sources, such as solar power, and coordinates energy using software Using production and computer control systems, determine whether to discharge or conserve energy for the load.</p>	<ul style="list-style-type: none"> • Battery (12 Volt)

<p style="text-align: center;">Functional</p>	<p>Initial Sensor Unit</p> <p>→ Evaluate the DC or AC voltages by responding to specific kinds of electric or optical impulses, detect the load and the solar panel flow to calculate power, and maintain a fixed output voltage regardless of modifications to the load voltage or the input voltage.</p>	<ul style="list-style-type: none"> ● Current sensor (ACS 712-20A) ● Voltage Sensor ● Voltage regulator
	<p>Converting Unit</p> <p>→ To convert the voltage from DC TO AC</p>	<ul style="list-style-type: none"> ● Inverter (12 V DC to 220 V AC)
<p style="text-align: center;">Functional</p>	<p>Hardware System</p> <p>→ The inbuilt processing and storage power of this module is sufficient for integration with sensor as well as application-specific devices via its GPIOs with little initial development required</p>	<ul style="list-style-type: none"> ● Wi-Fi-Module (ESP8266 ESP)
<p style="text-align: center;">Non functional</p>	<p>Output Unit</p> <p>→ To display the output.</p>	<ul style="list-style-type: none"> ● Liquid Crystal Display

<p style="text-align: center;">Non functional</p>	<p>Sensor unit</p> <p>→ To sense the room and battery temperature and weather conditions to continue its working process without any obstacles.</p>	<ul style="list-style-type: none"> ● LM 35 temperature sensor ● Weather detection Sensor
--	--	--

1.2.4 Technical consideration and constraint and Non-technical consideration and constraint in design process

- **Excessive Power Supply:** In case of overcharging of the battery, there can be an excessive power supply. This may result in overload. We need to design the charge controller the way it can handle this situation.
- **Huge space required:** To use a charge controller we will need a whole setup of the solar system. And this will require a huge space. So we need a large space with proper availability of sunlight.[5]
- **Designing the system at a low cost:** At present, there are many charge controllers with good efficiency available in the market. But these are very expensive and so not easily accessible to everyone. We are trying to solve this problem by designing our controller at a low cost.[7]
- **Bad Weather Condition:** The weather has a significant impact on our charge controller, which is responsible for charging the battery in a solar PV system. We are aware that sunlight is completely dependent on the solar PV system. In case of excessive rain or cloudy weather, the solar cell will not get the required amount of energy from the sun.

1.2.5 Applicable compliance, standards, and codes

To conduct this project, we need to follow some international codes and standards. There are few standards in Table3 that we should obey to design our project.

Table: 04 Applicable Standards and Codes

Device /Technology	Standard Code	Standard Name	Standard Details
Photovoltaic generator charging of a battery	IEC 62509	International Electro-technical Commission Standard	The major objectives are to enhance battery life and ensure BCC dependability. IEC 62093 and this standard must be utilized together.
Microcontrollers	IEEE 1118.1-1990	Microcontroller System Serial Controlling Bus IEEE Standard	An explanation of a serial network bus used to link microcontrollers together both within and between devices is given. The bus provides a multidrop bit-serial transfer of data that is intended for (but not limited to) sensors and microcontrollers with limited programs to enable the connecting of distributed independent studio devices.
Wi-Fi	IEEE 802.11n	Institute of Electrical and Electronics Engineers	802.11n makes use of the frequency bands with a range of 2.4 GHz and 5 GHz; nevertheless, each band operates independently. Wi-Fi 4 is the name that the Wi-Fi Alliance has given to the standard that was formerly known as 802.11n. Elements equipped with multiple input antennas were supported under the MIMO standard. 802.11n makes use of both the 2.4 GHz spectrum and the 5 GHz band simultaneously. It is not necessary to use the 5 GHz spectrum. The overall data rate is variable and may be anywhere from 54 to 600 Mbit/s.

Battery	IEEE 1625-2004	IEEE Standard for Rechargeable Batteries for Portable Computing	According to the criteria presented in this standard, rechargeable batteries for portable computing devices meet the requirements of being certified, of high quality, and dependable. Additionally, it offers techniques for measuring the operational effectiveness of these types of batteries and the related oversight and oversight systems, taking end-user notification into account.
Sensor for AC Current and Voltage	IEEE 1601-2010	Optical AC Current and Voltage Sensing Systems: IEEE Trial-Use Standard	This trial-use standard provides information to help with the right equipment selection for electricity. These standard addresses specific physical traits of sensor systems that monitor current and voltage using optical methods. This standard outlines the specifications for the characteristics of performance and testing of visual current and voltage detectors with nominal system voltages of 1 kV and higher, as well as information regarding the characteristics of these sensors and their intended uses.
Temperature Sensor	IEEE2700-2014	Sensor Efficiency Parameter Definition according to IEEE Standard	Sensor performance requirements are provided inside a standardized framework that defines common terms, units, conditions, and bounds. Sensors such as gyroscopes, pressure gauges, thermometers, light detectors, and proximity detectors are discussed in detail.

1.3 Systematic Overview/summary of the proposed project

Our design goal is to build a charge controller within a low cost and more effective way. Solar charge is the most renewable energy source available for all. If we use this solar energy more effectively the use of non-renewable energy will become less. Non-renewable energy is also not pure and harmful for our health. To use solar energy effectively first the battery life should be good. As the energy is stored in the battery the battery health is not good; it may affect the solar PV cells. And to increase the battery life span more effectively our system is proposed.

Every design has benefits and drawbacks. Out of all of them, we have to choose the one that will give us our desired result most effectively. We chose three design methods primarily for our project before setting the MPPT solar charge controller our best choice.

1.4 Conclusion

In conclusion, solar charge controllers play a critical role in the efficient and sustainable use of solar energy. They control the flow of electricity from solar panels to batteries, ensuring that the latter are charged at the correct pace and voltage to maximize their useful life. The performance and long-term viability of solar charging controllers are always being researched and developed as solar energy technology advances. Future work in this area may focus on developing more sophisticated algorithms for regulating the charging process, as well as incorporating new materials and manufacturing processes to further reduce the environmental impact of these devices. Overall, the use of a solar charge controller is essential for the efficient and sustainable use of solar power, and ongoing research and development in this area will continue to improve the performance and environmental impact of these critical devices.

Chapter 2: Project Design Approach [CO5, CO6]

2.1 Introduction

An efficient charge controller can prevent a battery from overcharging and undercharging. A solar charge controller helps us by regulating the amount of charge that is transferred from solar panel to battery. It ensures that the batteries are charged at the appropriate rate and voltage, which helps to extend the life of the batteries. Solar panels generate electricity when exposed to sunlight, but the amount of electricity produced varies and current levels can fluctuate and if left unregulated can damage the battery. The intensity of sunlight is different in different places. So, a charge controller should be able to cope up with high sunlight even with low sunlight. There are so many designs for a charge controller but all do not meet our desired expectation. We wanted to design an efficient charge controller at a low cost. So, after research we found three designs suitable to conduct our experiments.

2.2 Identify multiple design approach

After some research and analysis, we have chosen 3 design approaches.

1. Pulse width Modulation Solar Charge controller
2. Maximum Power Point Tracker Charge controller
3. Shunt Charge Controller.

2.3 Describe multiple design approach

Design 1:

Pulse Width Modulation Charge Controller (PWM)

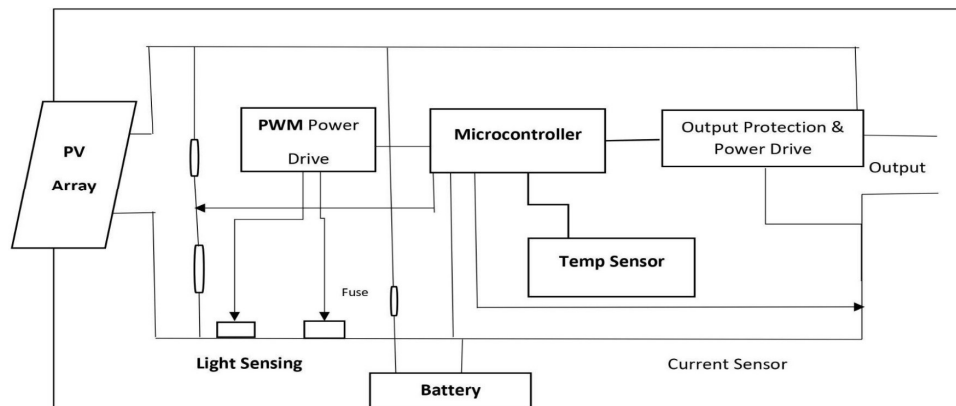

Fig: 01 Pulse Width Modulation Charge Controller

With the use of pulse width modulation technology, it is possible to charge batteries in multiple stages, including bulk, absorb, and float, which greatly enhances charging control and efficiency while also extending battery life. They are still employed in distant and industrial situations where having tiny, straightforward, and very robust equipment is essential. Many variants have been ruggedized for use in industrial settings. The most efficient method for charging batteries at a constant voltage is to make use of a pulse width modulation (PWM) charge controller and to adjust the duty ratios of the switches that employ metal oxide semiconductor field effect transistors. The amount of current drawn from the PWM charge controller by the solar panel is directly proportional to the status of the battery and how much it needs to be recharged. The PWM algorithm gradually decreases charging when a battery voltage exceeds the specified threshold for control. This prevents the current battery from overheating and gassing while charging still continues to restore the greatest amount of energy to the battery in the shortest period of time. It is planned to get the voltage of the array down to a level that is comparable to that of the batteries. PWM controllers are not the same thing as DC-to-DC transformers. The PWM controller may be thought of as a switch that connects the battery and the solar panel.

Design 2:

MPPT (Maximum Power Point Tracker) Charge Controller

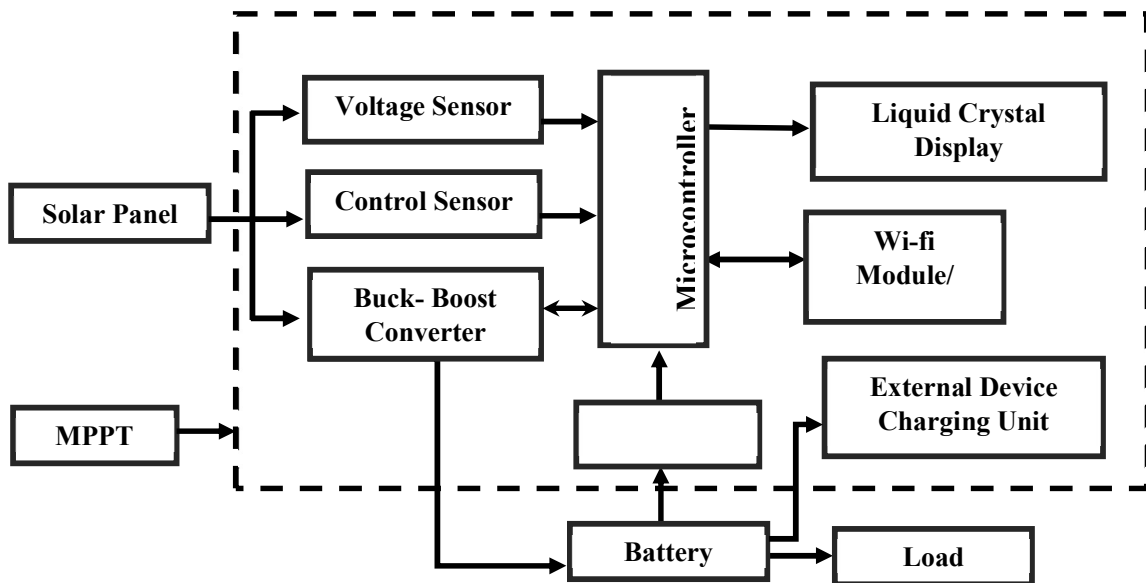

Fig: 02 MPPT Charge Controller

Battery performance depends on specific charging requirements. Unique electrical properties of solar modules fluctuate throughout the day. If we want the solar array to charge the battery

as efficiently as possible, we need a technology that can translate or convert the solar energy so that it can be used by the battery. An MPPT controller, short for "highest Power location Tracking," ensures that the solar array is always being used in its most productive orientation. It's more difficult and expensive. Compared to a PWM charging controller, it has several benefits. When it's cool, it's up to 40% more efficient. The heart of the maximum power point tracker is a synchronous buck converter. It converts the greater voltage from the solar panels to the lower voltage required by the batteries. It regulates the voltage it receives from the solar panel so that as much energy as possible may be extracted. This energy is then transformed to meet the varying voltage needs of the battery and the load. In cold climates, MPPT is preferred over PWM, however both controllers perform similarly in subtropical and tropical climates. The maximum power point tracking charge controller is a power transformer.

If the output voltage is lower than the input voltage, the output current will be larger than the input current, and the product $P=VI$ will stay constant as the amount of power is unaffected. The Maximum Power Point (MPP) is the current-voltage point on the current-voltage curve where the power output of a solar panel is maximized. An MPPT allows for this to be achieved. In principle, a PWM controller's input voltage should match that of the battery it is controlling. For this reason, the 9 solar panel is seldom utilized at its Maximum PowerPoint.

Design 3:

Shunt Charge Controller

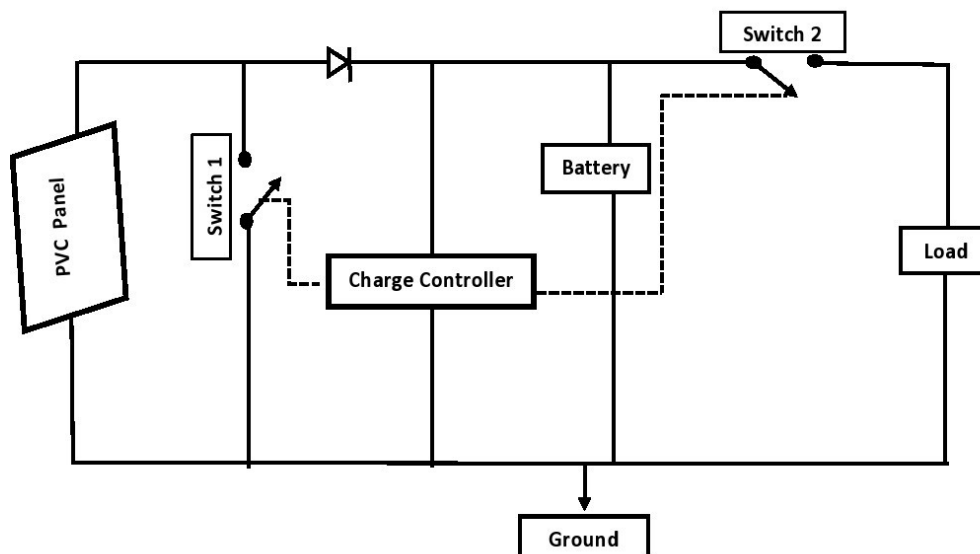

Fig: 03 Shunt Charge Controller

A shunt controller is nothing more than a simple ON/OFF switch. When the battery's voltage drops too low, the switch turns on, allowing power to flow from the solar array to the battery. When the battery voltage is at full capacity, the switch will turn OFF, ending the charging procedure. Shunts, the most basic controller type, are also the most primitive and inefficient in charging batteries. Shunting together switching components is a common method for connecting a battery to a load. Shunt charge controllers are functionally equivalent to standard controllers, with the difference that they connect the switching element in parallel and the charge controller in series. The suggested shunt charge controller requires switching signals in order to work. The results from the controller's switching function. A programmed that automatically activates switches based on the battery's charge level has also been developed. When the battery life hits 80%, the switches S1 and S2 will activate sequentially. The outcome is a simultaneous on/off behavior while both the load and the charging are active. When neither switch is engaged, charging begins immediately and continues until full. When the battery is completely charged, it begins discharging in sync with the switching signals from the controller. The major negative of a shunt charge controller is the higher power loss on the panel side that occurs when a PV module experiences a hot stop. The shunt charge controller is mostly used for low power applications.

2.4 Analysis of multiple design approach

Table: 5 Comparison Table

Basis	PWM	MPPT	Shunt
Efficiency	medium [3]	higher	less
System capacity	Lower	150W-200W Or Higher	Less than PWM
Expense	Less	Higher	Less than PWM
Complexity	Less	Higher	Flexible
Voltage Input	Lower [7]	Higher	Neutral
Battery Life	Medium	Higher	Low
Performance in between Temperature	Suitable for warm temperature	Suitable for Cold temperature	Suitable for warm temperature

2.5 Conclusion

Out of all the designs, Maximum Power Point Tracker stands out to be the best choice since it is more efficient than other designs. This one also uses Wi-Fi Module which makes it exceptional from other designs. In this design buck boost converter is also used which gives more accurate results. While considering cost we also found MPPT Charge controllers are cheaper than others. This charge controller is very easy to use for general people and is less hazardous.

Chapter 3: Use of Modern Engineering and IT Tool. [CO9]

3.1 Introduction

Innovation may be a portion of cutting-edge engineering but it is additionally centered on the headway and comprehension of innovative frameworks, their items, impacts, and suitability. Additionally, non-technological strategies are a concern. We have utilized different cutting-edge engineering apparatuses for this venture. Usually fulfilled by beginning with making an effort to memorize how the instrument is utilized, utilizing it to comprehend topics in suitable courses, and after that applying it to develop, plan, actualize, and illustrate a person's work. This has permitted us to urge proper information, and comes about for the examination of the information collected. We have legitimately explained each of the instruments to this extent.

3.2 Select appropriate engineering and IT tools

While choosing contemporary engineering tools we had two requirements to meet ; one is software tools and another is hardware tools. Initially we started designing our project on Proteus. We designed our PWM system in Proteus but did not get the expected outcome. Later we chose MATLAB Simulink because this performs best in Numerical Computation. So our final Hardware and Software tools are :

1. Hardware Tools:

- Photovoltaic cells
- Microcontroller (Pic18F452)
- Diode (1n4007) (1n5408)
- Battery
- ACS712 Current Sensor
- Voltage Sensor
- Voltage Regulator
- Wi-Fi Module (ESP8266 ESP)
- Liquid Crystal Display

2. Software Tools:

- Adobe Illustrator

3. Simulation Tools

- MATLAB Simulink
- Proteus 8 Professional

3.3 Use of modern engineering and IT tools

Hardware:

Photovoltaic cell: A photovoltaic (PV) cell is a form of energy harvesting that uses the photovoltaic effect to transform solar energy into usable power. Sunlight for photovoltaic (PV) cells may be found in a wide range of sizes and configurations, but they all have the same reliance on semiconductors to convert sun photons into an electric current. There is no one set way or material for creating a photovoltaic cell. Commercial solar cells typically employ silicon (Si), although alternative materials including gallium arsenide (GaAs), cadmium telluride (CdTe), and copper indium gallium selenide are also viable possibilities. In this case, a PV cell with a 100-watt output voltage of 12 volts will be used. An operating current of 0-200A is expected.

Microcontroller (Pic18F452): It is a 40-pin integrated circuit IC that is programmable in the C programming language using the Micro/C software. A solar panel, battery, load controller, and LCD display are connected to it, and it is powered by 5V dc. It'll make advantage of a charge controller's CPU. Microcontrollers make it possible to digitally control an ever-increasing number of objects and processes. This is made possible by the fact that microcontrollers are more compact and less costly than systems that need separate microprocessors, memory, and input/output devices. Microcontrollers that can process mixed signals are increasingly being used for the control of non-digital electrical equipment.

Diode(1n4007)/(1n5408): Diodes are semiconductor devices used to redirect current in a single direction. Simple flow is permitted in one direction, while current flow is substantially restricted in the other. Since they can convert alternating current (ac) to direct current (dc) using pulses, diodes are often referred to as rectifiers. Type, voltage, and current capacity are the three main factors used to classify diodes. The anode (positive lead) and cathode (negative lead) are what give a diode its polarity. The anode of a typical diode only allows current to flow when it is subjected to a positive voltage.

Battery: We will use the nominal voltage of the MaxGreen MG12-9 12V 9A UPS Battery is 12 V. It has a 9Ah for 20HR (10.5V), 8.4Ah for 10HR (10.5V), and 5.8Ah for 1HR capacity. High-performance plates and electrolytes are included in this UPS battery to provide more power output than a typical power backup system. Mechanized assembly and Heavy-Duty Grid are features of this UPS battery. It can give a high level of reliability and stability and has a non-spillable construction. AGM separator of superior quality is present, extending cycle life and preventing micro short circuits. The battery container's strength is increased with the aid of ABS material. Low self-discharge rates are ensured by high-purity raw materials. Six months' worth of warranty is included with the MaxGreen MG12-9 12V 9A UPS Battery.

ACS712 Current Sensor: Voltage drops along a wire when current flows through it. Ohm's law describes the relationship between voltage and current. Damage to electrical devices may

result from an increase in current beyond what is required. Correct equipment operation calls for current measurement. It is possible to detect voltage in a system without actively affecting it in any way. instead of the invasive and invisible duty of checking voltage.

Voltage sensor: Voltage sensors are small, wireless devices that may be fastened to a broad variety of structures, machines, and equipment. They keep an eye out for any abnormalities in the voltage readings at all times. Too much voltage might cause damage to other equipment, while too little could signal a problem. Alerts are immediately delivered to a central server when certain conditions are exceeded.

Voltage Regulator: Voltage regulator diodes take use of the reversing properties of a PN junction. It is possible to increase the reverse voltage of pn junction diodes until a steady current flow. We refer to both this occurrence and this voltage as breakdown phenomena.

Wi-Fi Module (ESP8266 ESP): The ESP8266 Wi-Fi Module is a standalone SOC that includes a TCP/IP protocol stack, allowing any microcontroller to connect to your Wi-Fi network. The ESP8266 may host or delegate all Wi-Fi networking functionalities from another application processor. Connecting an ESP8266 module to an Arduino device is like adding a Wi-Fi Shield—the modules come pre-programmed with the necessary AT command set software.

Liquid Crystal Display: Electronically controlled and making use of polarizers and the light-modulating capabilities of liquid crystals, a liquid-crystal display (LCD) is a kind of flat-panel display or another optical device. Because they don't generate light themselves, liquid crystal displays rely on a backlight or reflector to create either color or monochrome images.

Software:

Adobe Illustrator: Adobe Inc. created and sells Adobe Illustrator, a tool for designing and editing vector drawings. A programming tool from Autodesk called Adobe Illustrator enables complete beginners to create 3D models. This CAD tool is built on the practical strong geometry (CSG) concept, which enables users to combine simpler items to create more complex models. Because of this, many people, including teachers, children, hobbyists, and architects, already find this 3D modeling tool to be user-friendly and enjoyable. The best part is that all you need to reply to it is a web association, and it's completely free. The program permits clients to form models that are congruous with 3D printing, an incredible choice for tenderfoots to the technology. We are designing our 3D model by using this tool as it is more convenient for beginners to design any 3D model [12].

Circuit simulation:

We have various software for completing the simulation part. Some of them are mentioned below.

MATLAB Simulink: We employed MATLAB-Simulink in the creation of our Simulink model. Simulink is a graphical editor with customizable block libraries and solvers for modelling and simulating dynamic systems. Because of its integration with MATLAB, models may employ MATLAB methodologies and simulation results can be exported to MATLAB for further analysis. There are numerous toolboxes included with this graphical addition to MATLAB. The toolboxes are function libraries developed in the technical computing environment of MATLAB. We used the UAV toolbox since it contains design, simulation, testing, and deployment tools as well as examples of applications for unmanned aerial vehicles (UAVs) and drones. [11]

Proteus 8 Professional: Proteus is a fully-featured development platform, from ideation to final design. Automatic PCB wiring, intelligent principal layout, hybrid circuit simulation, accurate analysis, single-chip software debugging, and co-simulation of both internal and exterior circuits are some of its advantages.[13]

To create our software designs and compare the outcomes of simulations, we have been using the proteus software. Proteus provides compatibility for a number of popular single-chip devices and universal peripheral variants. The visual effects are superb and meet our needs because its dynamic simulation is built on frames and animation.[9] In addition, this simulation program allows us to employ a variety of sensors, simplifying the simulation process.

Choice of tools:

At first, we started to design in Proteus. We did a PWM solar charge controller in Proteus. But after the simulation, we do not get the expected data that we are looking for. Because in Numerical Computation MATLAB Simulink performs the best. Also, for graphical simulation and load simulation, MATLAB Simulink is much more reliable than Proteus. So, for these reasons, we prefer MATLAB Simulink over Proteus Software.

3.4 Conclusion

We used a variety of cutting-edge architectural advances to this extent. As a result, we were able to examine the information gathered and provide precise results. All of the tools used in this project have been fully explained. Utilizing these numerous tools has improved our understanding of cutting-edge developments, counting equipment advancements, and programming.

Chapter 4: Optimization of Multiple Design and Finding the Optimal Solution. [CO7]

4.1 Introduction

The use of Solar charge has significantly increased in the past years. Many people are using solar cells to save electricity. We can see the use of Solar cell technology in industries and mainly in rural areas. Still today there is no stable electricity connection in many rural areas. So we are becoming more dependent on solar cells. And the charge generated from solar cells is mainly saved in the battery. So battery health is very important. And to expand battery life a good charge controller is needed. A charge controller saves a battery from overcharging and undercharging. When a battery is not fully charged or over charged it risks the battery condition. And ultimately results in damage to the battery and solar cell.

4.2 Optimization of multiple design approach

Design 1

Pulse Width Modulation Charge Controller (PWM)

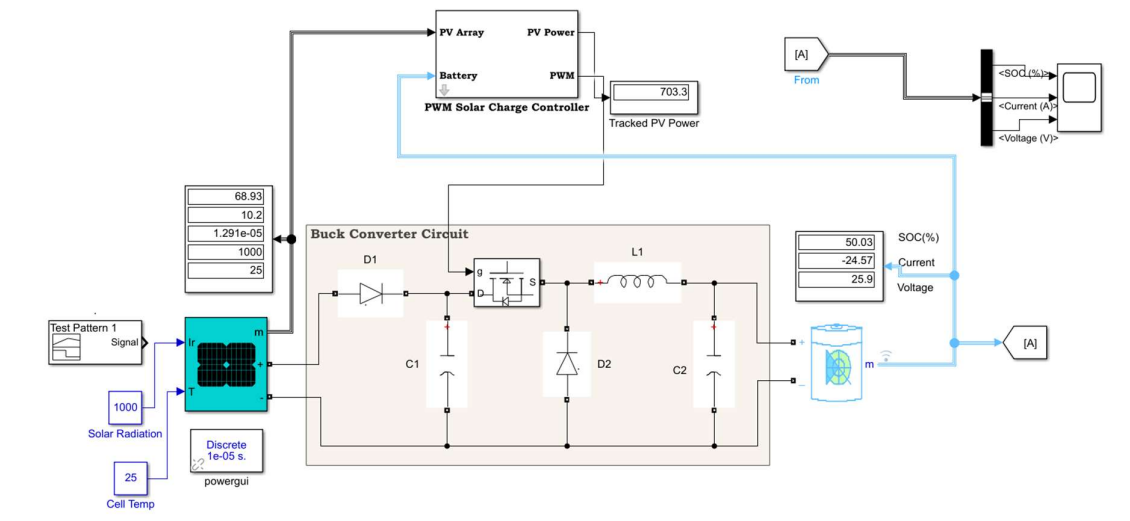

Fig:04 Pulse Width Modulation Charge Controller (PWM)

Basically, we are using MATLAB Simulink to design our simulation model. Here we are using 6 PV Array (SunPower SPR 445J WHT D). There are two parallel and four series connections between the two arrays. Cell Temperature was 25-degree Celsius and irradiation was 1000 W /m². Here we use a PWM signal with a PW array and a PV array gives a signal to the PWM

controller. Then from the PWM controller, the output goes to MOSFET. Here MOSFET works as a switch. The display connected to the Battery shows the SOC, Output current, and output voltage.

Result :

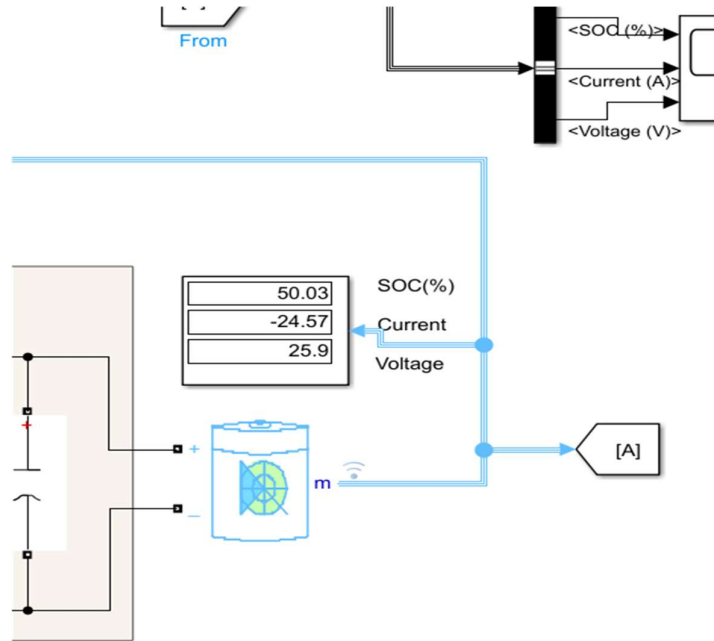

Fig:05 Result on Display (PWM)

Graph of Basic Analysis:



Fig:06 Graph for SOC (%), Current, and Voltage

Here x- axis is for Time and y axis for the measured value [SOC (%), Current, and Voltage]. Again, here at the girls graph we could see the SOC (%), at the second graph, we can see the output current and last one is for output voltage.

Basis of analysis:

Simulink run time: 10

Table:06 parameter values of PWM

Parameters	Value
SOC (%)	50.03 (Initial SOC 50%)
Output Voltage (battery)	25.9 V
Output Current (battery)	24.57 A
Power (P=VI)	636.363 W

Design 2:

MPPT (Maximum Power Point Tracker) Charge Controller

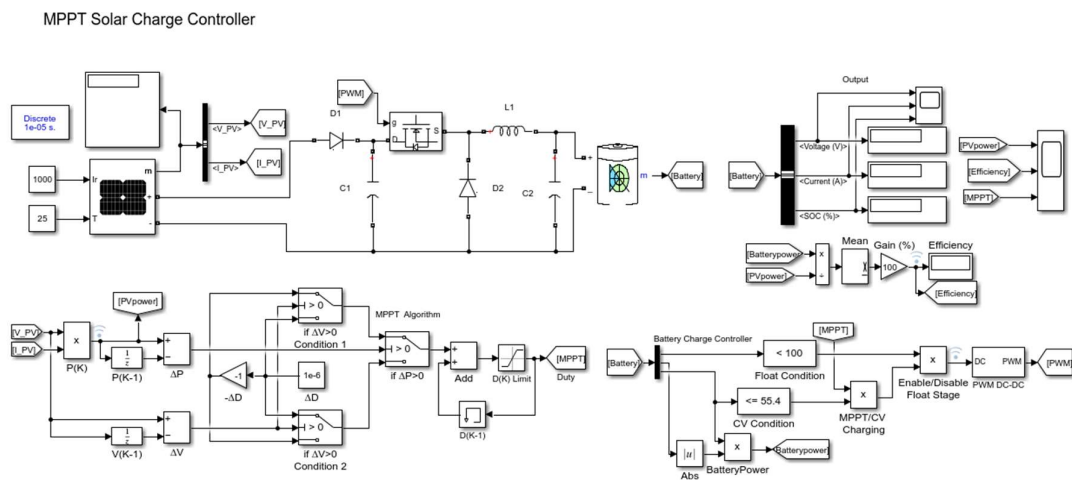

Fig :07 MPPT (Maximum Power Point Tracker) Charge Controller

Regardless of whether the sun is shining or the temperature is rising, the full Power Point Tracking (MPPT) based charge controller will always be able to charge the battery at its full

potential. The MPPT-based charge controller incorporates a DC-DC converter within its architecture. DC-DC converters are also known as switch mode regulators. Transformers may be thought of as analogous to DC-DC converters in how they function. The output voltage may be more than or less than the input voltage. The output voltage of a boost converter is higher than the input voltage, whereas the output voltage of a buck converter is lower than the input voltage. If you need to raise or lower the voltage at the output, a buck-boost converter is your best option. MATLAB Simulink is used once again for the second design. Six photovoltaic arrays (SunPower SPR 445J WHT D) are used here as well. The two sets of information are linked by two parallel and four series connections. Cells were exposed to 1000 W/m² of radiation at 25 degrees Celsius. For the sake of our comparison research to determine which option is best, we maintained continuity with design 1. This MPPT algorithm modifies the duty cycle of the pulses used to regulate the gate of the MOSFET switch. Tracking the MPP requires constant monitoring of the voltage and power output fluctuations of the PV panels. This ensures that the load always gets the maximum power and decreases the steady-state inaccuracy caused by oscillation around the MPP by adjusting the duty cycle of the gate pulses in response to the fluctuation. The MPPT algorithm controls the duty cycle of the pulses that operate the MOSFET switch's gate.

Output Results and Waveshapes of MPPT:

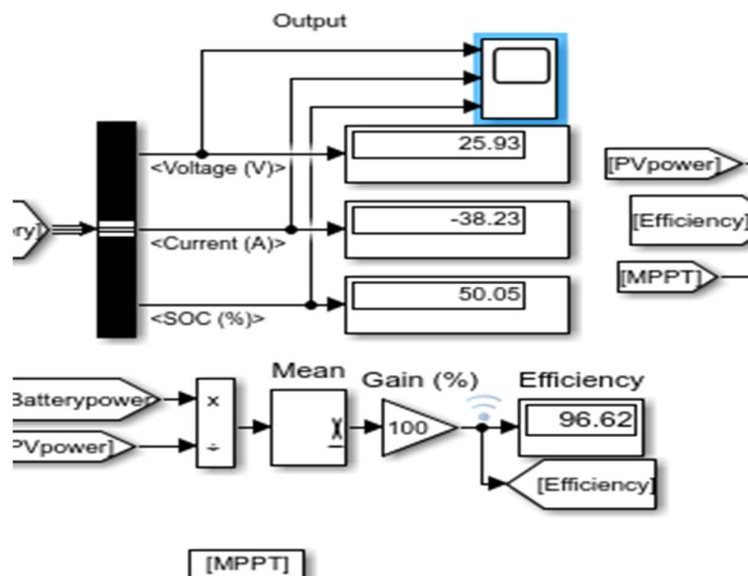

Fig:08 Output Results of MPPT (After Zoom In from the circuit)

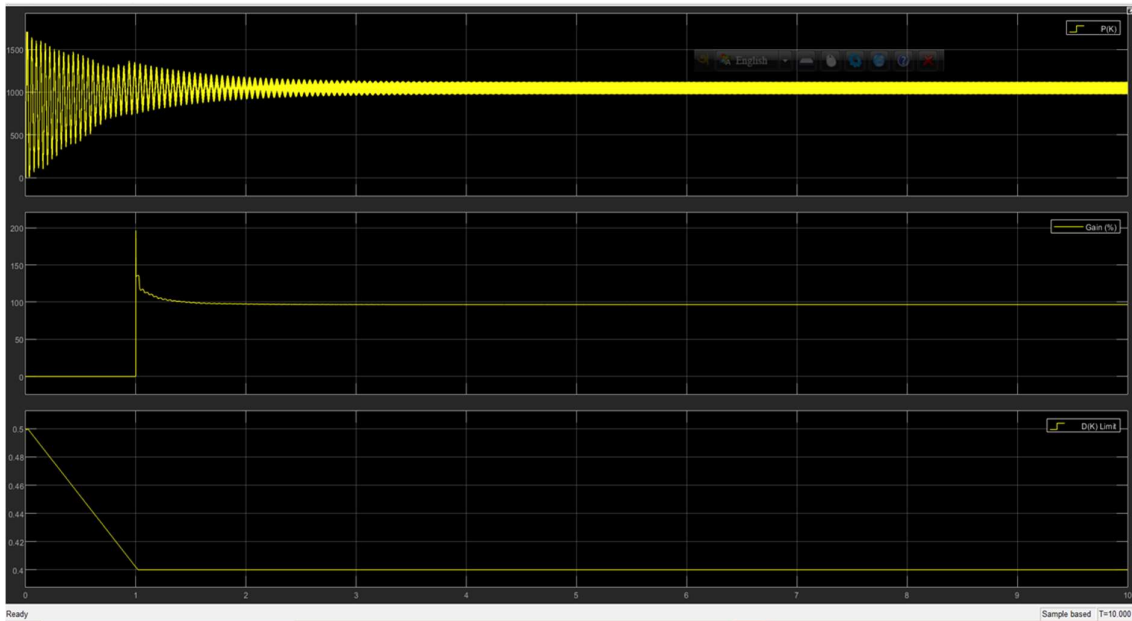

Fig: 09 output wave shapes of PV power, MPPT gain and Duty cycle

Here x- axis is for Time and y axis for the measured value (Time Vs PV power, MPPT gain and Duty cycle)

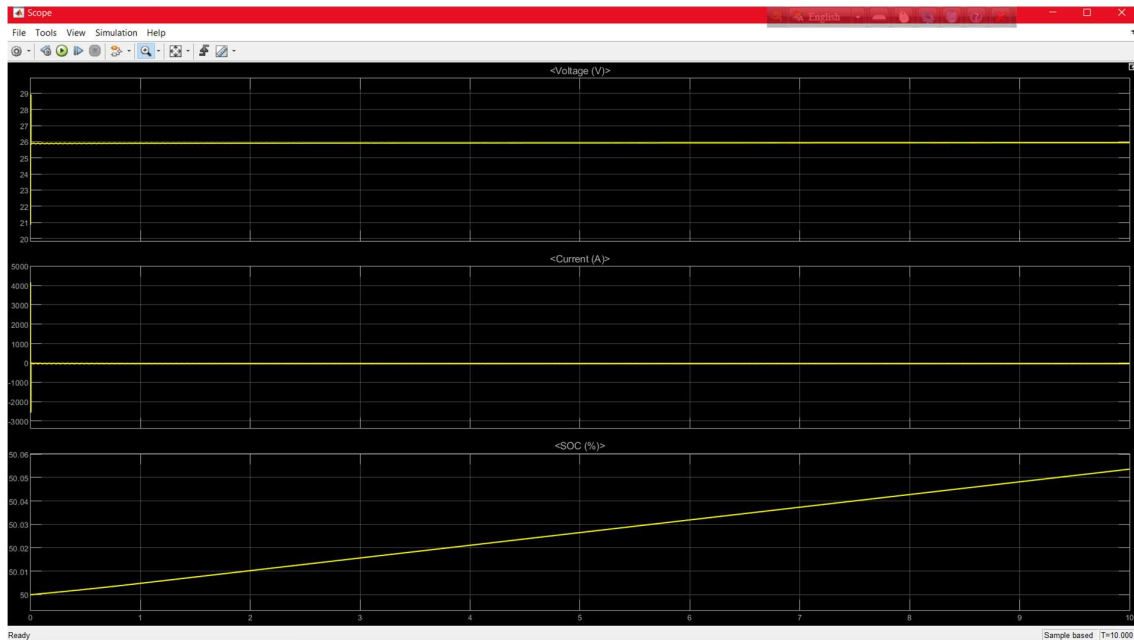

Fig:10 Graphs for output Voltage ,current and SOC(%)

Here x- axis is for Time and y axis for the measured value [Voltage, current and SOC (%)]

Here at the girls graph we could see the output voltage, at the second graph, we could see the output current and the last one is for SOC (%).

Basis of analysis:

Simulink runs time: 10

Table:07 parameter values of MPPT

Parameters	Value
SOC (%)	50.05 (initial SOC 50%)
Output Voltage (battery)	25.93 V
Output Current (battery)	38.28 A
Power (P=VI)	992.61 W

Design 3:

Shunt Charge Controller:

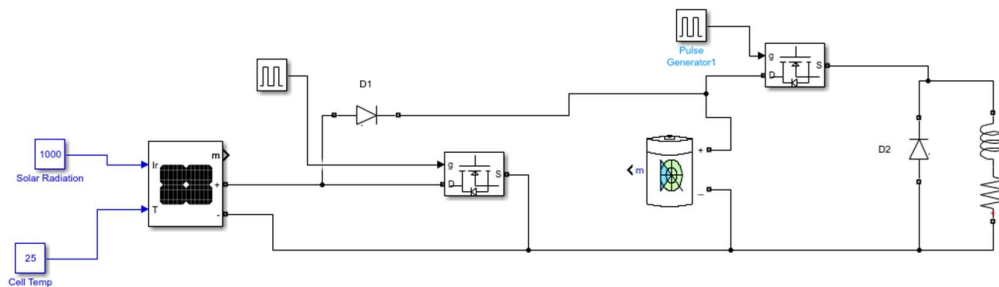

Fig:11 Shunt Charge Controller

Output:

We didn't get proper Output for the Shunt Charge controller.

4.3 Identify optimal design approach

Based on our literature review and simulation, we have got some features to compare between the designs like Table:08 to get our optimal solution.

Table:08 parameter values of Optimal design approach

Basis	PWM	MPPT
Efficiency	Medium (62.41)	Higher (96.64)
SOC (%)	50.03 (Initial SOC 50%)	50.05 (initial SOC 50%)
Output voltage of battery	Lower (25.9)	Higher (26.12)
Output Current (battery)	24.57 A	38.28 A
Power (P=VI)	636.363 W	992.61 W
Expense	Less [8]	Higher [8]
Complexity	Less [8]	Higher [8]
Battery Life	Medium [12]	Higher [12]
Performance in between Temperature	Suitable for warm temperature [12]	Suitable for Cold temperature [12]

From the above table, we can see some difference between PWM and MPPT on their efficiency, power, expense, complexity etc. In the table we can see the efficiency of PWM is 62.41. However, the efficiency of the MPPT charge controller is 96.64, which is higher than PWM charge controller. State of charge of the PWM is 50.03% but for MPPT it is 50.05%. Which is better than PWM. Output voltage of the battery of PWM is 25.9 and for MPPT it is 26.12 which is higher than PWM. Output current for PWM is 24.57 but for MPPT it is 38.28 which is more than PWM. We can see that power generated by PWM is 636.363W. MPPT can produce 992.61W, better than PWM. The cost for PWM is less than MPPT. Complexity is higher for MPPT but PWM is much easier. Battery life span for MPPT will be extended. But for PWM it will be medium or less. PWM charge controller is suitable for warm temperatures. But MPPT is better for cold temperatures.

Weighted Decision Matrix For Technology Analysis:

Table:09 Weighted Decision Matrix

Designs	Design complexity	Solar Energy Detection	Battery Longevity	Suitability for every weather condition	Efficiency	Temperature	Cost Efficient	Steady state Oscillations	Total Rating
	Out of 20	Out of 15	Out of 15	Out of 15	Out of 15	Out of 10	Out of 5	Out of 5	Out of 100
1. MPPT	Above Average	Above Average	Above Average	Excellent	Above Average	Excellent	Average	Excellent	72
	14	10	11	13	10	8	3.5	4	
2. PWM	Average	Average	Average	Above Average	Average	Excellent	Average	Below Average	61
	13	8	8	10	8	8	3	2.5	

Excellent ■
 Above Average ■
 Average ■
 Below Average ■

4.4 Performance evaluation of developed solution

Pulse Width Modulation Charge Controller (PWM)

Efficiency: This project's primary goal is to develop a low-cost, effective charge controller. The PWM controller is cost-effective but after simulation, we saw that PWM is not efficient in terms of giving output voltage and output current. We got an output voltage of 25.9 Volt and an Output current of 24.57A. Calculated efficiency is 62.41%

Tracking maximum power: In our simulated pulse width modulation charge controller tracking power was 636.362 watts. After multiplying the voltage and current we got this value. But we expected more power than this. Because one of our main focuses is to get maximum power from a charge controller.

Battery Charging Time: One of the biggest problems with secondary batteries is the duration of charging. This parameter shows how long it takes to fully charge a totally drained cell. Charging time is one of the main challenges of secondary batteries. In the simulation, we set our battery soc (%) to be 50%. Our Simulink run time was 10. Then we got SOC (%) 50.03%.

Prevent Overcharging and extending battery lifespan: The main function of solar charge controllers is to prevent batteries from overcharging. And PWM is one of the most usable charge controllers. Though this system is not preferable for all kinds of weather, its importance

in preventing batteries from overcharging is beyond describing. By this, the lifetime of the batteries becomes longer and ensures that the deep cycle batteries aren't overcharged during the day and that the batteries aren't drained at night by power running back to the solar panels.

Maximum Power point tracker charge controller (MPPT)

Efficiency: This project's primary goal is to develop a low-cost, effective charge controller. In the simulation, we got that MPPT is efficient in terms of giving output voltage and output current. We measured the efficiency as 96.64% which is much more efficient than the PWM charge controller.

Tracking maximum power: In our simulated MPPT solar charger controller tracked power was maximum. After multiplying the voltage and current we got this value. So in terms of Tracking maximum power MPPT charge controller was preferable for us to choose.

Battery Charging Time: One of the biggest problems with secondary batteries is the duration of charging. This parameter shows how long it takes to fully charge a totally drained cell. Charging time is one of the main challenges of secondary batteries. In the simulation, we set our battery SOC (%) to 50%. At Simulink run time 10 we got an SOC of 50.05. So we can easily understand that by MPPT charge controller battery charging time is reduced.

Prevent Overcharging and extending battery lifespan: The optimum function of any charge controller is to prevent batteries from overcharging. And there are various kinds of solar charge controllers in the market. But from all the charge controllers, MPPT plays the most vital role in any PV system in any kind of weather condition. Again, this system is able to protect the batteries from overcharging most efficiently. However, MPPT ensures that it will draw the most favorable amount of current from the panels and deliver this to the battery with as little losses as possible. This function lengthens the lifespan of the battery and helps it to work more efficiently throughout the system for a long time.

4.5 Conclusion

Solar charge controllers are required to utilize solar energy successfully and sustainably. They regulate the amount of electrical charge delivered from solar panels to batteries, ensuring that the batteries are charged at the right rate and voltage, hence extending battery life.

Modern solar charge controllers also employ cutting-edge technology and energy-saving technology to reduce energy waste and improve overall system efficiency. These elements are all part of the MPPT solar charge controller design philosophy, which emphasizes sustainability. As solar power technology progresses, the performance and sustainability of solar charge controllers are always being investigated and enhanced.

Chapter 5: Completion of Final Design and Validation. [CO8]

5.1 Introduction

The increasing demand for renewable energy has led to the adoption of solar energy as a promising alternative source of power. An MPPT (Maximum Power Point Tracking) solar charge controller is frequently used to improve the efficiency of solar power systems. An MPPT controller is a device that improves the energy harvesting process by regulating the voltage and current from the solar panels to fit the requirements of the battery bank. This helps to shorten battery charging time and avoid overcharging, hence increasing battery life. The purpose of this research is to investigate the design and implementation of a low-cost MPPT solar charge controller capable of lowering battery charging time and preventing overcharging. The proposed design is expected to be cost-effective and accessible to households and small businesses that wish to harness the power of solar energy without incurring high costs. This project will first provide an overview of the basics of solar energy and the need for MPPT solar charge controllers. The project will then review the existing literature on MPPT controllers, focusing on their working principles, design considerations, and performance evaluation. The proposed low-cost MPPT controller design will be presented in detail, including its circuit diagram, components selection, and testing results. In conclusion, this project aims to contribute to the advancement of the field of renewable energy by providing a low-cost solution for optimizing the energy harvesting process in solar power systems. By reducing battery charging time and preventing

5.2 Completion of final design

5.2.1 Design Methodology and Design Process

MPPT charge controllers (Maximum Power Point Tracking) are electrical devices used to charge batteries from solar panels. They operate by constantly changing the voltage and current provided by the solar panels in order to collect the most electricity from them. The MPPT charge controller approach is intended to improve charging efficiency and battery life. Three MOSFETs, voltage regulators, current sensors, transistors, capacitors, a battery, a PV array, and a microprocessor comprise the MPPT charge controller. MOSFETs are used to regulate the flow of power from solar panels to batteries and loads. The voltage regulator regulates the microcontroller's voltage, ensuring steady functioning. The current sensor detects the passage of current via the circuit. The MPPT charge controller has two modes of operation: bulk mode and float mode. Bulk mode is a fast charging option that charges the battery as quickly as possible. The controller permits the greatest amount of current to pass from the solar panels to the battery, up to a voltage limit of 12V. The MOSFET for charging is fully turned on in this mode, ensuring maximum current flow. Float mode is a slow charging mode where the battery is charged at a lower rate to prevent overcharging. The controller reduces the current flow to

the battery, and the MOSFET for charging is partially turned on, allowing only a limited amount of current to flow. In float mode, the voltage limit is increased to 13V, and the battery is charged until it reaches this voltage. To manage the charging current, the MPPT charge controller employs PWM (Pulse Width Modulation). PWM is a mechanism in which the controller rapidly turns on and off the MOSFETs, managing the average voltage and current provided to the battery. The duty cycle of the PWM signal controls the charging current by determining how long the MOSFET is active.

The MPPT charge controller's microprocessor monitors the battery voltage and current and changes the duty cycle of the PWM signal to keep the charging voltage and current at the correct levels. The microprocessor is also in charge of controlling the MOSFETs that switch the load, allowing the battery to power external devices.

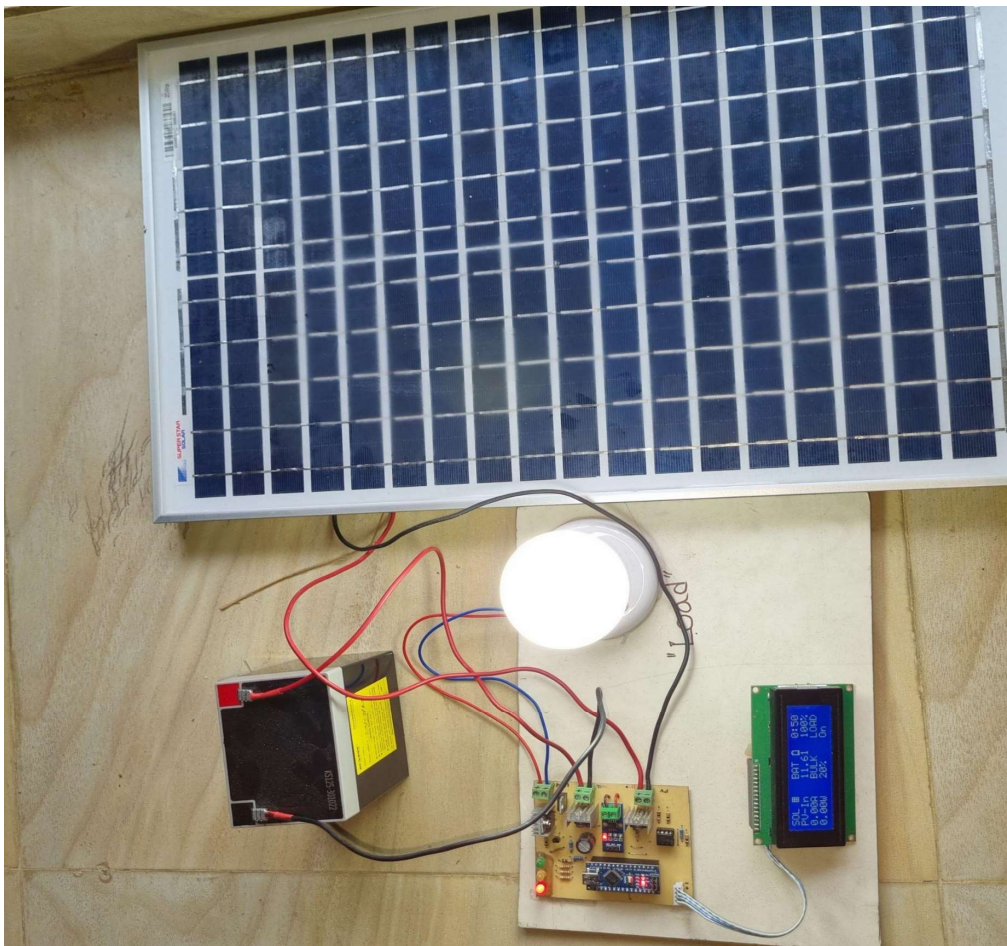

Fig: 12 Hardware Setup

To prevent overcharging and battery damage, the MPPT charge controller has several safety features. The charger cuts off when the battery voltage reaches 13V to prevent overcharging. The charger reconnects when the battery voltage drops to 10V. The load is cut off when the battery voltage drops to 10V to prevent deep discharge.

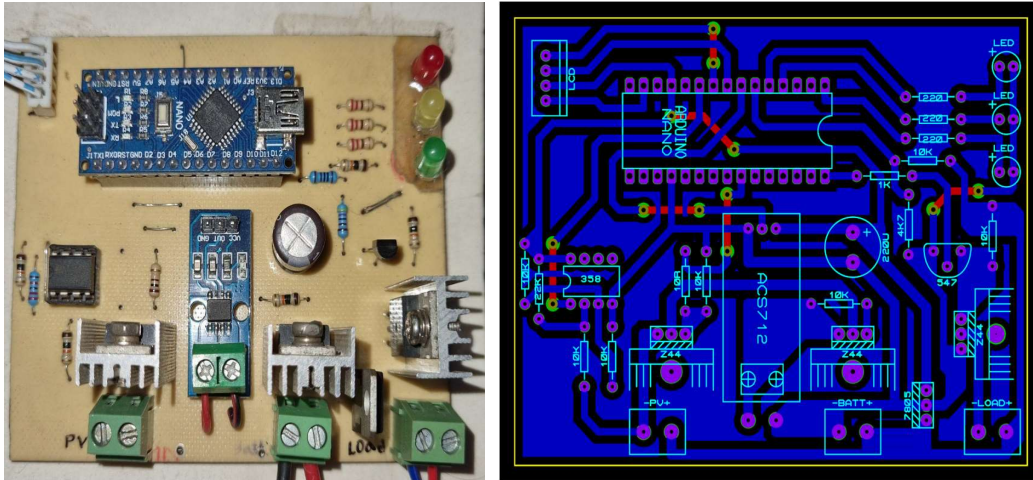

Fig: 13 Hardware circuit and PCB design.

In summary, the MPPT charge controller methodology is designed to optimize the charging process of solar batteries. It uses PWM to regulate the charging current and has two modes, bulk mode and float mode. The microcontroller monitors the battery voltage and current and adjusts the duty cycle of the PWM signal to maintain the desired charging voltage and current. The MPPT charge controller also has several safety features to prevent overcharging and battery damage.

5.2.2 Data Collection and Analysis

To monitor the data we used an LCD display. In the Display we will see 3 parts. First part we will see the PV array's data then in second part we will see Battery's information and at last part we will see timer and Load connections information.

Here we set two modes, one is BULK mood and another is Float mood to reduce the charging time.

In order to ensure that the battery is charged properly, the maximum power point tracking (MPPT) solar charge controller continuously measures the voltage and current output of the solar panels and modifies the charging parameters. The controller can regulate the charging current and voltage by adjusting the duty cycle of the pulse width modulated signal. This is accomplished via the use of the PWM technology. This makes it feasible for the controller to keep the voltage of the battery at the ideal level while simultaneously charging the battery as rapidly as possible. The controller will continue to provide a steady current to the battery while it is in the bulk charging mode until the battery voltage hits the threshold that was previously established. When it reaches this threshold, the controller will change charging modes to one that maintains a constant voltage. In this mode, the charging current will progressively decrease until it reaches zero, at which time the battery will be completely charged. Because it uses pulse width modulation (PWM) to control the charging current and voltage, the MPPT solar charge

controller can charge the battery more quickly and efficiently than traditional solar charge controllers. PWM is used in the bulk charging mode to manage the charging current and voltage. This helps to cut down on the amount of time needed to charge the battery while also ensuring that the battery is charged effectively. We decided to make the restriction voltage for the BULK charging at 12V. When it reaches 12 volts, it will begin charging in the Float mood.

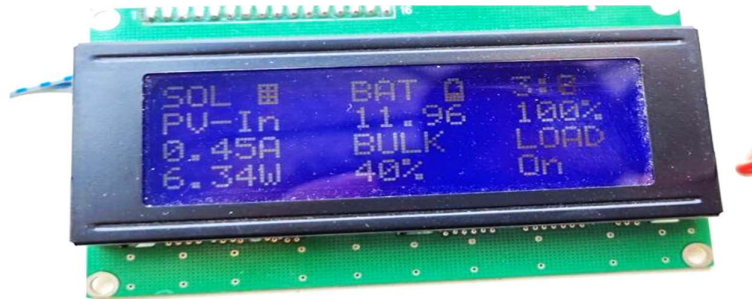

Fig:14 BULK Charging MOOD

When the battery voltage reaches 12V, the float mood begins to take effect. The controller implements a Pulse Width Modulation (PWM) strategy while it is operating in the float mode in order to keep the voltage of the battery at a stable level. PWM is a method in which the controller turns the charging current on and off extremely fast and at a high frequency. PWM is an acronym for pulse width modulation. The controller is able to keep the battery voltage stable by regulating the ratio of the on-time to the off-time such that the on-time is longer than the off-time. The controller performs a continual monitoring of the battery voltage and makes appropriate adjustments to the PWM duty cycle. The PWM duty cycle is progressively decreased by the controller when the voltage of the battery increases from 12V to 13V. This causes the charging current to gradually decrease, which in turn slows down the pace at which the battery is being charged.

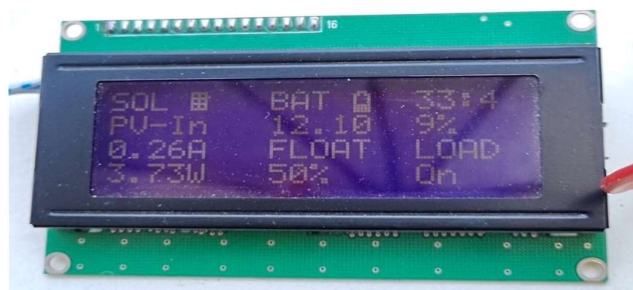

Fig:15 FLOAT Charging MOOD

The overcharging of a battery may cause physical damage to the battery, shorten its lifetime, and even generate potential safety issues such as an explosion or fire. As a result, these charge

controllers are designed to prevent the battery from being overcharged. They achieve this by keeping an eye on the battery's voltage and turning off the power to the charging source when the battery is fully charged. The charging procedure will be terminated by the charge controller whenever the voltage of the battery hits 13 volts, which is most likely the highest amount of voltage that the battery can safely manage. This will prevent the battery from being overcharged and will guarantee that it is kept at a level that is safe for use. It is essential to be aware that the precise voltage level at which the charge controller terminates the charging process might change. This is because the kind and model of the charge controller, in addition to the type of battery and its capacity, all play a role in this variable. In addition to this, it is essential to appropriately setup and set up the charge controller in order to guarantee that it performs as intended and offers the necessary amount of safety for the battery.



Fig:16 Auto Charging Cut OFF.

In this fig-16 we can see that PV is on but the charger is off. Once the battery voltage reaches down to 10V then the charger will reconnect and start charging. Then Load will be off when its battery voltage reaches 10V. By this process, the battery will be safe from physical damage and battery lifespan will expand. We can change the battery voltage level of BULK mood, FLOAT mood, Charging cut off, charger reconnect and load off by changing the value of our microcontroller's code.

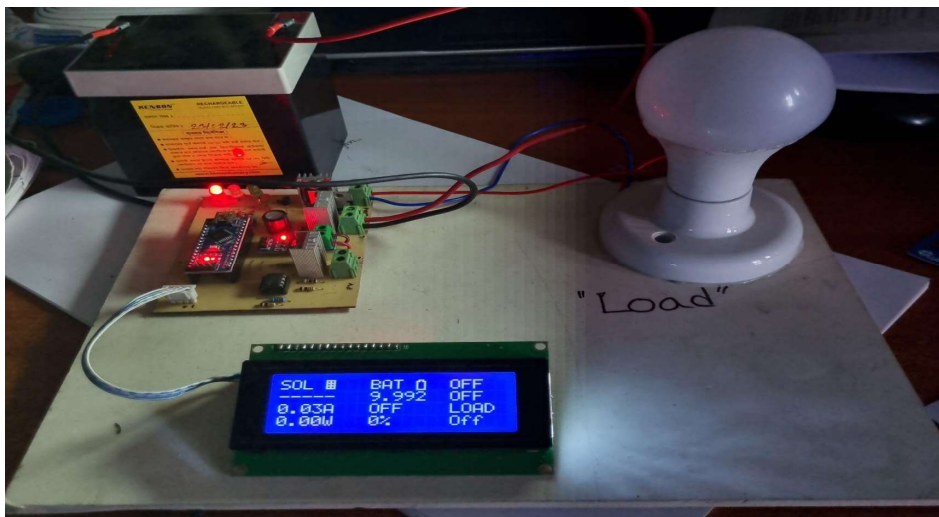

Fig: 17 Load Auto Cut OFF

Here in fig 16, we can see the load connected with the controller but battery voltage is less than 10V, that's why load was not in ON state.

5.3 Evaluate the solution to meet desired need

Any solar power system must include a solar charge controller because it regulates the amount of electricity that is delivered from the solar panels to the batteries. We considered the following elements to make sure our demands would be satisfied:

Charge Controller: our main objective was to design a Solar charge controller.

Efficiency: Try to choose a solar charge controller that has a good rating for its efficiency. Because of this, your solar panels will be able to transfer the maximum amount of electricity that they generate to your batteries, thereby reducing the amount of energy that is wasted.

Charge rate: The charge rate of a solar charge controller is what decides how quickly your batteries may be charged by the controller. You should look for a controller that has a high charge rate because this will considerably cut down the amount of time needed to charge your batteries.

Battery compatibility: Ensure that the solar charge controller you choose is compatible with the type and capacity of your batteries. This can help to maximize the life of your batteries and avoid damaging your batteries in the process.

Price: The cost of a solar charge controller can range widely, although a high-quality controller does not always have to be very expensive. Take into account your financial constraints, and hunt for a controller that can fulfill your needs while remaining inside your price range.

A number of particular suggestions for solar charge controllers include the following:

Maximum Power Point Tracking (MPPT) Solar Charge Controller: In comparison to PWM (Pulse Width Modulation) charge controllers, MPPT (Maximum Power Point Tracking) charge controllers are significantly more effective and can deliver up to thirty percent more power. The Victron Energy MPPT Solar Charge Controller is a fantastic choice because it has a high charge rate and is compatible with a variety of different types of batteries.

PWM Solar Charge Controller: PWM charge controllers are appropriate for smaller solar power systems and are often cheaper than MPPT charge controllers. The Renogy Wanderer 10A PWM Solar Charge Controller is an outstanding choice that is favorable to one's wallet and provides a rapid charging rate.

Shunt Charge controller: To put it simply, a shunt controller is a toggle switch. When the battery voltage is low, or when the battery requires charging, the switch opens and current flows from the solar panel array to the battery. The moment the switch is switched off, the battery is regarded as completely charged. The simplest controller design is the shunt controller; however, it is also the most inefficient at charging batteries. (Consider the difficulty of filling a glass from a kitchen tap that only has two positions: off and fully on.) There are currently only a few numbers of shunt controllers available, and they are often reserved for niche uses.

In general, deciding on a solar charge controller that is tailored to your particular requirements as well as your financial constraints is one of the best ways to cut costs and lessen your reliance on conventional forms of power, which is especially important during periods of fluctuating fuel prices and intermittent power outages.

Performance Evaluation:

Charge controllers with the acronym MPPT, which stands for "Maximum Power Point Tracking," are designed to improve the overall efficiency of solar panels. To do this, they manipulate the voltage and current levels in a way that allows them to harness all of the power that a solar panel is capable of producing. This is done in order to maximize the quantity of energy that can be harvested. In order to evaluate how well MPPT charge controllers work in a range of different climatic conditions, there are a few different kinds of experiments that may be carried out.

1)Testing in Sunny Weather: Maximum power point tracking charge controllers are designed to perform at their highest level of efficiency when exposed to strong direct sunshine. When the weather is clear and sunny, it is feasible to determine how well MPPT charge controllers are working by monitoring the output voltage and current of the solar panels. By comparing the values that were actually measured with the values that were predicted, it is possible to evaluate the efficiency of the MPPT charge controller.

2)Testing in Cloudy Weather: If there is a reduction in the amount of sunlight that is able to reach the solar panel as a result of cloudy weather, then there is a possibility that there will be a drop in the amount of power that is generated by the panel. It is possible to assess the effectiveness of MPPT charge controllers even on overcast days so long as the output voltage and current of the solar panel are being watched. By contrasting the values that were obtained with the values that were anticipated to be measured under these weather circumstances, it is feasible to assess the performance of the MPPT charge controller.

3)Testing in Low-Light Conditions: The most significant source of electricity Even when the light levels are low, tracking charge controllers are intended to get the most amount of electricity possible from the solar panel. If the output voltage and current of the solar panel are observed, it is possible to assess the efficiency of MPPT charge controllers even when they are being utilized in conditions with low amounts of available light. By contrasting the values that were obtained with the values that were anticipated to be measured under these weather circumstances, it is feasible to assess the performance of the MPPT charge controller.

4)Testing in Extreme Weather Conditions: MPPT charge controllers are designed to work in a wide range of climatic conditions, including those that are quite severe. The performance of MPPT charge controllers may be evaluated under adverse environmental conditions, such as high temperatures or heavy rainfall, by monitoring the output voltage and current of the solar panel. This enables one to determine how well the controller’s function in these conditions. It is possible to carry out this assessment in a number of different settings. By contrasting the values that were obtained with the values that were anticipated to be measured under these weather circumstances, it is feasible to assess the performance of the MPPT charge controller.

In general, the output voltage and current of the solar panel may be measured and compared to the anticipated values in order to assess the efficacy of MPPT charge controllers in a variety of climates. This can be done in a number of different environments. This is something that can be done in a range of various climates and conditions. It is possible that this will be of assistance in assessing whether or not the MPPT charge controller is successful, as well as whether or not it is able to extract the largest amount of power possible from the solar panel under a wide range of climatic conditions.

Table:10 Project Object

Basic	Design of Charge Controller for Solar PV Systems
Design an efficient solar charge controller at a low cost	Possible
Tracking Maximum Power	Possible
Prevent Overcharging	Possible
Extending battery lifespan	Possible
Reducing the charging time	Possible

Our ultimate objective is to design a charger controller to fulfill our desired requirements.

Table :11 Evaluate the Model results with the desired needs

Objective	Result	Fulfill our desired need (YES/NO)
Design an efficient solar charge controller at a low cost	Designed MPPT charge Controller	YES
Tracking Maximum Power	MPPT Charge controller	YES
Prevent Overcharging	Charging Auto Cut Off at 13V of battery charge.	YES
Extending battery lifespan	By preventing overcharging and Auto load cut off when battery voltage will be less than 10V.	YES
Reducing the charging time	BULK MOOD: Fast Charge Up-to 12V	YES
	FLOAT MOOD: From 12V to 13V gradually slow charge to prevent overcharging and physical damage of battery.	

NB: we can change the range of the Voltage which is mentioned above by our microcontroller command.

Table 12: Data Table

Charging Mood	Charging Range (Volt)	Charging Time for 2V (From 10V-12V)	Charging Auto Cut OFF (Volt)	Load Cut OFF (Volt)	Charger Reconnect
Bulk	Up to 12 volts	5 minutes	13 V	10V	10V
Float	12V - 13V	46 minutes			

According to the inspection of each one of our project plans, After much hard work and dedication, we are pleased to report that we have successfully achieved the project goals that

were set out at the beginning of this endeavor. The members of our team have put in a lot of hard work to ensure that the project was well-planned and -executed, and we are happy to say that our efforts have been fruitful. We never lost sight of the end goal and worked diligently to ensure that every action we took brought us closer to accomplishing what we set out to do. As a result of working together and drawing on the knowledge and experience of everyone who was involved in the project, we were able to triumph over challenges and obstacles that arose as a result of the project.

In general, the MPPT charge controller project has been a remarkable success, and it is without a doubt that its continued success will help to the development of technologies that utilize renewable energy sources. In light of the growing need for renewable energy sources, the use of an MPPT charge controller is one of the most efficient ways to make the most of one's solar energy resources, reduce one's carbon footprint, and enhance one's energy efficiency.

5.4 Conclusion

In conclusion, the MPPT solar charge controller is a very effective and economical way to use solar energy to charge batteries. The controller excels in a variety of applications due to its key characteristics, which include affordability, a shorter battery charging time, and the prevention of overcharging. The MPPT solar charge controller is made to follow the solar panel's greatest power point, ensuring that the battery is charged as efficiently as possible. This not only speeds up the charging process but also maximizes the solar panel's power production, saving you a lot of money over time. Moreover, the controller's ability to prevent overcharging helps to extend the battery's lifespan, thereby reducing maintenance costs. This feature also ensures the safety of the battery and the connected devices, protecting them from any potential damage. Overall, the MPPT solar charge controller is a reliable and cost-effective solution that offers numerous benefits. Its ability to reduce battery charging time, prevent overcharging, and low cost make it a popular choice among consumers looking for a sustainable and efficient way to charge their batteries using solar energy.

Chapter 6: Impact Analysis and Project Sustainability. [CO3, CO4]

6.1 Introduction

Solar PV systems are becoming more and more familiar day by day. It is very important to retain the maximum use of Solar PV systems but efficiently. And our designed low cost charge controller will ensure it. As our controller is at minimum cost with maximum efficiency it will increase the future use of Solar PV systems. This research will have an impact on the maximum use within low cost.

6.2 Assess the impact of solution

Every project has different impacts on multiple areas. Ours is no exception. In a variety of ways, our solar charge controller project will be beneficial and notable. Energy is one of the most useful resources in our everyday life and by efficient use of energy, we can improve our life more. Nowadays most people use solar PV cells. And as our controller will ensure efficient use it will have a great impact on social, economical, and other sectors.

Societal and cultural context

Our project has a significant impact on our social and cultural context.

- As the charge controller increases the lifespan of the battery, more renewable energy can be used. So, the use of nonrenewable energy will decrease
- As a renewable source of power, solar energy has an important role in reducing greenhouse gas emissions and mitigating climate change. As we are making a charge controller, this will boost the use of solar panels.
- The recycling process of solar controllers has not created enough awareness yet. Solar modules can be disposed of with other standard e-waste. For this reason, there is a huge chance of causing environmental pollution.

Health context

Our project has a significant impact on health.

- With solar panels no air pollution or greenhouse gas has not emitted the chance of people getting harmed or getting health problems is quite less.
- In this process, so many chemicals (silicon, hazardous chemicals) are used frequently. Most of the time these chemicals are not byproduct properly. For this reason, people can suffer from

various kinds of diseases like skin problems, tuberculosis, chest infections, heart problems, and so on.

Safety context

Our project has a significant impact on safety.

- Protects from electric hazards caused due to use of nonrenewable energy
- As solar controllers and solar panels are needed to be placed in an open place, sometimes it is risky for people as it can cause electrocution.

Economical context

Our project has a significant impact on the economical context.

- Our controller will be at a low cost which will increase the number of users and economic benefit
- Our more efficient charge controller will increase the use of solar panels and will help increase economic conditions.

6.3 Evaluation of the sustainability

Our project is considerably more affordable, simpler and better suited for everyday use. Our device is superior to other ones in the market in terms of efficiency. Our primary goal is to give people a low-cost controller which will be more efficient compared to other controllers. Solar charge is a clean and renewable energy source that can help to reduce our reliance on non-renewable energy sources. Solar charge controller ensures that Solar power systems work efficiently and effectively. It helps to prevent overcharging and undercharging and increase the lifespan of the battery. To make it more sustainable modern technologies are used which helps to reduce energy waste and improve overall system efficiency. Many solar charge controllers are made with environmentally friendly materials to reduce environmental pollution.

6.3.1 Maintainability and Manufacturing

Since the design of this system is complex, we need proper maintenance. Additionally, we need to properly evaluate the power capacity of the sensors since we are connecting them to the same esp. A few things need to be examined as part of routine maintenance, such as dusting and, if required, upgrading the software. We can perform inexpensive maintenance to ensure that our product is functioning effectively. Once a year, a charge controller needs to have its

wire connections checked to make sure they are clean and secure. The performance of the system is negatively impacted by resistance and heat that are produced by a loose connection. As there are different kinds of sensors used, we must be aware of checking them. We have to check if the wires are connected properly because if they are not there may cause a short circuit. Also, we need to give a proper connection of solar PV cells with the battery.

6.3.2 Sustainability

This method will provide the safety of the battery with more efficiency. As a solar panel cannot control the amount of sunlight so there is a chance that the battery may overcharge or undercharge. Here this controller will ensure that the battery is charged as required. And since this is automated there is less chance of error. As this will increase the efficiency so this design will be more long lasting.

Once a year, as part of the maintenance that must be performed on the charge controller, the wire connections must be examined to confirm that they are clear of debris and that they are correctly secured. When a connection is not properly secured, it may cause resistance and heat to build up, both of which are detrimental to the proper functioning of the system.

It is possible that including a solar charge controller into a solar storage system might be beneficial. When a customer purchases a solar storage system, they are offered the choice to use solar electricity off-grid either permanently or temporarily as a source of backup power in the event that they have a power outage. The controller's job is to keep the backup battery supplied with the appropriate quantity of power at all times. This guarantees that the battery does not exceed the voltage capacity for which it was built, which in turn protects the battery from injury and increases the amount of time it can function for. Depending on the kind of solar storage system that you have, you could need to make use of a solar charge controller or you might not need to make use of one at all. In this article, we will discuss all there is to know about this instrument so that you have a complete understanding of it.

In its most basic form, a solar charge controller is only a solar battery charger that is connected in series with the solar panels and the storage battery. A solar charge controller is also known by its alias, the term "solar regulator." It is responsible for controlling the process of charging the battery and ensuring that the battery is charged adequately and, more importantly, is not overheated. It also ensures that the battery does not get an undercharge. Solar charge controllers that are DC-coupled have been on the market for decades and are now employed in the vast majority of residential and commercial solar power systems that are not linked to the grid. Modern solar charge controllers come with a range of extra capabilities, some of which are used for lighting, such as a DC load output. These additional capabilities may be found on modern solar charge controllers. Because of these features, the battery system is guaranteed to be charged accurately and efficiently. When determining ratings for solar charge controllers,

both the maximum charge current (in amps) and the maximum input voltage (in volts) are taken into consideration. The maximum number of solar panels that may be connected to the charge controller at the same time is determined by these two ratings, which are discussed in more depth further down in this section. When solar cells are connected to one another in a series connection, the resulting structure is known as a string of panels. Solar cells are typically linked to one another in a parallel connection. The number of panels connected in series will result in an increase in string voltage that is proportional to that increase.

By using the method that we have selected, we are able to achieve the highest level of accuracy that is feasible. It made it feasible for us to get the highest possible quantity of power at the most affordable price.

We can determine from an analysis of our project that it satisfies all requirements and is sustainable.

Table:13 Weighted decision matrix for technology analysis

Sustainability criteria process	Technical (25)	Economic (25)	Social (25)	Environment (25)	Weighted sum (100)
Designing	25	20	15	20	80
Solar Charge Detection	25	20	15	20	80
Battery Longevity	25	20	20	20	85
Device Operation	20	15	15	20	70
Efficiency	25	20	20	20	85
Cost efficient	25	20	15	15	75

6.4 Conclusion

In conclusion, it can be said that the project of a more efficient solar charge controller helps in the use of Solar PV cells. When using a Solar PV Cell, its maintenance is very important. If a charge controller is not used, the battery will damage soon, affecting Solar cell. To increase the use of Solar cells properly and to make it more sustainable for the future a well-designed controller is important. From the above analysis of data, we can conclude that our device met all the requirements (social impact, health impact, safety impact) and sustainability.

Chapter 7: Engineering Project Management. [CO11, CO14]

7.1 Introduction

Project management that is only concerned with engineering projects is referred to as engineering project management. All styles of project management use the same fundamental techniques and methods. This specialization will undoubtedly be fascinating to anyone with a technical background who wants to work in project management. Engineers in charge of projects must carefully consider their strategy and convey it to their engineering team. Determine the project's objectives, milestones, and backup plans, as well as potential eventualities. Without it, the unexpected could occur and prevent dozens or even hundreds of personnel from completing their assignment, making it an essential step for every engineering team. Engineering project management is intricate and demands strong administrative, communication and interpersonal abilities. Engineering project management requires careful consideration of several logistical aspects. The project manager must be able to plan out and direct the course of a project in order to keep everyone involved on the same page. Naturally, the project manager must be able to promptly and affordably resume work on the project in the event that something goes wrong.

7.2 Define, plan and manage engineering project

Since the beginning, we have followed a few project plans to complete the project, as illustrated in Figures 35, 36, and 37. In order to achieve our predetermined objective, it was crucial to manage the project plan. To finish this project within the three semesters of FYDP-P, FYDP-D, and FYDP-C, we had to carefully prepare our strategy.

EEE-400P:

Task Name	Responsibility	Weeks													
		Week-01	Week-02	Week-03	Week-04	Week-05	Week-06	Week-07	Week-08	Week-09	Week-10	Week-11	Week-12	Week-13	Week-14
Topic Selection	Everyone	█	█	█	█										
Literature review: Finding gaps, multiple Design, Specifications	Liya				█	█									
Specifications, Requirements & constraints Analysis	Sijan				█	█	█					█	█		
Preparing for progress presentation 1	Everyone				█	█	█								
Concept Note drafting	Everyone				█	█	█	█							
Optimal solution finding	Moazzul							█	█	█	█				
Equipment selection	Laila								█	█	█				
Budget and Planning	Jawad									█	█	█			
Sustainability	Moazzul										█	█	█		
Applicable standard and codes	Jawad											█	█		
Risk management and safety consideration	Laila											█	█		
Project Proposal drafting	Liya												█	█	
Preparing for progress presentation 2	Everyone												█	█	
Project Proposal report	Everyone												█	█	█

Fig:18 Project plan EEE-400P

EEE-400D:

Task	Responsibility	Week-01	Week-02	Week-03	Week-04	Week-05	Week-06	Week-07	Week-08	Week-09	Week-10	Week-11	Week-12	Week-13
		Preparing Design process	Everyone	█										
Primary design of multiple approaches	Sijan & Moazzul		█											
Performing simulation of the multiple design approaches	Sijan		█	█										
Analyzing optional design solution	Moazzul & Jawad				█									
Selecting optimal design solution	Sijan & Jawad				█									
Selecting appropriate tools for designing	Laila, Liya					█								
Research for information, skills and materials	Laila, Liya				█	█								
Implementing the gained knowledge in the simulation	Jawad						█	█						
Evaluating and submitting the simulation report	Moazzul								█					
Project progress presentation	Everyone									█				
Identifying ethical issues	Liya							█	█					
Communication with the stakeholders	Laila									█				
Writing note, journal and preparing for the final report	Everyone										█	█		
Preparation for the final presentation	Everyone												█	█
The final presentation	Everyone													█

Fig: 19 Project plan EEE-400D

EEE400C:

Task Name	Responsibility	Week-01	Week-02	Week-03	Week-04	Week-05	Week-06	Week-07	Week-08	Week-09	Week-10	Week-11	Week-12	Week-13	Week-14
		DL and ML training	Moazzul	█	█										
Testing and Evolution	Jawad			█	█										
Adjustment	Sijan				█	█									
Data Collection	Liya					█	█								
Data Analysis	Laila						█	█	█	█					
Result Analysis	Jawad & Siyan						█	█	█	█					
Documentation	Moazzul									█	█				
Preparing draft report	Liya & Laila										█	█			
Preparing for Project Presentation	Everyone												█	█	█
Project Final Report	Everyone													█	█

Fig: 20 Project plan EEE-400C

Work duration of EEE-400P

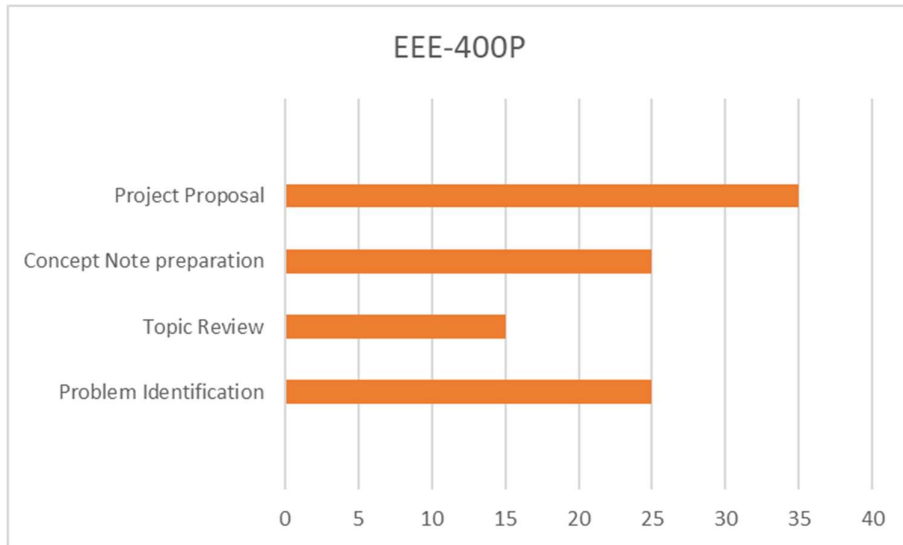

Fig: 21 Work duration of EEE-400P

Our project proposal took 10 days to complete and Concept Note preparation took a little bit more around 14 days, nonetheless we took less time on topic review and finalization. Category of problem identification took almost 34 days to complete because we did deep research and hard effort to complete the task.

Work duration of EEE-400D

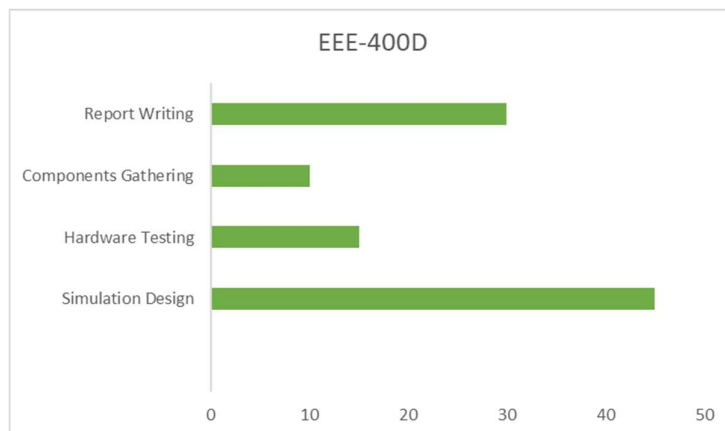

Fig: 22 Work duration of EEE-400D

In order to complete our project successfully, we worked for 25 days on hardware testing. Simulation Design, sensors, and hardware setup took approximately the same amount of time. Due to various unavailability issues, we spent the majority of our effort gathering the algorithmic components and 26 days developing them.

Work duration of EEE-400C

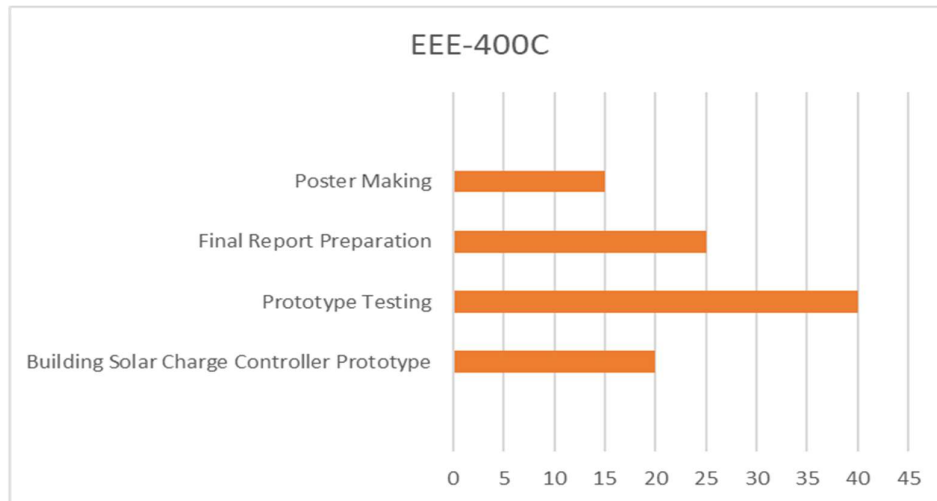

Fig: 23 Work duration of EEE-400C

We present our prototype in 400 C. We built up our prototype and tested it in various ways for 22 days in various weather conditions. It took 40 days to complete our project in accordance with the guidelines and IEEE format, and the majority of our effort was focused here. We also make poster and report accordingly.

7.3 Evaluate project progress

In May 2022, we began working on our project in accordance with our requirements. We completed every task in stages which is shown in Table-14. At the very beginning we faced a crisis because Our ATC panel got changed. But after Selecting our ATC panel we Followed the guidance of our esteemed ATC, we formed groups and selected this project topic from a variety of research areas. We wanted to work on a project that would benefit both people and the environment simultaneously, which is unpopular in the context of our nation. We have chosen to create a solar charge controller which can help people by giving them a long battery life along with better efficiency. Then, in order to obtain accurate information and gain a sense of the process, we began reading various papers, articles, and journals linked to our subject.

For each semester, we have created a work schedule. We evenly distributed our work among the team members and kept the logbook updated. We got to work on our project by adhering to the project plan. We had to complete our homework and other assignments both online and in University. Our regular weekly internet meetings continued. Our assignment for the first semester of the FYDP was to create the project plans. As a result, we talked about the project's design, methods, specifications, and budget. Additionally, we highlighted the sustainability, legal, and risk considerations. We began the simulation portion of our project during the following semester (400D). Here, we also provide a brief description of the other alternative solutions to our project's problems, along with a simulation of each one, and we explain why we chose ours. Due to high inflation rate the costs of most components increase rapidly and we also need to adjust the budget. Therefore, we demonstrated the significance of why and how our proposal would benefit both people and the environment along with economically. Finally, in the last semester of our project, we put the device into use and completed our monitoring successfully. Before the semester began, we began developing the hardware and software components. Then, within the first two weeks of the semester, we completed the hardware setup by assembling numerous components, including sensors, motors, and air controllers. Then we began gathering data by testing in several weather conditions. We contrasted the outcome of the sample data with the data under ideal conditions. We can determine our charge controller efficiency in this way.

Table:14 Project plan evaluation

Chapter	Task Title	Task Owners	Start Date	End Date	Duration	PCT OF Task Complete
Chapter No	Project Report Writing					
1	Introduction	Zawad	30/5/2022	20/5/2022	20	100%
2	Project Design Approach	Moazzul & Sijan	20/5/2022	10/6/2022	30	100%
3	Use of modern engineering and IT tools	Moazzul	25/5/2022	30/6/2022	35	100%
4	Optimization of Multiple Design and Finding the Optimal Solution	Sijan	15/8/2022	12/9/2022	28	100%

5	Completion of Final Design and Validation	Moazzul & Sijan	16/8/2022	20/9/2022	35	100%
6	Impact analysis and Project sustainability	Laila	25/8/2022	25/9/2022	30	100%
7	Engineering Project Management	Liya	30/9/2022	25/10/2022	25	100%
8.	Economical Analysis	Laila & Zawad	7/12/2022	5/12/2022	25	100%
9	Ethics and professional Responsibility	Liya & Moazzul	20/10/2022	19/11/2022	30	100%
10	Conclusion and Future Work	Zawad & Sijan	28/01/2023	1/03/2023	32	100%
11	Identification of Complex Engineering problems and Activities	Laila & Liya	1/04/2023	28/04/2023	28	100%

7.4 Conclusion

An engineering project should be effectively completed by adhering to the aforementioned processes and timetables. The project could fail if this is not done. Effective collaboration, thorough planning, communication, and research are all advantages for an engineering project. Here, we made an effort to follow them properly in our project. Without efficient project management, we struggle to make a work schedule, efficiently manage our time, and manage our finances. Consequently, thorough planning and monitoring are necessary for an engineering project.

Chapter 8: Economical Analysis. [CO12]

8.1 Introduction

The goal of economic analysis of projects is to look at and contrast various investment possibilities and make investment decisions from the perspective of the projects' economic returns. Better resource allocation makes it possible for investments to benefit the national economy as a whole as well as the local or regional economies. Economic analysis computes the financial ratio of all project expenditures to all benefits and also aids in deciding whether a project is worthwhile. Additionally, it can enable comparisons of interventions that are very different from one another in terms of their scope, cost, and duration of use. However, it necessitates a lot of significant monetary assumptions on all of the benefits.

8.2 Economic analysis

Economic analysis is a crucial component for power detection and voltage control systems in terms of tracking maximum power in any weather condition. This voltage control system will lessen the time of charging of the batteries and will extend the lifespan of the batteries as well which will help people to save money in the process. It will also lessen the environmental damage by using more renewable energy than non-renewable energy. As people depend on nature, it is our responsibility as humans to preserve the environment. In other words, due to a number of factors, such as low consumer density and accessibility, a significant section of Bangladesh's people who live in off-grid areas do not have enough access to electricity. They are forced to use highly polluting Kerosene oil and diesel generators for illumination, and they cook with biomass, wood, cow dung, and agricultural residue, which not only causes indoor pollution but also causes deforestation, soil erosion, and floods owing to resource exploitation. For this people have to face drastic loss both financially and environmentally. Again, the price of fossil fuel in our country is increasing rapidly day by day. For this reason, most of the people specially who live in remote areas are not capable of getting and purchasing enough electricity for them. We can therefore learn how much beneficial and affordable a solar charge controller through this research effort of ours and, at the same time, we may make it useful for human use. Our project will benefit those who don't always have the money to purchase electricity from non-renewable energy particularly in off grid areas and remote areas. Our economic analysis needs to be presented in a way that the average person, who may not be aware of the value of getting proper electricity, can appreciate the relevance of a system for detecting maximum power and charging the batteries in short time. Costs and benefits are a part of economic analysis, as we all know. Therefore, our objective is to develop the project and carry out the survey so that individuals may benefit the most from it at the lowest possible expense. However, we cannot use inexpensive tools but may not last for a long time or are inefficient. However, we can fall short of ensuring economic sustainability. Before utilizing or purchasing a product, we must ensure its high caliber by testing it. Every component, including charge controller, photovoltaic panel, battery and sensors needs routine maintenance. Before it results

in harm, we can determine whether a component is functioning properly or not and adjust or fix it. Additionally, it will improve the project's long-term viability.

8.3 Cost benefit analysis

Table 15: Budget Prototype

Sl.	Name of component	Quantity	Per price (Tk)	Total (Tk)
1.	Arduino nano	1	500	500
2.	20×4 LCD display	1	350	350
3.	ACS712 Current Sensor	1	150	150
4.	IR2104 IC	1	120	120
5.	MOSFET IRFZ44	4	50	200
6.	Transistor 2N2222A	1	10	10
7.	Push button switch	2	5	10
8.	Resistor (100K)	1	2	2
9.	Resistor (20K)	2	2	4
10.	Resistor (470K)	1	2	2
11.	Resistor (10K)	3	2	6
12.	Resistor (1K)	1	2	2
13.	Resistor (220 ohm)	6	2	12
14.	Capacitor (220uF)	1	5	5
15.	Capacitor (10uF)	2	5	10

16.	Capacitor (0.1uF)	6	5	30
17.	Red LED	1	2	2
18.	Green LED	1	2	2
19.	Blue LED	1	2	2
20.	Solar Panel (12V/24V/36V)	1	1000	1000
21.	Lead Acid Battery (12V)	1	1200	1200
22.	DC Jack	1	10	10
23.	PCB Board	1	1000	1000
				Total =4644 Tk

Table 16 : Cost Analysis (Prototype)

Design approach	Functionality	Component	Cost (BD tk)	Total cost (BD tk)
Pulse width modulation	<ul style="list-style-type: none"> ● Controlling Unit ● Storage unit ● Sensor unit ● Converting unit 	Arduino LCD Battery 12v Regulator PCB	500 Tk 500 Tk 1100 Tk 20 Tk 1000 Tk	3120 Tk
Maximum Power Point Tracker	<ul style="list-style-type: none"> ● Controlling Unit ● Storage unit ● Sensor unit ● Converting unit 	Arduino LCD Battery 12v Current sensor Voltage sensor Regulator PCB	500 Tk 500 Tk 1100 Tk 150 Tk 280 Tk 20 Tk 1000 Tk	3550 Tk

Here most of the components in two methods are quite similar but the charging time and efficiency is different among them.

There are so many charge controllers available in the market. The market for solar charge controllers was worth USD 1.4 billion in 2017, according to estimates. It is anticipated to increase at a CAGR of 8% between 2018 and 2028. In terms of geographical markets, East Asia and Europe will continue to dominate. Due to the expanding industrial sector, solar charge controllers are predicted to become more and more necessary in rising economies like China, India, Brazil and Asian countries in order to improve manufactures of the batteries and to continue substantial demand. The demand for solar charge controllers increased dramatically worldwide in 2022 as a result of factors like limited electricity supply in some areas, frequent power outages, and the rapidly rising cost of non-renewable energy. African, Asian, and Latin American nations have seen an increase in this tendency. Rising awareness and the creation of subsidiaries for the building of off-grid solar panel systems would greatly enhance the global market for solar charge controllers. The solar charge controller market has been driven by the increasing number of products manufactured in the United States, China, and Japan. One of the most important control strategies for maximizing electricity from solar panels is the use of charge controllers. The demand for solar charge controllers is also expected to increase in the near future due to the use of this product as a vital component to produce more electricity within a short time in any weather condition. In order to protect the batteries from damage caused by overcharging, low voltage, or reverse current, these controllers are constantly monitoring the voltage coming from the solar array and the batteries. Rising industrial power needs, massive population growth, and the building of countless new homes in emerging markets are all factors fueling the industry's rapid rise. Despite the fact that these controllers are intended to provide maximum power, it is advised to choose one that won't be hugely expensive. According to a survey, more than 20 million charge controllers will be entered into the market in 2020 which are very expensive for the general public to use. This will be a great threat for us economically. Bangladesh's economy is currently not doing well. An expanded budget might not function correctly in this situation. We don't want to spend more money in the future to get minimum electricity. Consciously spending money for basic needs is important, but given the state of the economy, purchasing new charge controllers very often would be pricey for us. To manage this, maximum power detection and voltage control systems can be a fantastic solution. Both the general public and industries where the need of electricity is must will benefit from it. We already discussed numerous methods for improving the efficiency of solar charge controllers. Our other two methods required manual setup and were occasionally more difficult. In this circumstance, an enlarged budget may not work properly. We don't want to pay more money in the future in order to receive the cheapest power. However, those strategies are not economically viable for our nation in terms of both efficiency and cost. Market comparison of our product and competitive products is given in Table-17

Table: 17 Market Analysis

Design approach	Functionality	Charging Time (From 11V-12V)	Total cost (BD Tk)
Pulse width modulation	<ul style="list-style-type: none"> ● Controlling Unit ● Storage unit ● Sensor unit ● Converting unit 	150 seconds	16500 Tk
Maximum Power Point Tracker	<ul style="list-style-type: none"> ● Controlling Unit ● Storage unit ● Sensor unit ● Converting unit 	90 seconds	18000 tk

Solar charge controllers make up a sizable component of this market because they provide real-time data that enables the voltage level of the batteries and photovoltaic arrays in any weather condition. They provide convenience and efficiency by preventing overcharging of the batteries. The market for charge controllers, which is anticipated to be worth USD 50 billion by 2030, presents a large opportunity for industries and other businesses. The battery may be charged up to 30% faster per day using one 15 A/200 W solar charge controller. The solar charge controller industry is segmented based on current capacity and end user. The charge controller market is segmented into maximum power point tracking (MPPT) controllers, pulse width modulation (PWM) controllers, and simpler 1 or 2 stage controllers. Current capacity categorizes it into three groups: below 20A, 20A to 40A, and 40A and beyond. Based on the end users, it is divided into three sections: solar home stations, commercial & utility, and industrial. The market is broken down by geography, including the Americas, Europe, Asia, and the Middle East and Africa. The more efficient controller used to cost between USD \$150 and USD \$200 in Max, but now sells for between USD \$300 and USD \$500 in China. Charge controllers are used primarily in these devices to avoid overcharging, regulate reverse current, and maintain a constant voltage. Low availability of electricity in certain regions, frequent power backups and the rapidly increasing price of non-renewable energy had an effect on and hastened the market's expansion.

MPPT solar charge controllers in photovoltaic systems will cost around 18000 taka per unit. If we compare it, it's near competitive. For instance, Schneider Electric introduced the Context MPPT 100 high-power solar charge controllers in October 2020. According to the manufacturer, this controller increases charging power by 25% over the MPPT 80. Because the product is intended to operate at 600 V, including the temperature adjustment factor, balance-of-system expenses are reduced. This strategy enhanced the product portfolio of the company. If we want to sell this in the market, we have to develop the quality and it will cost around 18000 taka per unit with all maintenance costs. In this situation, the MPPT solar charge controller is without a doubt the finest choice. In 2021, maximum power point tracking (MPPT) solar charge controllers had a 43.3% market share; this category is expected to maintain its dominant position throughout the forecast period. The widespread installation of solar panels as a means of generating electricity explains this trend. Furthermore, MPPT solar charge controllers optimize the power produced by solar panels and outperform PWM solar charge controllers in terms of efficiency and performance, factors that are expected to drive the market's growth during the projected year. While the MPPT charge controller is more expensive than the other two kinds of controllers, its efficiency and lifespan are much superior. However, we will receive real-time data from which we can see the state of charge mode in any weather. Our project's data count is more precise and efficient than others. It has a time counter as well because it can count the timing that the system is taking to convert the voltage from maximum to minimum or minimum to maximum. As the data will be stored in the LED, this has the benefit of allowing for constant analysis and the ability to compare charge controller's effectiveness to choose the best solution. The segment with the highest revenue share in 2021—30%—was industrial application. The market is being driven by industries' increasing awareness of the value of using charge controllers to produce maximum electricity. Due to the expanding industrial sector, use of charge controllers are becoming more and more common in developing nations like China and India. The expansion of this market is being driven by the use of charge controllers at remote areas, domestic areas and various kinds of firms. The growing awareness among users to address the overpopulation and environment pollution is another factor contributing to the segment's rise. The market for these goods is being driven by new users who are being encouraged by growing understanding of the negative impacts.

8.4 Evaluate economic and financial aspects

The market for solar charge controllers is anticipated to reach \$1.4 billion in sales in the year 2017, and it is anticipated that this market will have increased to \$3.4 billion by the year 2031, with a compound annual growth rate (CAGR) of 8% between the years 2018 and 2028. The solar charge controller regulates the amount of voltage and current that flows from the solar panels to the battery that is linked to the system in order to avoid the battery from being overcharged or discharged. Off-grid solar panel systems often make use of solar charge controllers in order to regulate the amount of power that is absorbed by batteries. The vast majority of solar charge controllers for PV applications on the market today make use of a switching series regulator in order to take care of the charging current.

A voltage and current regulator that is powered by solar energy is referred to as a solar charge controller. Bangladesh, a growing nation in South Asia, is dealing with a serious energy issue. The nation is unable to adequately meet its need for electricity. Approximately 88% of people have access to electricity, but load shedding affects 79% of those who are connected to the grid, and low voltage supply issues affect 60% of those as well. Furthermore, the generation of electricity uses fossil fuels, particularly natural gas, to the tune of 52.58%.

According to predictions, the current natural gas reserve will run out somewhere between 2020 and 2030. In this case it will become a very economic loss to depend on other countries for electricity. Also, it will ruin the industrial sector as well. If there is economic loss it is very much sure that it will end up in a financial crisis for the country. The country will become economically handicapped. To save from this environmental crisis, discovery of alternative energy sources is a requirement. In this condition it is very important to develop new sources of energy. Sun is the most available source of energy and renewable. So, developing a Solar PV system more advanced within a cheap cost is very much important for the economic growth of the country. And with this MPPT system we can use the Solar PV system more efficiently. The economic feasibility study has been completed using net present value to weigh the costs and advantages of the endeavor. Therefore, monetary values are assigned to all costs and benefits. Not counting environmental or other long-term social benefits, the financial benefits include things like savings on kerosene, lamp replacement costs, other item replacement costs (wick or mantle, chimney, hurricane), battery purchase and charging costs, generator bulb costs, bulb costs, cost of charger light, and modest income generation from longer working hours. Total cost, on the other hand, factors in not just the initial investment but also the ongoing expenses of maintaining and upgrading components like the switch, solar inverter, LED light, and charge controller.

8.5 Conclusion

We can infer from the reasoning above that this solar charge controller system reuse can reduce time of charging of the batteries and costs. Every day, new modern technologies are developed to make people's lives easier. Due to lack of employment and inability to control the voltage of any photovoltaic system in order to produce electricity, a large number of people are not getting enough electricity for their daily lives. If individuals start using controllers without the proper capacity of controlling voltages of the batteries again and again, the longevity rate of the batteries might go down. Each LED battery (12 V) costs 1100 taka in Bangladesh. If people need to change their batteries very often; they might face a financial crisis and the cost of the overall project will be increasing day by day. However, our initiative will be both financially and environmentally advantageous. It is challenging to invest significantly in the renewable sector given the state of the economy in our nation. In order to achieve maximum benefits at the lowest possible cost, we therefore endeavored to create a solution. When compared to the other two alternatives, ours offers a more efficient and effective result that may also ensure the project's sustainability. It makes our project more affordable by saving time, labor, and money.

Chapter 9: Ethics and Professional Responsibilities CO13, CO2

9.1 Introduction

The purpose of ethics is to give people moral and behavioral rules that will enable them to make moral judgments about what is right and wrong as well as actions and behaviors. Moral standards frequently exceed the minimal minimum demanded by law. The PMI (Project Management Institute) states that "ethics is about making the best choices feasible with regard to people, resources, and the environment. Project management involves a number of potential ethical pitfalls [14]. The bigger the project, the more likely it is that employees will be willing to compromise their values in order to do it on time and under budget. Ethical consideration is a key component of project management because it supports human rights, scientific integrity, and a collaboration between science and society. The safety of the research is guaranteed by these ethics. A project idea won't be supported if it violates human rights even when it is advantageous to society, according to ethics. Different ethical issues can arise depending on the circumstance. Fairness, respect, accountability, honesty, and trust are included among the ethical principles of the Code of Ethics and Professional Conduct. The respect for confidentiality, lowering the risk of harm, avoiding plagiarism, accuracy in analysis and reporting, etc. are additional facets of research ethics in addition to these. There are also other conduct guidelines that have been issued by various international organizations for particular industries. We must follow these guidelines and procedures as we conduct the research. Another option is to reject project proposals if moral standards are not upheld. Following such guidelines also ensures the sustainability of the project. Regarding our project, we must adhere to the government protocols, the IEEE code, and other guidelines.

9.2 Identify ethical issues and professional responsibility

When working on any project, ethics is one of the most important considerations. It is a set of ideals and rules that ought to guide how people conduct their affairs. An ethical assertion may be presented in the form of an expression, an image, or anything realistic on the name of a product or package, in product text, in publicity, or in reputation, among other forms. No one acts in a way that is detrimental to society, ethical considerations prove this beyond a shadow of a doubt. Furthermore, while a project is being carried out, ethical considerations can lower risk, advance positive outcomes, boost confidence, and build notoriety and victory. When it comes to the commercial production of our test setup, there are a few considerations to bear in mind.

1. Obviously, we will obtain authorization and sign a legal contract before installing our optimal system in any place.
2. We must substitute components for any equipment that is environmentally harmful when constructing the test setup.

3. We must include the correct cites and references if we want to include any statements or other content from these sources in our project.

4. We can't use any components, sensors and products which are declared as illegal by our government.

5. We shall be obligated to the particular one, thus the outcomes of what we obtain won't be shared with others.

9.3 Apply ethical issues and professional responsibility

Legal Consent: We took approval from our department for Working under Supervision. We took permission from the Lab Assistant of our department and before setting up we ensured the safety. We are attaching the form in the Appendix.

Flat Owner Consent: We also took approval from the Flat Owner for working in his premises and collecting data. We are attaching the form below also in the Appendix.

Risk Management and Contingency Plan

While planning and developing the idea of a project, we must keep in mind the possibility of risks since it can take place at any time and in any location and we do not have any control over it. First, we should list some types of risks which might occur and then analyze them, coming up with the idea of understanding the level of risk and the alternative plans. It is necessary that we all should be proactive instead of reactive.

Table: 18 Risk Management and Analysis

Risk Description	Risk Assessment	Contingency Plan	Alternate Plan	Responsible member
The project could face a capital cost overrun.	Low	Adequate contingencies have been provided. Price variation conditions need to be built into the bid document and advance procurement initiated.	To incorporate a large number of Investors.	All

<p>Implementation could be delayed, leading to cost overruns.</p>	<p>Low</p>	<p>This risk can be mitigated by including positive incentives i.e. price bonuses for early commissioning in the bidding document and plug and play solutions.</p>	<p>Govt Tax can be exempted and a notable amount of rebate can be imposed.</p>	<p>All</p>
<p>Climate change leads to insufficient solar power.</p>	<p>High</p>	<p>The solar panels were angled solar power generation yield in the mornings and afternoons. North-facing panels would benefit only in the middle of the day, which is also more likely to be interrupted by weather and climate events.</p>	<p>Continuously checking the data of weather and on the basis of the data modification will be applied on the system.</p>	<p>All</p>
<p>The solar power systems and equipment may not be operated and maintained properly.</p>	<p>Medium</p>	<p>This risk can be lowered, through a long-term capacity building program that is to be implemented right after the tender process. A long-term service agreement with a reputable international services firm will reduce the risk to a minimum level.</p>	<p>As the Module cannot Recycle so We should replace With New one</p>	<p>All</p>

Decommissioning of equipment and disposal of batteries could adversely affect the environment.	High	The project includes an environmental management plan.	To follow the policy and regulations of the Ministry of Environment, BD and signing a contract with some private organization to safe dispose of materials.	All
PCB design	Low	When we build our PCB it can burn our microcontroller and other components if we do not do it properly	If we failed to build our PCB we will construct the connection in the breadboard so that we can complete our project.	All
Landowners become concerned about the project during implementation.	Medium	We have set out a plan for consultation activities with landowners, project-affected persons, and the public at large.	To revise the contract with the Landowner and increase his profit share which will not be uneconomical for the project implementing team.	All

Safety Consideration

● PV Over Current

The controller will only allow the Maximum Battery Current rating to be exceeded while the battery is being charged. Because of this, a solar array that is too large will not produce its maximum amount of electricity.

● PV Short Circuit

The controller will halt charging if there is a PV short circuit that is switched on or a PV input that is short circuited on low power. Remove it so that regular functioning can continue. When the PV input experiences a short circuit while operating at high power, the controller may sustain damage.

● PV Reverse Polarity: The PV can be reversely connected with a controller when:

- Only the PV is connected with the controller.
- The battery is positively connected, and the open-circuit voltage of the PV is lower than 85V (This requirement is only for Tracer 26/39/5210BP).
- Controller will be damaged when the PV array has straight polarity and the actual operating power of the PV array is 1.5 times greater than the rated charge power.

● **Battery Reverse Polarity:** When the PV is not connecting or connecting reversed, fully protected against the battery reverse polarity, correct the wire connection to resume normal operation. The controller will be damaged when the PV connection is correct and the battery connection is reversed.

● **Battery Over Voltage:** When the battery voltage reaches the set point of Over Voltage Disconnect Voltage, the controller will stop charging the battery to protect the battery from being overcharged to break down.

● **Battery Over Discharge:** When the battery voltage reaches the set point of Low Voltage Disconnect Voltage, the controller will stop discharging the battery to protect the battery from being over-discharged to break down.

● **Battery Overheating:** The controller detects the environment temperature through the external temperature sensor. If the environment temperature exceeds 65 C, the controller will automatically start the overheating protection to stop working, and recover below 55 oC.

- **Lithium battery Low Temperature:** The temperature sensor is less than the low-temperature value, Lithium battery stops charging/discharging. It is higher than the low-temperature value, Lithium battery starts charging/discharging.
- **Load Overload:** If the load current exceeds the maximum load current rating 1.05 times, the controller will disconnect the load. Overloading must be cleared up by reducing the load.

9.4 Conclusion

Research and initiatives are guided by a set of principles or ideas known as ethical concerns or ethics. Such principles must be upheld for a project to succeed and to win the public's support. Respecting those guidelines is part of being accountable for your professional conduct. In this project, we tried to address these ethical issues and uphold them as we carried out our research. Before applying prospective factors to our project, we first group those that might be relevant. Others were not applied, even though some of them were dropped from the list since they didn't apply to our research or project in actual tests.

Chapter 10: Conclusion and Future Work

10.1 Project summary/Conclusion

Our project is the design of a charge controller for a solar pv system. From three different designs we chose Maximum Power Point Tracking (MPPT) solar charge controller. Modern solar charge controllers additionally make use of state-of-the-art electronics and power-saving techniques to further cut down on energy waste and improve system effectiveness. As solar power technology develops, researchers and developers are always researching and developing solar charge controller performance and sustainability. In this charge controller we used Arduino nano, mosfet, voltage regulator, current sensor, battery. When the solar PV system is fully charged green led will blink. When charge will need yellow led will blink and when there is no charge red led will blink. There are two moods in this charge controller. Bulk mood and float mood. We measured that when the bulk mood is on charge controller charged very fast but in float mood charge controller charged slowly. We made the charge controller cost efficient, essential and low-cost maximum output.

10.2 Future work

It is commonly known that a variety of technologies are used to produce electricity, including thermal power plants (using fuels like coal, oil, and nuclear energy) and hydroelectric facilities, however these methods consume non-renewable resources and are bad for both the environment and people. There are numerous additional charge controller kinds, such as PWM and others, but because of their poor efficiency, users cannot fully utilize them. Therefore, more affordable and efficient MPPT algorithms must be created in order to achieve better efficiency. Given the size of the world's population and the demand for electricity, it is essential to use solar energy and to wring more power from it; MPPT is one method to do this effectively. As mentioned, the parasitic capacitance method outperforms the P&O and Increment conduction methods in terms of power output. So due to the growing population, renewable energy sources are required. As a result, solar energy is becoming more and more popular. It is preferable to utilize the MPPT algorithm to extract the most power, so it is necessary to build several MPPT algorithm types to efficiently extract the most power possible from solar radiation. Comparisons are made based on the pros and cons, voltage ripple, average power obtained, and time response. The "MPPT Solar Charge Controller Market Report 2023 - Future Opportunities, Latest Trends, In-depth Analysis, and Forecast to 2029" research report provides strategic insights into the MPPT Solar Charge Controller market along with market size (volume - million units and revenue - US\$ billion) and projections for the years 2023 to 2029. The aforementioned research study examines various market segments in-depth in terms of type, application, and various topographies.

The growing usage of renewable energy sources is driving the demand for solar charge controllers. The charge controller is crucial to the safety of the battery system and, consequently, the power supply system.

Chapter 11: Identification of Complex Engineering Problems and Activities

11.1: Identify the attribute of complex engineering problem (EP)

There are a few structures for difficult building problems. We're trying to explain them below

- **Depth of knowledge required:** We need accurate knowledge of the important field in order to develop a suitable building extension. Without reliable information, we cannot think deeply about a project. Consequently, to some extent, having accurate information about practically every particular issue is required.
- **Range of conflicting requirements:** This indicates that there may be some conflicting issues when we start looking into something or building something. Our motivation should be to resolve those problems and provide a solution in such a way that the extent will be convincing and safe. Our goal will be to understand these conflicting issues and offer a secure solution while doing endeavors that may involve them. These issues might be technical, legal, natural, etc.
- **Depth of analysis required:** It is yet another essential perspective on challenging engineering issues. An adequate in-depth analysis is required to develop a fruitful extent. Without it, a lot of things will happen in the future that we might not be able to comprehend. As a result, the project won't be of any use.
- **Familiarity of issues:** It means that when an unused extension is planned to be implemented or proposed, the average person won't be familiar with it. Additionally, this problem could also relate to everyday problems, and we would need to update or modernize the previous solutions.
- **Extent of applicable codes:** There could be a number of engineering protocol-related problems while creating a complicated engineering project. To carry out the project, we must adhere to international regulations and standards. The project will fail otherwise.
- **Extent of stakeholder involvement and needs:** Approximate level of collaboration among partners and needs for discussions upon partner request. It means that we must make sure that the intended audience of our venture benefits from the venture arrangement.
- **Interdependence:** Interdependence suggests that one problem is related to another, hence the problem needs to be resolved in order to bring about the ideal solution. Only a few of the aforementioned traits are applied to our fullest extent.

They are shown in the table below:

Attributes of Complex Engineering Problems (EP)

Table 19: Attributes of Complex Engineering Problems (EP)

	Attributes	Put tick (√) as appropriate	Justification
P1	Depth of knowledge required	√	In depth knowledge about algorithms, hardware systems, software, and the functionality of components is required for the practical implementation of our project.
P2	Range of conflicting requirements		
P3	Depth of analysis required	√	Formulated 3 suitable models and by a deep analysis through comparing and abstract thinking reached the optimal circuit design.
P4	Familiarity of issues	√	Familiarity is seen in developed countries and also in our country.
P5	Extent of applicable codes		
P6	Extent of stakeholder involvement and needs		
P7	Interdependence		

11.2: Provide reasoning how the project address selected attribute (EP)

Our scope has met some of the aforementioned requirements. We are still defining such characteristics. We had to undertake some pre-research in order to conduct our course. Thus, we prepared to choose the best configuration, which offers the most advantages, at least incurs costs. We completed every step of the preparation. We recently read a few earlier publications that were connected to the topic of our inquiry at the beginning of this project, which helped

us to become motivated and think through our work. From this, we also gather knowledge about relevant fields that helps us make decisions about how to manage the project. Then, during the equipment phase, prior to assembling the sensors, battery, and we went through various types of inquiries regarding the selection of the device and the method of gathering. Each sensor has been tested by our team to identify whether or not they are feasible. We considered cutting edge innovation when selecting our device and its components. None of the components that are out-of-sale and have less effectiveness were used by us. We went through a point-by-point analysis of every action in our extension. We briefly listed the advantages and disadvantages of each layout while choosing from the several designs. which was a deciding factor in our decision to select the top candidate out of them. We have examined the sensor data inside the computer program area. Briefly in order to provide a clear yield regarding the efficiency of cover. We described every detail of our information investigation that could affect the outcome of our probe. As a result, the Profundity of examination needed for our venture has been successfully established. While conducting various plan analyses, the quality of conflicting necessities has come into focus. We had settled on three options for our observing framework. Then examine each of them to see which is more successfully and effectively satiating our desired need. Each one of them has a few good aspects and a few bad aspects. We narrowed them down and chose the one that will best enable us to achieve the desired yield.

11.3 Identify the attribute of complex engineering activities (EA)

The properties of complex building activities (EA) are portrayed below:

- **Range of resources:** The package of assets includes elements required for successful extended execution. The resources category includes people, equipment, money, time, knowledge, and anything else needed from the project planning to the project delivery phases.
- **Level of interaction:** It includes all forms of interpersonal connection and communication with those involved in broad topics, including professionals, engineers, couples, and even group communication.
- **Innovation:** Development is a different perspective on a construction project because it allows us to create something out of nothing that will be useful to others. As a result, the solution needed to benefit the targeted group should provide a suitable degree of productivity.
- **Consequences for society and the environment:** A complicated design scope must produce a few outcomes that are relevant to the environment and society. It is discussed in this property. We had to learn about them and understand them in every way imaginable.

● **Familiarity:** When conducting research on a topic or undertaking a project, a number of items that are unfamiliar to us may surface, making the task challenging to complete. In this instance, we were able to resolve them through reputable research and cooperation.

Three of these characteristics are associated in our range and are shown in the box below:

Attributes of Complex Engineering Activities (EA)

Table 20: Attribute of complex engineering activities (EA)

	Attributes	Put tick (√) as appropriate	Justification
A1	Range of resource	√	Our project met a diverse range of resources. Like, so many literature reviews for gathering knowledge on information and technology, worked according to our plan, we had a discussion on confirming the components and for budget selection, etc.
A2	Level of interaction		
A3	Innovation		
A4	Consequences for society and the environment	√	Will reduce environmental burden as well as cost-efficient devices can reduce economic burden.
A5	Familiarity	√	Familiar/common for developed countries but new and additional features are present for our country

11.4 Provide reasoning how the project address selected attribute (EA)

Our scope required a lot of resources at every stage; from planning to execution, we had to use various types of resources based on the project's requirements. Components that are necessary for a successful extended execution called extended assets. They include individuals, everything that is needed, from the planning stages of the project to the extended delivery phases, including tools, money, time, and information. We have read portions of articles, journals, and diaries dating back to the first semester of our past year's plan that are significant

to our level. These make up a portion of assets as well. At that time, we used a variety of computer programs, including Arduino programming. Finally, we built the sensors and PV and set up the entire device ourselves for hardware implementation. We had to follow a similar process for budget planning and work. That was an excessive use of resources. We discussed the matter with our ATC to get his opinion, looked into it internally, and shared our opinions, all of which helped us. To promote options and produce a successful endeavor. So, it can be said that a variety of resources were successfully used to complete the entire project. When conducting venture exercises, the basic venture management processes, such as planning, organizing, carrying out, checking, and controlling, as well as closing, can interact with one another through the use of process intelligence. Each member of our group interacted with the others and exchanged ideas and considerations. We diligently completed our weekly meetings and continued our weekly get-togethers. We respect each other's viewpoints and in order to receive advice from our respected ATC, we also reviewed them among ourselves. A successful venture requires a high level of contact. We all contributed our ideas, from choosing the project topics to carrying out our project. and after deliberation, we decided on the final options. Thus, we have successfully completed our project.

References

- [1] T. Sudhakar Babu, K. Sangeetha, and N. Rajasekar, "Voltage band based improved particle swarm optimization technique for maximum power point tracking in Solar Photovoltaic System," *Journal of Renewable and Sustainable Energy*, vol. 8, no. 1, p. 013106, 2016.
- [2] J. P. Ram, T. S. Babu, and N. Rajasekar, "A comprehensive review on solar PV maximum power point tracking techniques," *Renewable and Sustainable Energy Reviews*, vol. 67, pp. 826–847, 2017.
- [3] M. A. ., "A cost effective solar charge controller," *International Journal of Research in Engineering and Technology*, vol. 04, no. 03, pp. 314–319, 2015.
- [4] F. Sani, H. N. Yahya, M. Momoh, I. G. Saidu, and D. O. Akpootu, "Design and construction of microcontroller based charge Controller for Photovoltaic Application," *IOSR Journal of Electrical and Electronics Engineering*, vol. 9, no. 1, pp. 92–97, 2014.
- [5] S. A. Khan, R. Rahman, and A. Azad, "Solar Home System Components Qualification testing procedure and its effect in Bangladesh perspective," *2012 IEEE Global Humanitarian Technology Conference*, 2012.
- [6] K. S. Jyothi, "Battery charging from solar using Buck converter with MPPT," *International Journal for Research in Applied Science and Engineering Technology*, vol. 9, no. VI, pp. 3490–3493, 2021.
- [7] A. Anurag, S. Bal, S. Sourav, and M. Nanda, "A review of maximum power-point tracking techniques for photovoltaic systems," *International Journal of Sustainable Energy*, vol. 35, no. 5, pp. 478–501, 2014.
- [8] Fianti, A. Y. Perdana, B. Astuti, and I. Akhlis, "Analysis of PWM- and MPPT-solar charge controller efficiency by Simulation," *Journal of Physics: Conference Series*, vol. 1918, no. 2, p. 022004, 2021.
- [9] . M. P. ., "Design and development of advanced microcontroller based Solar Battery Charger and solar tracking system," *International Journal of Research in Engineering and Technology*, vol. 03, no. 15, pp. 35–41, 2014.
- [10] Chikate, B. V., Sadawarte, Y., & Sewagram, B. D. C. O. E. (2015). The factors affecting the performance of solar cells. *International journal of computer applications*, 1(1), 0975-8887
- [11] X. H. Nguyen and M. P. Nguyen, "Mathematical Modeling of Photovoltaic Cell/module/arrays with tags in MATLAB/Simulink," *Environmental Systems Research*, vol. 4, no. 1, 2015.

- [12] A. Victor, D. K. Mahato, A. Pundir, and G. J. Saxena, "Design, simulation and comparative analysis of different types of solar charge controllers for optimized efficiency," *2019 Women Institute of Technology Conference on Electrical and Computer Engineering (WITCON ECE)*, 2019.
- [13] Y. Shang, L. Wang, M. Zhang, and H. Wang, "Construction planning and practice of University Virtual Simulation Experimental Teaching Center under the background of New Liberal Arts," *OALib*, vol. 09, no. 08, pp. 1–11, 2022.
- [14] ["Comparison of the advantages and disadvantages of several mainstream electronic circuit simulation software" Available at <https://blog.actorsfit.com/a?ID=01000-202df8c1-9544-43dd-bdc2-844e64c1d201>]
- [15] "MAXIMUM POWER POINT TRACKING- EFFICIENCY AND ITS FUTURE SCOPE Rohit Jain*, Aadil, Richa Khera, Rajat Department of Electrical and Electronics Engineering, Manav Rachna International University, Faridabad, Haryana, INDIA."
- [16] M. Hasan and H. Serra Altinoluk, "Current and future prospective for battery controllers of solar PV Integrated Battery Energy Storage Systems," *Frontiers in Energy Research*, vol. 11, 2023.
- [17] B. Wichert and W. Lawrance, "Predictive control of photovoltaic-diesel hybrid energy systems," *Sixteenth European Photovoltaic Solar Energy Conference*, pp. 2683–2686, 2020.
- [18] I. K. Abdul-Razzaq, M. M. Fahim Sakr, and Y. G. Rashid, "Comparison of PV panels MPPT techniques applied to solar water pumping system," *International Journal of Power Electronics and Drive Systems (IJPEDS)*, vol. 12, no. 3, p. 1813, 2021.
- [19] M. J. Abed and A. Mhalla, "Adequate reliability assessment of solar PV generator based DC Chopper," *2021 12th International Renewable Energy Congress (IREC)*, 2021.
- [20] N. H. A. Rahman, A. M. Omar, E. H. Mat Saat, N. I. Ilham, M. Z. Hussin, and Y. Y., "Design and development of Three stages maximum power tracking solar charge controller," *Indonesian Journal of Electrical Engineering and Computer Science*, vol. 18, no. 3, p. 1270, 2020.
- [21] B. Aboagye, S. Gyamfi, E. A. Ofosu, and S. Djordjevic, "Investigation into the impacts of design, installation, operation and maintenance issues on performance and degradation of installed solar photovoltaic (PV) systems," *Energy for Sustainable Development*, vol. 66, pp. 165–176, 2022.
- [22] H. Abobakr, A. Diab, Y. B. Hassan, and A. Khalaf, "Performance analysis of a small-scale grid-connected photovoltaic system: A real case study in Egypt," *Journal of Advanced Engineering Trends*, vol. 40, no. 1, pp. 79–96, 2021.

- [23] Y. E. Abu Eldahab, N. H. Saad, and A. Zekry, "Enhancing the design of battery charging controllers for photovoltaic systems," *Renewable and Sustainable Energy Reviews*, vol. 58, pp. 646–655, 2016.
- [24] M. Ahmad, A. Numan, and D. Mahmood, "A comparative study of perturb and observe (P&O) and Incremental Conductance (INC) PV MPPT techniques at different radiation and temperature conditions," *Engineering and Technology Journal*, vol. 40, no. 2, pp. 376–385, 2022.
- [25] E. M. Ahmed, H. Norouzi, S. Alkhalaf, Z. M. Ali, S. Dadfar, and N. Furukawa, "Enhancement of MPPT controller in PV-bes system using incremental conductance along with hybrid crow-pattern search approach based ANFIS under different environmental conditions," *Sustainable Energy Technologies and Assessments*, vol. 50, p. 101812, 2022.
- [26] S. M. Ahsan, H. A. Khan, N.-ul Hassan, S. M. Arif, and T.-T. Lie, "Optimized Power Dispatch for solar photovoltaic-storage system with multiple buildings in bilateral contracts," *Applied Energy*, vol. 273, p. 115253, 2020.
- [27] H. A. Al Kader Hammoud and A. M. Bazzi, "Model-based MPPT with Corrective Ripple Correlation Control," *2020 IEEE Power and Energy Conference at Illinois (PECI)*, 2020.
- [28] Alam, M.S. and Gao, D.W. (2007) "Modeling and analysis of a wind/PV/fuel cell hybrid power system in homer," *2007 2nd IEEE Conference on Industrial Electronics and Applications* [Preprint]. Available at: <https://doi.org/10.1109/iciea.2007.4318677>.
- [29] Keerthana, T., Shankar, S. and Ramprabhakar, J. (2017) "Continuous tracking of maximum power point of PV array with Controller," *2017 International Conference On Smart Technologies For Smart Nation (SmartTechCon)* [Preprint]. Available at: <https://doi.org/10.1109/smarttechcon.2017.8358337>.
- [30] Khatib, T. *et al.* (2011) "Optimal sizing of building integrated hybrid PV/diesel generator system for zero load rejection for Malaysia," *Energy and Buildings*, 43(12), pp. 3430–3435. Available at: <https://doi.org/10.1016/j.enbuild.2011.09.008>.

Appendix

Logbook

Table- Team Logbook EEE-400P

Table 21: Team logbook -400P

Date/Time/Place	Attendee	Summary of Meeting Minutes	Responsible	Comment by ATC
16.06.2022	All members	Discussion about project Topic	All members	
19.06.2022	All members	Discussion on everyone's gathered idea initial choosing of topics.	All members	
23.06.2022	ATC Meeting	Proposed the initial ideas	All members	Suggested to gather more information about initial ideas.
27.06.2022	Jawad, Moazzul, Liya	Discussion on smart agriculture monitoring project.	Jawad, Moazzul, Liya	
01.07.2022	Sijan, Laila	Discussion on proposed ideas.	Sijan, Laila	
05.07.2022	Jawad, Moazzul	Preparation of slides for presentation 1	Jawad, Moazzul	
	<u>ATC Panel Changed</u>			
18.07.2022	ATC Meeting	Meeting with new ATC and Discussion on new topic	All members	Suggested a new topic on solar system
20.07.2022	Laila, Sijan, Liya	Research on new topic and selection of Objectives	Laila, Sijan, Liya	
26.07.2022	ATC Meeting	Review on objectives	All members	Directed about choosing specifications and requirements
31.07.2022	Jawad, Moazzul, Sijan	Preparation of Concept Note	Jawad, Moazzul, Sijan	
02.08.2022	ATC Meeting	Review on Concept Note	All members	Suggested some changes

				on Concept Note
03.08.2022	Laila, Sijan, Liya	Analyzing specifications and component level flowchart	Laila, Sijan, Liya	
07.08.2022	Jawad, Moazzul,	Analyzing budget , components and project plan	Jawad, Moazzul,	
09.08.2022	ATC Meeting	No one		
10.08.2022	Liya,Sijan, Jawad,	Discussion on project proposal	Liya,Sijan, Zawad,	
14.08.2022	Moazzul, Laila	Preparing report	Moazzul,Laila	
16.08.2022	ATC Meeting	Review on project proposal report	All members	Suggested some new changes on specifications and requirements
18.08.2022	All members	Discussion on specifications and requirements	All members	
21.08.2022	Moazzul, Jawad, Laila	Preparing Report on Project Proposal	Moazzul, Jawad, Laila	
23.08.2022	ATC Meeting	Review on report	All members	Suggestion for changes on load calculation
25.08.2022	Sijan, Liya	Discussion on new load calculation and preparing report	Sijan, Liya	
28.08.2022	All members	Report preparation and dividing rest of the works for final presentation and making slides	All members	
30.08.2022	ATC Meeting	Review on Report for Final Presentation	All members	Gave instruction about Final Project Report

Table- Team Logbook EEE-400D

Table 22: Team logbook -400D

Date/Time/Place	Attendee	Summary of Meeting Minutes	Responsible	Comment by ATC
03/10/22	ATC Meeting	Discussion about the Simulation of multiple designs that we choose.	ALL	Find more idea
09/10/22	1.Jawad 2.Moazzul 3.Laila 4.Liya 5.Sijan	Simulation of design1 and 2	ALL	.
17/10/22	ATC Meeting	Simulation showed	ALL	Suggested to change the approach
20/10/22	1.Jawad 2.Moazzul 3.Laila 4.Sijan 5.Liya	Simulation of all design approaches with individual sensors	Design 1- Jawad, Moazzul Design2,3- Laila, Liya, Sijan All done in Proteus	
25/10/22	1.Jawad 2.Moazzul 3.Laila 4.Liya 5.Sijan	Taking preparation of progress presentation	ALL	
31/10/22	ATC meeting	Showed Simulation of all designs	Moazzul, Jawad, Sijan	Suggested to done simulation in different Software.
03/11/22	1.Jawad 2.Moazzul 3.Laila 4.Liya 5.Sijan	Starting design in new Software tool(MATLAB)	Liya, Laila	

14/11/22	ATC Meeting	Showed new simulations In MATLAB simulink	Jawad, Sijan	Suggested some changes.
17/11/22	1.Jawad 2.Moazzul 3.Laila 4.Liya 5.Sijan	Discussed about the new Changes comment by ATC	ALL	
20/11/22	1.Jawad 2.Moazzul 3.Laila 4.Liya 5.Sijan	Making final report	ALL	
24/11/22				
28/11/22	ATC meeting	Showed final Simulation	Moazzul, Laila, Liya	Approval of simulation
01/12/22	1.Jawad 2.Moazzul 3.Laila 4.Liya 5.Sijan	Making final report	ALL	
07/12/22	1.Jawad 2.Moazzul 3.Laila 4.Liya 5.Sijan	Made final presentation Slide.	ALL	
12/12/22	ATC Meeting	Showed final presentation slide	Jawad, Liya, Laila	Suggested some modification
14/12/22	1.Jawad 2.Moazzul 3.Laila 4.Liya 5.Sijan	Modification in Presentation slide	Moazzul, Sijan	
19/12/22	1.Jawad 2.Moazzul 3.Laila 4.Liya 5.Sijan	Mock presentation	ALL	Suggested to add video
22/12/22	1.Jawad 2.Moazzul 3.Laila 4.Liya 5.Sijan	Final presentation	ALL	
23/12/22	Everyone	Final Report Preparing	ALL	

Table- Team Logbook EEE-400C

Table 23: Team logbook -400C

Date/Time/Place	Attendee	Summary of Meeting Minutes	Responsible	Comment by ATC
02/02/23	ATC Meeting	Discussed about the progress of hardware implementation	All	Approve of final components list
06/02/23- 12/02/23	All	Completing sensor synchronization	All	
16/02/23	ATC meeting	Showed progress and data findings	All	Suggested to show the data in one graph and to measure in
26/02/23		Taking preparation of progress presentation and making slides	All	
02/03/23	All	Progress Presentation		Receive feedback from other ATC panels.
15/03/23	1.Liya 2.Moazzul 3.Sijan	Work on the Feedback from Progress presentation	Liya, Moazzul, Sijan	
16/03/23	ATC meeting	Discussed about PCB design and final hardware design	All	Suggested to do PCB design and give ideas about final hardware design.
20/03/23	1.Jawad 2.Laila	Working on Design efficiency and synthesizing code and data calculation.	Jawad, Laila	

23/03/23	1.Liya 2.Moazzul 3.Sijan	Collected data and findings and working on the efficiency	Liya, Moazzul, Sijan	
29/03/23	All	Collected Data in different Weather Condition for different measurement	All	
09/04/23	All	Completed all the research and report Preparation	All	
13/04/23	ATC Meeting	Showed all data, graphs and designs	All	Suggested to set Timer on the display, give feedback on graphs and suggestion.
16/04/23	All	Poster making	All	
20/04/23	All	Mock Presentation On poster	All	Suggested some changes on Poster and feedback for presentation. Also, told the guideline about the project showcase.

Picture:

Legal Consent Form:

BRAC UNIVERSITY
Inspiring Excellence

Department of EEE
Spring 2023
EEE400C
BRAC University

Name	ID
Abdullah Al Jawad	21121038
MD. Moazzul Islam	19121020
Rajia Jannat Liya	18121038
Laila Khairun Nahar	19121025
S M Shahriar Kabir Sijan	19121052

ATC Panel- 05
Group- 07

Project Name: Design of Charge Controller for Solar PV Systems

This is to acknowledge that group- 07 from FYDP-C has taken permission to work in BRAC university rooftop under supervision.

Namul
20.03.23
Md. Nazrul Islam
Signature

Fig 24: “Legal Consent form” from Department

Flat Owner Consent Form:



Name	ID
Abdullah Al Jawad	21121038
MD. Moazzul Islam	19121020
Rajia Jannat Liya	18121038
Laila Khairun Nahar	19121025
S M Shahriar Kabir Sijan	19121052

ATC Panel- 05
Group- 07

Project Name: Design of Charge Controller for Solar PV Systems

This is to acknowledge that group- 07 from FYDP-C has taken permission to work in your premises to collect Data.

MD. Babul Hossain
Signature (Flat Owner)

Fig 25: Flat Owner Consent Form

Related code/theory

```
#include <TimerOne.h>
```

```
#include <LiquidCrystal_I2C.h>
```

```
#define LOAD_VOLT 10.0
```

```
#define FLOAT_CHA 12.0
```

```
#define FULL_CHA 13.0
```

```
#define CHA_RECON 10.0
```

```
#define AVG_NUM 10
```

```
#define solAmps_SCALE 0.026393581
```

```
#define solVolts_SCALE 0.017922580
```

```
#define batVolts_SCALE 0.015256257
```

```
#define LED_RED A1
```

```
#define LED_YELLOW A0
```

```
#define LED_GREEN 13
```

```
#define LOAD_PIN 12
```

```
#define PWM_PIN 6
```

```
#define ONE_SECOND 50000
```

```
byte battery_icons[6][8] = {
```

```
  { 0b01110, 0b11011, 0b10001, 0b10001, 0b10001, 0b10001, 0b10001, 0b11111 },
```

```
  { 0b01110, 0b11011, 0b10001, 0b10001, 0b10001, 0b10001, 0b11111, 0b11111 },
```

```
  { 0b01110, 0b11011, 0b10001, 0b10001, 0b10001, 0b11111, 0b11111, 0b11111 },
```

```
  { 0b01110, 0b11011, 0b10001, 0b11111, 0b11111, 0b11111, 0b11111, 0b11111 },
```

```

    { 0b01110, 0b11011, 0b11111, 0b11111, 0b11111, 0b11111, 0b11111, 0b11111 },
    { 0b01110, 0b11111, 0b11111, 0b11111, 0b11111, 0b11111, 0b11111, 0b11111 }
};

#define SOLAR_ICON 6

byte solar_icon[8] = { 0b11111, 0b10101, 0b11111, 0b10101, 0b11111, 0b10101, 0b11111, 0b00000
};

#define PWM_ICON 7

byte PWM icon[8] = { 0b11101, 0b10101, 0b10101, 0b10101, 0b10101, 0b10101, 0b10101,
0b10111 };

enum chargerMode { off,
    on,
    bulk,
    bat_float } chargerState;

float solVolts, solAmps, batVolts, solWatts;

int pwmVal = 0;

unsigned int seconds = 0;

unsigned int prev_seconds = 0;

unsigned int interrupt_counter = 0;

bool loadStatus = false;

bool fullyCharged = false;

// UPDATE

int bulkmm = 0, bulkss = 0;

int floatmm = 0, floatss = 0;

LiquidCrystal_I2C lcd(0x27, 20, 4);

```

```

void setup() {
  Serial.begin(115200);
  lcd.init();
  lcd.backlight();
  for (int batchar = 0; batchar < 6; ++batchar) {
    lcd.createChar(batchar, battery_icons[batchar]);
  }
  lcd.createChar(PWM_ICON, PWM_icon);
  lcd.createChar(SOLAR_ICON, solar_icon);

  pinMode(LED_RED, OUTPUT);
  pinMode(LED_GREEN, OUTPUT);
  pinMode(LED_YELLOW, OUTPUT);
  pinMode(LOAD_PIN, OUTPUT);
  pinMode(PWM_PIN, OUTPUT);
  digitalWrite(LOAD_PIN, HIGH);
  digitalWrite(PWM_PIN, LOW);

  Timer1.initialize(20); // us, 50KHz
  Timer1.pwm(PWM_PIN, 0);
  Timer1.attachInterrupt(callback);

  lcd.setCursor(0, 0);
  lcd.print("SOL");
  lcd.setCursor(4, 0);
  lcd.write(SOLAR_ICON);
  lcd.setCursor(8, 0);
  lcd.print("BAT");

```

```

}
void loop() {
  read_data();
  run_charger();
  load_control(batVolts > LOAD_VOLT);

  if (prev_seconds != seconds) {
    led_output();
    lcd_display();

    if (chargerState == bat float) {
      floatss++;
      if (floatss >= 60) {
        floatss = 0;
        floatmm++;
      }
    } else if (chargerState == bulk) {
      bulkss++;
      if (bulkss >= 60) {
        bulkss = 0;
        bulkmm++;
      }
    } else {
      bulkss = 0;
      bulkmm = 0;
      floatss = 0;
      floatmm = 0;
    }
  }
}

```

```

    prev_seconds = seconds;
}
}

void callback() {
    if (interrupt_counter++ > ONE_SECOND) {
        interrupt_counter = 0;
        seconds++;
    }
}

int read_adc(int channel) {
    int i, temp, sum = 0;

    for (i = 0; i < AVG_NUM; i++) {
        temp = analogRead(channel);
        sum += temp;
        delayMicroseconds(50);
    }
    Serial.print(sum / AVG_NUM);
    Serial.print(" : ");
    return (sum / AVG_NUM);
}

void read_data(void) {
    solVolts = read_adc(A6) * solVolts_SCALE;
    solAmps = abs(read_adc(A3) * solAmps_SCALE - 13.51);
}

```

```

batVolts = read_adc(A2) * batVolts_SCALE;

Serial.println();

solWatts = solAmps * solVolts;

if (solAmps < 0) solAmps = 0;

if (solWatts < 0) solWatts = 0;

if (batVolts > 15.5) batVolts = 0;

else if (batVolts < 5.0) batVolts = 0;

}

void set_pwm_duty(void) {

  pwmVal = (FULL_CHA - batVolts) * 1000;

  Timer1.pwm(PWM_PIN, pwmVal);

  pwmVal = map(pwmVal, 1000, 0, 0, 100);

}

void run_charger(void) {

  if (solVolts > 10) {

    if (batVolts <= CHA_RECON && fullyCharged) fullyCharged = false;

    else if (batVolts >= FULL_CHA && !fullyCharged) {

      fullyCharged = true;

      chargerState = off;

      digitalWrite(PWM_PIN, LOW);

      pwmVal = 0;

    } else if (!fullyCharged) {

      chargerState = on;

      if (batVolts >= FLOAT_CHA) {

        set_pwm_duty();

      }

    }

  }

}

```



```

    chargerState = bat_float;
} else {
    pwmVal = 100;
    digitalWrite(PWM_PIN, HIGH);
    chargerState = bulk;
}
}
} else {
    chargerState = off;
    digitalWrite(PWM_PIN, LOW);
    pwmVal = 0;
}
}

void load_control(boolean new_status) {
    if (loadStatus != new_status) {
        loadStatus = new_status;
        digitalWrite(LOAD_PIN, !loadStatus);
    }
}

void light_led(char pin) {
    static char last_lit;
    if (last_lit == pin) return;
    if (last_lit != 0) digitalWrite(last_lit, LOW);
    digitalWrite(pin, HIGH);
    last_lit = pin;
}

```

```

void led_output(void) {
    static char last_lit;

    if (batVolts > 14.1) light_led(LED_YELLOW);
    else if (batVolts > 11.9) light_led(LED_GREEN);
    else light_led(LED_RED);
}

```

```

void lcd_display() {
    lcd.setCursor(0, 1);

    if (solVolts > 10) lcd.print("PV-In");
    else lcd.print("-----");

    lcd.setCursor(0, 2);

    lcd.print(solAmps);

    lcd.print("A");

    lcd.setCursor(0, 3);

    lcd.print(solWatts);

    lcd.print("W ");

    lcd.setCursor(8, 1);

    lcd.print(batVolts);

    lcd.setCursor(8, 2);

    if (chargerState == on) lcd.print("ON ");
    else if (chargerState == off) lcd.print("OFF ");
    else if (chargerState == bulk) lcd.print("BULK ");
}

```

```

else if (chargerState == bat_float) lcd.print("FLOAT");

int pct = 100.0 * (batVolts - 11.3) / (12.7 - 11.3);
if (pct < 0) pct = 0;
else if (pct > 100) pct = 100;

lcd.setCursor(12, 0);
lcd.write((pct * 5 / 100));

lcd.setCursor(8, 3);
pct = pct - (pct % 10);
lcd.print(pct);
lcd.print("% ");

lcd.setCursor(15, 0);
if (chargerState == off) lcd.print("OFF ");
else if (chargerState == bulk) lcd.print((String)bulkmm + ":" + bulkss + " ");
else if (chargerState == bat_float) lcd.print((String)floatmm + ":" + floatss + " ");

// lcd.setCursor(15, 0);
// lcd.print("PWM");
// lcd.setCursor(19, 0);
// lcd.write(PWM_ICON);
lcd.setCursor(15, 1);
lcd.print(" ");
lcd.setCursor(15, 1);
if (chargerState == off) lcd.print("OFF");
else {

```

```

    lcd.print(pwmVal);
    lcd.print("% ");
}
lcd.setCursor(15, 2);
lcd.print("LOAD");
lcd.setCursor(15, 3);
if (loadStatus) lcd.print("On ");
else lcd.print("Off ");
spinner();
}

```

```

String pad(int val) {
    if (val > 9) return (String)val;
    else (String) "0" + val;
}

```

```

void spinner(void) {
    static int cspinner;
    static char spinner_chars[] = { '*', '*', '*', '!', '! };
    cspinner++;
    lcd.print(spinner_chars[cspinner % sizeof(spinner_chars)]);
}

```