

Flood Monitoring And Warning System For Embankment Using IoT

By
Aparup Dutta
17321032
Sanchoy Roy
17321001
Hatif Asrar Ahmed
16121069

A thesis submitted to the Department of Electrical & Electronic Engineering in partial fulfillment of the requirements for the degree of Bachelor of Science in Electrical & Electronic Engineering

Electrical & Electronic Engineering
Brac University
December 2021

© 2021. BRAC UNIVERSITY
All rights reserved.

Declaration

It is hereby declared that

1. The thesis submitted is our own original work while completing degree at Brac University.
2. The thesis does not contain material previously published or written by a third party, except where this is appropriately cited through full and accurate referencing.
3. The thesis does not contain material which has been accepted, or submitted, for any other degree or diploma at a university or other institution.
4. We have acknowledged all main sources of help.

Student's Full Name & Signature:

Aparup Dutta

Sanchoy Roy

Aparup Dutta

17321032

Sanchoy Roy

17321001

Hatif Asrar Ahmed

Hatif Asrar Ahmed

16121069

Approval

The thesis/project titled “[Thesis/Project Title]” submitted by

1. Aparup Datta (17321032)
2. Sanchoy Roy (17321001)
3. Hatif Asrar Ahmed (16121069)

Of Summer, 2021 has been accepted as satisfactory in partial fulfillment of the requirement for the degree of B. Sc. in Electrical & Electronic Engineering on 15 December 2021.

Examining Committee:

Supervisor:
(Member)

Dr. Mohammed Belal Hossain Bhuian
Associate Professor, Department of EEE
Brac University

Program Coordinator:
(Member)

Dr. Abu S.M. Mohsin
Assistant Professor, Department of EEE
Brac University

Departmental Head:
(Chair)

Dr. Md. Mosaddequr Rahman
Professor & Chairperson, Department of EEE
Brac University

Abstract

In this advanced world of technology, Internet of Things (IoT) is an indispensable technology that can be used in various fields for solving real life problems. This study focuses one of the most important real-life issues for Bangladesh which is flood monitoring and warning system. In this work, a well-maintained embankment has been set up with different measuring devices to collect real data for flood monitoring. This system will incorporate the measurement of average rainfall, and humidity of air, water level of a specific river of a particular area of Bangladesh. A special indication through real data will act as a warning system so that damage can be reduced due to flooding. The system can be integrated with cloud server to monitor remotely. This systemized sensor data will eventually be delivered to the Water Board of that area and to people in the flood prone area with a critical condition warning alert via message/call in mobile phones. To design the system, a simulation has been performed to validate the design. After that a prototype of interfacing of the water level detection, soil moisture, humidity and temperature sensors including a microcontroller has been implemented to get the real data. This study will create impact on the safety of the local safe residents living nearby the flood-prone areas.

Keywords: IoT, Flood Monitoring, Warning System, Water level detection, Flood Management.

Acknowledgement

We thank Almighty Allah for giving us courage, patience, opportunity, determination and strength to continue our work in this COVID19 situation.

We would like to thank our supervisor, Dr. Mohammed Belal Hossain Bhuian, Associate Professor in the Department of Electrical and Electronic Engineering at BRAC University, for his encouragement and assistance throughout the project. Without your unwavering intellectual and spiritual support, this endeavor would be impossible.

We would like to thank a few people for their help, encouragement, motivation and inspiration in completing our thesis project.

We would like to express our appreciation to all colleagues and others who have supported us and helped us complete the project.

Table of Contents

Declaration.....	ii
Approval	iii
Abstract.....	iv
Acknowledgement	v
Table of Contents	vi
List of Tables	viii
List of Figures.....	ix
List of Acronyms	xi
Chapter 1 Introduction.....	1
1.1 Background	1
1.2 Literature Review.....	3
1.3 Motivation.....	6
1.4 Objective	6
1.5 Organization of the Thesis	7
Chapter 2 Theoretical Background.....	8
Chapter 3 System Design and Methodology.....	13
3.1 Requirement.....	13
3.2 Component and Specifications	13
3.3 System Block Diagram	20
3.4 System Algorithm and Flowchart	21

3.5 System Simulation & Setup	24
3.5.1 System Simulation	24
3.5.2 Interfacing Temperature Sensor.....	25
3.5.3 Interfacing Water Sensor	26
3.5.4 Interfacing Rain Sensor.....	27
3.5.5 Interfacing Soil Sensor.....	28
3.5.6 Centralized Circuit	28
3.6 Hardware Setup.....	30
3.7 Methodology	32
3.7.1 Case-1 (Normal Condition).....	32
3.7.2 Case-2 (Moderate Condition)	33
3.7.3 Case-3 (Critical Condition).....	33
Chapter 4 Results Analysis & Discussion	35
4.1 Observing the sensors data.....	35
4.2 Graphical Analysis of Sensor data in different condition	42
4.2.1 Sensor Reading for Normal Conditions:-	42
4.2.2 Sensor Reading for Moderate scenario	47
4.2.3 Sensor Reading for Critical Scenario.....	52
4.3 Simulation Result:-	58
Chapter 5 Conclusion and Future Work.....	59

References:.....60

List of Tables

Table 3.1: Specifications for Rain Sensor..... 14

Table 3.2: Specifications for Water Sensor 15

Table 3.3: Specifications for Temperature Sensor..... 16

Table 3.4: Specifications for Rain Sensor..... 17

Table 3.5: Different parameters for Case-132

Table 3.6: Different parameters for Case-233

Table 3.7: Different parameters for Case-333

List of Figures

Figure 1.1: A map showing Flood Affected Zones in Bangladesh.....	2
Figure 2.1: Visual representation of the System.....	9
Figure 2.2 : Diagram of the embankment.....	10
Figure 2.3:Visual representation of Warning System	12
Figure3.1:Rain sensor and the Arduino Connections diagram.....	14
Figure 3.2: Water level Sensor pin diagram	15
Figure 3.3: Diagram of a soil moisture sensor.....	16
Figure 3.4: Pin Configuration of Temperature Sensor.....	17
Figure 3.5: Pin Configuration of Esp32.....	18
Figure 3.6: Pin configuration of Arduino	19
Figure 3.7: Block Diagram of the System	20
Figure 3.8: Flowchart of the program for simulation	21
Figure 3.9: Circuit Diagram of a Temperature Sensor in Proteus.....	25
Figure 3.10: Circuit Diagram of a Water Sensor in Proteus.....	26
Figure 3.11: Circuit Diagram of Rain Sensor in Proteus.....	27
Figure 3.12: Circuit Diagram of Soil Sensor in Proteus.....	28
Figure 3.13: Diagram of the Centralized Circuit.....	29
Figure 3.14: Hardware Setup.....	31
Figure 3.15: Result after interfacing sensor.....	32

Figure 4.1: Graphical Representation of Temperature sensor from Thingspeak.....	34
Figure 4.2 : Graphical Representation of Rain and Water sensor from Thingspeak.....	36
Figure 4.3: Graphical Representation of Soil moisture sensor from Thingspeak.....	36
Figure 4.4 : Plot of Temperature Sensor;Data taken on 7 th -8 th December 2021.....	37
Figure 4.5: Plot of Humidity Sensor;Data taken on 7 th -8 th December 2021.....	38
Figure 4.6: Plot of Rain Sensor;Data taken on 7 th -8 th December 2021.	39
Figure 4.7 : Plot of Water level Sensor;Data taken on 7 th -8 th December 2021	40
Figure 4.8: Plot of Soil Moisture Sensor;Data taken on 7 th -8 th December 2021	41
Figure 4.9: Plot of Temperature Sensor;Data taken on Normal Condition	42
Figure 4.10 : Plot of Humidity Sensor;Data taken on Normal Condition	43
Figure 4.11: Plot of Rain Sensor;Data taken on Normal Condition	44
Figure 4.12: Plot of Water level Sensor;Data taken on Normal Condition	45
Figure 4.13 : Plot of Soil Moisture Sensor;Data taken on Normal Condition.....	46
Figure 4.14: Plot of Temperature Sensor;Data taken on Moderate Condition	47
Figure 4.15: Plot of Humidity Sensor;Data taken on Moderate Condition	48
Figure 4.16 : Plot of Rain Sensor;Data taken on Moderate Condition	49
Figure 4.17: Plot of Water Level Sensor;Data taken on Moderate Condition.....	50
Figure 4.18: Plot of Soil Moisture Sensor;Data taken on Moderate Condition.....	51
Figure 4.19: Plot of Temperature Sensor;Data taken on Critical Condition.....	52
Figure 4.20 : Plot of Humidity Sensor;Data taken on Critical Condition.....	53
Figure 4.21: Plot of Rain Sensor;Data taken on Critical Condition	54
Figure 4.22: Plot of Water level Sensor;Data taken on Critical Condition	55
Figure 4.23: Plot of Soil Moisture Sensor;Data taken on Critical Condition	56
Figure 4.24: Message From Warning System.....	57
Figure 4.25 :Simulation Result Of the System	58

List of Acronyms

IoT	Internet of Things
IFTTT	If This Than That
WSN	Wireless Sensor Network

Chapter 1

Introduction

1.1 Background

“Floods Are Acts Of God, But Flood Losses Are Largely Acts of Man”

— Gilbert White.

Bangladesh, is a country in South-Asian region, is one of the victims of climate change which causes cyclones, soil erosions and floods. Various research studies have been conducted, analyzing the impact of climate change on Bangladesh and precautions for climate change [1].

Bangladesh is a country almost entirely situated on flat low land that is barely above sea level. almost 80% of the country is situated on a delta plate (with rivers and river banks). The climate of Bangladesh is infected by many monsoons. So, Bangladesh experiences both high and low amount of rain. Bangladesh residing near the equator has very hot and humid weather. Because of cyclones Bangladesh is in flood-prone region. As most of the region of Bangladesh is less than sea level, flood in Bangladesh occurs every year and has a negative impact in the economy of Bangladesh.

Considering the threats that flooding causes in our coastal communities, we are proposing a scientific and modern method that will help the residents and local authorities in predicting upcoming floods by recording the water levels of a specific area, along with several other sensors, to warn its residents, so that they can take proper precautions and shelter. It will eventually add immense benefits to the overall safety of the human lives and livestock, as well as adding economic benefits.

The features being studied are the location of flood-risk regions and the locations of water level increases. This is a Natural—Natural relationship because both locations of flood-risk regions

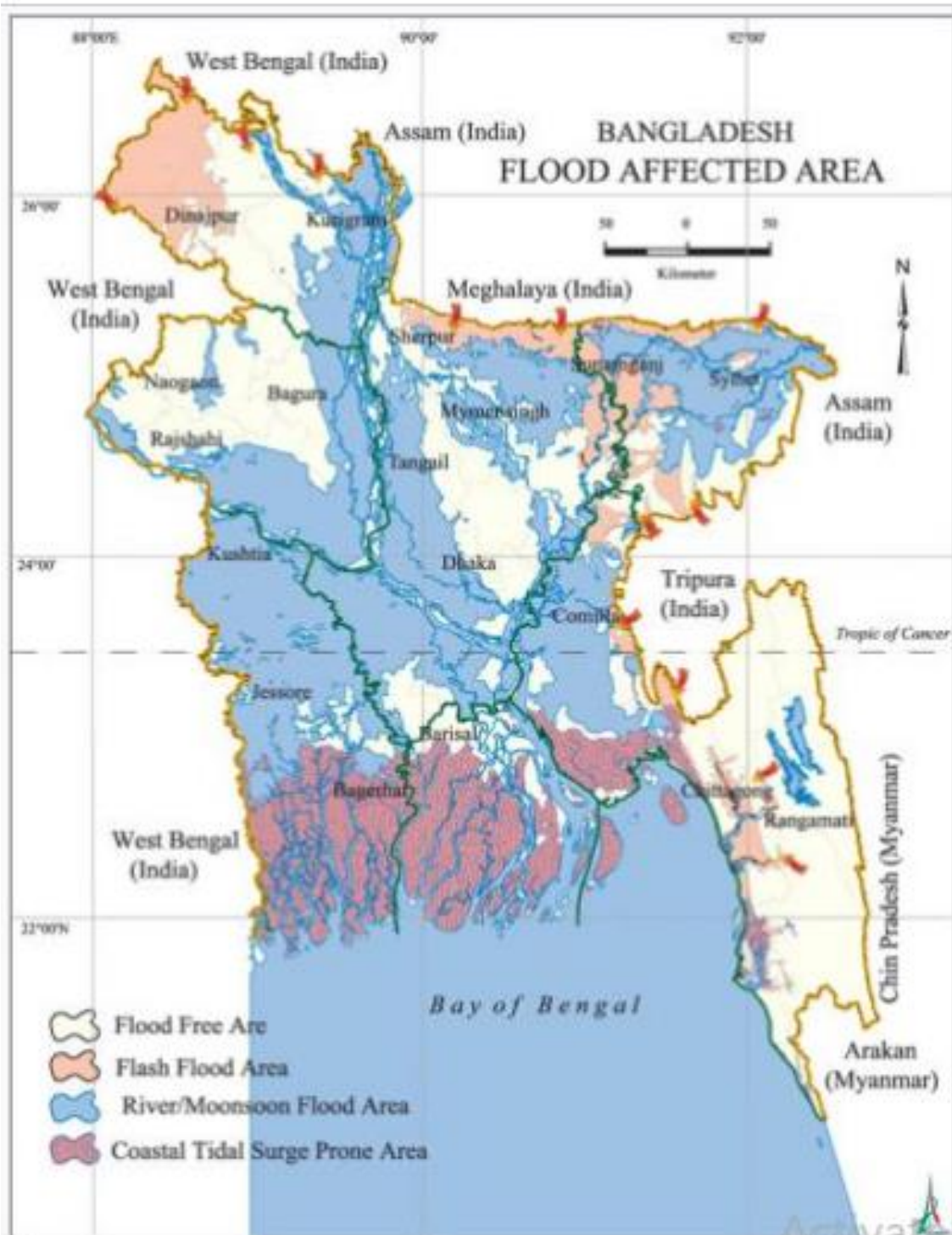

Figure 1.1: A map showing Flood Affected Zones in Bangladesh [2].

and water level increases are naturally occurring processes that are not created (but can be controlled) by humans [3].

Both locations of flood-risk regions and locations of water level increases demonstrate linearly concentrated patterns along the edges of major rivers and along the coastline. Regions at flood risk appear to overlap or be in extremely close proximity to regions of water level increases, demonstrating a strong positive relationship with occasional outliers (e.g. from cyclones). Since flood-risk regions are determined by the presence of water level increases, the relationship between the two features is correlational and causal (with the cause being locations of water level increases) [4].

1.2 Literature Review

As we went through a few papers and we found some work done on this venture. In spite of the fact that the work may differ but a great sum of data has been accumulated for the papers.

Khalaf et al. (2020), entails a different approach for the prediction of water level in their paper. Their approach emphasizes on the latest improvements on Internet of Things (IoT) and using a machine learning model for automated analysis of flood in order to prevent natural disasters [5]. Their research outcomes indicate that ensemble learning provides a more reliable tool to predict flood severity levels. However, their study is only limited to accumulating analytical data for improving preventive and control measures for river floods. Whereas, our paper mainly focuses on developing an alarming and warning system collaborating IoT and NodeMCU by constructing and managing embankments which can be integrated through a user interface system. Our system gather real life data and based on the reading sends out texts and emails to the threatened residents of the flood prone areas.

Anbarasan et al. (2019), proposes the ideas and methods for the detection of flood disaster based on IoT, Big Data (BD), and convolutional deep neural network (CDNN). In their paper, the input data is taken from the flood BD. Hadoop Distributed File System (HDFS) map-reduce minimizes the repeated data [6]. Repeated data are removed before pre-processing using

missing value imputation and normalization. The rule is then generated based on the pre-processed data and a set of properties. Lastly, the created rules are fed into the CDNN classifier, which categorizes them as a) having a possibility of flooding and b) having no chance of flooding. However, these data and study does not account for the embankment model and instant transmission of alert messages to the residents. That is where our study fills up the gap by managing embankments and alarming residents of the evident floods.

Sunkpho and Ootamakorn (2010) published his study on real-time monitoring of water conditions keeping in mind two main objectives: 1) as a communication channel for flooding between the concerned authorities and experts in order to improve their responsibilities and collaboration, and 2) as a web-based information source for the general people, responding to their need for information on water conditions and flooding [7]. The system is composed of three major components: sensor network, processing/transmission unit, and database/application server. Real-time data of water condition can be monitored remotely by utilizing wireless sensors. Users can view real-time water condition as well as the forecasting of the water condition directly from the web. Here, we see that Sunkpho and Ootamakorn tried to create a bridge between experts and authorities also keeping in my about the general public while developing the system [7]. But they have not focused on the imminent threat that floods pose in coastal or riverine communities. We aim to address that problem by building embankment and creating the alert system that could save the lives of millions.

Nandhini et al. (2021) published a similar paper which deals with the strategies of flood alerting system with help of Internet of Things (IoT) and mathematical modeling [8]. An embedded system would give the real time calculation along with Wireless Sensor Network (WSN) for computational processing, prediction and analysis that would help to send an alert message to the nearby surrounding. While Nandhini et al. worked on WSN, we focus more on send the message using NodeMCU.

The paper by Singh et al. (2020) represents the development of an IoT based flood monitoring and alerting system with weather forecasting through open weather API [9]. This project is based on Arduino which is set up with multiple different sensors. These values received from various sensors are sent to Android applications developed using technologies such as Java, XML, and Android Studio. This system will be used for early detection and prevention of floods in flood-prone areas. Weather forecasting system is not a particularly efficient way to predict floods. Collecting raw data from custom embankment makes the prediction and alarming system way more efficient.

Srinivas et al. (2020), in their paper, developed a system which relies on two NodeMCU boards in which one acts as transmitter and another as receiver while the ThingSpeak application acts as server [10]. The web server stores all the data in a private channel by default, but there is an option to share data to the general public by using the public channel. Results obtained show that the system can be used in flood prone areas. We have taken this thought one step further through the implementation of embankments in the flood prone areas and keeping the residents updated through texts in case of emergencies.

An IoT based flood monitoring and artificial neural network (ANN) based flood prediction is designed by Bande et al. (2017) whose major goal of is to keep track of humidity, temperature, pressure, rainfall, river water levels, and other data in order to provide flood predictions [11]. The AI method is used to collect data from sensors and communicate over Wi-Fi. While this system is mainly based on AI, integrating this system with an embankment management is not sustainable enough. That's why, we took a conventional approach by using Arduino and user interface systems to gather data and spread caution.

“Key issues on seepage analysis in mountain river embankment” by Wenjia Tang, Jiamin Hong, Xinzhou Huang and Jian Huang et al. (2018) suggested the workable embankment system

of the seepage for the mountain river to protect from flood flow. Depending on the mathematical and analytical analysis for the measurement of the sustainable and workable embankment they have constructed their system [12]. Meanwhile, Their system is workable only for mountain river and seepage. This is their limitation and again their system is only embankment based which ultimately don't cover different other aspects for flood monitoring and protection. On the other hand, our system successfully works for the flood monitoring and warning with embankment which covers the bigger aspect of flood. Furthermore, we have proposed the IOT based technological system which is the most modern, advanced and accurate solution for the flood problem.

1.3 Motivation

In an average year, in Bangladesh about 26,000 square kilometers (around 18% of the country) is flooded, killing over 5,000 people and destroying more than seven million homes. Many of the residents of these areas are not aware of the incoming floods beforehand and thus fall victim to terrible losses. Hence our goal was to spread this awareness amongst the local riverine residents so that they could be benefited during the extreme catastrophes. By giving warnings and reports of the water level of the river, they could then prepare for the flood, which would save lives and minimize the financial losses.

1.4 Objective

The main objective of this paper is to develop a flood monitoring and a warning system that ensures the safety of the locals. The data collected from the system will be analyzed further to improve the standard and safety of living in the flood prone areas which in turn would improve the quality of living and growth of Bangladesh. The system will be a smart IoT based system which makes it easier to carry and process information.

1.5 Organization of the Thesis

The book is organized is as follows:

In chapter 1, we have discussed the background and a general overview of our project. It provides details about the flood problems of Bangladesh and motivates us to develop a way to fight it. Also, a detailed literature review of the project has been done here.

In chapter 2, the theoretical background of our project. The ideas and science behind the whole plan. It discusses the alarming or warning system and the management system that is conducted in our project.

Chapter 3 provides the overall simulation of the software part and the sensors we have used in our project. Additionally, the overall construction process and detailed overview of the embankment is also stated.

Chapter 4 depicts the overall results and data obtained throughout our study. It shows the graphs and analysis of our data and also dives into further discussions and comparisons.

Lastly, chapter 5 comprises the overall constraints faced and the future aspirations of our project. It also concludes our perspectives and learnings of the thesis project.

Chapter 2

Theoretical Background

During the rainy season the rivers of Bangladesh are full to the brim. When it rains cats and dogs and water flows above the danger level .It causes floods in flood prone areas of our country. Due to excessive rainfall the rivers and canals overflow their banks and makes a huge loss to the crop and property of people. To minimize the loss of people's crop, property and life we have proposed a system which is flood warning and monitoring with embankment using IOT technology.

All the sensors namely temperature sensor, water sensor, soil moisture sensor, rain sensor will give their respective data. Those data will be sent to the ESP32 (a microcontroller with integrated Wi-Fi and dual-mode Bluetooth).The ESP32 then with a user interface system will send the messages to the people of the risk prone area to warn them about the upcoming flood. For the monitoring system, all the sensors that have been positioned on the embankment will give their respective data .Those sensor data will be uploaded in the ThingSpeak IO cloud server. After taking all the data it will calculate and will generate the graphical representation. From the graphical representation statistical analysis will take place.

Warning Procedure:

A warning system consists of a number of key steps: monitoring rainfall and river flow rate; making forecasts about river water levels; monitoring soil moisture level of the embankment and flood extent. Interpreting forecasts for their meaning in terms of impact on those at risk, composing and disseminating warning messages; response by those at risk and emergency.

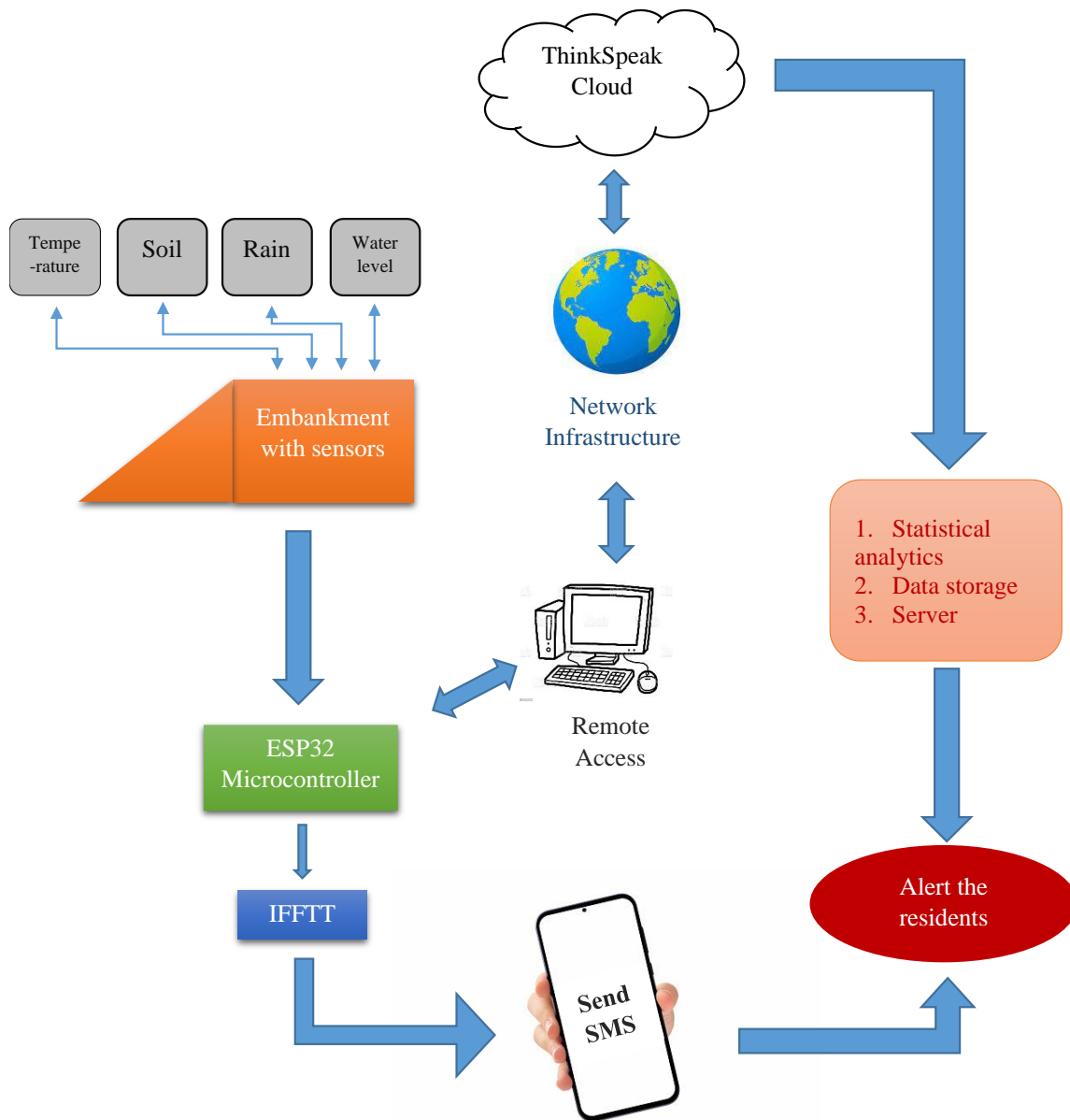

Figure 2.1: Visual representation of the System.

Water level detection: -

The water level sensor detects the water level with the increase of water. It can then feed that information into other devices that control what happens to the water after that. to sense the water level in river beds and check if they are in normal condition. If the water level increases more than the threshold value then the warning system is activated.

Temperature and Humidity of Air Sensing: -

Humidity measures the water vapor present in the atmosphere. Humidity measurement determines the amount of moisture present in the gas that can be a mixture of water vapor, nitrogen, argon or pure gas etc... Humidity sensors are of two types based on their measurement units. DHT11 is a digital temperature and humidity sensor.

Embankment Monitoring: -

An embankment that is built in order to prevent a river from over flowing. If well-constructed, riverside embankments can be relatively effective in stopping water spilling over onto adjacent land. This system consist of embankment prototype which is made of soil. So, the measurement of the embankment is following, the edge of the embankment is considered as 20 meter, From the top corner of the edge it has been extended up to 20 meter for the upper side of the Embankment body. From the starting part of the edge it has been extended up to 60 m. the height of the embankment is taken as 5 meter[8]. In order to, avoid complexity a scaling has been done as taking ratios to count a small measurement for the proto type. The ratios are

∴The edge of the embankment= $(20/300) = 0.06 \text{ m} = 6\text{cm}$.

∴From the top corner of the edge to the end of the Embankment body = $20/300 = 0.06\text{m} = 6 \text{ cm}$.

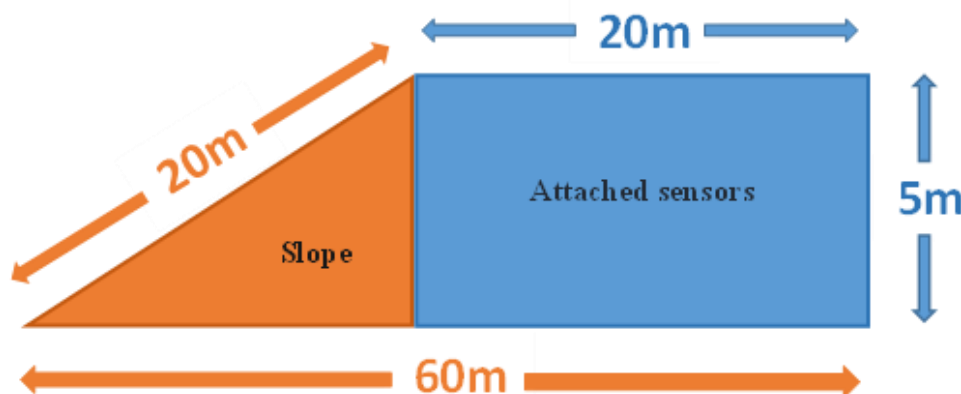

Figure 2.2: Diagram of the embankment.

∴ From the lower corner of the edge to the end of the Embankment body = $60/300=0.2\text{m}=20$ cm.

∴ The height of the embankment = $5/100=0.05$ m. = 5cm.

These parameters are centimeters used to build up the proto type embankment for our project. We have counted these ratios for the measurement.

The water level will be low, soil moisture will be dry and there will be no rain. In this case the river flow will be normal then the water level will be low and the embankment will be in good condition. When the water level will be medium, soil moisture will be soggy and it will rain. In this case the river flow will increase then the water level will be medium and the embankment will act as a support against the high river flow. The water level will be high, soil moisture will be extremely soggy and it will rain heavily. In this case the river flow will increase extremely then the water level will be extremely high and the embankment will be in critical condition against the high river flow .In this case the embankment may collapse anytime so the inhabitants will be notified with a message alert.

ThingspeakIO:-

ThingSpeak is an IoT based platform service that aggregate, visualize and analyze real-life data in a graphical representation. ThingSpeak provides instant visualizations of data posted by your devices to ThingSpeak. ThingSpeak can perform online analysis and processing of the data as it comes in. It is also used for the graphical representation of the sensor's data [19].

Message System:-

Esp32 is a microcontroller used as a Wi-Fi module through which data can be uploaded in cloud server . From the sensors the data has been collected. This data will be restored in the ESP32 cloud which can be said as IFTTT. Afterwards it will send the messages to the mobile

phone. This system consists of two digital devices (cell phones), one is the sender and other acts as receiver [17].

IFTTT is shorthand for If This Then That; it's an automation tool for connecting apps. By using this application, we can send messages to the phone. In this case, the sensors are connected with Esp32 by using the webhooks application of IFTTT.

(Sensor data) → (Esp32) → (IFTTT) → (Phone Message System)

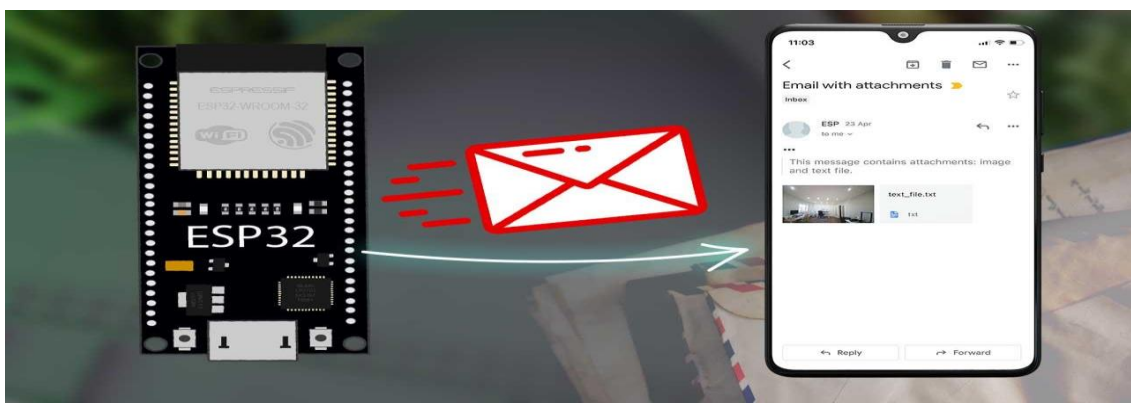

Figure 2.3:- Visual representation of Warning System

Chapter 3

System Design and Methodology

3.1 Requirement

Our whole system is based on developing a monitoring and warning system for embankments. In our project, we have built a prototype embankment for gathering real life data of temperature, soil moisture, humidity and rain. We have considered 3 conditions which gives us an overall overview and working procedure of the system. In our first condition, when there is no rain, the embankment remains dry and intact. The water level of the embankment remains optimum and there is no threat to the residents. In the second condition, we record the measurements given out by the sensors when slight rain occurs and immediately after the raining stops. As per the data gathered, we see that, in this case, the water level slightly increases and the soil moisture gets a bit soggy. For our third and final condition, we collect the data during relentless rain and find that, the water level in this case rises by a drastic level and the soil becomes very wet. This causes a risk to the embankment and it immediately triggers a warning text to the residents of that area to take shelter. This monitoring of the embankment and sending out warning texts is the main requirement of our project.

3.2 Component and Specifications

Rain Sensor

A rain sensor is made up of a rain detecting plate and an intelligence comparator. Water short circuits the tape of the printed circuits that is detected by the rain sensor. The sensor functions as a variable resistance that changes state: when the sensor is wet, the resistance increases, and when the sensor is dry, the resistance decreases [13].

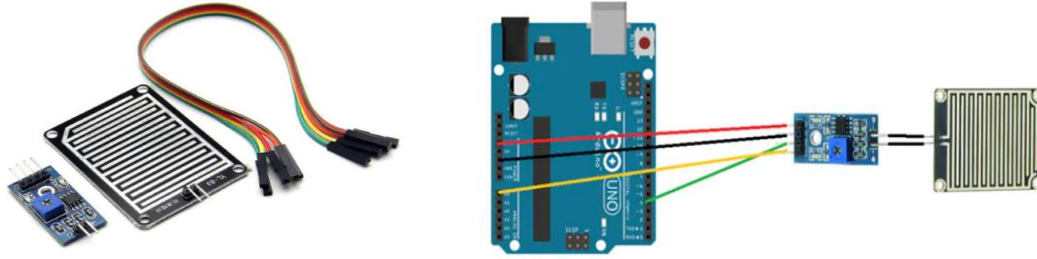

Figure3.1: Rain sensor and the Arduino Connections diagram.

Table3.1: - Specifications for Rain Sensor[18].

Sensor name	Parameter	Operating Current	Comparator chip	Sensitivity	Output type	LED lights indicators
Rain	value	15 mA	Lm393	Adjustable via Trimpot	Analog output voltage (AO) and Digital switching voltage (DO)	Power (red/green) and Output (red/green)

Water level Sensor:

Water level sensors can be used to measure the water level, monitor a sump pit, detect rainfall or detect leakage. Level measurements can be done inside containers or it can be the level of a river or lake. These measurements may be used to figure out how much stuff is in a closed container or how much water is flowing in open channels [14].

There are ten exposed copper traces on the sensor, five of which are power traces and five of which are sensing traces. These traces are interwoven so that per two power traces there is one sensory trace. When submerged, these traces are usually not linked but are bridged by water.

Table 3.2: - Specifications for Water Sensor [18].

Sensor name	Operating Voltage	Operating current	Sensor type	Detection type	Operating temperature	Humidity
Water	DC 3-5 V	less than 20mA	Analog	40mm x 60mm	10 degree Celsius to 30 degree Celsius	10%--40% non-condensing

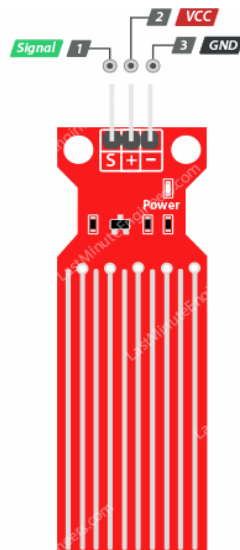

Figure3.2: Water level Sensor pin diagram

Soil Sensor:

Soil moisture sensors measure the volumetric water content in soil. Since the direct gravimetric measurement of free-soil moisture requires removing, drying, and weighing of a sample, soil moisture sensors measure the volumetric water content indirectly by using some other property of the soil, such as electrical resistance, dielectric constant, or interaction with neutrons, as a proxy for the moisture content [15].

Table3.3: - Specifications for Soil moisture Sensor [18].

Sensor name	Measuring range	Size	Sensor type	Power supply	Operating range	Current
soil	Moisture 0-99.9% temperature 0-60 degree Celsius	probe length 12cm to 38mm	FDR (frequency domain reflectometry)	DC 9-15 VOLT	0-60 DEGREE CELSIUS	25 mA

The fork-shaped probe, which has two exposed conductors, functions as a variable resistor (similar to a potentiometer) whose resistance changes with the amount of water in the soil.

The sensor contains a fork-shaped probe with two exposed conductors that penetrate the soil or some other point where the water content is to be measured. It acts as a variable resistance, whose resistance changes according to the humidity of the soil [15].



Figure3.3: - Diagram of a soil moisture sensor.

The sensor also contains an electronic module that connects the probe to the Arduino. The module generates an output voltage according to the resistance of the probe and is available on an analog output (AO) pin. The same signal is sent to a high precision LM393 comparator for digitization and is provided on a digital output (DO) pin. The module has a built-in potentiometer to set the sensitivity of the digital output (DO). A threshold value can be set with a potentiometer; If the moisture content exceeds the threshold value, the module outputs LOW, otherwise HIGH [15].

Temperature Sensor:

A temperature sensor is a device used to measure temperature. This can be air temperature, liquid temperature or the temperature of solid matter. Temperature sensors are used to measure temperature in many different applications and industries. They are all around us; present in both everyday life and more industrial settings. The sensor can operate with a 4 V to 30 V power supply and draws less than 60 μA during active temperature conversions, offering very little self-heating (below 0.08°C in still air) [16].

Table3.4: - Specifications for Temperature Sensor [18].

Sensor name	Item	Measurement Range	Humidity Accuracy	Temperature accuracy	Resolution	Package
Temperature	DHT11	20-90%RH, 0-50 $^\circ\text{C}$	$\pm 5\%RH$	$\pm 2^\circ\text{C}$	1	4 Pin Single, Row

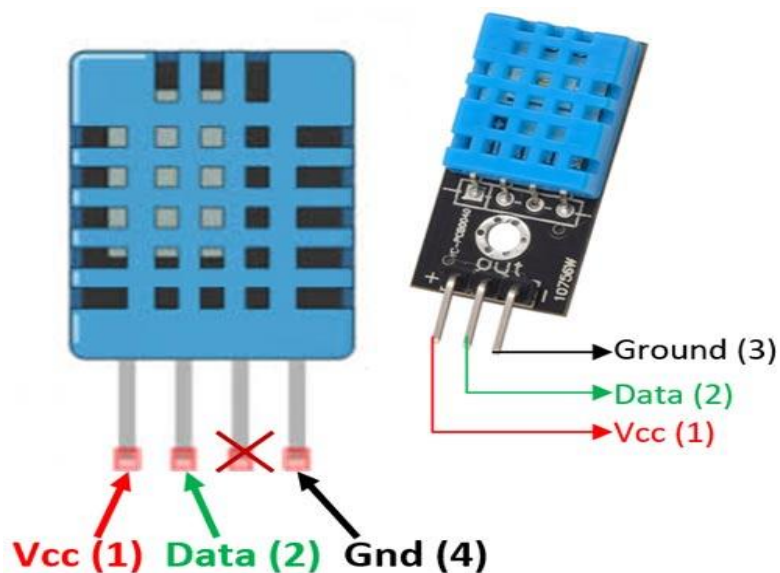

Figure3.4: - Pin Configuration of Temperature Sensor.

ESP32:

ESP32 is actually a low-cost, low-power Microcontroller with integrated Wi-Fi and Bluetooth. Basically, it is the successor to the ESP8266 which is also a low-cost Wi-Fi microchip albeit with vastly limited functionality [22].

It is an integrated antenna and RF balun, power amplifier, low-noise amplifiers, filters, and power management module. The entire solution takes up the least amount of printed circuit board area. This board is used with 2.4 GHz dual-mode Wi-Fi and Bluetooth chips by TSMC 40nm low power technology, power and RF properties best, which is safe, reliable, and scale-able to a variety of applications [23].

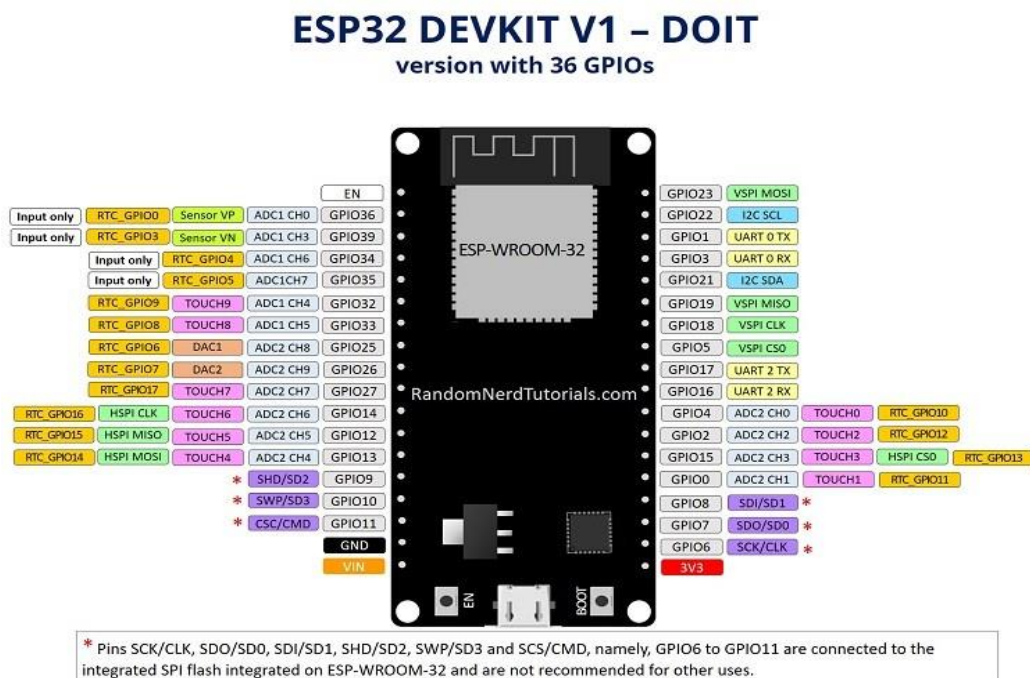

Figure3.5: - Pin Configuration of Esp32 [24].

ARDUINO:

Vin is the input voltage pin of the Arduino board used to provide input supply from an external power source. 5V pin is used as a regulated power supply voltage and it is used to give supply

to the board as well as onboard components. 3.3V pin of the board is used to provide a supply of 3.3V which is generated from a voltage regulator on the board. GND pin of the board is used to ground the Arduino board. Reset pin is used to reset the microcontroller. It is used to Resets the microcontroller. Analog Pins A0 to A5 are used as an analog input and it is in the range of 0-5V. Digital Pins 0 to 13 are used as a digital input or output for the Arduino board. Serial pins are also known as a UART pin. It is used for communication between the Arduino board and a computer or other devices. The transmitter pin number 1 and receiver pin number 0 is used to transmit and receive the data resp. External Interrupt Pins are used to produce the External interrupt and it is done by pin numbers 2 and 3. PWM Pins are used to convert the digital signal into an analog by varying the width of the Pulse. The pin numbers 3, 5, 6, 9, 10 and 11 are used as a PWM pin. SPI Pins are the Serial Peripheral Interface pin, which is used to maintain SPI communication with the help of the SPI library [21].

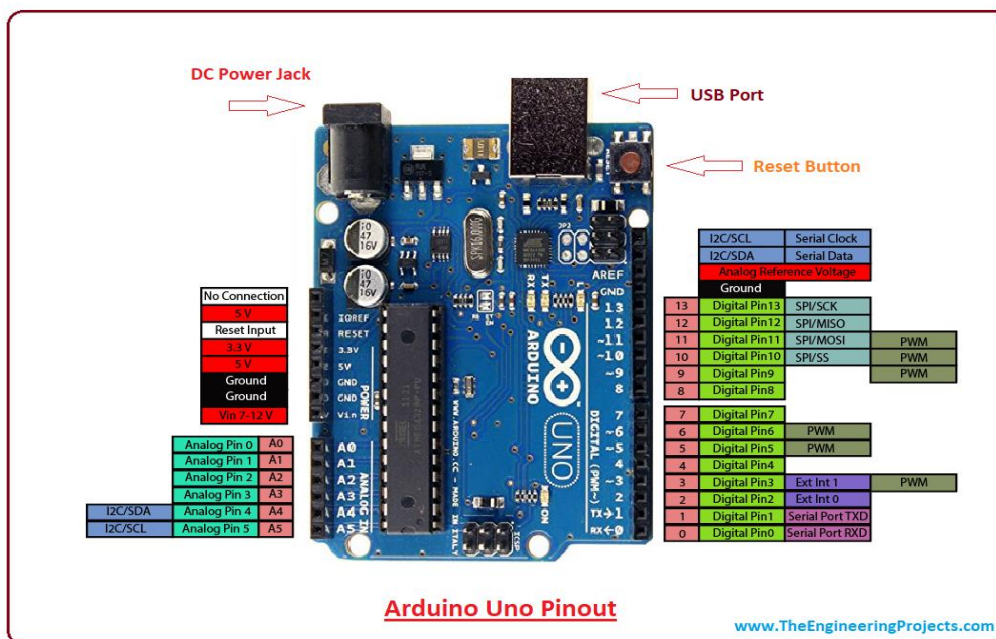

Figure3.6: - Pin configuration of Arduino [18]

3.3 System Block Diagram

Our whole system can be divided into two distinct divisions: The monitoring system & the warning system. All our sensors (temperature, soil, rain, moisture and water level) are connected to the embankment from where we will gather all the data. The data is then processed by ESP32 which triggers an email and SMS to the residents of the risk prone areas. Furthermore, the gathered data is uploaded to the cloud server ThinkSpeak to generate graphical representation. This graphical analysis of the data is used for the statistical analysis of our data and results.

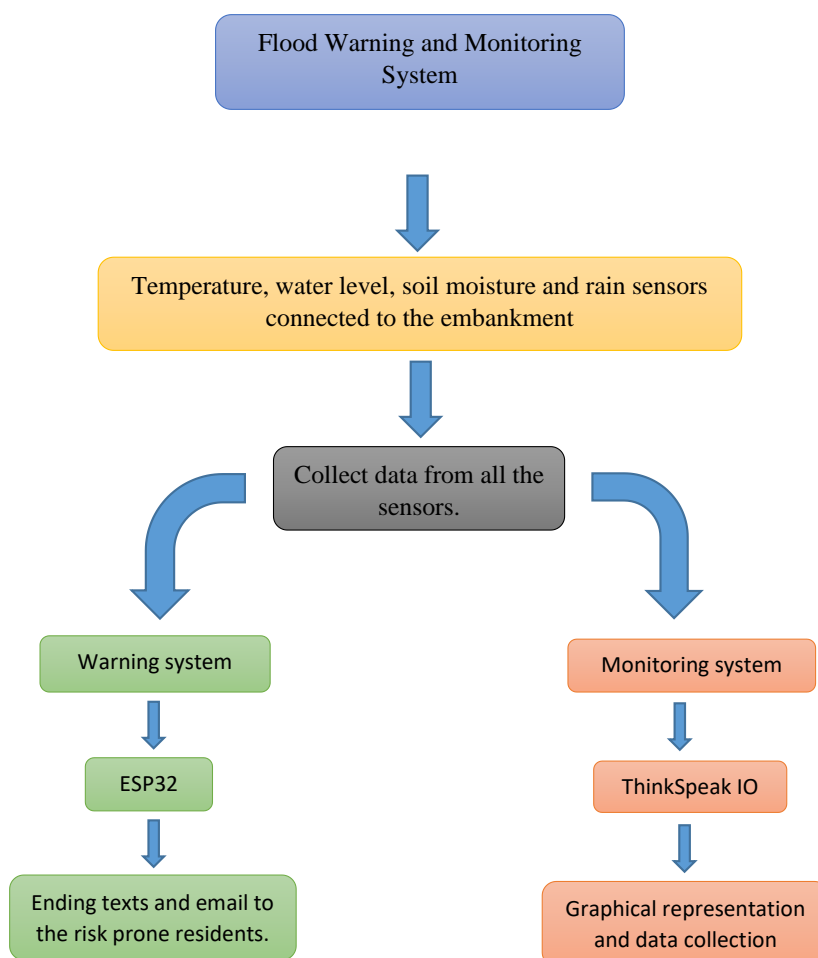
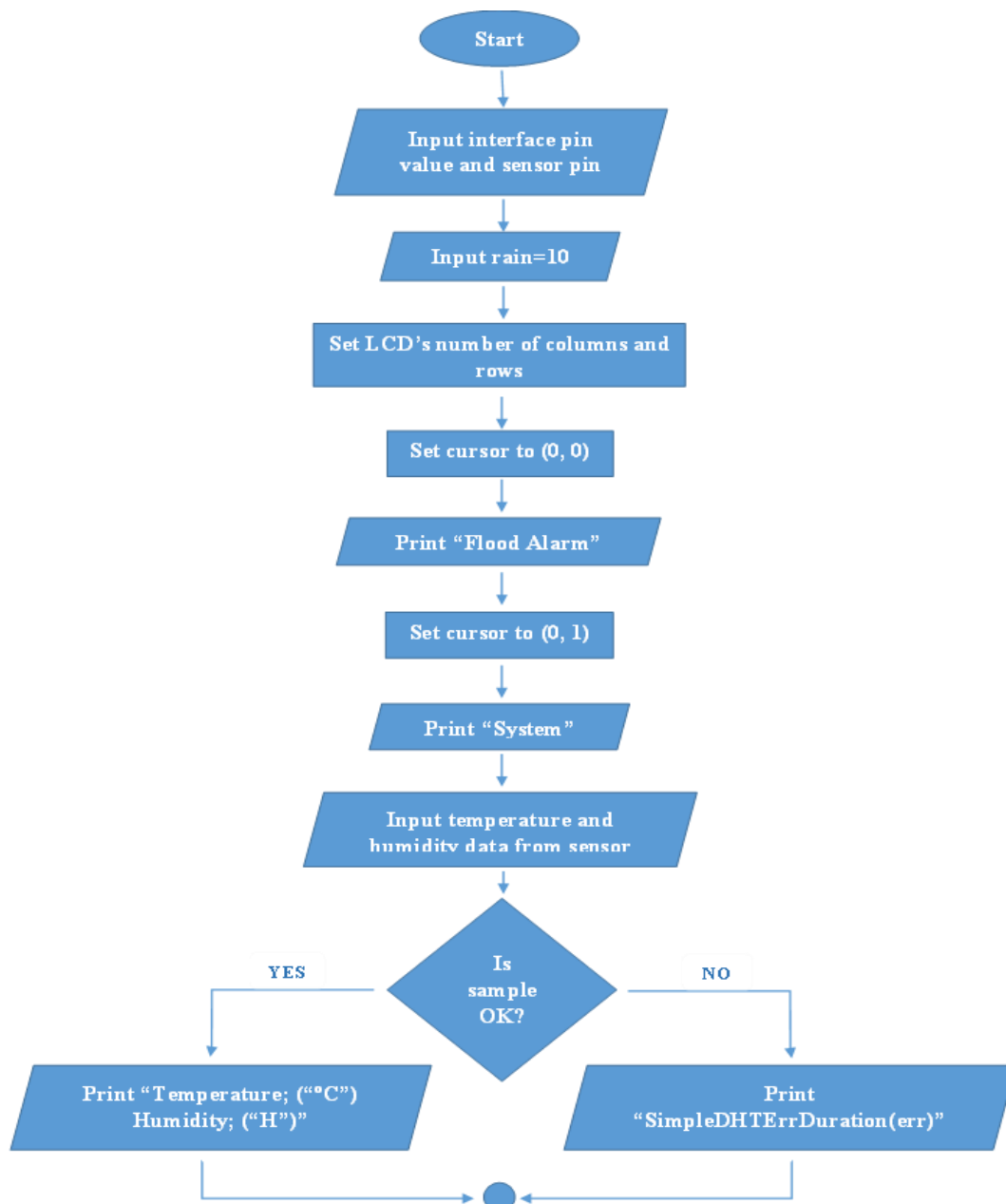

Figure3.7:- Block Diagram of the System .

3.4 System Algorithm and Flowchart

The system has been simulated on the basis of an algorithm developed in order to get sensor data from each sensor individually. The flowchart of the code is given below: -



To be continued

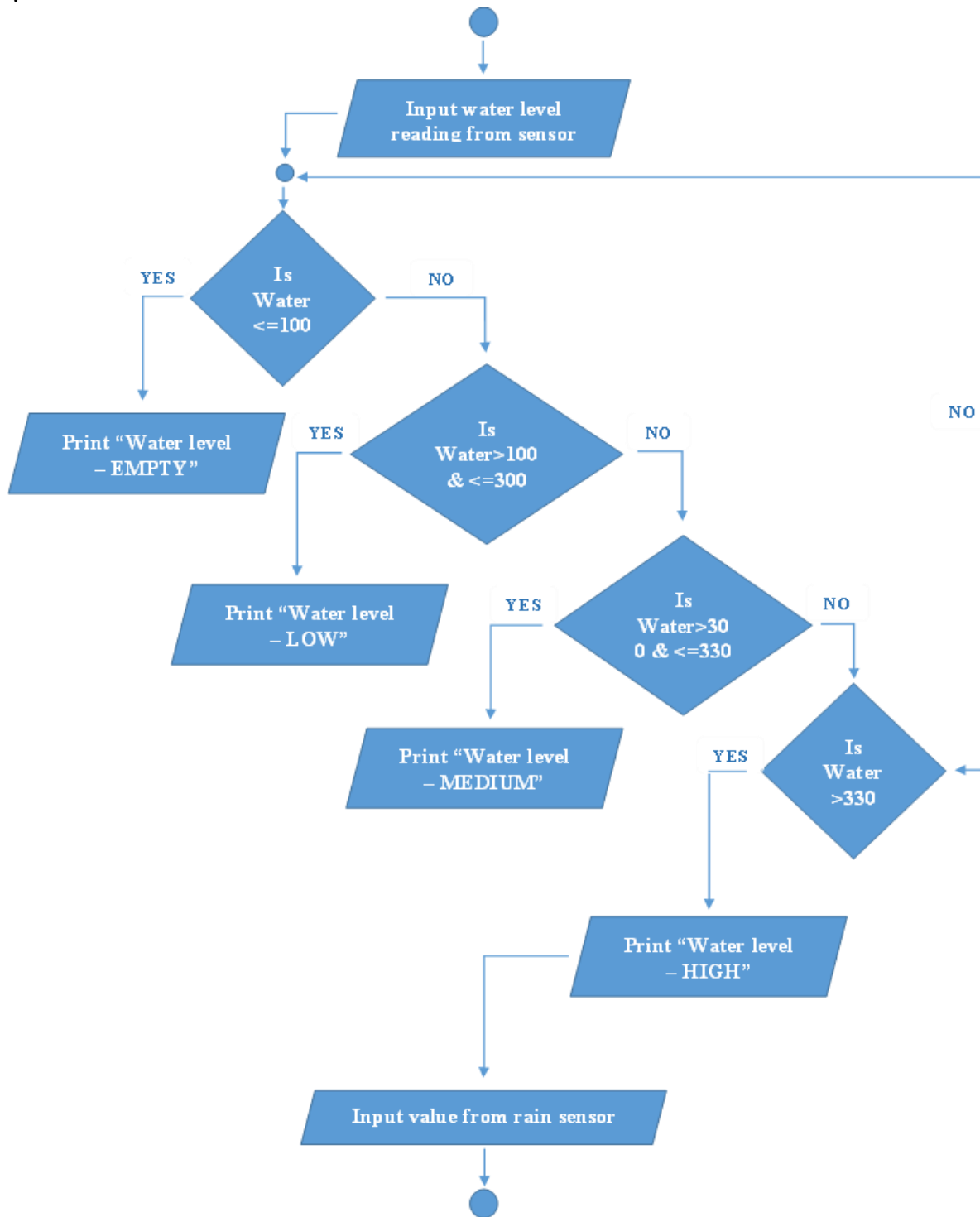

To be continued.

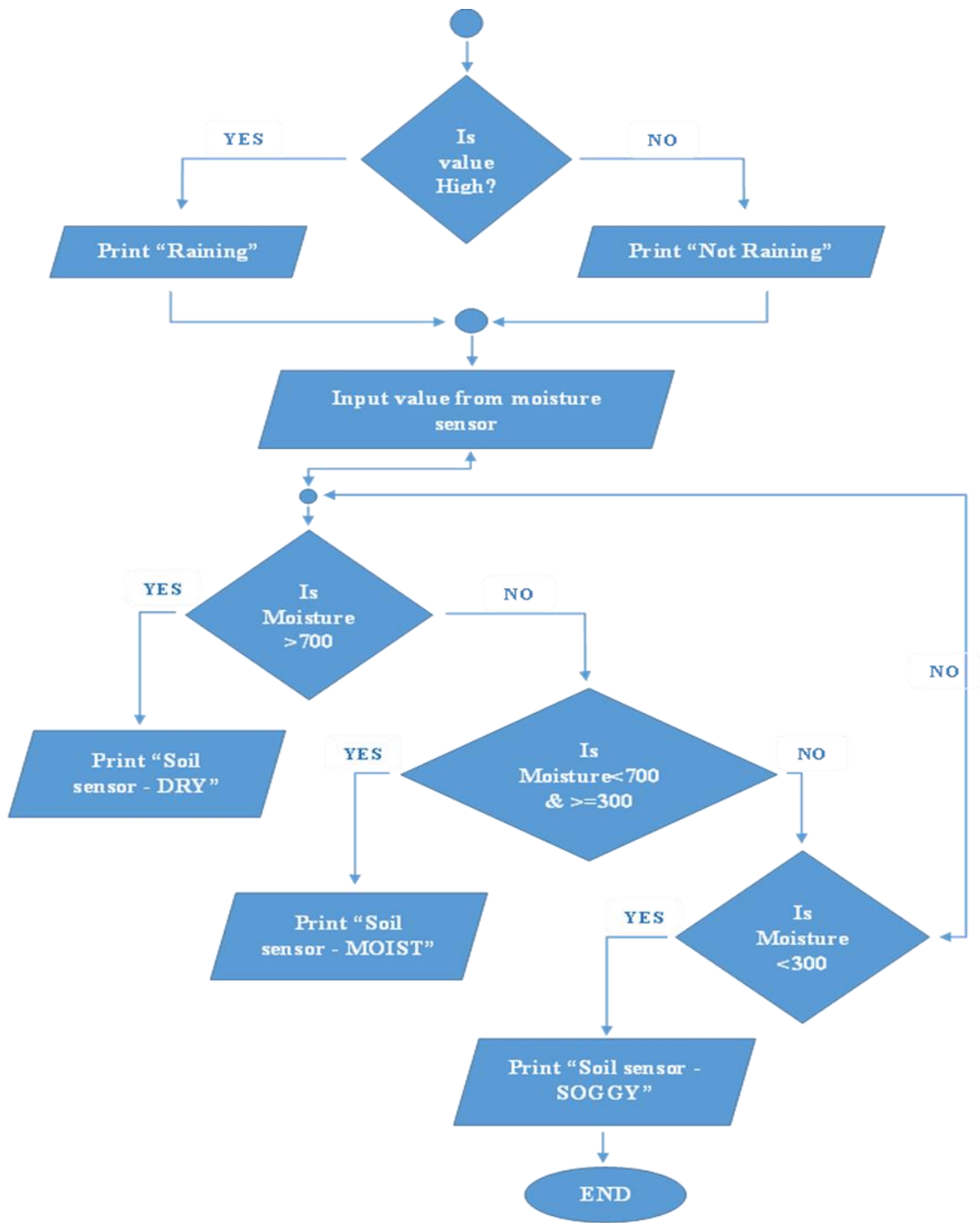

Figure 3.8:-Flowchart of the program for simulation

The flowchart is based on the algorithm of the simulation . Here in the figure it is observed that when the code starts the input interference pin and sensor pins are declared like for example rain=10 . Then the rows and columns of the LCD have been declared inorder to print the system name and sensor values. The program then goes to a if condition , if the temperature sensor gets sensor reading and satisfies the condition it will print the temperature and humidity value but if the condition is not fulfilled then it will show an error . Afterwards the sensor value of the water sensor is taken then many if conditions need to be satisfied. One the basis of each sensor values, after fulfilling the condition the water level can be determined. Similarly, taking readings from rain and soil moisture sensors, if the values fulfill a particular condition then the soil moisture and probability of rain can be seen in the LCD monitor and virtual terminal.

3.5 System Simulation & Setup

3.5.1 System Simulation

The Flood Management and Alarming System is a specific system where the people of the flood-prone zone get an alarming message and instructions before the flood occurs. The simulation of this system demonstrates a virtual environment of the alarming system. A software named Proteus is used in this project in order to demonstrate the whole process in software form. It is therefore a core component and is included with all product configurations .Due to the importance of the project here proteus software is used.

3.5.2 Interfacing Temperature Sensor

The DHT11 is basically Temperature and humidity sensor. The sensor can calculate humidity from 20% to 90% and temperature from 0°C to 50°C. So, for measuring in this range this sensor might be the right choice. The Data pin of the sensor is connected to the A0 pin of the Arduino. The VCC and GND sensor pins are connected to external 5V and GND.

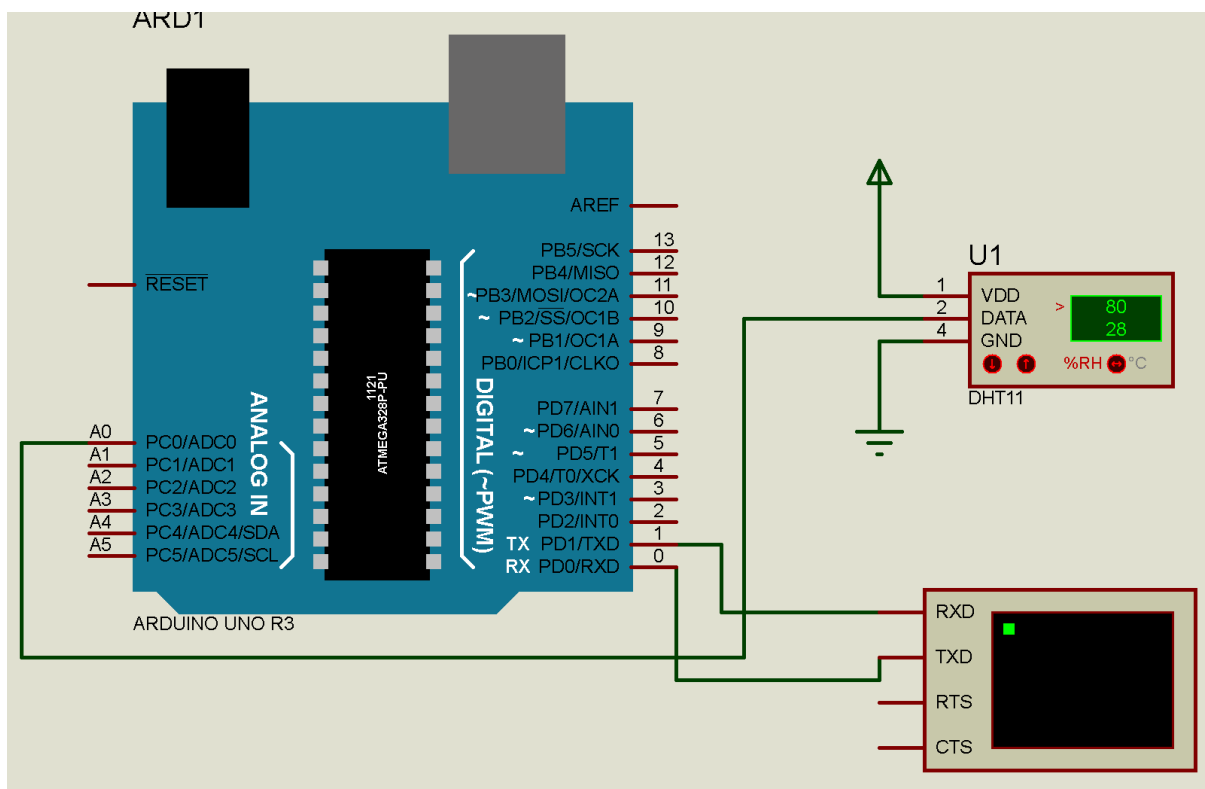

Figure 3.9: - Circuit Diagram of a Temperature Sensor in Proteus.

3.5.3 Interfacing Water Sensor

Water sensors detect the level of liquid layer by layer. The water sensor has many layer if the water exceeds a definite layer then it senses the water level and gives corresponding values. The latter detect the water level levels which are high or low. As water sensor takes analog data from the Ao pin of the arduino and gives sensor data. The VCC pin and GND pin of the sensor are connected to an external 5V source and GND respectively.

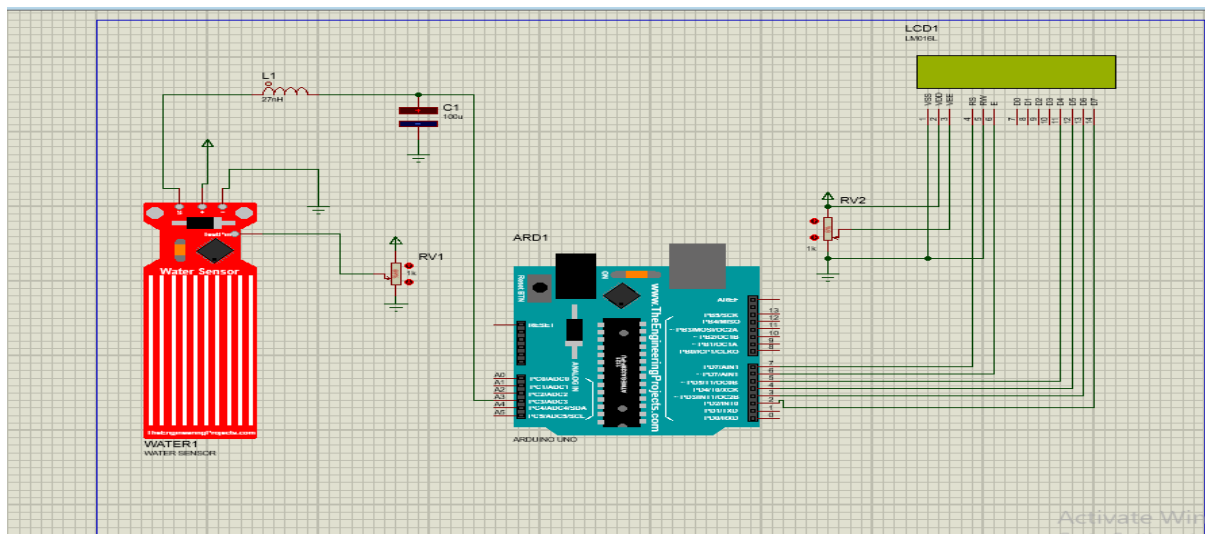

Figure 3.10 : - Circuit Diagram of a Water Sensor in Proteus.

3.5.4 Interfacing Rain Sensor

A rain sensor is one kind of sensor that works as a switch to detect rain .As it works as a switch when it senses rain then it automatically closes switch. The Ao pin of rain sensor is connected to pin12 of the Arduino and an external toggle. When the value of toggle is 1 the simulation will show it is raining, in case of value 0 the situation is vice-versa.

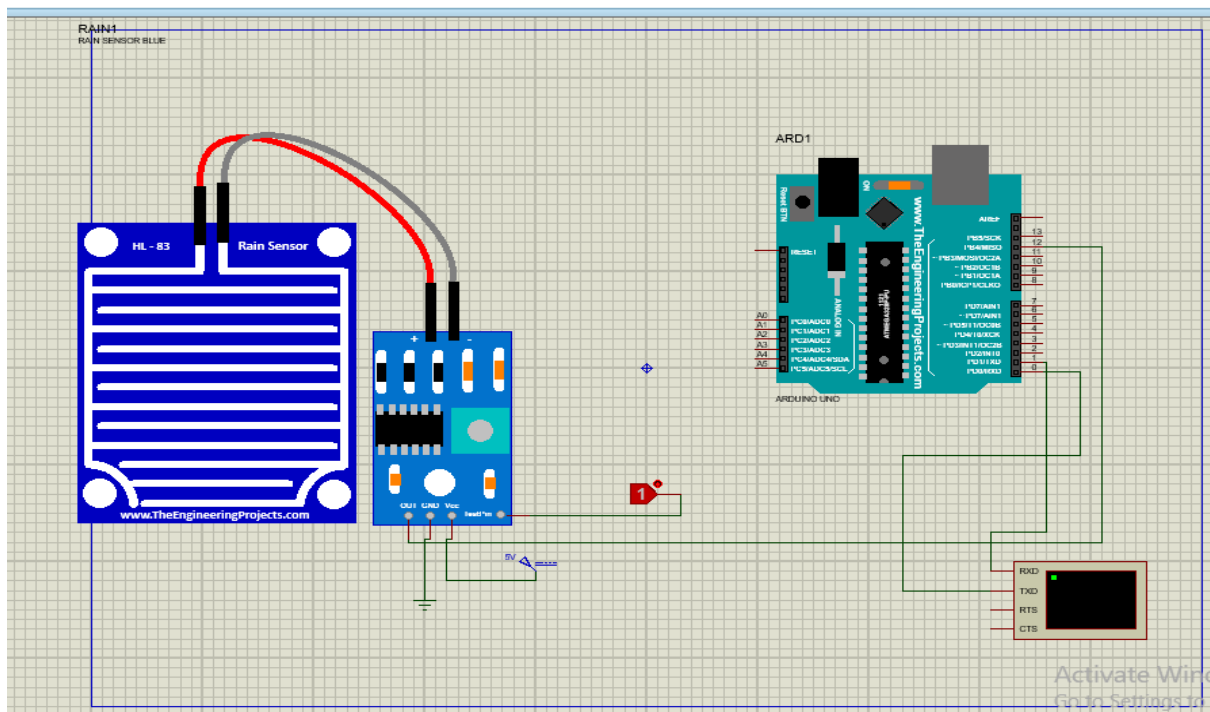

Figure3.11: - Circuit Diagram of Rain Sensor in Proteus.

3.5.5 Interfacing Soil Moisture Sensor

Soil moisture calculates moisture by measuring the water content in soil. The probe of the soil moisture is connected with the analog pin of the Arduino. As soil sensor takes analog data from the Ao pin of the Arduino and gives sensor data. The VCC pin and GND pin of the sensor are connected to an external 5V source and GND respectively.

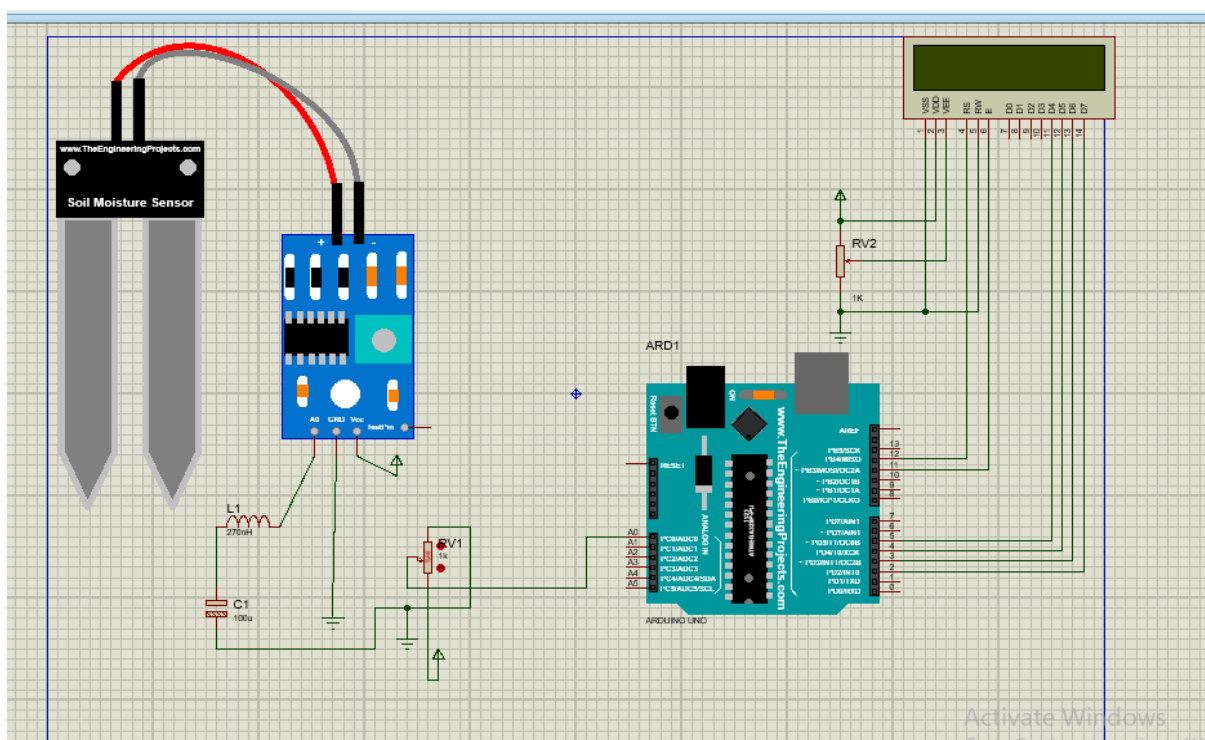

Figure 3.12: - Circuit Diagram of Soil Sensor in Proteus.

3.5.6 Centralized Circuit

We have used Proteus as a simulation platform. Our total circuit consists of four sensors named as water level Detector, rain sensor, soil moisture, temperature sensor (DHT 11) and GSM Module, Arduino. Every sensor is connected through Arduino with specific connections. We have added a library to each sensor separately which eventually added to Arduino. After we

have plotted all sensors to Arduino. The sensors have given the data individually when connected to Arduino through TX pin. The GSM module is connected to RX in Arduino. Then the simulation process has proceeded and we have seen the results through the virtual terminal. At the first virtual terminal all the sensors data has been visualized and at the second virtual terminal we have got the message command of GSM module .All the sensor data changes with the respect to the virtual input.

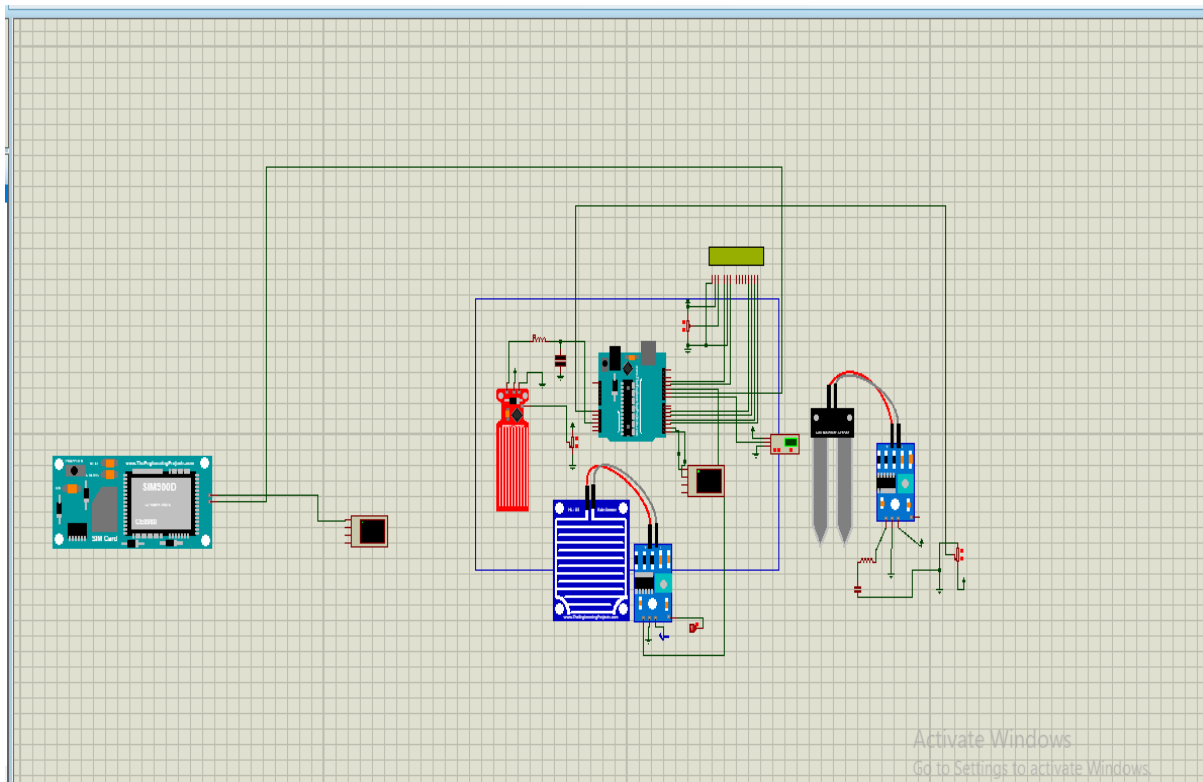

Figure3.13:-Diagram of the Centralized Circuit.

3.6 Hardware Setup

The hardware system consists of temperature sensor, soil moisture sensor, water sensor, Rain sensor, ESP32, and a user interface system named as ThingSpeak, the data pin of the temperature sensor is connected with ESP 32 D21. In Fig:-3.14 The Vcc pin connected to Vin. GND is connected to the GND. After That Rain sensor is connected to the analog pin to D34. The Vcc is connected with Vin and the GND pin is connected with GND of ESP32. In case of water sensor the S pin of the sensor is connected with D35 of ESP32 the analog data of the sensor is transferred to esp through this pin . Vcc and GND are connected to Vin and GND of ESP32. Besides the Ao pin of the soil moisture sensor is connected to ESP32 through D33 and Vcc, GND of the sensor is connected to Vin and Gnd of the NodeMCU. These Sensor datas are imported to Thingspeak cloud server through ESP32 and the graphical representation of the sensor data is observed. In order to get real life data an experimental prototype of embankment is established; the circuit is powered up by Vin. The sensors are placed in different position of the embankment in order to take data from the environment.

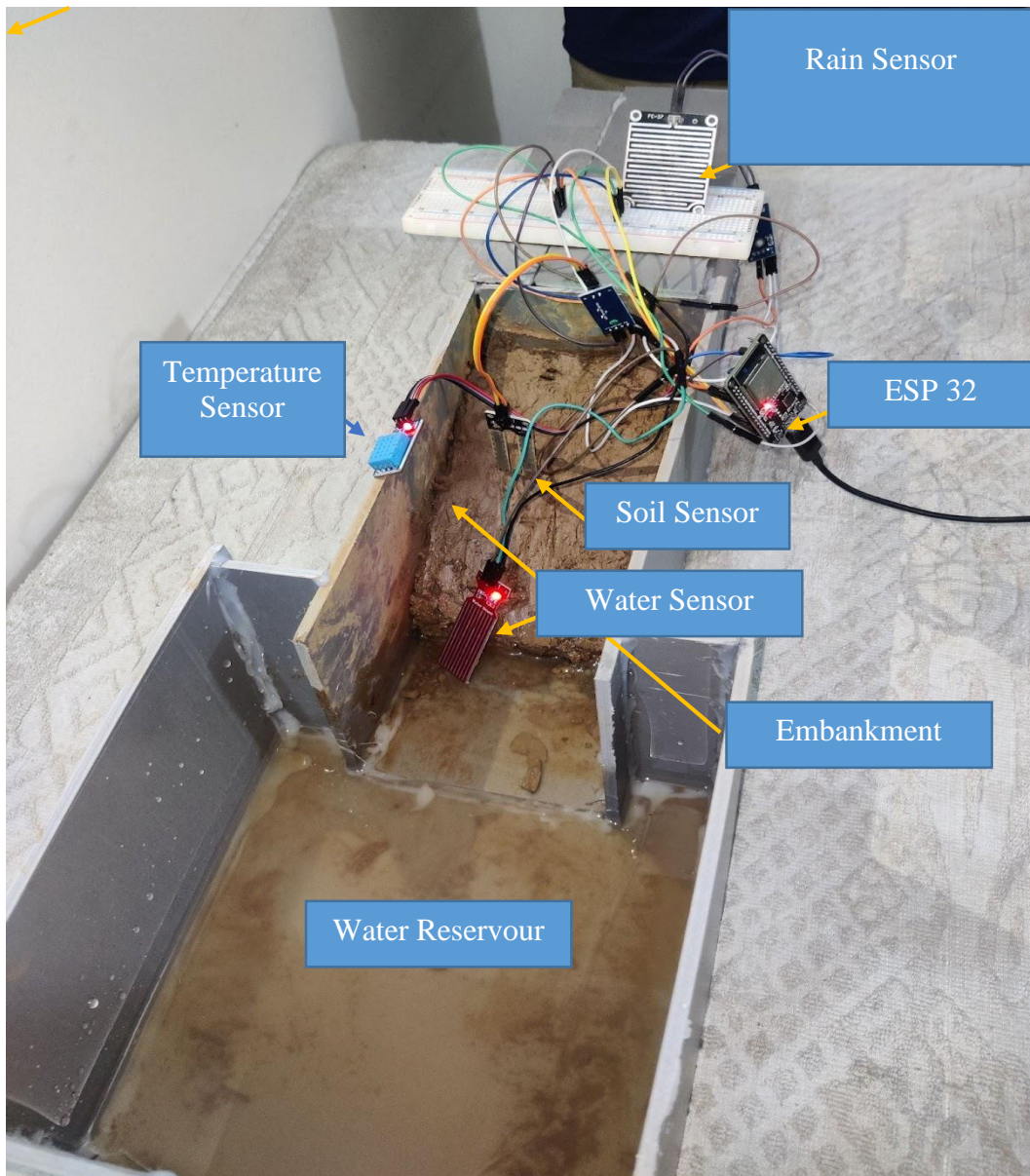

Figure 3.14: - Hardware Setup

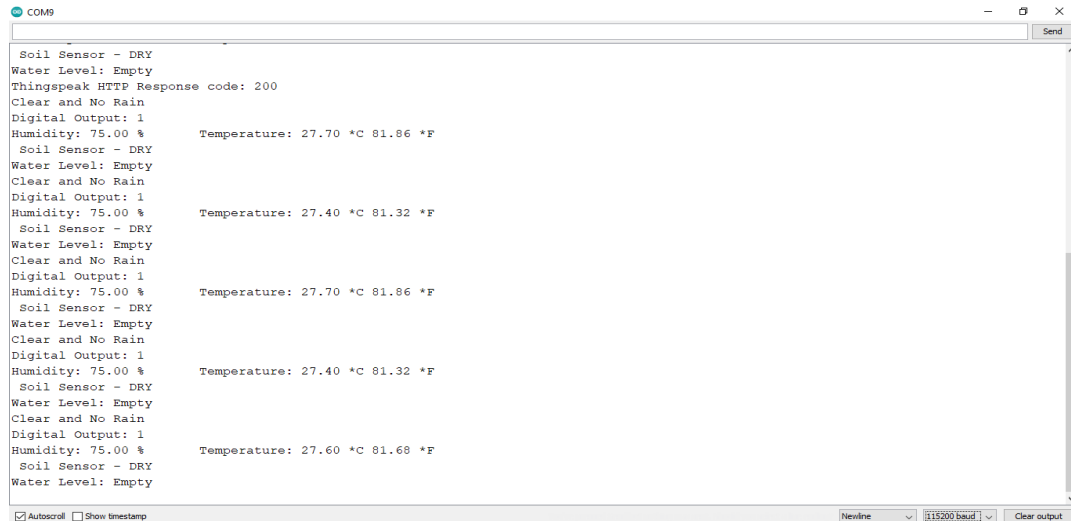

Figure 3.15: - Result after interfacing sensor.

3.7 Methodology

The system is designed to take data on the basis of three cases. These cases are considered on the basis of water level, soil moisture level and rain sensor reading.

3.7.1 Case:-1 (Normal condition)

In case-1, the water level will be low, soil moisture will be dry and there will be no rain. In this case the river flow will be normal then the water level will be low and the embankment will be in good condition.

Table3.5:-Different parameters for Case-1

Parameters	Water Level	Soil Moisture	Rain	Temperature and Humidity
Sensor reading	Low	Dry	Not Raining	From DHT11 sensor
Sensor value	Sensor Value<300	Sensor value<20	1	From DHT11 sensor

3.7.2 Case:-2 (Moderate Condition)

In case-2, the water level will be medium, soil moisture will be soggy and it will rain. In this case the river flow will increase then the water level will be medium and the embankment will act as a support against the high river flow.

Table3.6:-Different parameters for Case-2

Parameters	Water Level	Soil Moisture	Rain	Temperature and Humidity
Sensor reading	Medium	Soggy	Raining	From DHT11 sensor
Sensor value	Sensor value<500	20<Sensor value<30	0	From DHT11 sensor

3.7.3 Case:-3 (Critical Condition)

In case-3, the water level will be high, soil moisture will be extremely soggy and it will rain heavily. In this case the river flow will increase extremely then the water level will be extremely high and the embankment will be in critical condition against the high river flow .In this case the embankment may collapse anytime so the inhabitants will be notified with a message alert.

Table3.7:-Different parameters for Case-3

Parameters	Water Level	Soil Moisture	Rain	Temperature and Humidity
Sensor reading	High	Extremely Soggy	Heavy Rain	From DHT11 sensor
Sensor Range value	Sensor value>500	Sensor value>30	0	From DHT11 sensor

By taking all the sensor data from these conditions the data is uploaded to the user interface system, Thingspeak. From the thingspeak the graph is generated in order to analyze the situation of embankment in these three situations. By analyzing these conditions the embankment is monitored and when the embankment is in critical condition the warning is activated and an emergency message is navigated to the inhabitants for minimizing extensive damage because of flood.

Chapter 4

Results Analysis & Discussion

In this section, the overall system outcome is analyzed and compared briefly. The system generates real life data from the sensors .Esp32 receives all the data and uploads to the Wi-Fi server of Thingspeak. The graphical representation of the data is generated by Thingspeak .Firstly in this chapter the graphical representation of temperature, rain, water and soil moisture sensors are analyzed on the basis of the data collected for a rigid interval of time. Afterwards a comparison presentation is on the next graphs are based on three cases which have been considered for embankment prototype. Finally the simulation output of the total system is analyzed. The overall section demonstrates the graphical representation and analysis of the graph.

4.1 Observing the sensors data

Thingspeak generates a graph for each sensor on the basis of the real life data from the sensor.

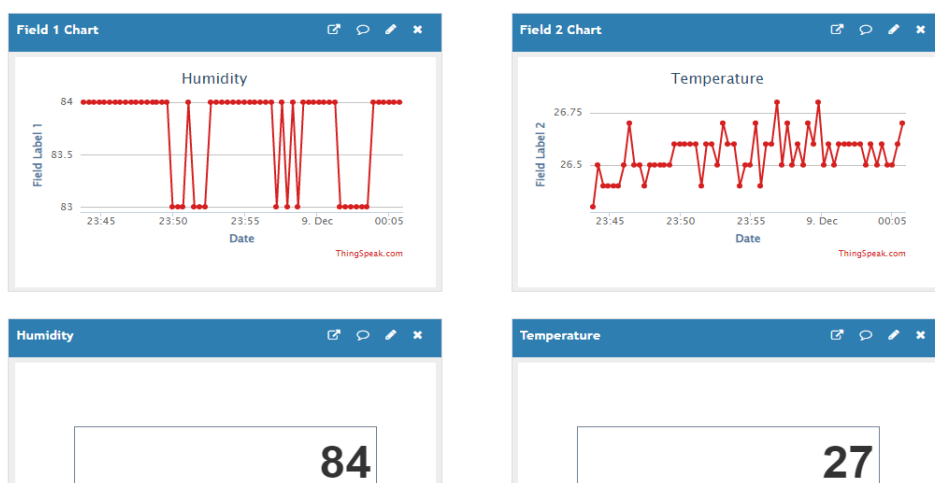

Figure 4.1: - Graphical representation temperature sensor from thingspeak.

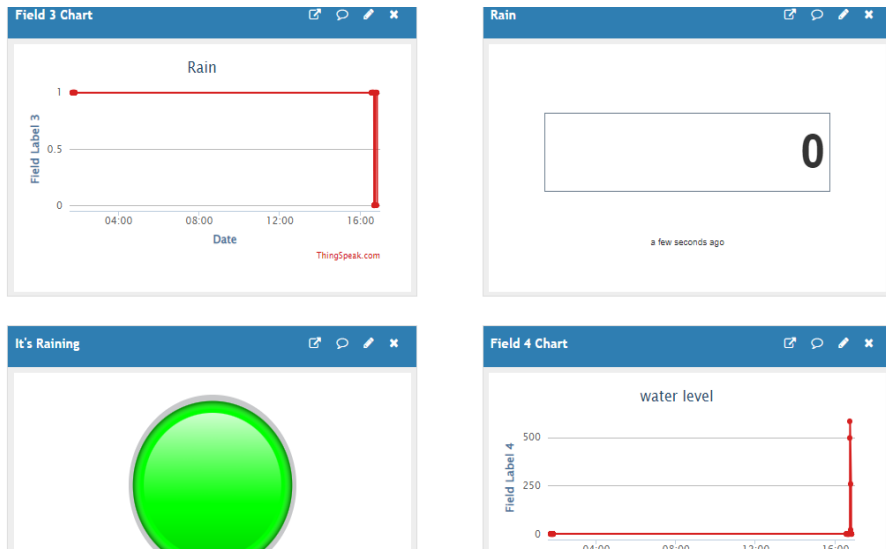

Figure 4.2: - Graphical representation of rain and water level sensor from thingspeak

When the rain sensor gives 0 value the green light is lightened which means it is raining. Here the value has been set to less than 1 . If the sensor value is less than 1 then the green light will be visualized.

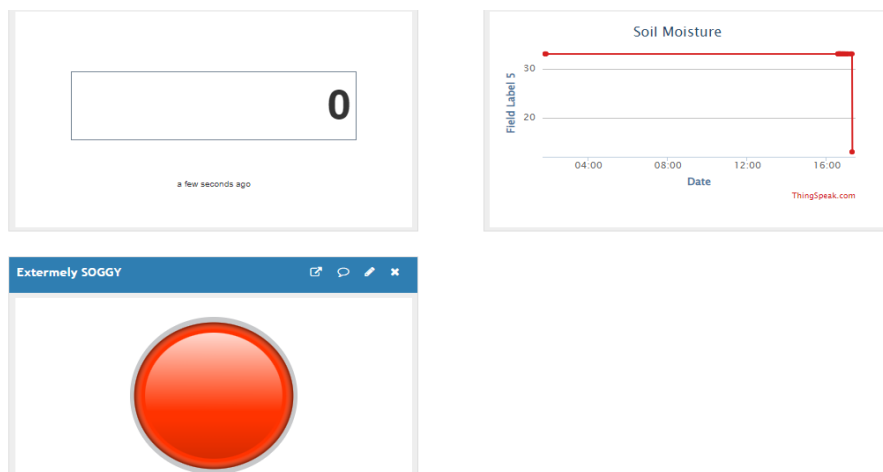

Figure 4.3:- Graphical representation of soil moisture sensor from thingspeak

When the soil moisture increases greater than the critical value then the red light becomes visible .

Temperature sensor: -

In the case of a temperature sensor, the sensor data has been taken for a couple of days. The data is plotted in order to generate a line diagram. The Fig. 4.4 shows the plot of temperature sensor data which has been taken from 7th December to 8th December. From the graph it is observed that temperature sensor data fluctuates with respect to time. It shows the temperature of the test bed (embankment) varies 23 to 28 degrees Celsius. Similarly, Fig. 4.5 shows the humidity sensor data for the same days. As it is a winter season, the humidity varies for the different portion of the day. It is evident that humidity rises at the late night and remains stable up to the morning. At the beginning of the morning it starts to fall.

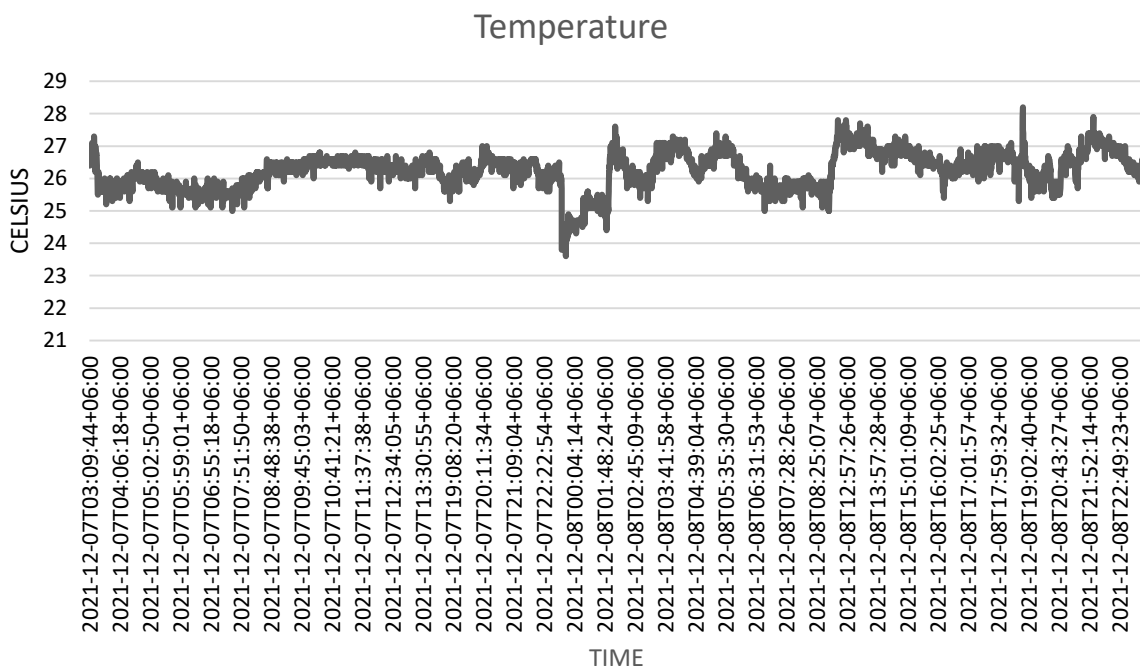

Figure 4.4: - Plot of Temperature Sensor; Data taken on 7 – 8 December 2021.

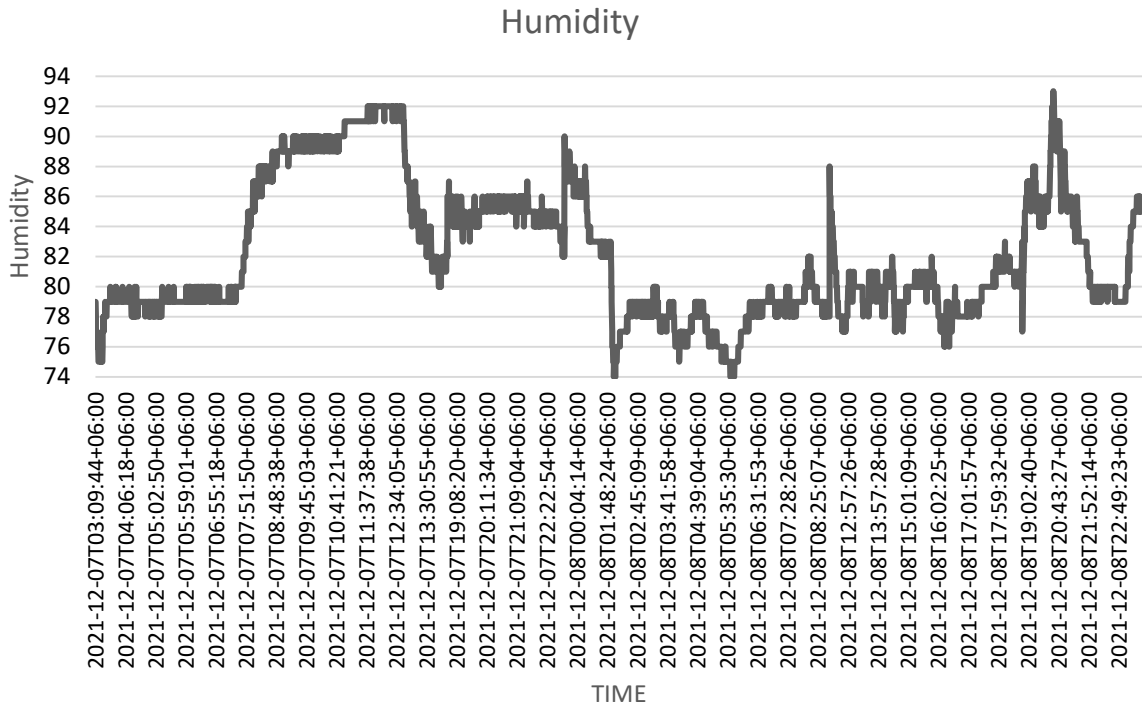

Figure 4.5; - Plot of Humidity Sensor; Data taken on 7 – 8 December 2021

Rain sensor: -

In Fig-4.6 the rain sensor gives digital data so the graph plot of the rain sensor represents the sensor value 0 or 1. The rain is simulated for a particular time. As the prototype is in house condition. From the graph we can see that the points where the value is 0 represent “it is raining “. On the other hand, the points where the value is 1 represents “not raining”. The interval of time where the value of the sensor is 0 then it represents that there is a probability of a flood happening if this time interval is more than usual. So in Fig;-4.3 shows there was rain in between 8th December 19:05 to 21:14 pm. This data has been collected from the situation created artificially. Here water is given to rain sensor to sense rain.

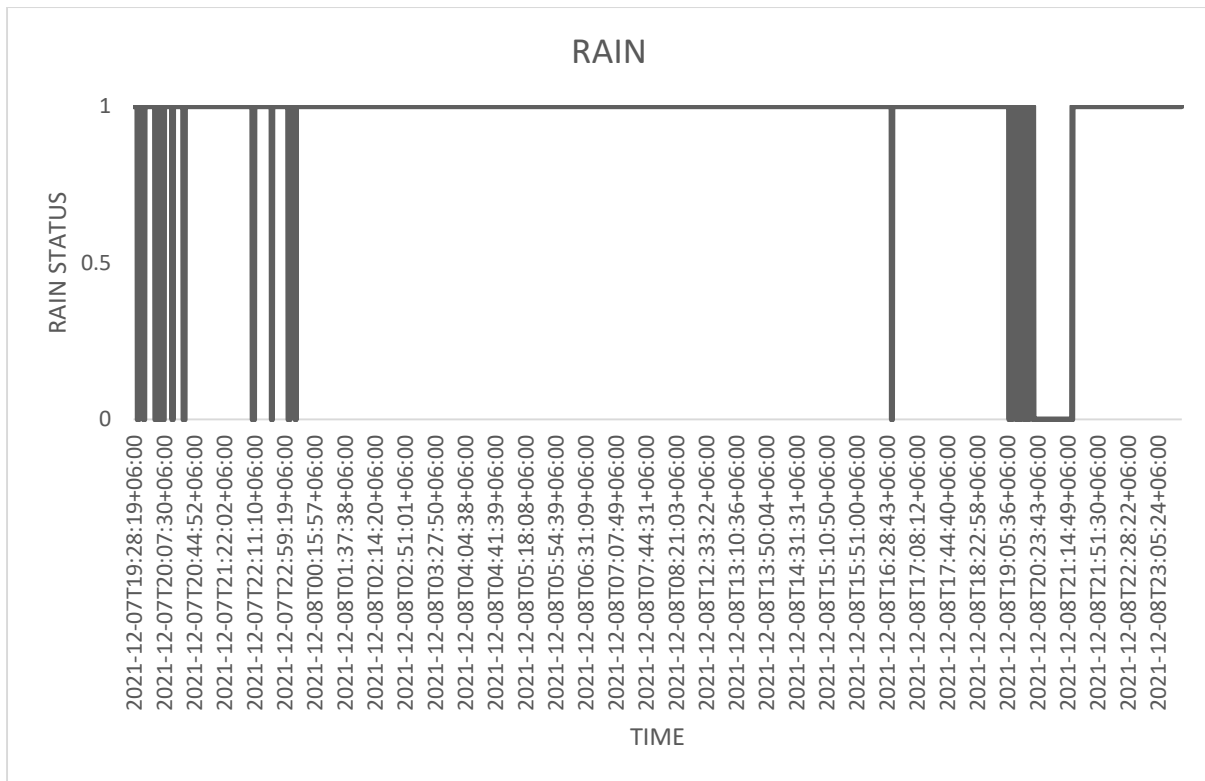

Figure 4.6- Plot of Rain Sensor - Data taken on 7 – 8 December 2021.

Water level Sensor:-

This water level sensor gives data from 0 to 800. If the value of water sensor is less than 300, the water level is low and if it is less than 500, the water level is medium and for values greater than 500 water level is high. The graph plot of the water level sensor will be a line graph and it will fluctuate with respect to time and gives frequent data. From the graph it is observed that when the water level is high the graph moves upwards and gives high sensor value. In other situations when the water level decreases the graph goes downward. This water sensor value is taken by planting water sensor in an embankment prototype artificially.

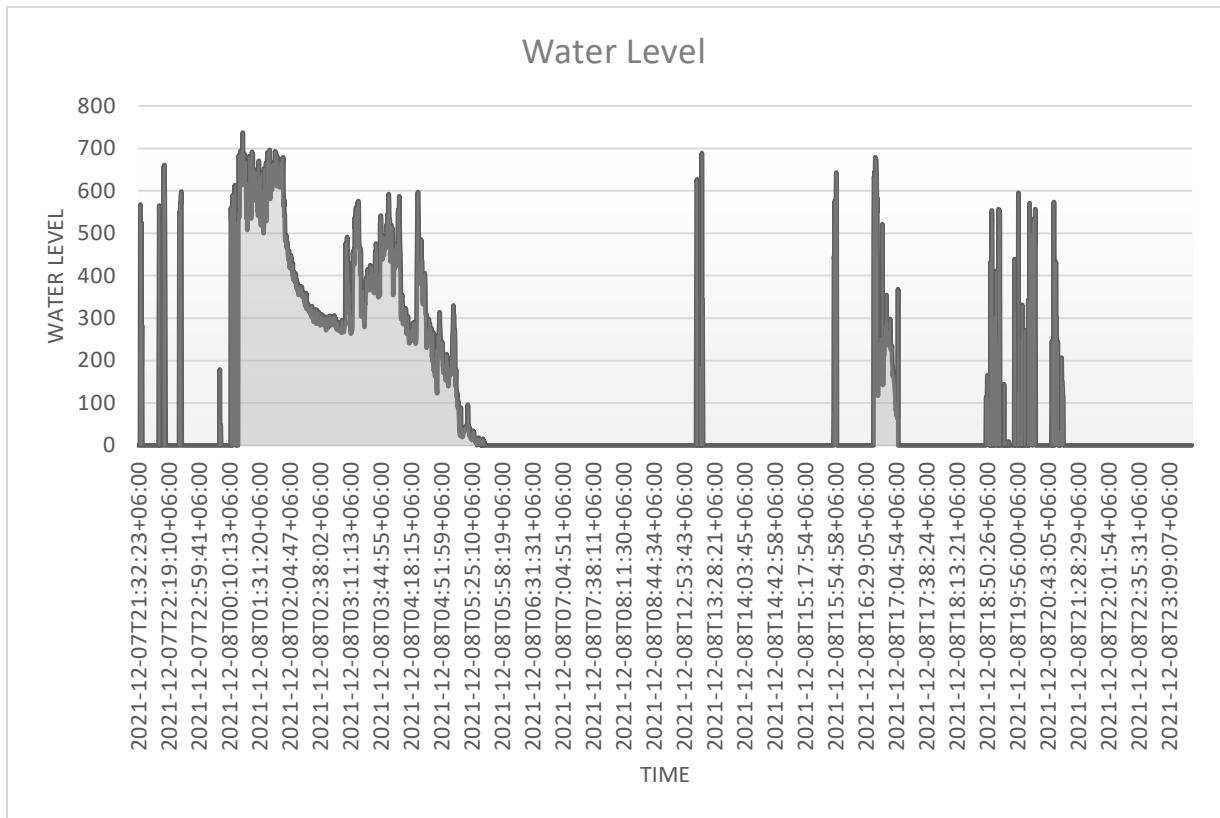

Figure 4.7:- Plot of Water Level Sensor; Data taken on 7 – 8 December 2021.

From the Fig;-4.7 it is observed that when the water level is high the graph moves upwards and gives high sensor value. In other situations when the water level decreases the graph goes downward.

Soil sensor:-

The soil moisture sensor gives data on the basis of moisture level .So the graph of soil moisture will differ in different moisture levels.

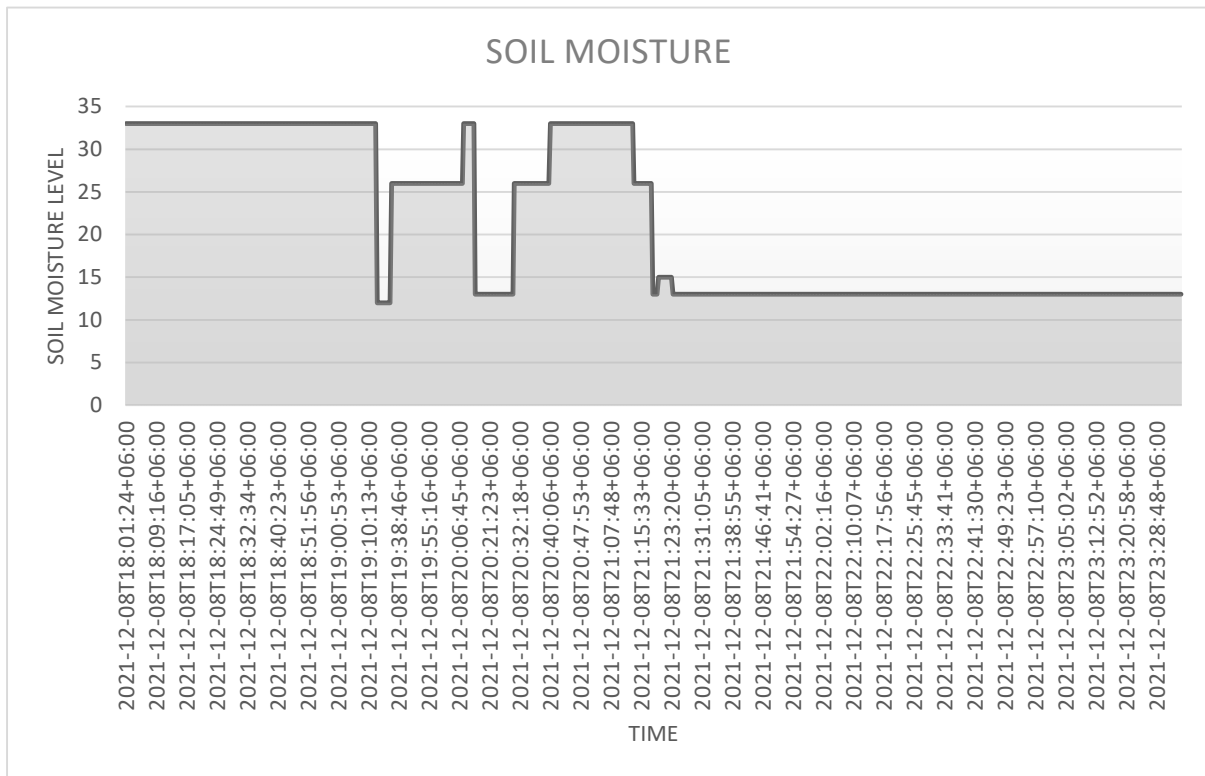

Figure 4.8- Plot of Soil Moisture Sensor; Data taken on 8 December 2021.

From Fig;-4.8 we can see that when the soil moisture level is low it is in dry condition and when the moisture level is moderate the graph moves slightly upward. In case of maximum moisture level the graph retains a particular value, it represents that the soil moisture is soggy. If the value of soil moisture sensor is less than 20, the soil moisture is dry and if it is in between 20 and 30 , the water level is soggy and for values greater than 30 then soil moisture is extremely soggy. Soil moisture is placed in the soil of the embankment to take all the data artificially.

4.2 Graphical Analysis of Sensor data in different condition

4.2.1 Sensor Reading for Normal Conditions:-

In this case, the water level will be low, soil moisture will be dry and there will be no rain. At 7:10 pm taking conditions for case-1 the test was performed.

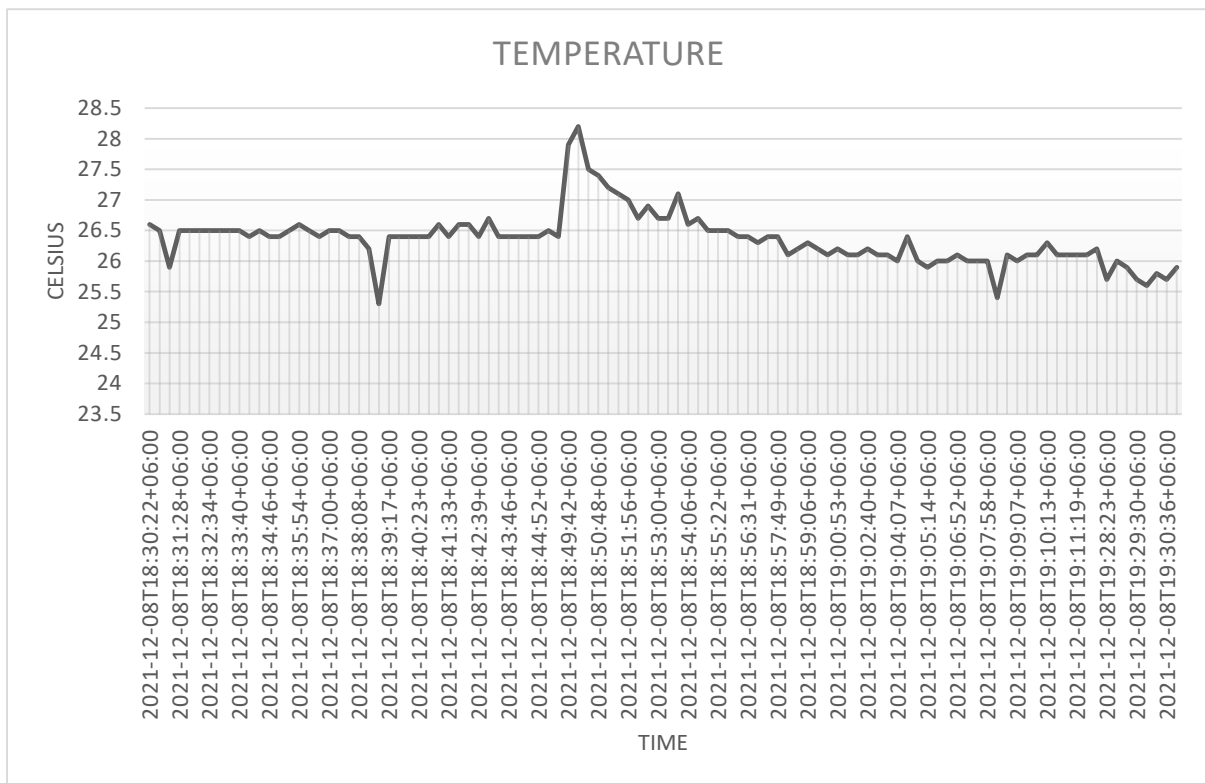

Figure 4.9:- Plot of Temperature Sensor; Data taken for Normal Conditions.

Temperature sensor graph fluctuates with the increase of temperature with time. For case-1 in Fig:-4.9 the temperature at 7:10 pm is 25.7 degree celsius. At 7:10 pm the case -1 condition is demonstrated in order to get sensor data. In This condition the temperature and humidity sensor will show temperature and humidity which indicates a good weather .

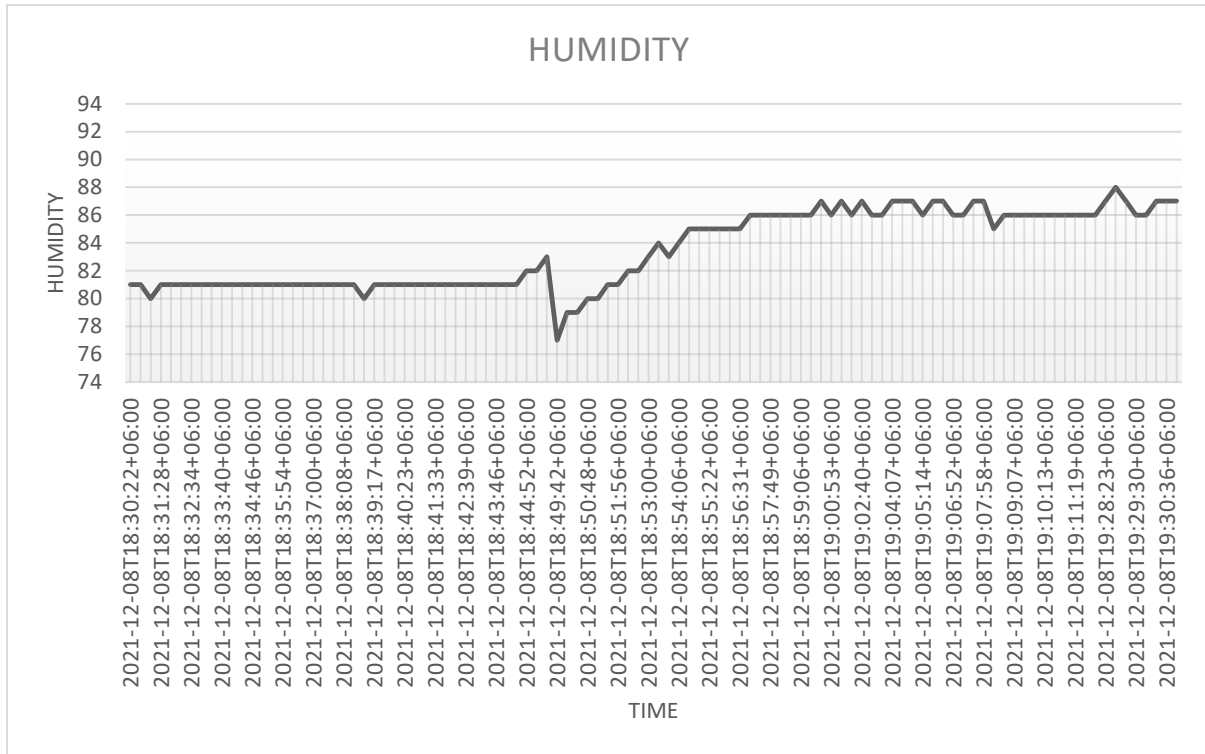

Figure 4.10:- Plot of Humidity Sensor; Data taken for Normal Conditions.

Humidity in Fig:-4.10 is indicated as percentage so the value of the humidity sensor will be as percentage. This case is performed at 7:10 pm, the humidity sensor gives the value which is 79 .The graph moves with respect to time. That means the humidity value of the temperature and humidity sensor is 79 percent.

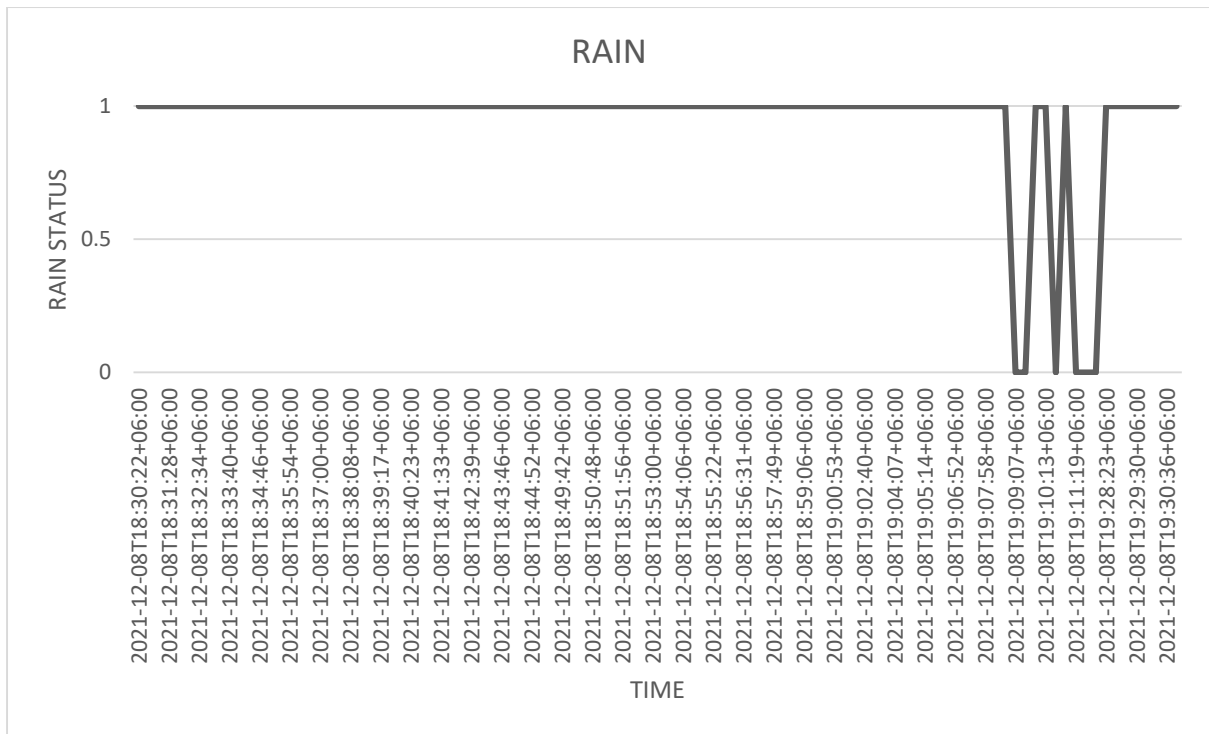

Figure 4.11:- Plot of Rain Sensor; Data taken for Normal Conditions.

From Fig:-4.11 we can see that at 7.10 pm there was no rain ,as the rain sensor gives the digital output (1 or 0) so in this case the rain sensor will show that it's not raining . The interval of time where the value of the sensor is 0 then it represents that there is a probability of a flood happening if this time interval is more than usual. This data has been collected from the situation created artificially. Here water is given to rain sensor to sense rain.

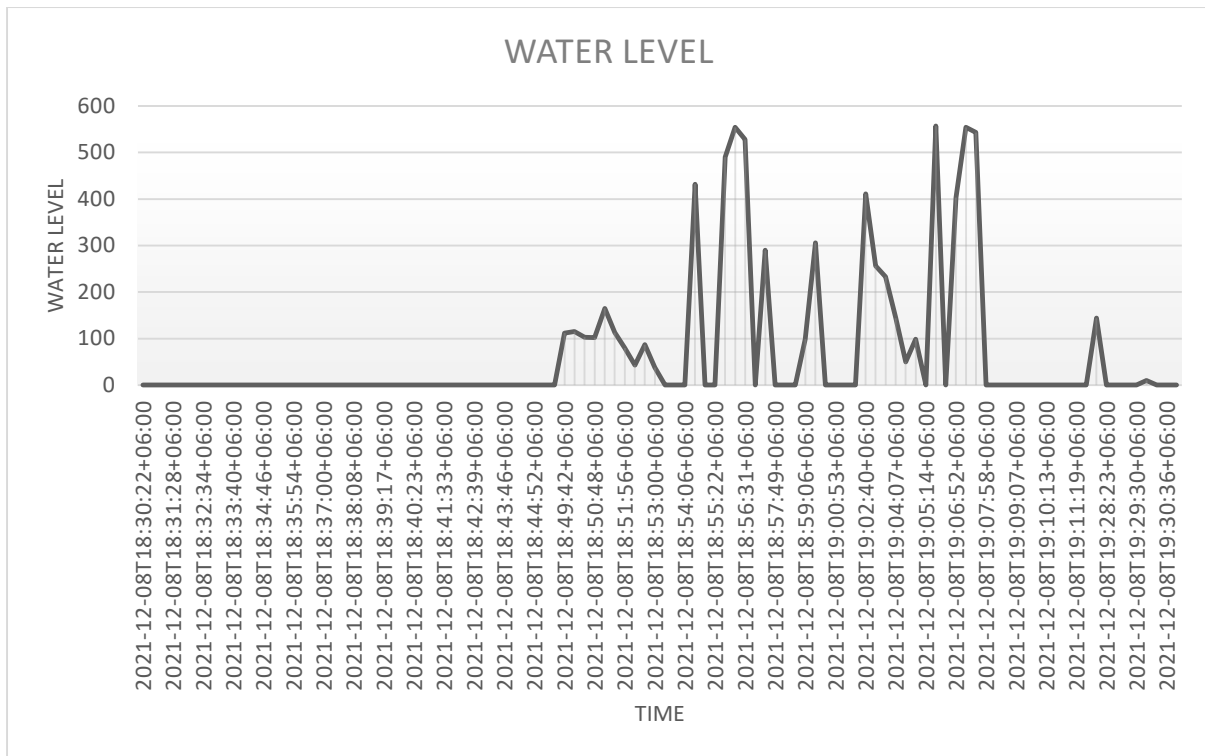

Figure 4.12:- Plot of Water Sensor; Data taken for Normal Conditions.

From Fig:-4.12 at 7.10 pm the water level was low. So for case-1 from the graph we can see that the water level sensor value is less than 300. So the water level sensor demonstrates the desired value for case-1. This water level sensor gives data from 0 to 800. If the value of water sensor is less than 300, the water level is low and if it is less than 500, the water level is medium and for values greater than 500 water level is high. So in this case the water level at 7:10 pm was low. This water sensor value is taken by planting water sensor in an embankment prototype artificially.

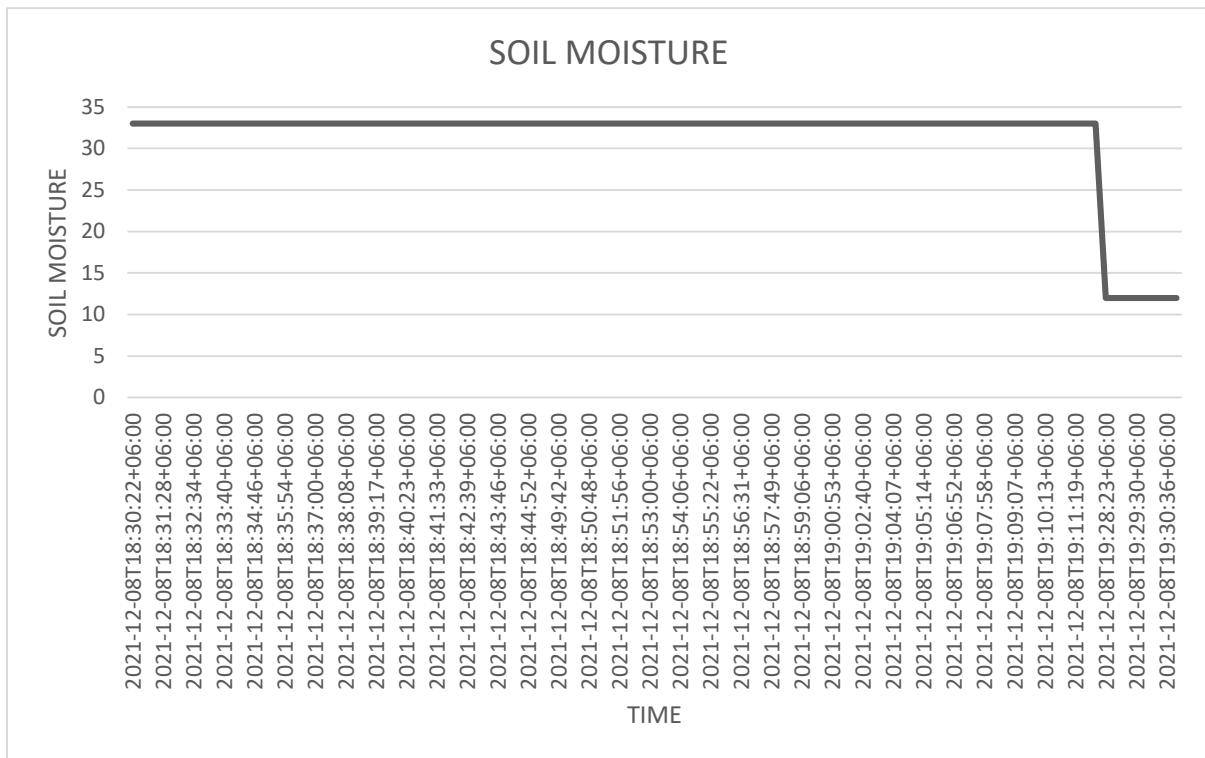

Figure 4.13:- Plot of Soil Moisture Sensor; Data taken for Normal Conditions.

In Fig:-4.13 the soil moisture sensor value from the graph is less than 20. So according to the condition, the sensor will show “Dry” at 7:10 pm. If the value of soil moisture sensor is less than 20, the soil moisture is dry and if it is in between 20 and 30, the water level is soggy and for values greater than 30 then soil moisture is extremely soggy. In this case at 7:10 pm the value is less than 20 so the moisture level is low. Soil moisture is placed in the soil of the embankment to take all the data artificially.

4.2.2 Sensor Reading for Moderate scenario

In this case, the water level will be medium, soil moisture will be soggy and it will rain. At pm by considering all the conditions for this case the test was performed.

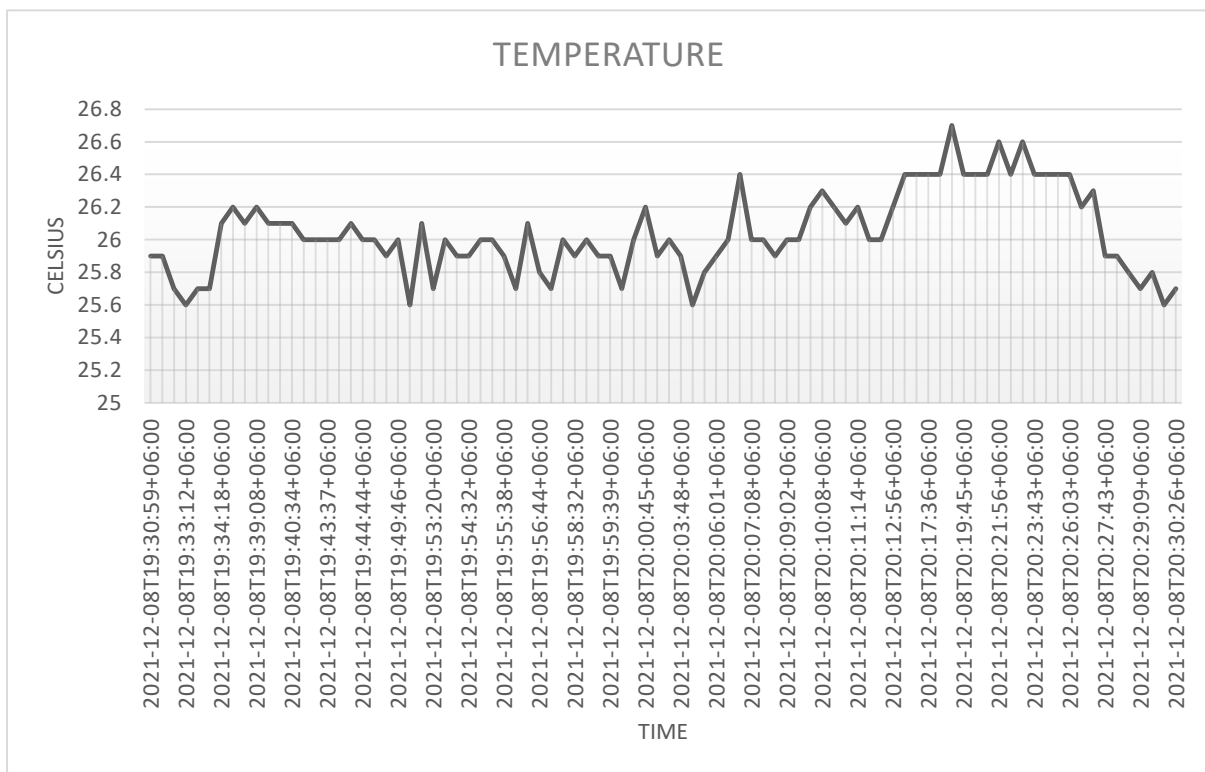

Figure 4.14:- Plot of Temperature Sensor; Data taken for Moderate Conditions.

From Fig:-4.14 we can see that at 7:51 pm the temperature sensor gives 25.6 degree celsius . So this value fulfills the conditions for case-2 and rain occurs. Here the temperature changes with respect to time

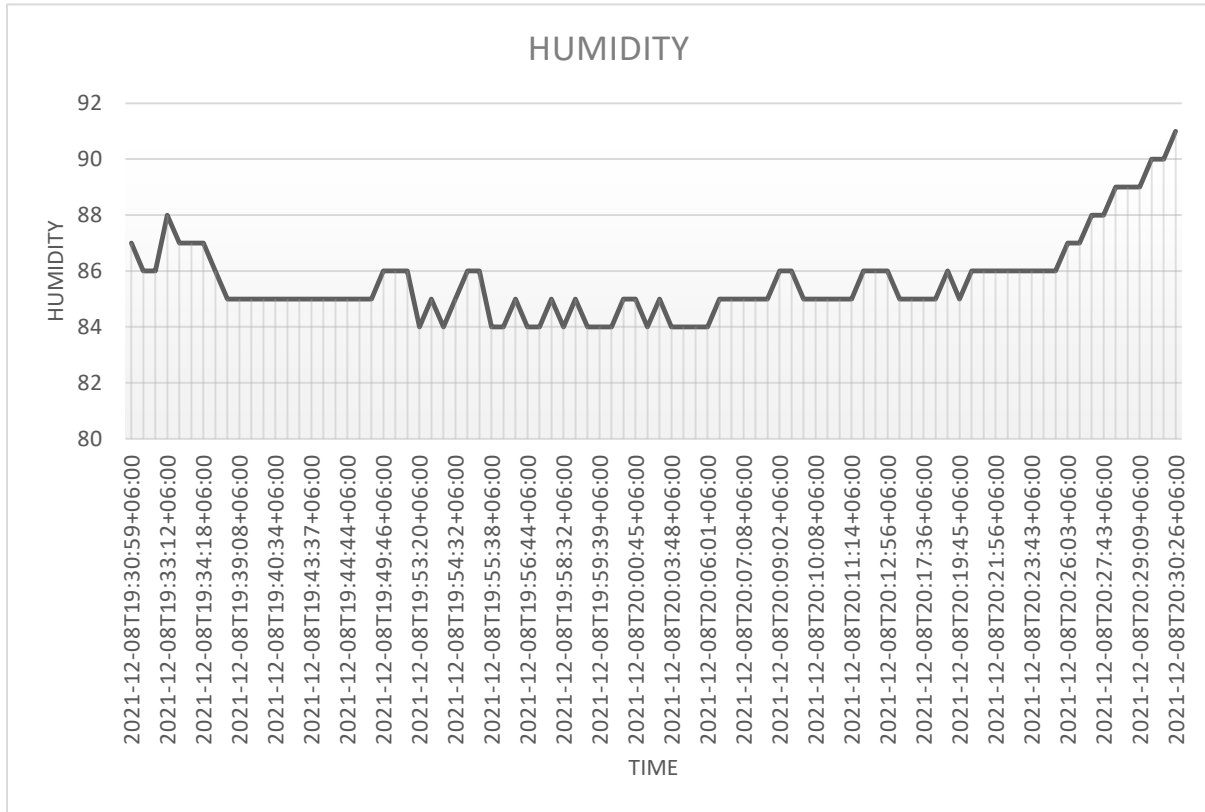

Figure 4.15:- Plot of Humidity Sensor; Data taken for Moderate Conditions.

From Fig:-4.15 the humidity sensor gives value. So at 7:51 pm the humidity sensor gives a value which gives an assumption that it is raining. Here the humidity graph changes with time. That means the humidity value of the temperature and humidity sensor is represented in percent.

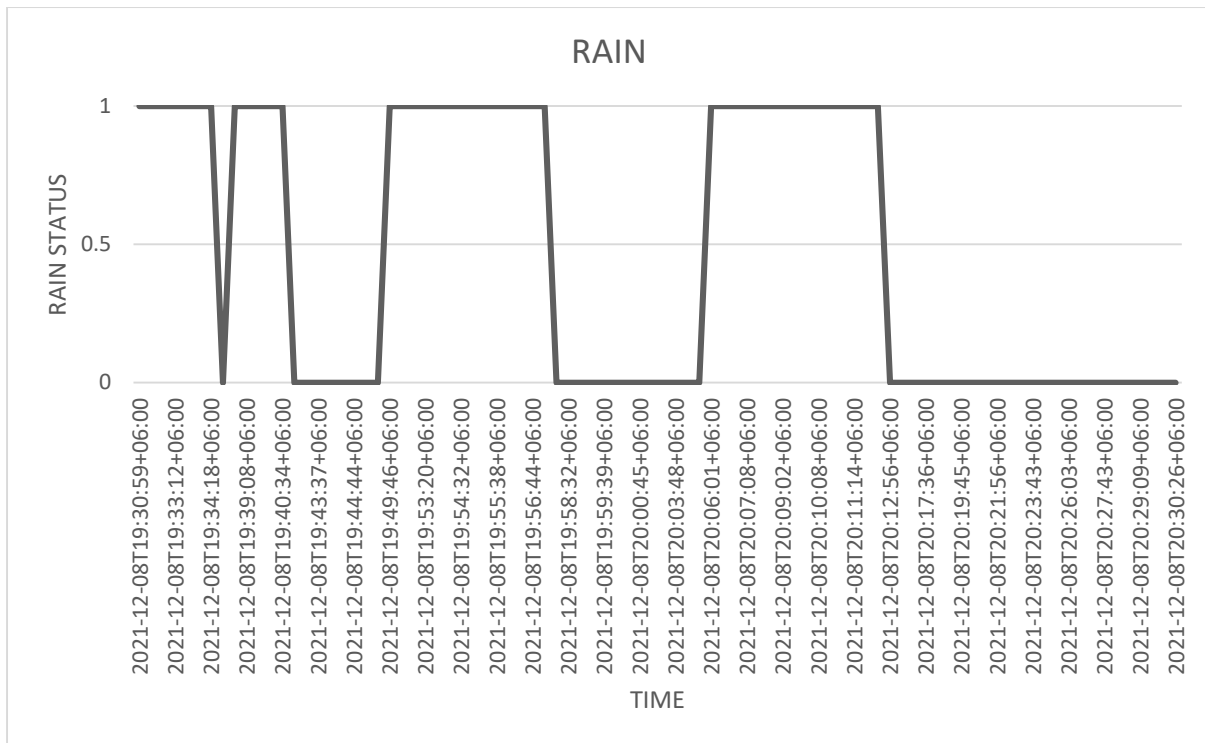

Figure 4.16:- Plot of Rain Sensor; Data taken for Moderate Conditions.

From the Fig:-4.16 we can see that at 7:51 pm the rain sensor value rises up from 0 to 1, which indicates the rain stopped at around 7:51 pm. Before 7:51 pm the graph shows the sensor value 0 which means it had been raining before that time. So due to the previous rain the water level increases and soil moisture becomes soggy. The rain sensor value fulfills the condition for case-2. This data has been collected from the situation created artificially. Here water is given to rain sensor to sense rain.

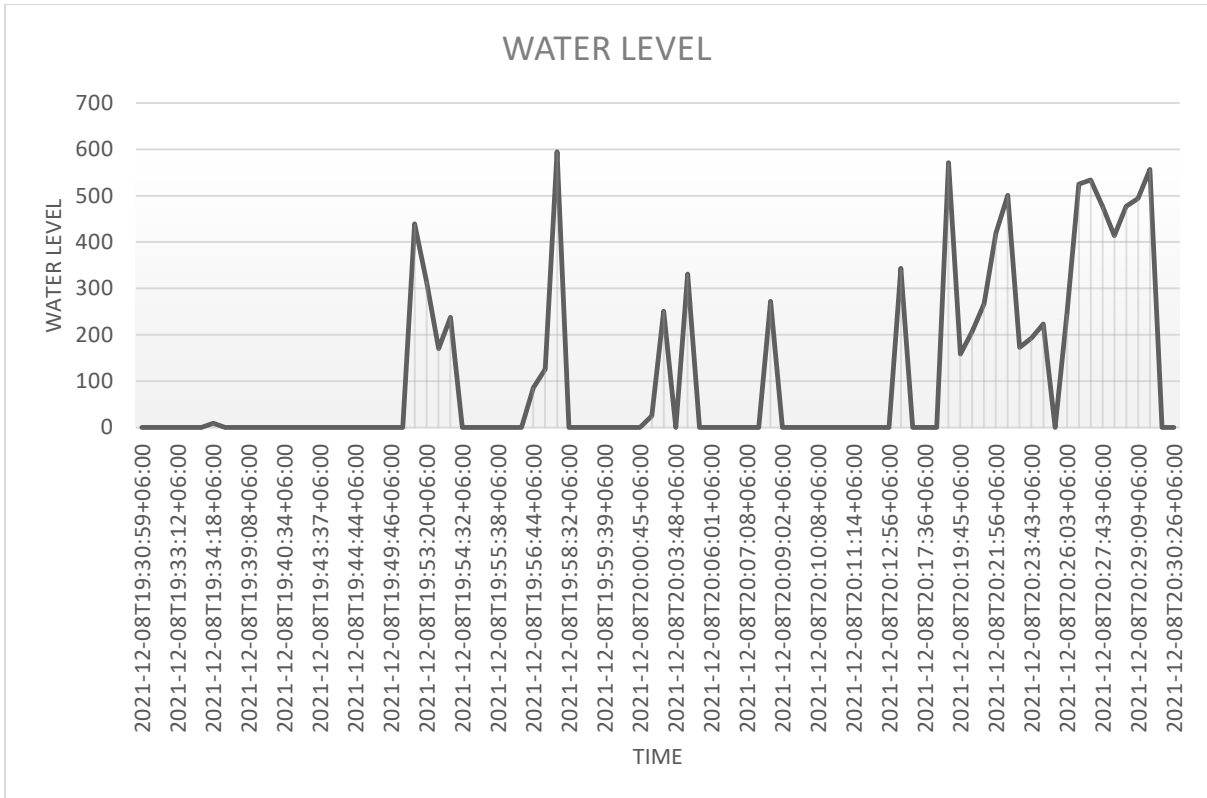

Figure 4.17:- Plot of Water Sensor; Data taken for Moderate Conditions.

From Fig;-4.17 it is noted that at 7:51 pm the water level sensor gives a value less than 500. So as per conditions the sensor will show water level medium. This water level sensor gives data from 0 to 800. If the value of water sensor is less than 300, the water level is low and if it is less than 500, the water level is medium and for values greater than 500 water level is high. So at 7:51 pm the water level is medium . This water sensor value is taken by planting water sensor in an embankment prototype artificially.

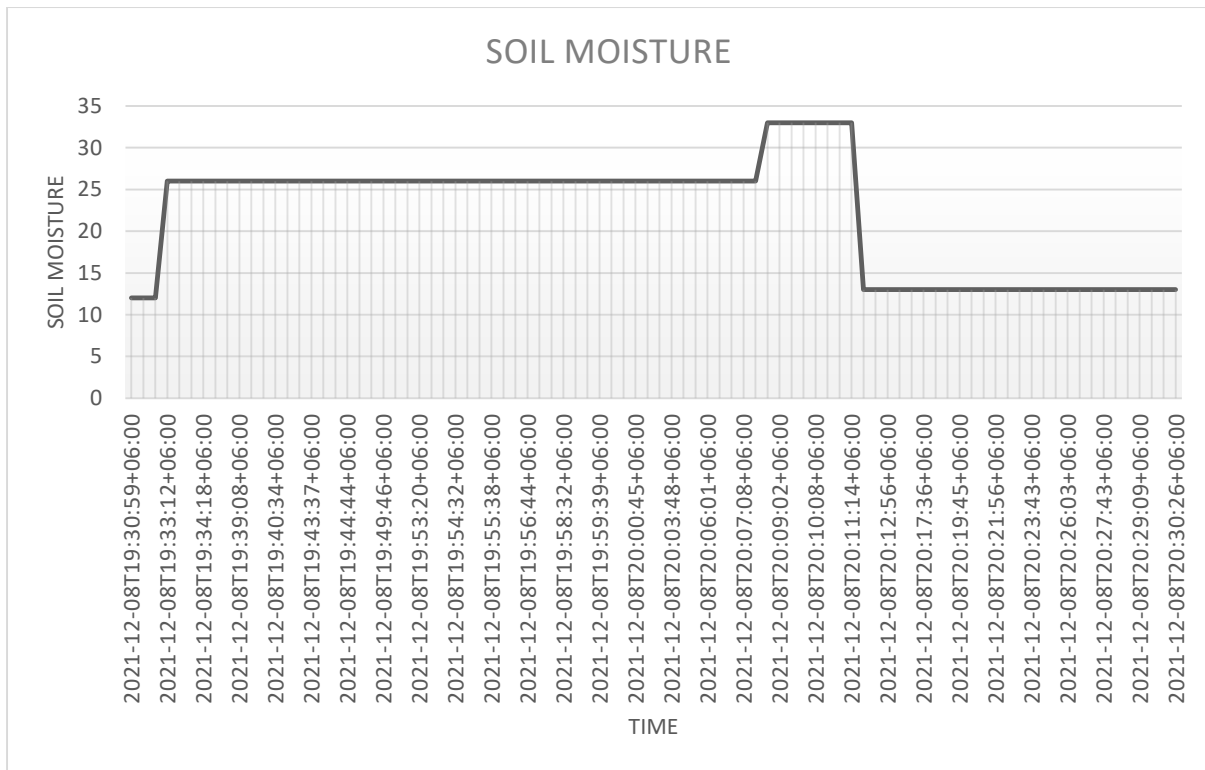

Figure 4.18:- Plot of Soil Moisture Sensor; Data taken for Moderate Conditions.

From Fig:-4.18 it is observed that at 7:51 pm soil moisture sensor value is greater than 20 and less than 30 . So the soil moisture will show soggy and the conditions for the case:-2 are maintained . Soil moisture is placed in the soil of the embankment to take all the data artificially.

4.2.3 Sensor Reading for Critical Scenario

In critical scenarios, the water level will be extremely high , soil moisture will be extremely soggy and it will rain heavily . For this condition test had been initiated at 9: 02 pm and all the sensor values for this condition were recorded .

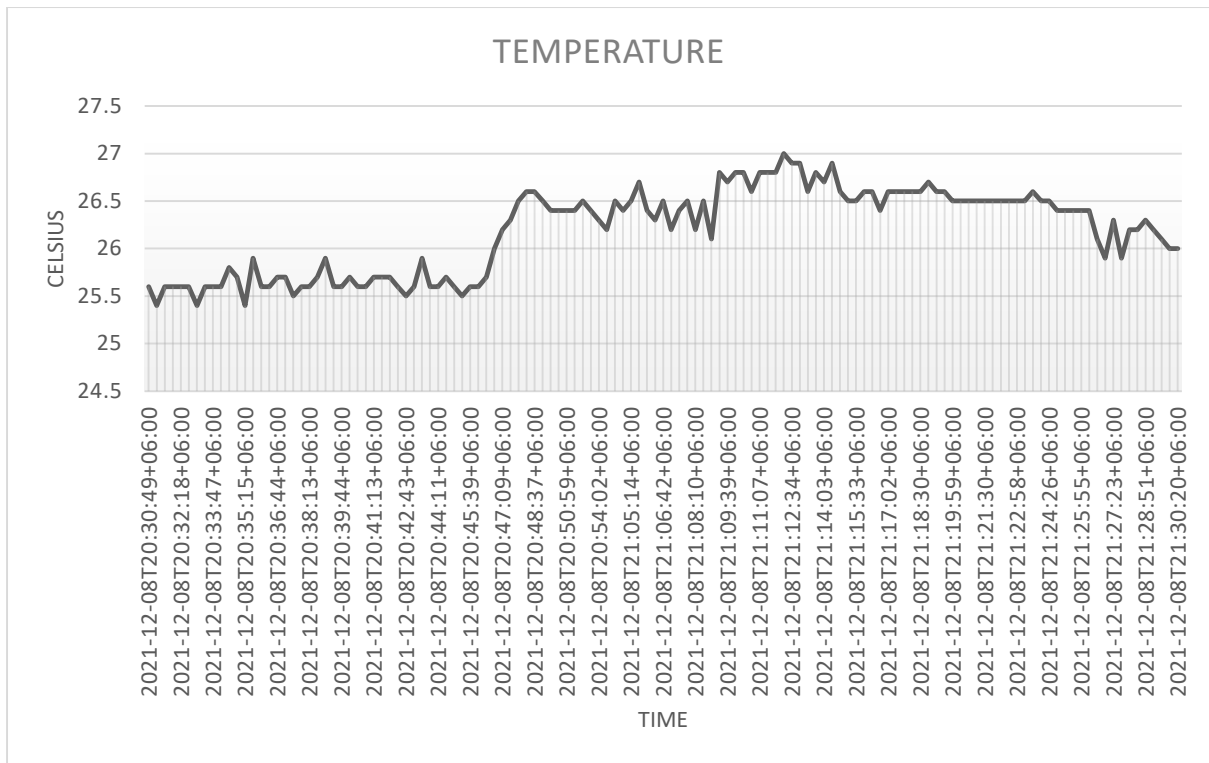

Figure 4.19:- Plot of Temperature Sensor; Data taken for Critical Conditions.

From the Fig;-4.19 it is clear that the temperature sensor gives output of 26.2 Degree Celsius. So in this condition extensive rain may occur. So for the condition of critical scenario temperature sensor gives correct reading. This graph changes with time so as the temperature is comparatively low so it indicates there will be rain and satisfies the conditions for case-3.

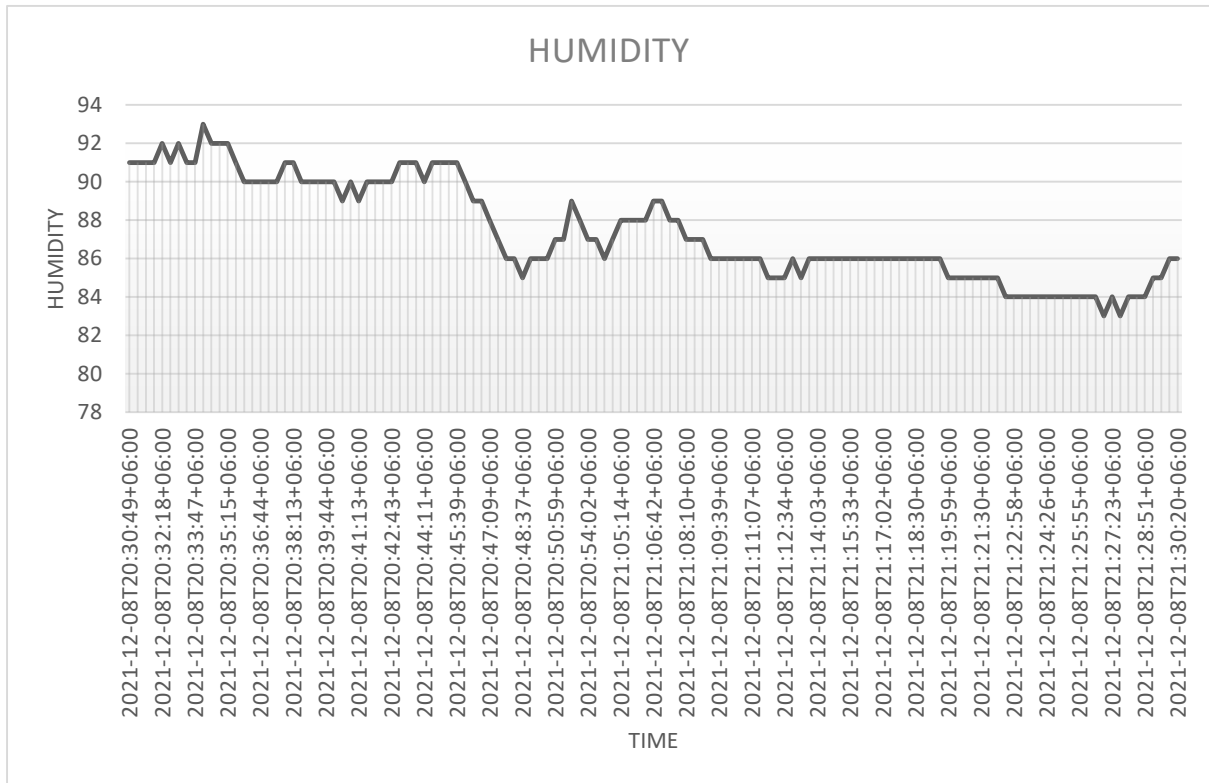

Figure 4.20:- Plot of Humidity Sensor; Data taken for Critical Conditions.

From Fig:-4.20 we can see that the Humidity sensor is giving a sensor value of 87 at 9.02 pm . So from the graph it is clear that the humidity sensor meets all the conditions for critical scenarios. The graph moves with respect to time. That means the humidity value of the temperature and humidity sensor is 87 percent.

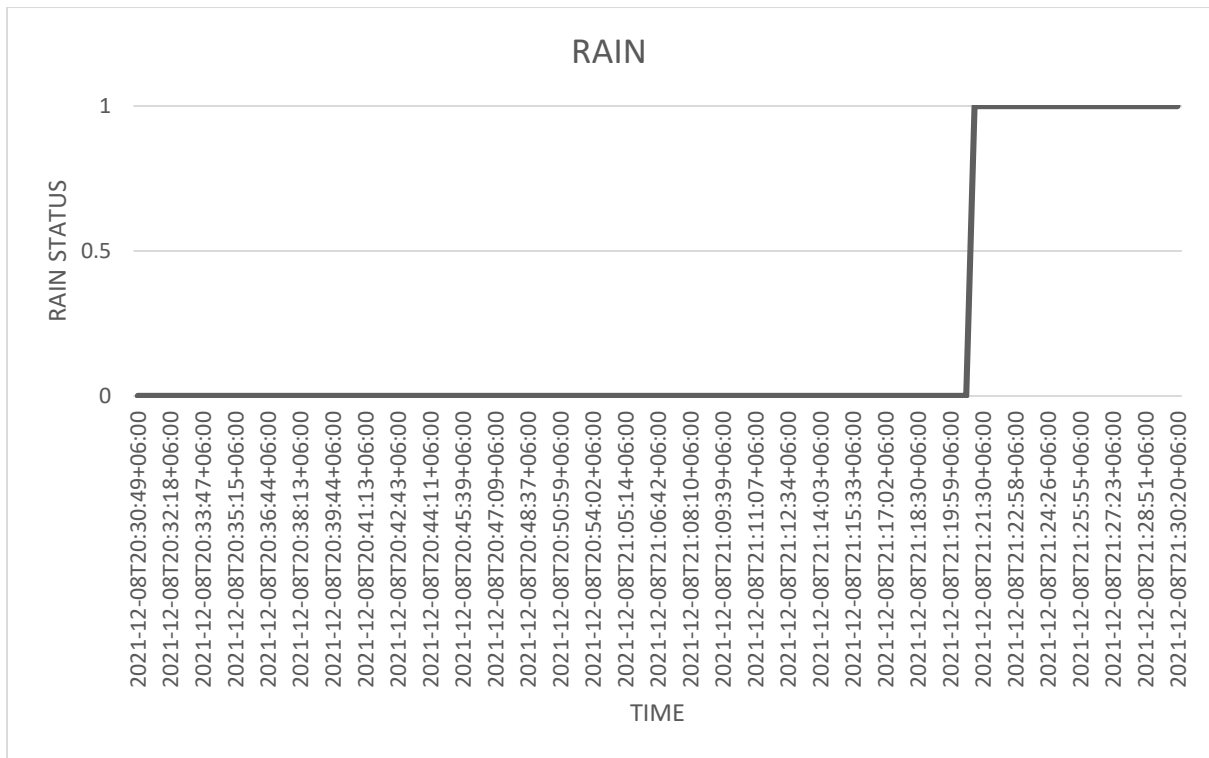
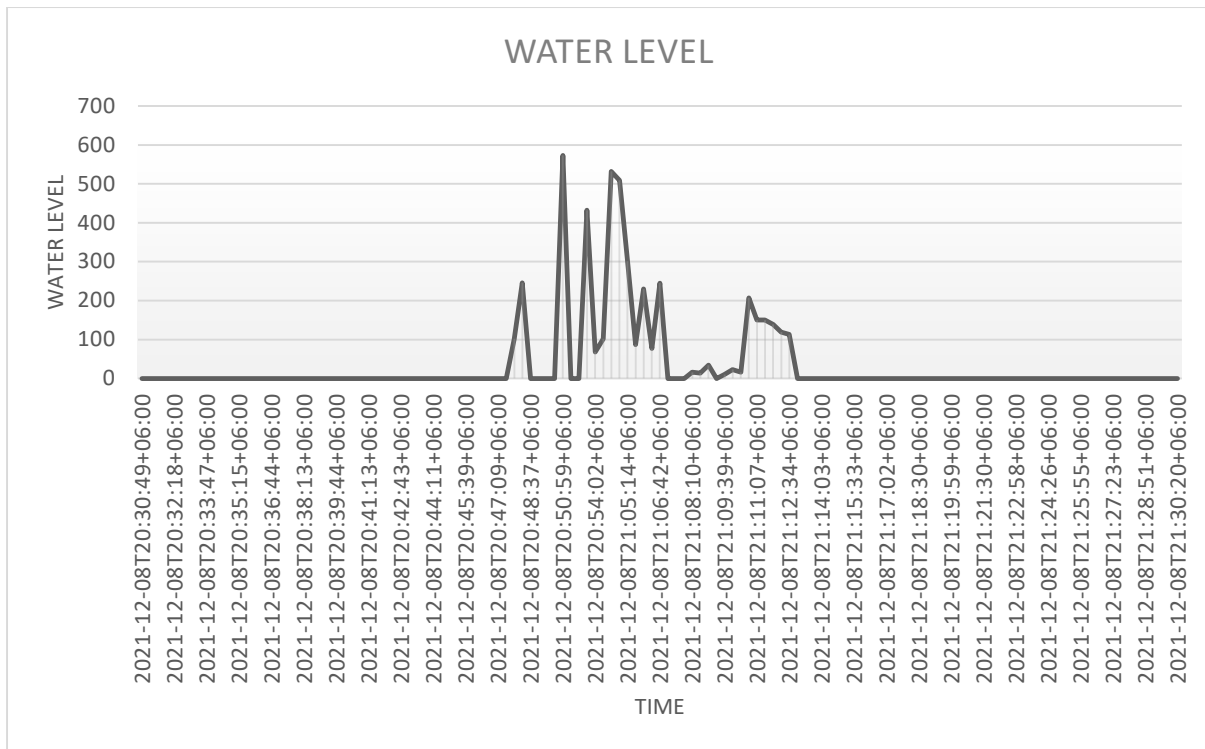

Figure 4.21:- Plot of Rain Sensor; Data taken for Critical Conditions.

From the Fig:-4.21 it is observed that the rain sensor gives 0 as output at 9.02 pm , so that means it is raining extremely. This sensor value meets the condition for critical scenarios. This data has been collected from the situation created artificially. Here water is given to rain sensor to sense rain.



Graph 4.22:- Plot of Water level Sensor; Data taken for Critical Conditions.

From Fig:-4:22 we can see that at 9:02 pm the water level sensor value from the graph is greater than 500 which means the water level is extremely high and the critical scenario is activated . In this scenario the embankment is at great risk and the probability of flood occurrence is extremely high. This water sensor value is taken by planting water sensor in an embankment prototype artificially.

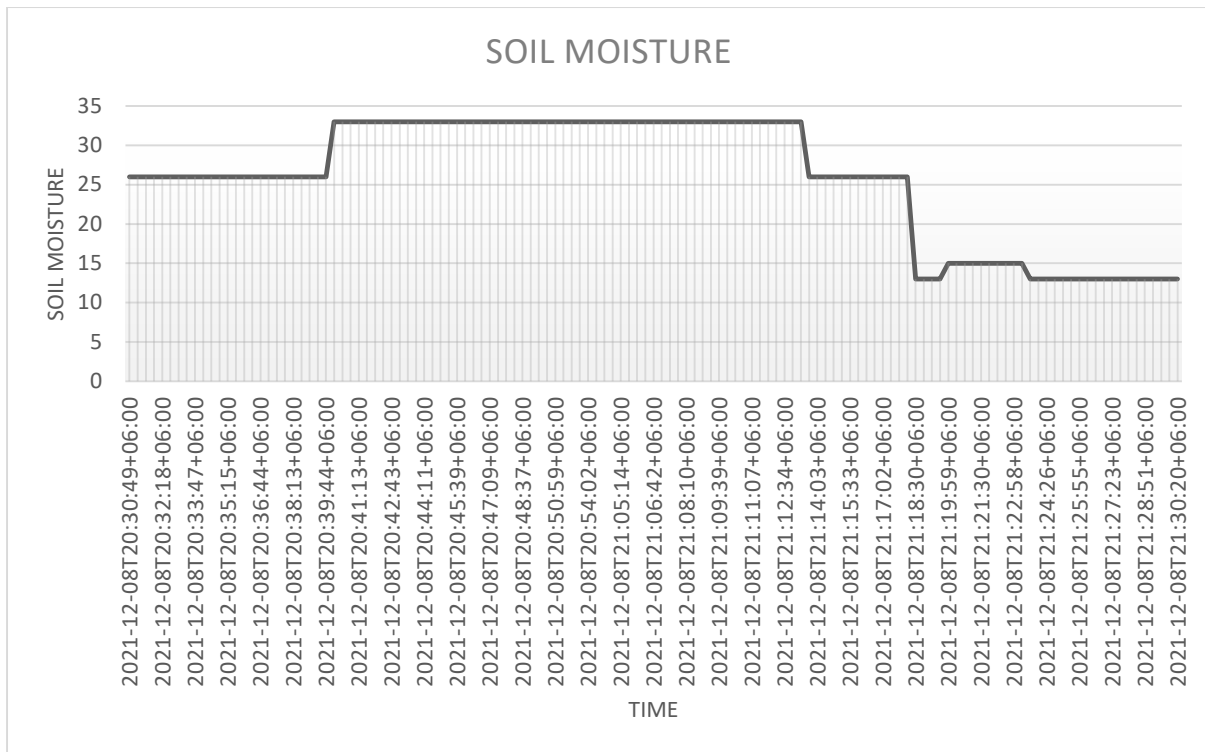

Graph 4.23:- Plot of Soil moisture Sensor; Data taken for Critical Conditions.

The above Fig:-4.23 gives the value of the soil moisture sensor greater than 30 that means the soil moisture is extremely soggy at 9:02 pm .In this condition the sustainability of the embankment is low and the embankment may collapse anytime which may result in a flood occurrence . Soil moisture is placed in the soil of the embankment to take all the data artificially.

In this scenario when the water level is extremely high, raining at a very high rate and the soil moisture is extremely soggy which indicates the embankment’s sustainability is at high risk and the probability of flood occurrence is maximum. Then the ESP32 of the monitoring system will activate the warning system. The warning system will initialize a response to the IFTTT cloud server in order to trigger a sms to the cell phones of the inhabitants at high risk zones. This system will respond immediately and initiates a warning message to minimize the damage due to flood.

1 12-8 21:02

Humidity- 87.00 Temperature-
26.50 it's raining , Water
level-high. Soil moisture-Soggy.
Move to the save place. Occured
at: [December 8, 2021](#) at [09:02PM](#)

Humidity- 87.00 Temperature-
26.50 it's raining , Water
level-high. Soil moisture-Soggy.
Move to the save place. Occured
at: [December 8, 2021](#) at [09:02PM](#)

Figure 4.24:-Message from the Warning System.

From the above Fig:-4.24, it is observed that at normal scenarios the embankment's sustainability is out of risk. But in case of moderate scenarios the embankment will be able to absorb the strong river water flow and can act as a protective body against high water level. In case of critical scenarios these graphs give a clear idea of extremely high water level and soil moisture level. So in this case the embankment's sustainability will be at great risk and may collapse after some period of time.

4.3 Simulation Result:-

The simulation result of the system gives the reading of the temperature, rain, water level and soil moisture sensor. In this simulation the data. From the sensor goes to the arduino. Arduino initiates a message system through the gsm module by giving all the sensor data through message. From Fig:-4.25 it is observed that gsm module sends message for each sensor value.

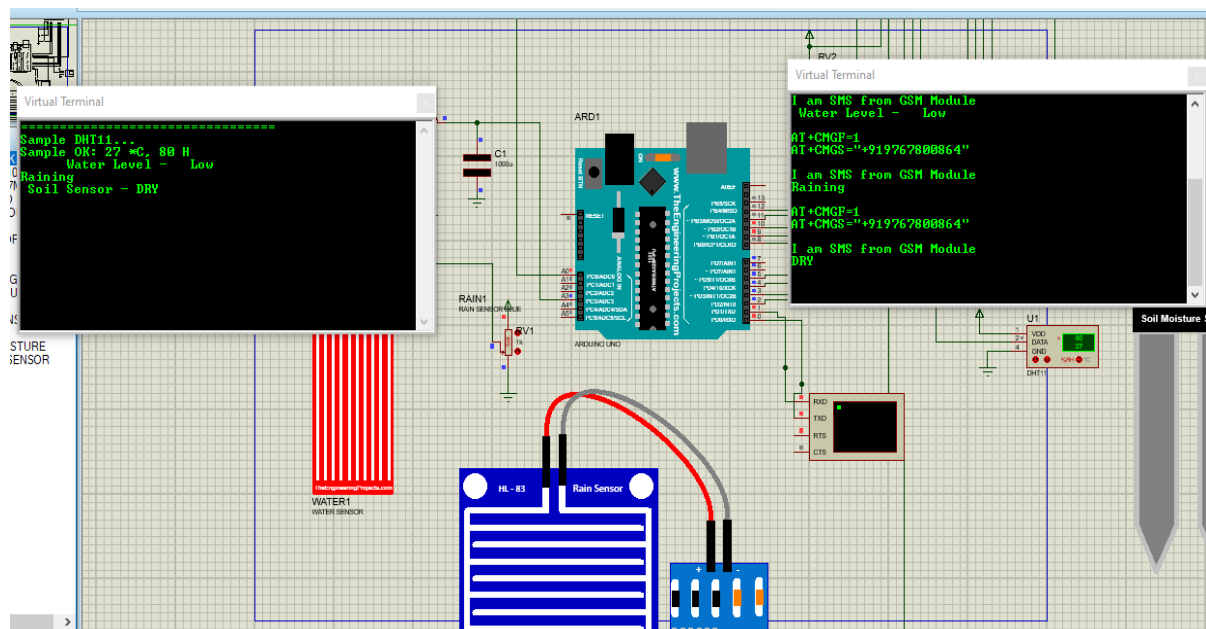

Figure 4.25: - Simulation result of the system

Chapter-5

Conclusion & Future Work

With the advancement of the modern technology and Internet system every aspect of today's world is now developing by technological touch. Even the unpredictable natural calamities and disasters now can be monitored by modern technology accurately before it may occur. Floods are one of the most dangerous and fatal disasters which affect people's property and life. So, The main objective of this research work is to develop a system which can monitor and warn people about floods in the flood prone area of a country before a flood occurs. This system consist of an embankment along with different sensors namely rain sensor, water sensor, soil moisture sensor, temperature sensor have been used to give real life data respectively with continuous process which eventually transferred to the Esp 32(a nodemcu).The nodemcu then after processing the data referred it to the Thingspeak (a user interface system) which will generate graphs about the real life data which eventually can monitor about flood occurrence. After monitoring the real life data and graphical analysis now IFTTT (a cloud server) will give a warning message to the near disaster management office and to the general people to take the safety measures. This system will also predict about the sustainability of the embankment which is one of the measure stick about flood coming. This research is an IOT based modern technological system which works accurately for the solution of the problem and this research work can be the pathfinder of the future advancement.

References:

1. *OECD Climate Change*. OECD. (n.d.). Retrieved December 13, 2021, from <https://www.oecd.org/climate-change/>.
2. *Map of flood-affected areas in bangladesh / download ...* (n.d.). Retrieved December 14, 2021, from https://researchgate.net/figure/Map-of-flood-affected-areas-in-Bangladesh_fig1_326263766.
3. Wikimedia Foundation. (2021, December 6). *Floods in Bangladesh*. Wikipedia. Retrieved December 13, 2021, from https://en.wikipedia.org/wiki/Floods_in_Bangladesh.
4. Wikimedia Foundation. (2021, November 22). *Geography of bangladesh*. Wikipedia. Retrieved December 13, 2021, from https://en.wikipedia.org/wiki/Geography_of_Bangladesh.
5. MOHAMMED KHALAF,HAYA ALASKAR ,ABIR JAAFAR HUSSAIN,THAR BAKER,ZAKARIA MAAMAR,RAJKUMAR BUYYA,PANOS LIATSI ,WASIQ KHAN,HISSAM TAWFI AND DHIYA AL-JUMEILY “ IOT enabled flood severity prediction via ensemble machine learning models” vol 1 pp 70375-70376 april 2021 .
6. M.Anbarasan BalaAnandMuthu .B.Sivaparthipan RevathiSundarasekar SeifedineKadry SujathaKrishnamoorthy Dinesh JacksonSamuel A Antony Diesel “Detection of flood disaster system based on IoT, big data and convolutional deep neural network”Vol 150 PP 150-152 15 January 2020
7. Jirapon Sunkpho and, Chaiwat Ootamakorn “Real-time flood monitoring and warning system” pp 1-2 29 march 2011
8. Nandhini N,Lavanya N, and Kowshika V “Flood Monitoring and Alerting System Using Arduino In IoT” pp 1-4 may 2021 International Conference on Smart Data Intelligence (ICSMDI 2021)
9. Garima Singh, Nishita Bisht, Pravesh Bisht, Prajjwal Singh “Iot Based Flood Monitoring and Alerting System with Weather Forecasting” Vol-9 pp 559-561 International Journal of Innovative Technology and Exploring Engineering (IJITEE) ISSN: 2278-3075, , April 2020

10. K. Sundar Srinivas ,Sajid Baig,T.Navya sri, Y Praneeth,V Nagaakakshmi “FLOOD MONITORING SYSTEM USING THINGSPEAK WEB SERVER AND IFTTT” vol 05 pp 1-3 may 2020
11. Swapnil Bande and Virendra V.Shete “ Smart flood disaster prediction system using IoT & neural networks” 2017 International Conference On Smart Technologies For Smart Nation (SmartTechCon)
12. Wenjia Tang, Jiamin Hong, Xinzhou Huang and Jian Huang “Key issues on seepage analysis in mountain river embankment” pp 2 ,5-7, 2018 “International Conference on Civil and Hydraulic Engineering (IConCHE 2018)” .
13. Admin. (2020, November 19). *Rain sensor module: How it's works " electroduino*. ElectroDuino. Retrieved December 9, 2021, from <https://www.electroduino.com/rain-sensor-module-how-its-works/>.
14. Admin. (n.d.). *Happenings: Water level sensor arduino specifications : How to use a water level sensor module with Arduino Scidle : We did not find results for:* diari. Retrieved December 9, 2021, from <https://diari-happenings.blogspot.com/2021/08/water-level-sensor-arduino.html>.
15. Wikimedia Foundation. (2021, August 25). *Soil moisture*. Wikipedia. Retrieved December 14, 2021, from https://en.wikipedia.org/wiki/Soil_moisture.
16. *Dht11–temperature and humidity sensor*. Components101. (n.d.). Retrieved December 9, 2021, from <https://components101.com/sensors/dht11-temperature-sensor>.
17. *ESP-01 WIFI module - microchip*. (2020). Retrieved December 9, 2021, from <https://www.microchip.ua/wireless/esp01.pdf>.
18. *Hardware specifications of the environmental sensors ...* (2020, December). Retrieved December 9, 2021, from https://researchgate.net/figure/Hardware-Specifications-of-the-Environmental-Sensors_tbl2_51872997.
19. *Learn more about ThingSpeak*. Learn More - ThingSpeak IoT. (n.d.). Retrieved December 9, 2021, from https://thingspeak.com/pages/learn_more.
20. Macfos. (2021, February 9). *Arduino Pin Configuration: A detailed guide (2021)*. Robu.in | Indian Online Store | RC Hobby | Robotics. Retrieved December 9, 2021, from <https://robu.in/arduino-pin-configuration/>.

21. Wikimedia Foundation. (2021, December 8). *Arduino*. Wikipedia. Retrieved December 14, 2021, from <https://en.wikipedia.org/wiki/Arduino>.
22. *Online educational platform*. Gazi Online School. (n.d.). Retrieved December 9, 2021, from <https://www.gazionlineschool.com/flood-in-bangladesh-essaycomposition%E2%80%94>
23. Wikimedia Foundation. (2021, November 30). *ESP32*. Wikipedia. Retrieved December 9, 2021, from <https://en.wikipedia.org/wiki/ESP32>.
24. Tobo, Santos, S., Amos, D., Carlos, Elliott, D., G, K., Calum, P., mtz8302, Moataz, Waldemar, Parsons, C., Fensie, R., Ericsson, J., Dali, Pablo, J., Nguyen, P., Bestware, Lopes, J., mohanraj52, ... Silva, I. D. (2021, August 17). *ESP32 pinout reference: Which GPIO pins should you use?* Random Nerd Tutorials. Retrieved December 14, 2021, from <https://randomnerdtutorials.com/esp32-pinout-reference-gpios/>.