

**ESTABLISHMENT OF ‘BRAC ONNESHA’ NANO SATELLITE GROUND STATION  
AND COMPARITIVE ANALYSIS OF DIFFERENT TYPES OF ANTENNA AS A  
PORTABLE LOW EARTH ORBIT SATELLITE GROUND STATION RECEIVING  
ANTENNA**



Inspiring Excellence

A Thesis submitted to the  
Department of Electrical & Electronics Engineering  
Of  
BRAC University  
By  
Md. Arafat Haque- 12321008  
Jamil Arifin-12221102

Supervised By

Dr. Md Khalilur Rhaman

Associate Professor

Department of Computer Science and Engineering

BRAC University

Co-Supervised By

Dr. Md. Hasanuzzaman Sagor

Assistant Professor

Department of Electrical & Electronics Engineering

BRAC University

In partial fulfilment of the requirements for the degree of  
Bachelor of Science in Electrical and Electronic Engineering

August 2017

BRAC University, Dhaka

### **Declaration**

We hereby declare that research work titled “ESTABLISHMENT OF ‘BRAC ONNESH’ NANO SATELLITE GROUND STATION AND COMPARITIVE ANALYSIS OF DIFFERENT TYPES OF ANTENNA AS A PORTABLE LOW EARTH ORBIT SATELLITE GROUND STATION RECEIVING ANTENNA” is our own work. This paper has not been presented elsewhere for assessment. Where materials were used from other sources it has been properly acknowledged/Referred.

---

Signature of the Supervisor

Dr. Md Khalilur Rhaman

Signature of the Authors

---

Md. Arafat Haque

---

Jamil Arifin

## Table of Contents

Acknowledgement.....	04
Abstract.....	05
<b>1 Introduction.....</b>	<b>06</b>
1.1 Literature Review.....	06
1.2 The BRAC Onnesha Project.....	07
<b>2 BRAC Onnesha Ground Station.....</b>	<b>10</b>
2.1 Ground Station Hardware Equipment.....	10
2.1.1 VHF Antenna.....	11
2.1.2 M2 436-CP42UG Antenna.....	12
2.1.3 HD FG 11, Crossboom.....	13
2.1.4 Yaesu G-5500.....	14
2.1.5 GS-232B.....	15
2.1.6 KP-2/440 Pre Amplifier.....	15
2.1.7 Transceiver IC-9100.....	16
2.1.8 Ground Station Software.....	17
2.2 Assembling Ground Station System.....	18
2.2.1 UHF/VHF Antenna And Antenna Control Unit.....	18
2.2.2 Dual Band Radio Transceiver for Transmitting and Receiving.....	19
2.3 Ground Station Operation.....	20
2.3.1 Turn On and Turn Off The Ground Station Hardware.....	20
2.3.2 Operation Instruction.....	22
<b>3 Antenna Theory.....</b>	<b>30</b>
3.1 Basic Parameters of Antenna.....	30
3.1.1 Frequency.....	30
3.1.2 Radiation Pattern.....	30
3.1.3 Directivity.....	31
3.1.4 Antenna Gain.....	31
3.1.5 Bandwidth.....	31
3.1.6 Antenna Temperature.....	31
3.1.7 Antenna Impedance.....	31
3.1.8 Reflection Co-efficient.....	32
3.1.9 VSWR.....	32
3.1.10 Loss Due To Electrical Wave Propagation Delay.....	33
3.2 Background Information.....	33
3.2.1 Yagi-Uda Antenna.....	33
3.2.2 GFH Antenna.....	34
3.2.3 Lindenblad Antenna.....	35
3.2.4 V- Dipole Antenna.....	36

<b>4</b>	<b>Experimentation.....</b>	<b>38</b>
4.1	Portable Ground Station Setup.....	38
4.1.1	Hardware.....	38
4.1.2	Software.....	38
4.2	Design and Calculation .....	40
4.2.1	Yagi-Uda Antenna.....	40
4.2.2	QFH Antenna.....	43
4.2.3	Lindenblad Antenna.....	47
4.2.4	V- Dipole Antenna.....	49
4.3	Simulation of Radiation Pattern.....	50
4.3.1	Yagi-Uda Antenna Radiation Pattern.....	50
4.3.2	QFH Antenna Radiation Pattern.....	52
4.3.3	Lindenblad Antenna Radiation Pattern.....	52
4.3.4	V-Dipole Antenna Radiation Pattern.....	53
5	Result and Analysis.....	54
5.1	Radiation Pattern Simulation Comparison.....	54
5.2	Experiment Data Comparison .....	54
6	Summary.....	68
6.1	Conclusion.....	68
6.2	Future Work.....	68
7	References.....	70
8	Appendix.....	72
8.1	Codes.....	72
8.2	Additional Images.....	73

## **Acknowledgement**

We are very thankful to Dr. Md. Khalilur Rhaman and Dr. Md. Hasanuzzaman Sagor for giving us the opportunity to conduct this thesis program, without their endless support this thesis would not have been possible.

We are grateful to BRAC University for providing us with all the resources we needed in order to conduct our work. We were very fortunate to receive their endless support.

We would also like to thank Abdullah Hil Kafi, Maisun Ibn Monowar and Raihana Shams Islam Antara for giving us their support and guidance. Also we would like to thank Mozammel Haque for his support. Never the less, we would like to thank Syed Sumsul Alam Tuhin & Anup Kumar for sharing their knowledge with us.

Last but not the least, other team members of the BRAC Onnesha Nano Satellite ground station who has always been a great support throughout the whole project.

## ABSTRACT

BRAC ONNESHHA is the first Nano-Satellite of Bangladesh which opened path for students to start research in space engineering. BRAC Onnesha Ground station is the first Nano-Satellite Ground station of Bangladesh assembled and interfaced by BRAC University students. The BRAC ONNESHHA Ground station setup has been studied in this Thesis. BRAC ONNESHHA is a polar orbiting CubeSat. Polar orbiting satellite operations often require portability of ground station. Mostly the satellites in low earth orbit are Cube Satellites. Cube Satellites are small scale satellites whose electronics is consisted of extremely low power consuming components. For this reason the power of transmitting signal from Cube Satellites are very low powered making it very challenging for ground stations to receive the signals, especially in High Radio Frequency dense areas. As Satellites and their Ground Station is not cheap, for developing countries like Bangladesh it is quite difficult for researchers to avail a Portable Ground Station. It is very crucial for researchers to avail portability of satellite ground station as it is quite often required to receive signals from less Radio Frequency dense areas. For this purpose a low cost feasible ground station with a comparison of several antennas for VHF and UHF frequencies has been chosen to be analyzed in this report. The directional and omnidirectional antennas used for this portable ground station system can be easily constructed with raw materials available locally in Bangladesh. The system uses a KENWOOD Tri Band Handheld Radio as the system's RF receiver and transmitter.

# **1 Introduction**

Space is the final frontier of science where humans send their highest level of technology to be benefitted for later years. Space engineering and science has always been a subject for the first world countries mostly because of the expense of a space research. Countries like Bangladesh for this reason lacks proper space agencies and space based scientific research. People are more in need of money for poverty, education and medicine. Until the past decade as cheaper satellite technologies are emerging like Nano satellites and private space agencies like SPACEX has started to launch commercially in to space, Bangladesh is already in space for the first time in history as BRAC ONNESHHA has been launched into space in 7<sup>th</sup> of July 2017. Later in the year 2017, Bangladesh shall launch its first commercial geostationary satellite also known as Bangabandhu-1. As a developing country entering in space research and space based commercial business, Bangladesh will have to evaluate different cheaper radio frequency receiving systems, devices and different portable antennas to progress this science in our own renewable and low cost process. This will enable us to acquire weather updates, learning to communicate and monitor the health of a satellite and to communicate in the amateur radio spectrum. As space research is a necessity in the twenty first century to develop new radio communication system to enrich the space engineering of Bangladesh. From these small steps one day Bangladesh shall be able to send their own made satellite into space.

## **1.1 Literature Review**

A group of students from BRAC University started research in Space Engineering by starting a model for possible Nano-satellite structure in 2015 which could endure the harsh environment in space. As Bangladesh is going to launch its very first commercial communications satellite Bangabandhu-1 later this year and BRAC University has already launched the first Nano-satellite for Bangladesh, BRAC Onnesha is now a crucial time to expand research the domain of space engineering. Moreover as Bangladesh is a disaster prone area in the global scenario and most of the rural people are engaged in earning money through agriculture, it is extremely important for the people to be updated to the current weather. Again for detailed climate change reports a

nation's related agencies should be updated with such needs. But sadly Bangladesh has no weather satellite and the data the agencies in Bangladesh receive are from weather satellites of other countries for which we have to pay.

In order to improve our consciousness regarding weather updates from satellite, portable ground station has been proposed in rural coastal areas of Bangladesh. Here with the help of local Amateur Radio Operators downlinking free data from commercial weather satellites to provide an increase in the insight of the formation of cyclones and hurricanes at sea is proposed to be observed by a portable satellite ground station system. Through this we can also observe sea surface temperature and can tell the amount of sea and land ratio in coastal areas.

A satellite ground station of such requirements is usually proposed to have omnidirectional antenna to simplify the system and to reduce error in tracking. Directional antenna requires the system to point the antenna in the direction of satellite as the satellite passes the ground station. Sadly the rotator is not very portable as most rotators are heavy and not very easy to setup anywhere and takes a lot of energy where else the omnidirectional antenna requires no rotator and consumes less energy of the ground station.

## **1.2 The BRAC Onnesha Project**

CubeSat is a very recent approach to space research enabling small scale low cost satellites in low earth orbit. BRAC Onnesha is a CubeSat of 1U (10cm\*10cm\*10cm) which is the 1st Nano Satellite of Bangladesh to be in polar orbit from 7 July, 2017. Through this, for the first time Bangladesh has stepped in the space. The satellite will be using amateur radio frequency bands UHF and VHF for communication on earth for downlink and uplink respectively.

The journey of BRAC Onnesha project began with the Signing Ceremony of BRAC Onnesha. A MOU (Memorandum of Understanding) was made between BRAC University, Bangladesh and Kyushu Institute of Technology or in short Kyutech, Japan. The BRAC Onnesha satellite is a part of JOINT GLOBAL MULTI NATION BIRDS project, (JGMNB). The idea of BIRDS Project is to build a Nano satellite for non-space faring countries by the representatives of those countries in Japan. Three BRAC University students Abdulla Hil Kafi, Raihana Shams Antara and Maisun Ibn Monowar, who were already studying in the postgraduate program in Kyutech



represented Bangladesh with four other countries namely Japan, Nigeria, Ghana and Mongolia. Each country will have their own satellite of 1U size in the satellite constellation. These students from five countries will design, implement, assemble, test and finally deploy to Low earth orbit via International Space Station's robotic arm starting from 2015 and finishing everything by mid-2017. BRAC University has financed the whole project for BRAC Onnesha and Kyutech shared the technology required to develop this satellite and all the testing facility. BRAC Onnesha is a milestone to the advancement of Science and Technology in Bangladesh. The objectives of this satellite are completing the following missions:

- Take high quality aerial photograph of land to analyze vegetation, urbanization, flood, sea are surveillance, meteorology data etc.
- Observe space environment.
- Monitor satellite location.
- Demonstrate Ground Station Network for Nano-satellite constellation.
- Attain multi-point simultaneous space environment measurement.
- Broadcast audio signal and attain communication through HAM radio during emergency and catastrophe. Also play national anthem on special national days.

The satellite project requires each country to have a dedicated ground station for their own satellite. So for this reason a team of students were assigned at BRAC University to construct the BRAC Onnesha Ground Station at BRAC University campus. The Ground stations will be of same configuration in all countries. The Project of BRAC Onnesha is headed in Bangladesh by Dr. Md. Khalilur Rhaman as Principal Investigator and Dr. Md. Hasanuzzaman Sagor as Assistant Investigator.



## LOW EARTH ORBIT

Low Earth Orbit (LEO) is a satellite orbit around the earth ranging from 500km to 1200km.

These orbiting satellites in this orbit are below the Van Allen radiation belt.

## **2 BRAC ONNESHHA GROUND STATION**

BRAC ONNESHHA ground station is a part of BIRDS satellite program. The whole system was assembled by the students of BRAC University namely Mozammel Haque, Bijoy Talukdar, Jamil Arifin, Sananda Jagati Chayan, Arafat Haque, Aynul Huda and Md Sakiluzzaman. As it is a part of multinational project the configuration of all the ground stations in BIRDS including our BRAC ONNESHHA Ground Station is also identical to the other six ground stations all over the world. BRAC Onnesha Ground Station is designed to transmit and receive signals to and from satellites that use Amateur Band frequencies for Uplink and Downlink, usually CubeSat. The Ground Station is the first of its kind in the country and it is fully operational now. It has successfully received data from HORYU4, AOBA VELOX-3, AO-7 and many other cube satellites and also from NOAA-15, NOAA-18 and NOAA-19 weather satellites several times.

### **2.1 Ground Station Hardware Equipment**

The ground station is consisted of several sophisticated equipment. The antenna transmits and receive radio signals by detecting the electromagnetic waves. It has been aligned to face perfectly with the Magnetic North pole of Earth and mounted on top of a 30 feet tower which was placed on a fifteen storied building. The signal comes through the antenna to the pre-amplifier and then to the dual band radio transceiver. The Transceiver has different filters and the received signal is filtered to the desired level of clarity as it is decoded at the same time with the help of respective signals decoder, in case of HORYU4 we used CWGet and for NOAA satellites we used WxtoImg. The Rotator and its control unit is used to determine the azimuth and elevation of the antenna to track the polar orbiting Satellites as they pass over the Ground Station. The Transceiver and the Rotator control unit is connected to a desktop computer from where the entire system is controlled through HAM Radio Deluxe. In our case we will be using transceiver is ICOM 9100 and the antenna controller is the Yeasu G-5500, Rotator Controller Computer Interface Yeasu 232-B.

Features And Specifications Of the Equipment Are Given Below.

### 2.1.1 VHF Antenna:

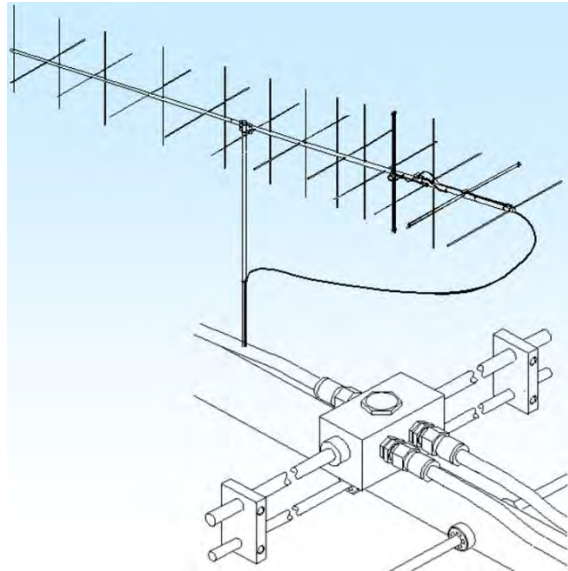

Figure: VHF Antenna

This specific model of antenna is designed to operate in VHF band (30 to 300 MHz). It uses folded dipole as feed. Its circular polarization makes it suitable for satellite communication. This antenna will be used for uplink command to the satellite. It has a directional radiation pattern and very high gain.

#### Features:

1. Gain 14.39 dBic
2. Beam width 38°
3. Folded Dipole Feed
4. Cross polarization
5. Average side and back lobes power reduced by approximate 10dB over any previous design
6. Finest Circular polarized antenna

### 2.1.2 M2 436-CP42UG Antenna:

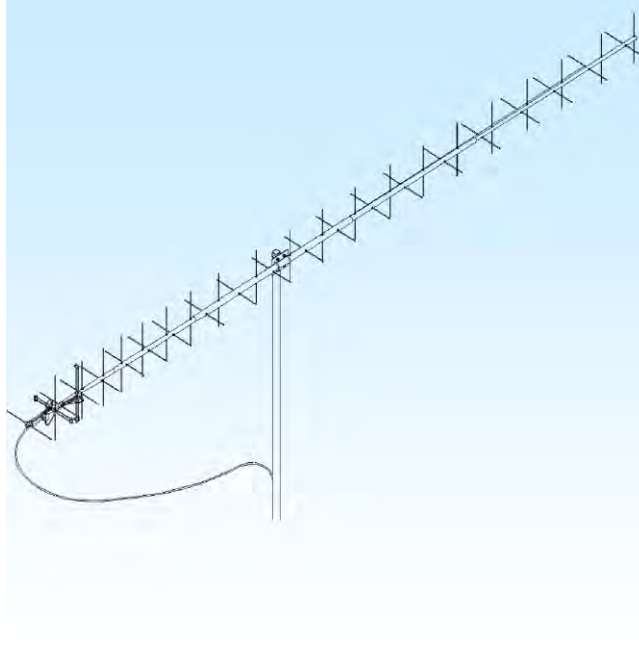

**Figure: M2 436-CP42UG Antenna**

M2 436-CP42UG model antenna is used for downlink data from satellite. The frequency range of this antenna is 420-440 MHz which is in UHF band. The CP42UG is also excellent for ATV, repeater operation. As satellites transmit in very low power, 18.9 dBic gain of CP42UG makes it easier to receive data.

#### **Features:**

1. 18.9 dBic Gain
2. 21° circular beam width
3. Folded Dipole Feed
4. Cross polarization
5. Excellent for ATV, repeater operation
6. Driven element and 'T' blocks are CNC machined.

### 2.1.3 HD FG 11, Crossboom:

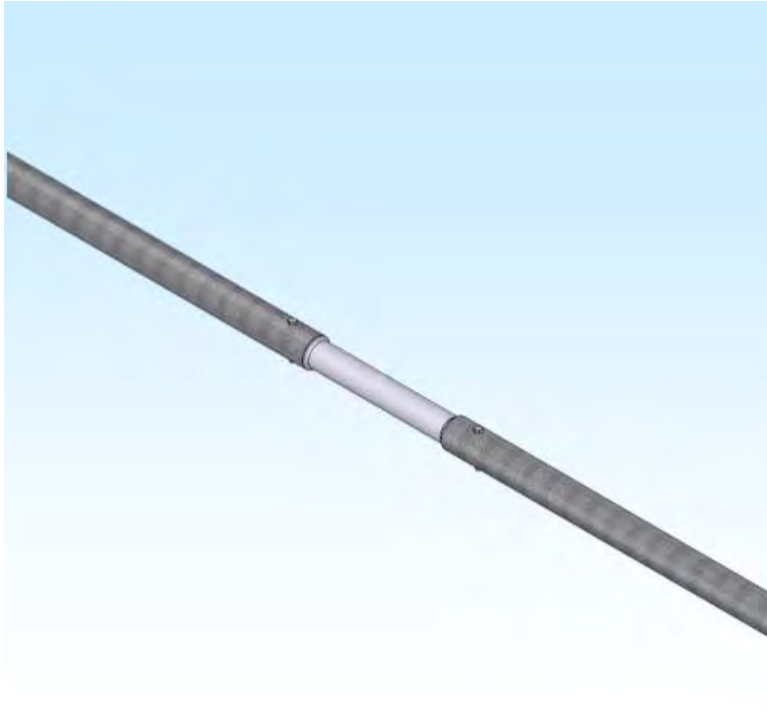

**Figure: Fiberglass Crossboom**

The HDFG11 fiberglass cross boom has been developed to work with Yeasu G-5500 and G-550. It consists of a solid aluminum center rod and 2.0×.250 wall Fiber Glass tube on each side of the center rod

#### **Features:**

1. Allows solid clamp
2. Years of slip free service
3. Thick wall fiber glass tube

### 2.1.4 Yaesu G-5500:



**Figure: Yaesu G-5500**

Yaesu G-5500 is an Azimuth-Elevation combination rotator. Thus it is ideal for satellite communication antennas. The Azimuth rotator turning range is  $450^\circ$ , while the Elevation Rotator has a rotation range of  $180^\circ$ . The control unit is a desktop unit with dual meters and direction controls for azimuth, in compass direction and degrees; and elevation from  $0^\circ$  to  $180^\circ$ .

#### **Features:**

1. Ideal for Amateur application.
2. Interface jack for computer control.
3. Weather proof rotator unit.
4. Dual meters and direction control for azimuth and elevator.

### 2.1.5 GS-232B:



Figure: Yaesu GS-232B

The GS-232B is the computer control interface for the antenna rotators. It provides digital control of the antenna rotators from the serial port of an external personal computer. The GS-232B contains a microprocessor with a 10 bit analog to digital (A-D) converter and EEPROM.

#### Features:

1. PIC 18C452 Microprocessor
2. 24LC256 EEPROM
3. Serial communication port
4. Overflow Control (CTS port)

### 2.1.6 KP-2/440 Pre amplifier:





High gain ultra-low noise GaAsFET preamps for receiving weak signals. Select-able gain prevents receiver intermode. 15-22 dB gain. Auto RF switching to 160W. In-shack and Mast-Mount both type of model are available. It operating voltage is 12-15V DC.

**Features:**

1. Automatic RF Switching
2. GaAsFET boosts weak receive signals
3. Mast Mounted design to reduce loss
4. In-Line design for easy operation
5. High or Low switchable gain setting
6. Gain: from 15 dB to greater than 25 dB
7. Noise: less than 1 dB
8. Power Handling: 100 Watts
9. Voltage: 12-15 VDC

**2.1.7 Transceiver IC-9100:**



Figure: IC-9100 Transceiver

Icom-9100 is a desktop amateur HF/VHF/UHF Transceiver. It can simultaneously receive on two different bands and works as if there are two independent receivers. It has four CW memories, voice squelch control, band edge beep, built-in voice synthesizer. The multi-function meter shows signal strength, output power, SWR, ALC and compression level.

**Features:**

1. Built-in HP/50MHz ATU (Tuner)

2. IF-DSP (32-bit operation and 24-bit ADC)
3. 24 bit A/D converter
4. Rear-panel USB port
5. RIT/XIT
6. Digital Noise Reduction
7. Manual and Automatic Notch
8. Digital Twin PBT
9. Dual Display
10. 100 Watt Output (75W on 440)

### **2.1.8 Ground Station Software:**

1. Ham Radio Delux
2. Orbitron
3. WXtoImg
4. CWget

## 2.2 Assembling Ground Station System

The ground station can be divided into two main systems:

- UHF/VHF Antenna and Antenna Control Unit
- Dual band radio transceiver for transmitting and receiving

### 2.2.1 UHF/VHF Antenna and Antenna Control Unit:

#### Pre Amplifier System:

As the ground station is designed such that it will receive beacon from BRAC ONNESHHA at UHF band. So, Pre-amplifier is connected after 25 feet Coaxial cable from the UHF antenna, then 100 feet Coaxial cable from Pre-amplifier to the Pre-amplifier control box, then a 5 feet coaxial cable connects the Pre-amplifier to the Transceiver ICOM 9100 by N type connector. All Coaxial cables are RG8 cables.

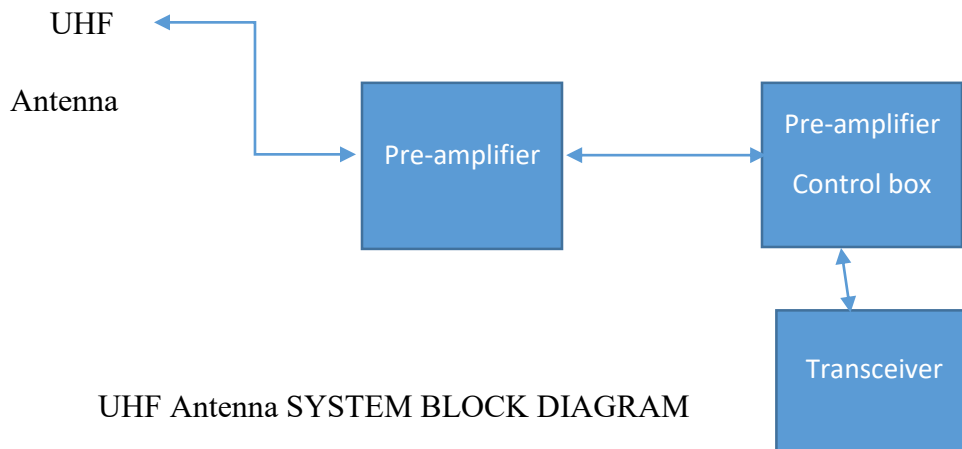

UHF Antenna SYSTEM BLOCK DIAGRAM

The VHF antenna is connected directly to the radio with a PL-259 connector. As satellites which the ground station tracks are all polar orbiting satellites thus require the antenna system to be able to move according to the position of the satellite. For this purpose the ground station is equipped with a rotator Yaesu G-5500 and its computer interface Yaesu GS-232B to control it from computer.

The ground station uses two antenna for its communication. For communication we have used VHF Antenna and M2 436-CP42UG. Both of these antenna are directional cross Yagi-Uda antenna with circular polarization.

### 2.2.2 Dual band radio transceiver for transmitting and receiving

The dual band radio transceiver that has been selected for BRAC Onnesha is ICOM 9100.

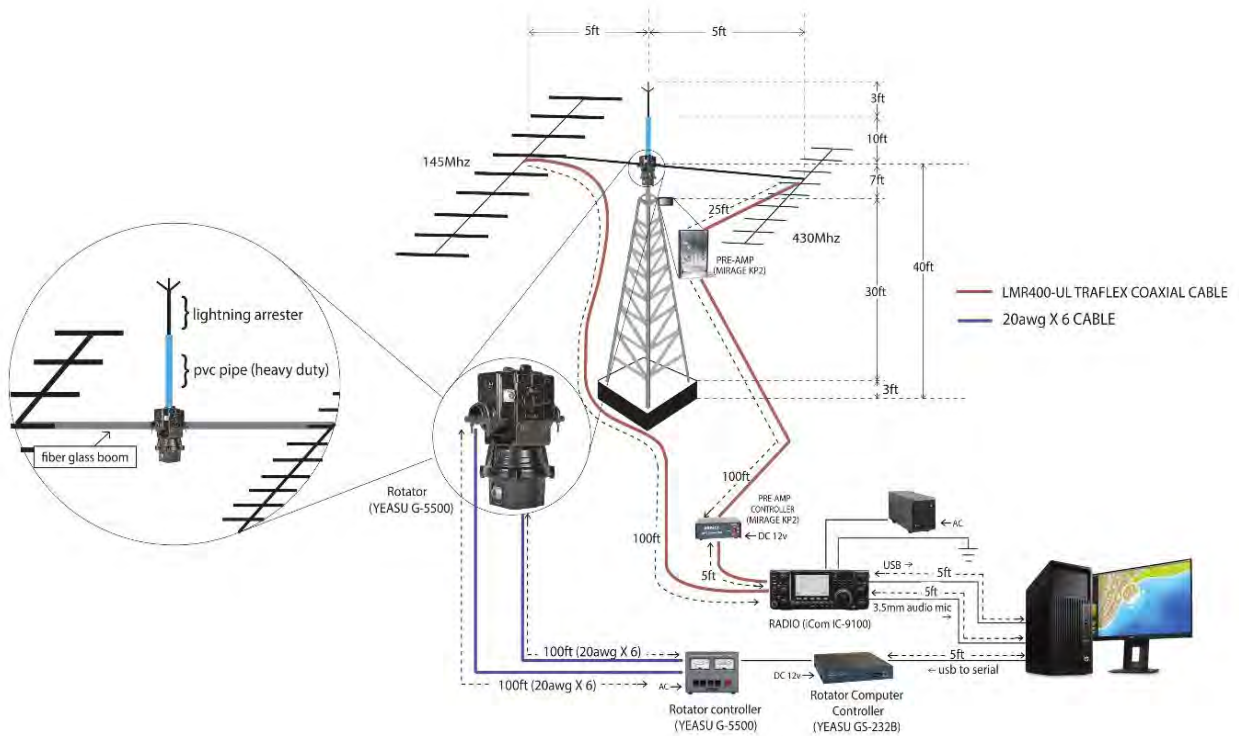

fig. BRAC ONNENSHA GROUND STATION SETUP

## 2.3 Ground Station Operation:

The elements of this operation are as follows:

- How to turn on and shutdown the equipment in ground station.
- The guideline of tracking software and Ground Station operation programming.
- How to decoded and break down CW signal.
- How to send uplink order and receive information from satellite.

### 2.3.1 Turn on and turn off the Ground Station hardware

#### Turn on

DC power supply ON >> Radio ON >> Rotor Controller ON >> Rotor Interface Box ON

#### Turn off

Rotor Interface Box OFF >> Rotor Controller OFF>> Radio ON >> DC Power Supply

#### Devices Switch Detail

DC Power Supply



## Radio Transceiver



## Rotor Controller



## Rotor Interface Box



### 2.3.2 Operator Instruction

Step by step instruction for BRAC Onnesha Ground Station operation is given below.

1. Turn on all the ground station equipment as mention in the section above.
2. Open the “**HamRadioDeluxe**” software by click a following icon on GS PC desktop.

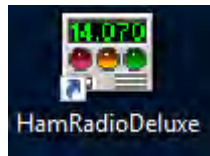

3. After opening the “**HamRadioDeluxe**”, this window will appear.
  1. Check on Rotator and Satellite Tracking.
  2. Confirm the port number of radio and click “Connect”.

The screenshot shows the HamRadioDeluxe software window. The title bar reads 'Connect: Unregistered - Registration is Free!'. Below the title bar, there is a menu bar with 'New', 'Preset', 'Serial Ports', and 'Help'. A table lists radio presets:

Company	Radio	Port	Speed	CI-V Address	CTS	DTR
ICOM	IC-9100	COM3	19,200	7C	-	-

Below the table, there are several options and checkboxes:

- Always connect to this radio when starting HRD
- Start HRD in Full Screen mode
- Digital Master 780
- Logbook
- Rotator
- Satellite Tracking

At the bottom left, there is a 'Connect' button. At the bottom right, there is a 'Remove' button.

**Step 2 - Click -Connect** (with a green box around the Connect button)

**Step 1 - Check -Rotator -Satellite Tracking** (with a green box around the Rotator and Satellite Tracking checkboxes)

4. The Radio Control, Satellite Tracking and Rotator software should appear on monitor.

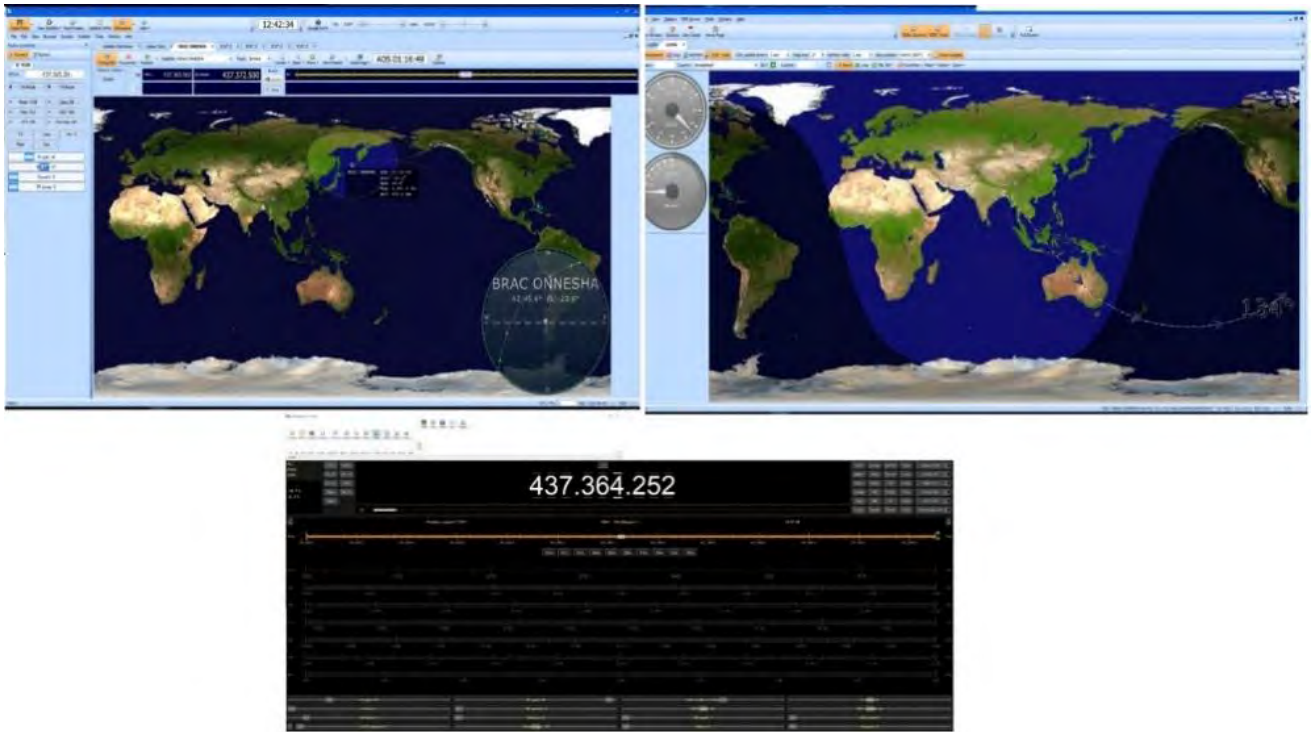

5. Satellite Tracking Software operation

- Select the satellite name
- Click “Tuning Dial”
- Check “RX” check box
- After this step the ICOM transceiver should show same frequency that display in GS PC monitor and the rotator should able to track the satellite.



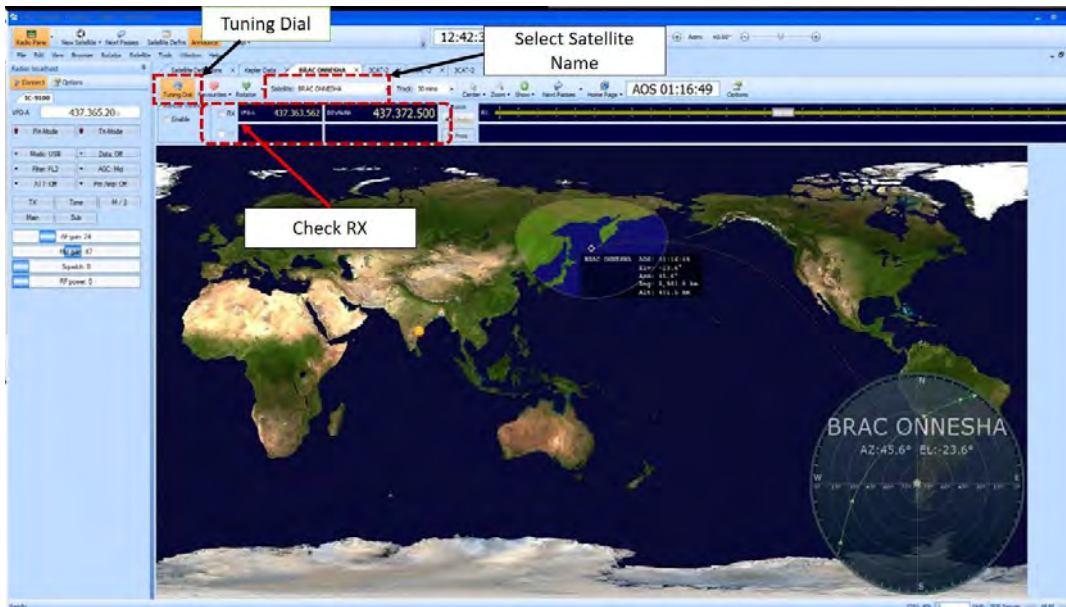

## 6. Rotator Control operation

- Check a setting value
  - Rotator must be “Yaesu GS-232B Az/EI ”
  - Select the correct port number
  - Select connection speed at 9600 bps
- Click “Connect”
- Click “DDE: Connect”
- Click “DDE: Track”

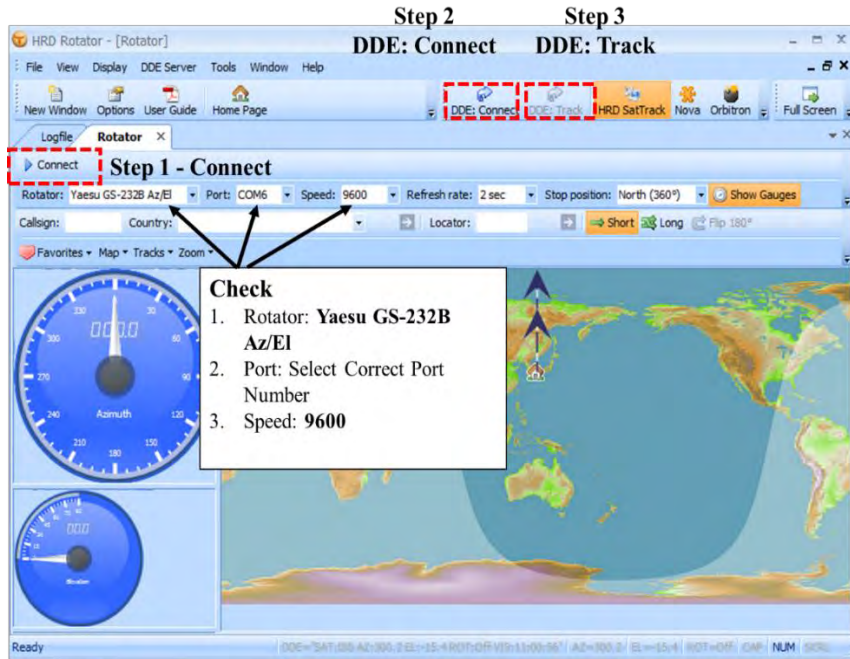

7. Ground station setting for receive CW beacon

- Set the transceiver frequency and mode to CW mode by click “Freq” button.
- Double click on CW mode frequency, then the transceiver should change to CW frequency

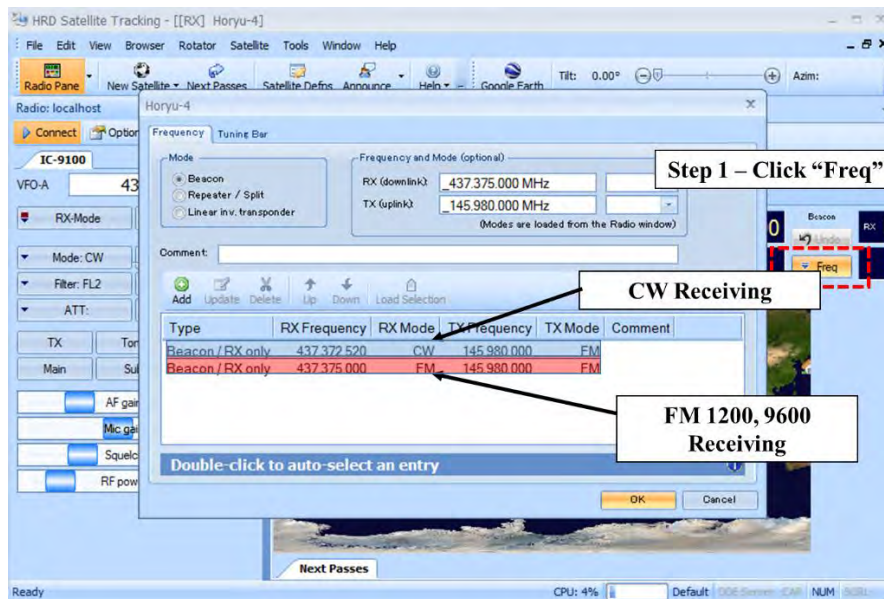

- Open CWget CW Morse decoder
- Select “Auto Threshold” and “AutoGTM”. Then the software should be able to decode CW beacon signals that contain the Real Time House Keeping (RTHK) from the BIRDS satellites.

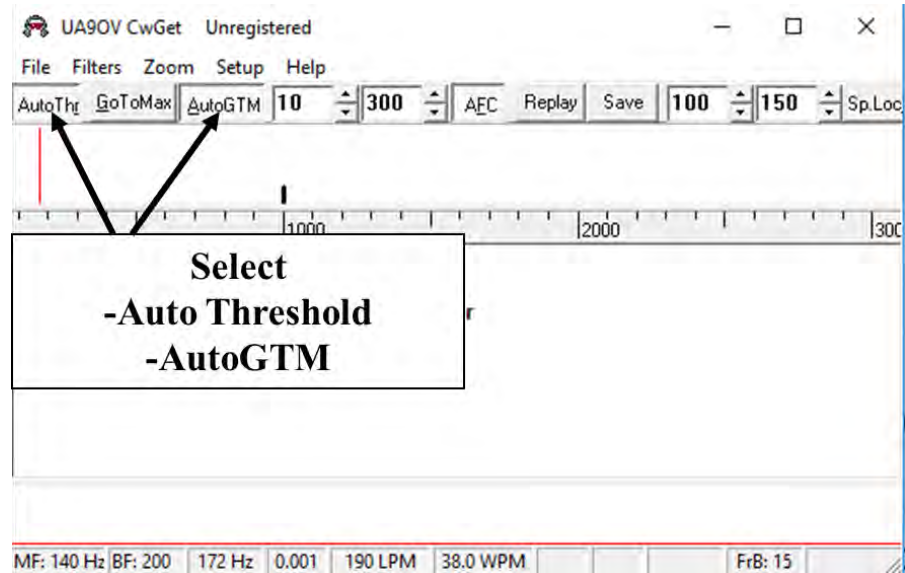

- Copy the RTHK data from CWget software and fill into BIRDS CW Analysis Software.
- Select the folder for save the analyze data.
- Click “Analysis”, then an analyzed data will show on the software screen.

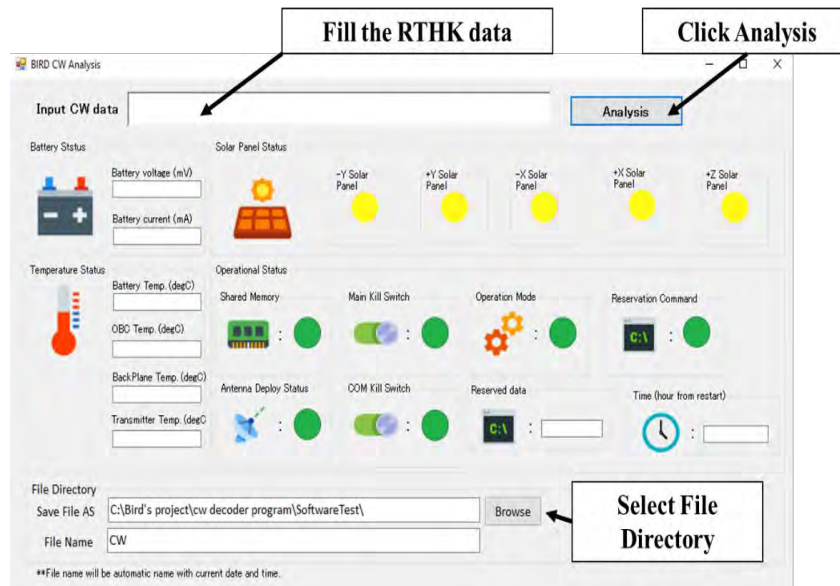

8. Ground station setup to receive FM downlink mission data and send uplink command to the BIRDS satellites.

- Set the transceiver frequency and mode to FM mode by double click at FM mode frequency.

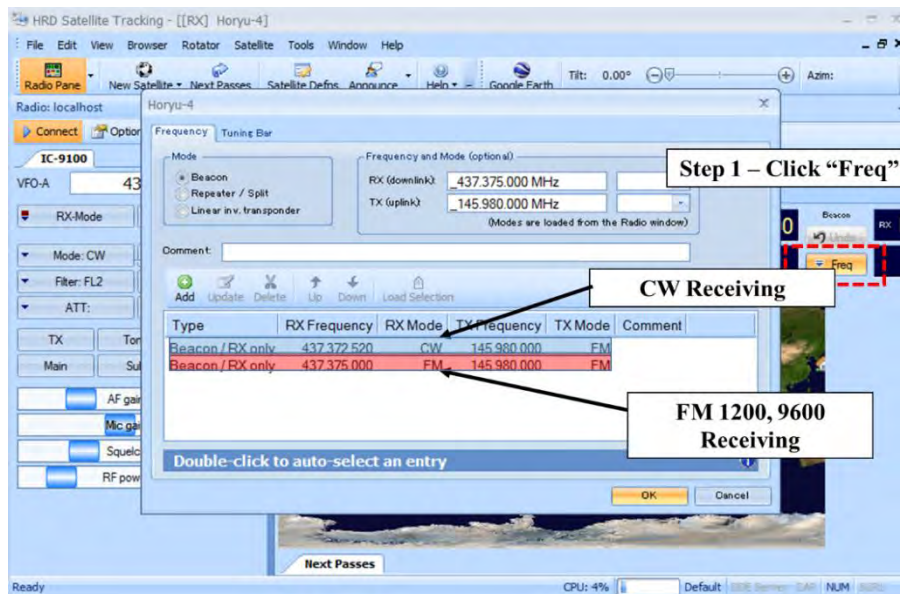

- Enable the data mode of the ICOM transceiver to support 9600 bps communication mode.

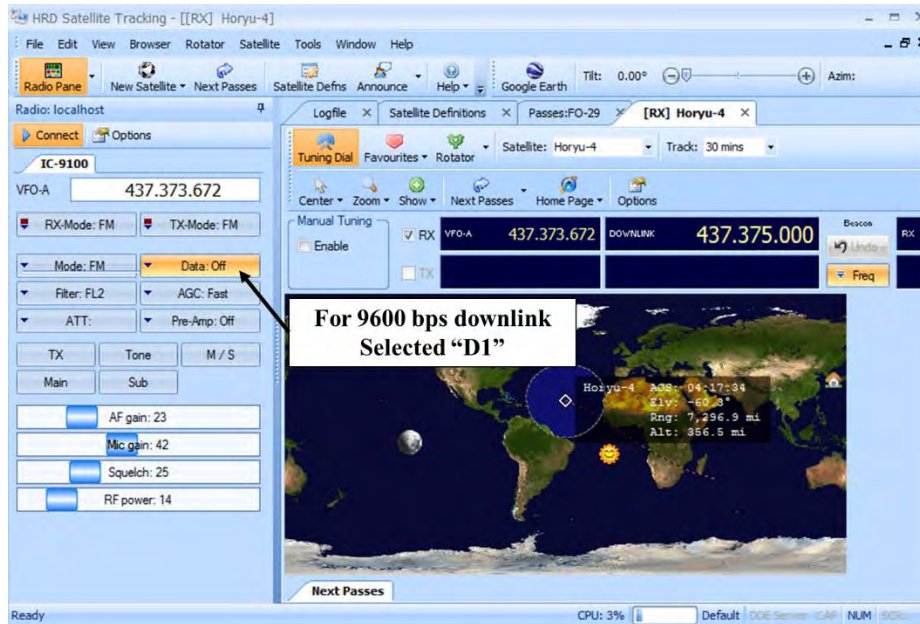

### To Send Command:

- Open BIRDS Uplink and Downlink software
- Set the destination satellite and fill uplink command
- Click “Transmit” to send command to the satellite.

### To Receive Downlink Data:

- After GS received data and display on the terminal, click “save” data for the post processing.

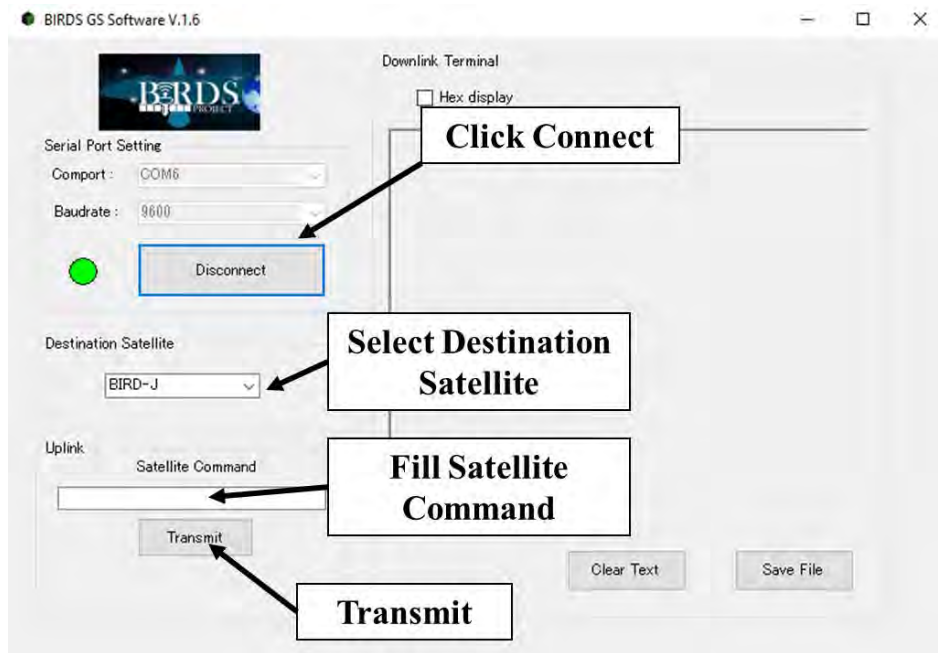

### Analyze the Satellite Log:

1. After receive the satellite log data, then click “analysis” button.
2. The satellite log data will save in the same folder with the BIRDS GS software.

## **3 Antenna Theory**

Antennas are used to transmitting or receiving Electromagnetic waves. It is the most critical component for wireless communication system.

### **3.1 Basic Parameters of Antenna**

#### **3.1.1 Frequency:**

All electromagnetic waves have the same speed in air or in space. This is the speed of light which we represents as 'c'.

$$c = 3 \cdot 10^8 \text{ m/s}$$

The frequency of a wave is the number of cycles the wave completes in one second. Which is mathematically written as:

$$F = 1/T$$

The relation between frequency, wavelength and speed of light is:

$$c = f * \lambda$$

Frequency is the measurement of oscillation of a wave. Frequency is so important because all the waveforms are actually just the sum of simple sinusoids of different frequencies.

#### **3.1.2 Radiation pattern:**

Radiation pattern is how power is radiated from an antenna. Based on the radiation pattern an antenna can be isotropic, unidirectional and directional.

- Isotropic: Radiation is same in all direction.
- Omni directional: Radiation is isotropic in a single plane.
- Directional: Single peak direction in a radiation pattern.

**3.1.3 Directivity:** Directivity is the measurement of how directional antenna's radiation pattern is. If an antenna's radiation is isotropic it equally radiates in all direction it would have zero directivity. Directivity is referred to directivity of the peak.

### **3.1.4 Antenna Gain:**

The term Antenna Gain describes how much power is transmitted in the direction of peak radiation to that of an isotropic source.

### **3.1.5 Bandwidth:**

Bandwidth of an antenna is the difference between highest and the lowest frequency over which antenna can transmit or receive energy.

### **3.1.6 Antenna Temperature:**

This parameter is used to measure the noise produced by the antenna.

### **3.1.7 Antenna Impedance:**

Antenna impedance relates the voltage to the current at the input to the antenna. If an antenna has an impedance of 50 ohms. It means that if a sinusoidal voltage is applied at the antenna terminals with an amplitude of 1 Volt, then the current will have an amplitude of  $1/50 = 0.02$  Amps. Since the impedance is a real number, the voltage is in-phase with the current.

Ideally we take 50 ohms impedance as a standard for all antenna.

Antenna Impedance is very important as the antenna impedance must match the impedance of the transmission line in order to transmit or receive signals. If the Antenna impedance is not equal to the impedance of the transmission line then signal will not be radiated or received.



When antenna impedance is equal to transmission line impedance then the impedance is "matched".

### **3.1.8 Reflection Co-efficient $\Gamma$ :**

The ratio of the reflected voltage amplitude to that of the forward voltage amplitude is the voltage reflection coefficient.

$$\Gamma = (Z_l - Z_0) / (Z_l + Z_0)$$

The reflection coefficient is usually denoted by the symbol gamma. The magnitude of the reflection coefficient does not depend on the length of the line, only the load impedance and the impedance of the transmission line. If there is proper impedance matching then there is no mismatch loss and all power is transferred to the load. If the impedances do not match then this will lead to most of the power to be reflected away from the load.

### **3.1.9 VSWR:**

It stands for voltage standing wave ratio. It indicates how well the antenna impedance is matched. For an ideal antenna with reflection coefficient zero that is no power is reflected back to the antenna, VSWR is 1. This is the minimum value of the parameter. Typically it is considered that if the VSWR is less than 2 then it is considered good. The more it is closer to 1 the better the antenna is matched and the better the antenna will perform. If VSWR is greater than 2 then two problems arise:

- A. More power is reflected back to antenna rather than transmitted thus reducing the power of the transmitted signal.
- B. Reflected power damages the radio which is transmitting the signal.

### **3.1.10 Loss due to electrical wave propagation delay**

Electrical wave propagation in wire is about 95% to 97% the speed of light. Since wavelength is most commonly used for building antennas which involve conducting the wave from air into the wire and vice versa, the calculation is adjusted assuming the slower propagation in an unshielded conductor. So there is a natural electrical loss of 3% to 5%. For our calculations we have considered 5% loss.

## **3.2 Background Information**

There are many types of antenna few of them are listed below which have been proposed for portable ground station application:

1. Yagi-Uda Antenna
2. QFH Antenna
3. Lindenblad Antenna
4. V- Dipole Antenna

The types of antennas varies through frequency, gain, impedance, polarization, field regions and most importantly radiation pattern.

**3.2.1 Yagi-Uda Antenna:** Yagi-Uda antenna also known as Yagi antenna was first introduced and described in Japanese in articles published in the journal of I.E.E of Japan by S. Uda, a professor of the Tohoku Imperial University in 1926. But most widely read and circulated article was published by H. Yagi a colleague of Professor Uda, describing the operation of same radiator in English. It was first widely used during World War II in radar system by British, Germans, US and Japanese. Later it became more popular and commercially used for T.V.

reception. Due to its directional radiation pattern and high gain it is used widely by satellite engineers for Nano-satellite ground stations worldwide.

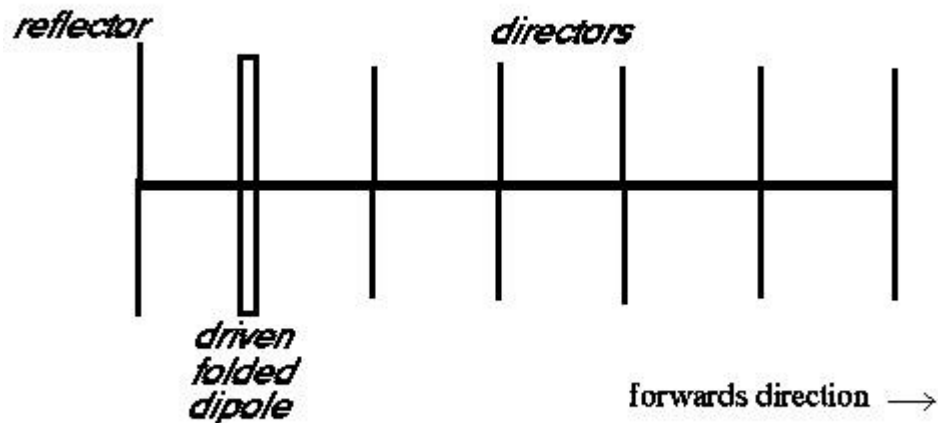

Figure: Yagi-Uda Antenna

It usually consists of three parts

Reflector

Driven element or dipole

Directors

Driven element is the only element that is connected to the feed line. Thus all other elements are considered parasitic. The director and reflector of the antenna help enhance the radiation and direction of the radiation. The reflector is slightly longer than the driven element.

**3.2.2 QFH Antenna:** Quadrifilar Helix Antenna also known as QFH antenna is widely used for Ultra high frequency (300 MHz to 3 GHz) and Microwave communications. The design first sited at McConnell, C.Nicoles, S.Barta,"QUADRIFILAR HELIX ANTENNA." U.S. Patent 5,635,945, issued June3, 1997. It is widely used by the Ham-operators worldwide to receive weather satellite images.

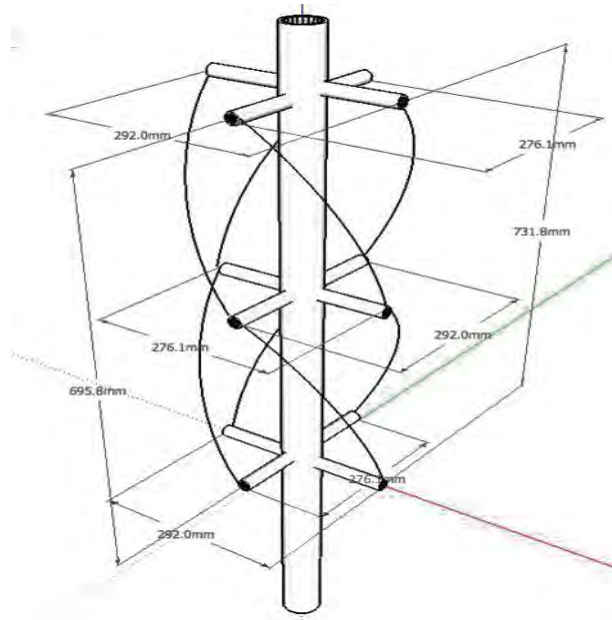

Figure: QFH Antenna

As the polar orbiting satellites moves from horizon to horizon its polarization towards earth also change. So it is more feasible to use QFH antenna as it is properly polarized in all directions. The diameter of a QFH antenna depends upon the frequency in which it is operating.

**3.2.3 Lindenblad Antenna:** Lindenblad antenna was designed by Nils Lindenblad of the Radio Corporation of America (RCA) around 1940 (G. Brown and O. Woodward Jr. Circularly polarized Omnidirectional Antenna, RCA Review, Vol 8, no. 2, June 1947, pp 259-269). It is circularly polarized and has an omnidirectional radiation pattern which makes it ideal for low earth orbit (LEO) Amateur Radio satellites. The original design was developed for television broadcasting industry but start of World War II interrupted Lindenblad's TV antenna work. Later, George Brown and Oakley Woodward while working with signal fading of ground to air radio links at airport, realized that using a circular polarized antenna may reduce or eliminate fading of signal (G. Brown and O. Woodward Jr. Circularly polarized Omnidirectional Antenna, RCA Review, Vol 8, no. 2, June 1947, pp 259-269).

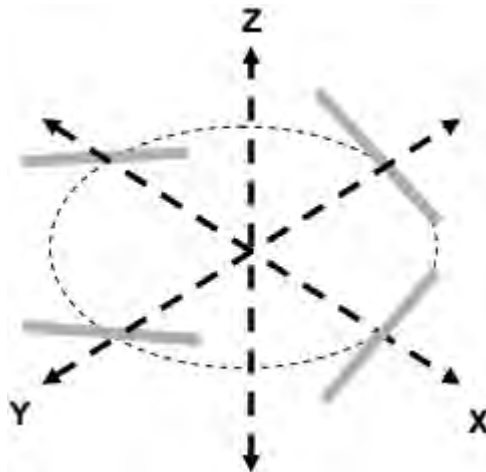

Figure: Lindenblad Antenna Concept Drawing

In the Figure four dipoles are used in a Lindenblad Antenna. They are spaced in the same distance from the center.

**3.2.4 V-Dipole Antenna:** V dipole antenna is also known as horizontal dipole antenna.

It has a horizontal polarization and Omni directional radiation pattern. This design is more popular for inverted v dipole antenna. Where the two sides are bent down to the ground at an angle of 120 to 90 to create an inverted v dipole antenna. This antenna is very popular among the ham operators around the world as it has horizontally polarized.

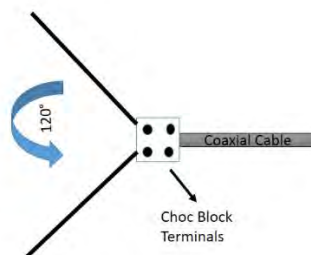

Figure: V-Dipole Antenna (Top view)

If we arrange the dipole into horizontal 'V' shape most of its radiation will be directed skyward. As most of the terrestrial signals are broadcast in vertical polarization, so this design can help significantly to reduce interference. A single dipole is used to design such antenna.

## **4 Experimentation**

### **4.1 The portable ground station setup**

Portability of satellite ground station is essential for many cases especially if someone is living in a Radio Frequency dense area. The requirements of such receive only satellite ground station is ventured more often by researchers, amateur radio operators and hobbyist to receive signals from satellites better with less environmental noise. The setup used for this portable ground station is very linear and is described below:

#### **4.1.1 Hardware:**

The system uses the following hardware:

- Antenna
- Kenwood FM Tribander TH-F6 handheld radio
- Laptop
- Cables for connection

#### **4.1.2 Software:**

For the purpose of portable ground station the software used are as follows:

- Orbitron for satellite tracking
- WXtoImg for decoding NOAA satellites
- CwGet for decoding CW
- HDSDR for viewing the spectrum

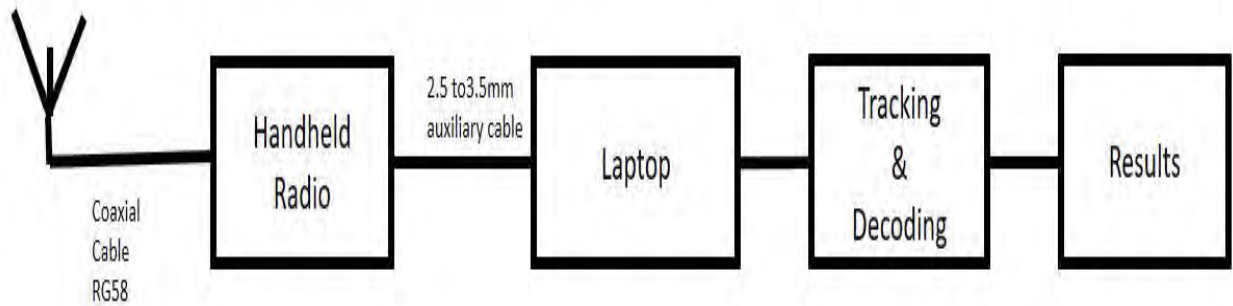

### Portable Ground Station

The portable ground station starts with the antenna. The antenna is the first thing that is to be considered for this ground station setup. The antenna is to be chosen accordingly keeping in mind the frequency at which the user is willing to downlink the data. The antenna of that frequency is then connected to the Kenwood FM Tribander TH-F6 handheld radio by a SMA Male connector. The frequency of the downlink is set in the handheld radio and the output of it is taken from SP 2.5mm output pin to the laptop's 3.5mm microphone input pin. So a 2.5mm to 3.5mm auxiliary cable is made. Then the output of the handheld is taken to the laptop through this cable and this becomes the input for the decoding software. The decoding software decodes the signal and after the satellite pass is over it stops decoding and process the data to view the final result.

As it can be easily seen that the portable ground station uses very linear setup but it is very efficient and very much portable system. The ground station can be used to receive data from High Frequency, Very High Frequency and Ultra High Frequency spectrum just by changing the antenna and by changing the decoding software. As frequency and mode of signal vary only the antenna and the decoding software is to be used as per requirement of the user. This system can only receive signal that is it cannot transmit signals.

For the purpose of demonstration we have constructed and used different antennas for Very High Frequency and Ultra High Frequency for transmission of SSTV (Slow Scan Television) from different distances and received the signal with these Antennas.



## 4.2 Design and Calculation:

### 4.2.1 Yagi-Uda Antenna:

**Materials:** Polyvinyl Chloride (PVC) pipe, 6mm diameter aluminum rod, RG58 coaxial cable.

#### **Calculation and Construction of antenna:**

We have been designing a Yagi-Uda antenna for 436MHz. All calculation have been done in S.I unit system.

<b>Frequency = 436MHz</b>
$\lambda = c / f = 0.6881\text{m}$

#### **Length of elements:**

Half wave length calculation shown below considering electrical wave propagation delay.

<b>Name of element</b>	<b>Formula</b>	<b>436MHz(m)</b>
<b>Reflector</b>	$.495 * \lambda$	<b>0.34061</b>
<b>Radiating element</b>	$.473 * \lambda$	<b>0.32547</b>
<b>Director1</b>	$.440 * \lambda$	<b>0.30276</b>
<b>Director2</b>	$.435 * \lambda$	<b>0.2993</b>
<b>Director3</b>	$.430 * \lambda$	<b>0.2958</b>
<b>Director4</b>	$.425 * \lambda$	<b>0.2924</b>
<b>Director5</b>	$.420 * \lambda$	<b>0.2890</b>
<b>Director6</b>	$.415 * \lambda$	<b>0.2856</b>
<b>Director7</b>	$.410 * \lambda$	<b>0.2821</b>
<b>Director8</b>	$.405 * \lambda$	<b>0.2786</b>

Yagi-Uda antennas are half wave length in total length but during construction we use quarter wave length since the element half wave length is divided into two and connected to the boom via insulation.

As we have considered to use metallic boom for both the antennas we have to be careful to insulate the elements properly from the boom. We plan to begin construction as soon as the simulation is completed. We have planned to use either aluminum tube or thick copper wire for elements (reflector=10mm, others=5mm). We prefer to use aluminum or copper wires.

The Yagi-Uda antenna consists of 2 parts:

- Antenna elements
- Antenna boom

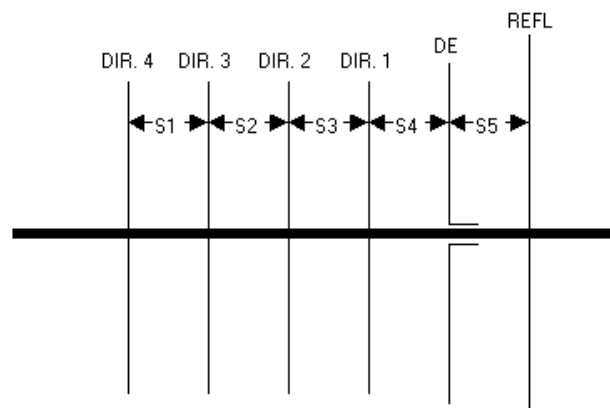

Figure: Different elements of the Yagi-Uda antenna

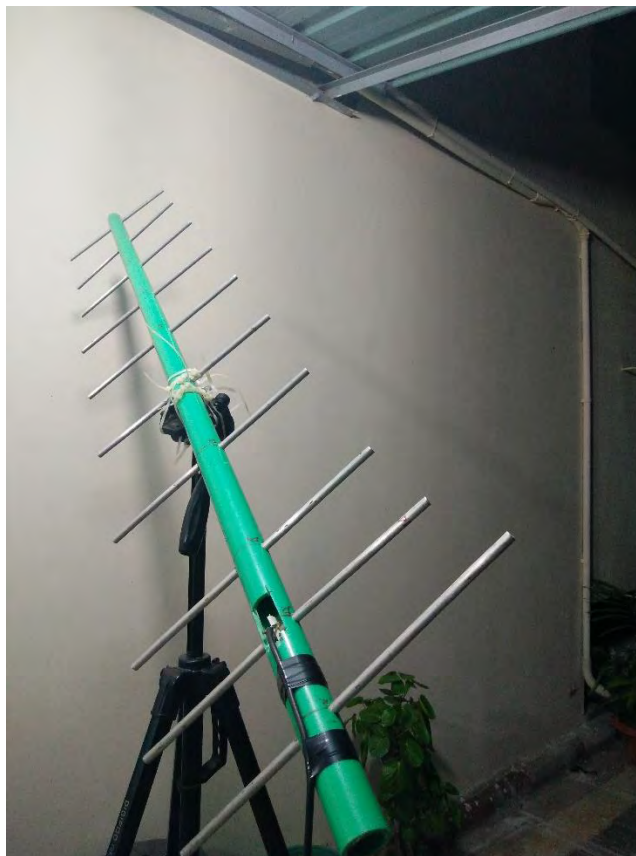

Figure: Yagi-Uda antenna

There are three types of elements:

- Reflector (REFL)
- Driven Element (DE)/ Radiating Element(RE)
- Directors (DIR)

The Reflector is at the back of the antenna behind driven element.

The Driven Element is where the signal is intercepted by the receiving equipment and has coaxial cable attached that takes the received signal to the transceiver or vice-versa.

### 4.2.2 QFH Antenna:

**Materials:** Polyvinyl Chloride (PVC) pipe, coaxial cable RG58, coaxial cable RG8.

#### **Calculations and Construction:**

We have designed the Quadrifilar Helix Antenna for 137.5MHz. All calculations have been done in S.I unit system.

Number of turns: 0.5

Length of one turn: 1 wavelength

Bending radius: 38.1

Conductor diameter: 5mm

Width/Height ratio: 0.44

Wavelength: 2181.8 mm

Compensated wavelength: 2334.5 mm

Bending correction: 16.3 mm



Figure: QFH Antenna

### Larger loop

<u>Total length</u>		2395.2 mm
<u>Vertical separator</u>		903.3 mm
<u>Total compensated length</u>		2460.6 mm
<u>Compensated vertical separation</u>		827.1 mm
<u>Antenna height</u>	<b>H1=</b>	743.1 mm
<u>Internal diameter</u>	<b>Di1=</b>	321.9 mm
<u>Horizontal separator</u>	<b>D1=</b>	326.9 mm
<u>Compensated horiz. separation</u>	<b>Dc1=</b>	250.7 mm

### Smaller loop

<u>Total length</u>		2276.1 mm
<u>Vertical tube</u>		859.6 mm
<u>Compensated total length</u>		2341.5 mm
<u>Compensated vertical tube</u>		783.4 mm
<u>Antenna height</u>	<b>H2=</b>	707.1 mm
<u>Internal diameter</u>	<b>Di2=</b>	306.1 mm
<u>Horizontal separator</u>	<b>D2=</b>	311.1 mm
<u>Compensated horiz. separator</u>	<b>Dc2=</b>	234.9 mm

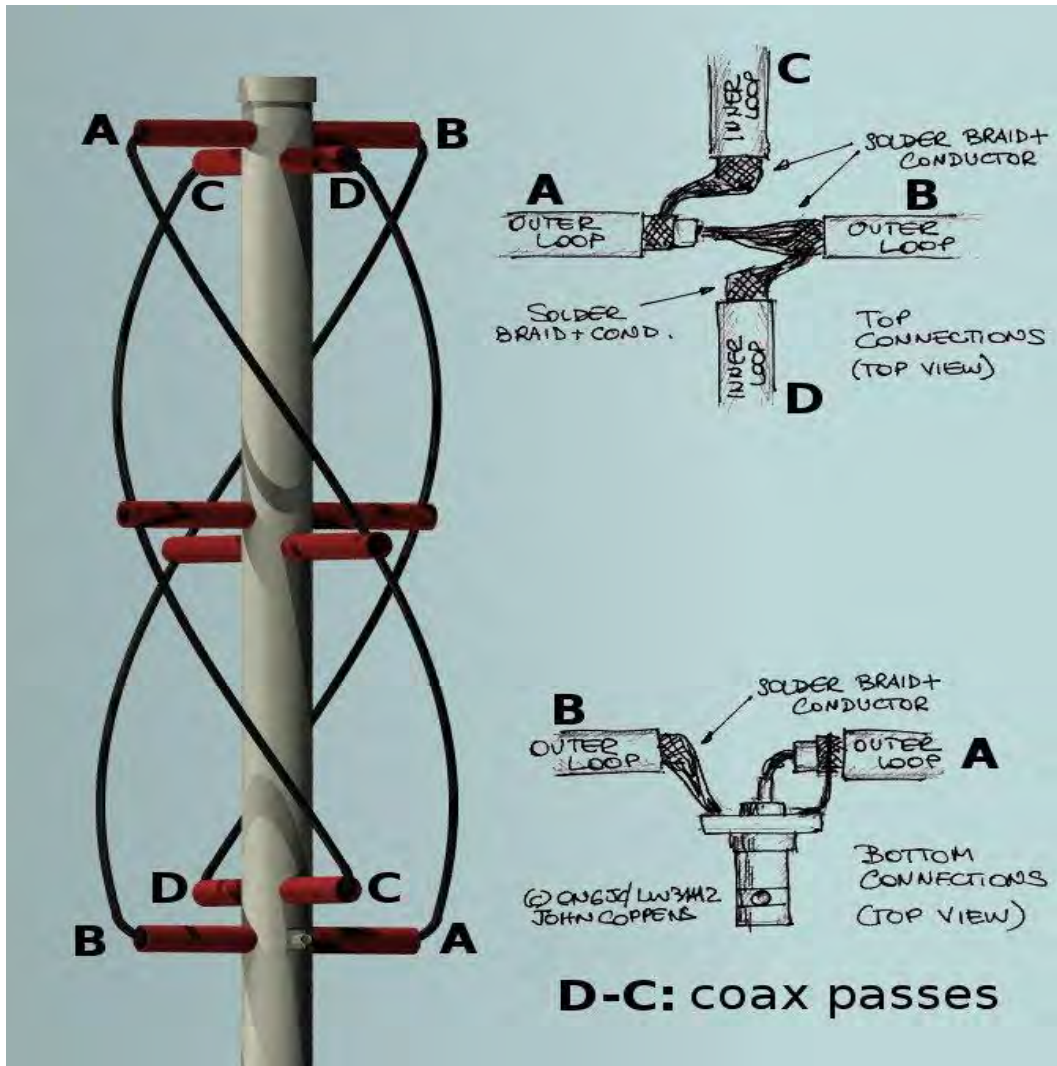

### Length of one turn

A few variations of the antenna exist. Normally the circumference (length of the loop) is 1 wavelength, but 1.5 wavelength and 2 wavelength versions exist.

### Bending diameter

It is impossible to bend the corner abruptly at 90 degrees, this value is needed for the calculations. It's measured from the bending center to the center of the tube.

### **Conductor diameter**

External diameter of the tube or coax cable is the conductor diameter.

### **Diameter/height ratio**

Most frequently this ratio is 0.44, but slightly lower values (0.3 to 0.4) give better horizon coverage.

### **Wavelength**

Wavelength, corresponding to the selected frequency.

### **Compensated wavelength**

Wavelength is compensated according to the conductor diameter that is the diameter of the coaxial cable.

### **Bending correction**

Correction value needed according to the bending diameter of the conductor.

### **Total length**

Total length of the loop, before compensation of wavelength.

### **Total loop compensated length**

Total length of the loop, compensated for the bending effect, and the fact that the loop must be slightly larger (or smaller). This is the amount of tubing necessary for this loop.

### **Compensated vertical separation**

Vertical separation without the 'bends'.

### **Compensated horizontal separation**

This is in fact the horizontal part without the 'bends', and corresponds to the horizontal pipe necessary to support the cable.

### **Antenna height**

Height of the loop twisted is the antenna height.

### **Internal diameter**

The imaginary diameter of the cylinder on which the loop would be wound.

### **4.2.3 Lindenblad Antenna:**

**Materials:** Polyvinyl Chloride (PVC) pipe, coaxial cable RG58, SMA male connector.

#### **Calculation and Construction:**

The Lindenblad Antenna is designed for 436MHz. All the calculations are done in S.I unit system.

**Dipole Length: .3634 m**

**Dipole diameter: 0.008 m**

**Dipole spacing:  $\lambda/3$  m**



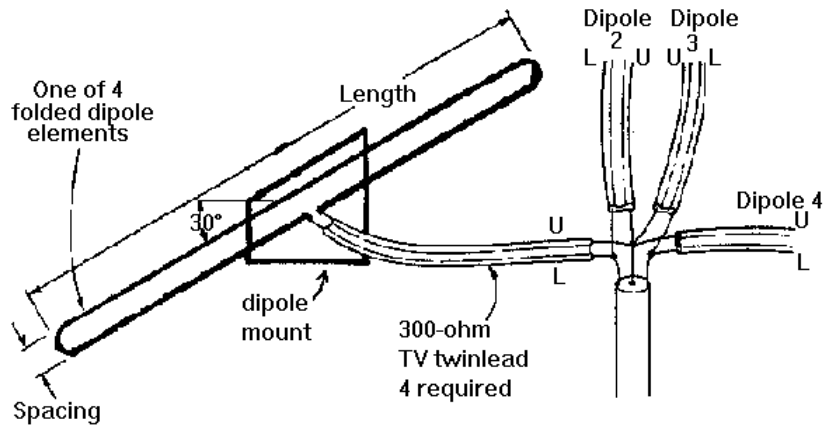

Figure: Feed Line Connection of Lindenblad Antenna.

The four dipoles are slanted 30 degrees to the horizon and oriented 90 degrees to each other in azimuth.



Figure: Lindenblad Antenna.

#### **4.2.4 V- Dipole Antenna:**

**Materials:** Choc Block terminal, Aluminum wire/rod, Polyvinyl Chloride (PVC) pipe, Coaxial cable RG8.



Figure: V-dipole Antenna

#### **Calculations and Construction:**

We have designed the V dipole antenna for 137.5 MHz all calculations have been done in S.I unit.

Wavelength: 2.1818m

Length of total dipole: 1.0909m

Length of each half of dipole: 0.5454m

The angle between each quarter wavelength: 120degree

### 4.3 Simulation of Radiation Pattern

#### 4.3.1 Yagi Uda Antenna Radiation Pattern

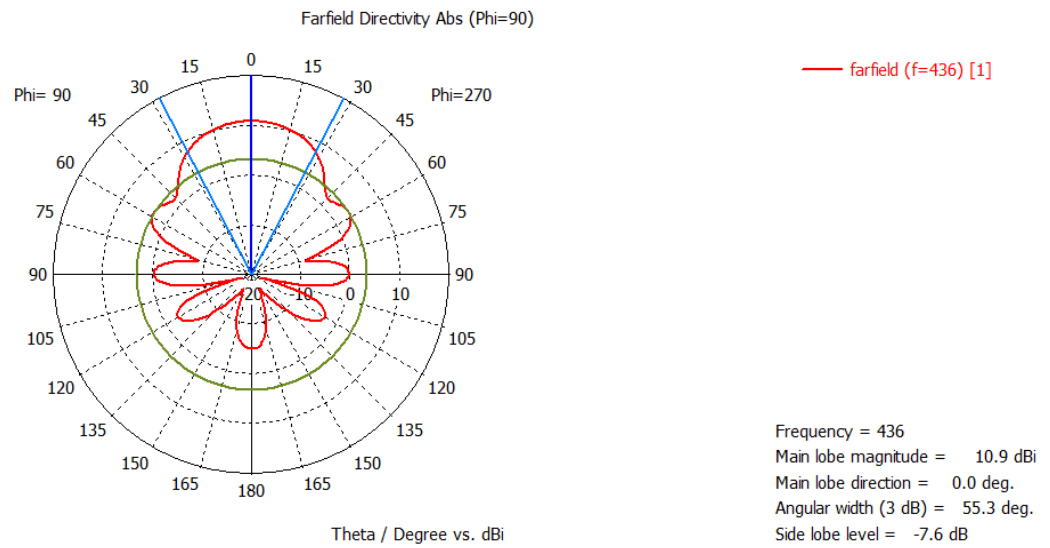
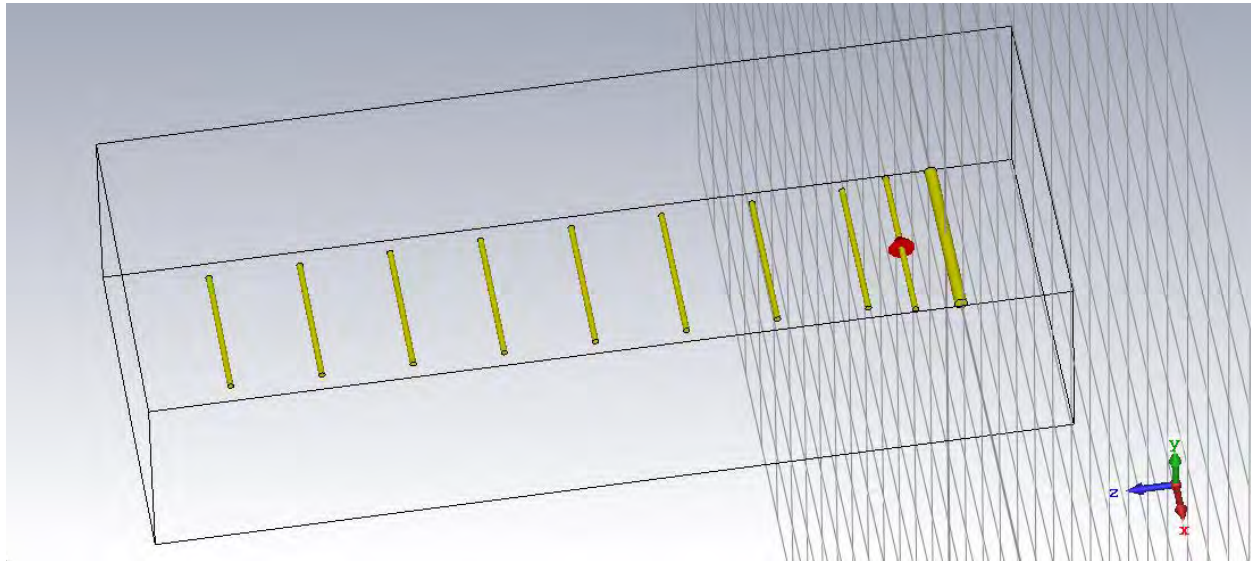

Figure: Yagi Uda antenna 2 Dimensional Radiation pattern plot

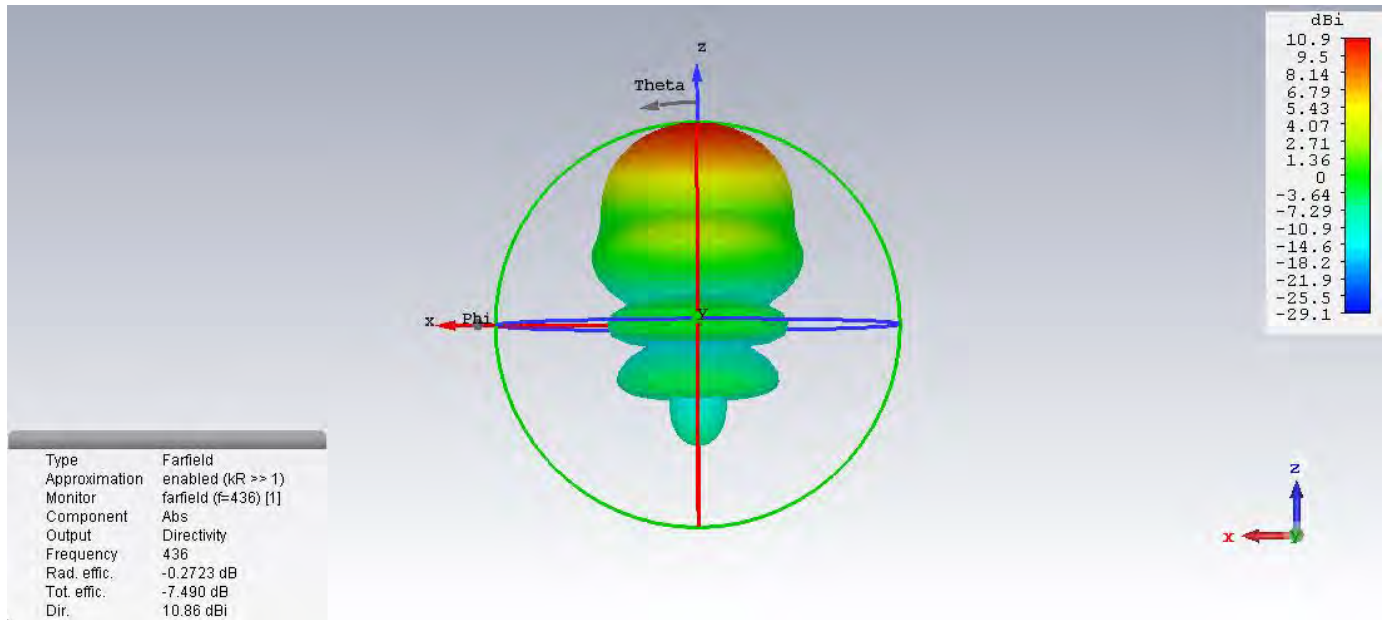
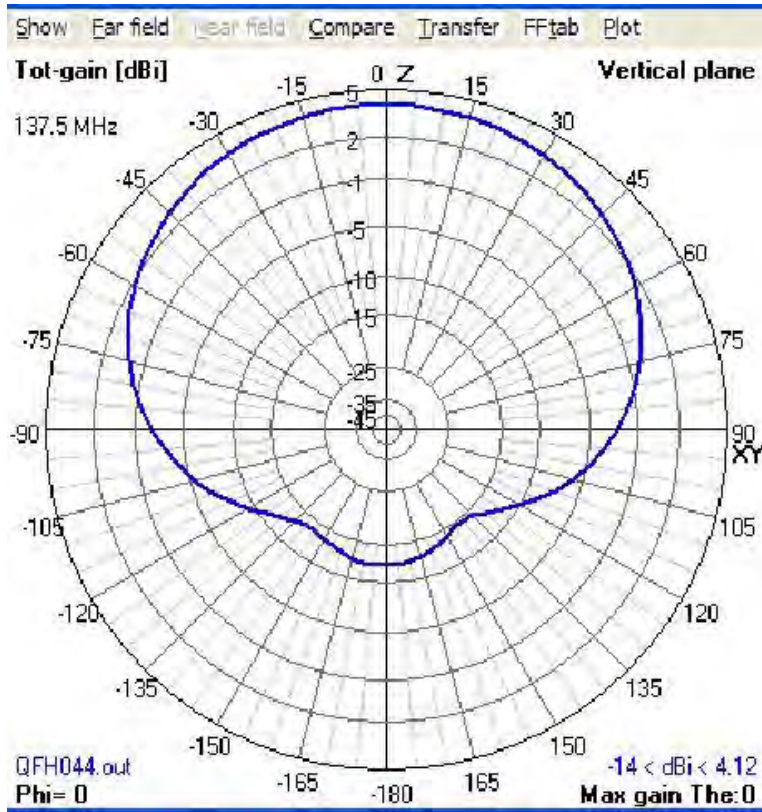
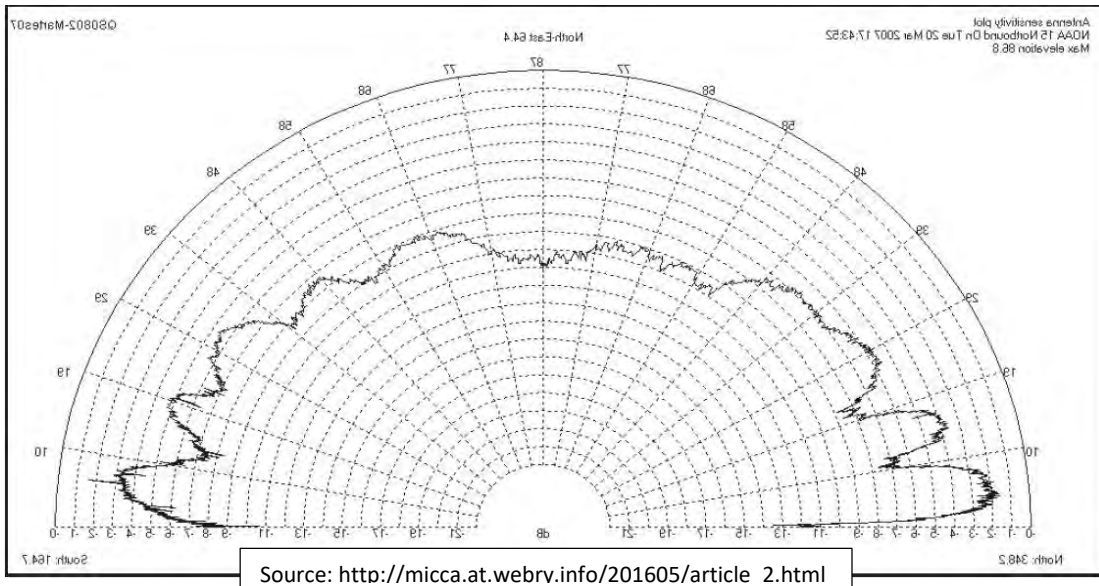

Figure: Yagi Uda antenna 3 Dimensional Radiation Pattern

### 4.3.2 Quadrifilar Helix Antenna Radiation Pattern



### 4.3.3 LINDENBLAD Antenna Radiation Pattern



#### 4.3.4 V Dipole Antenna radiation pattern

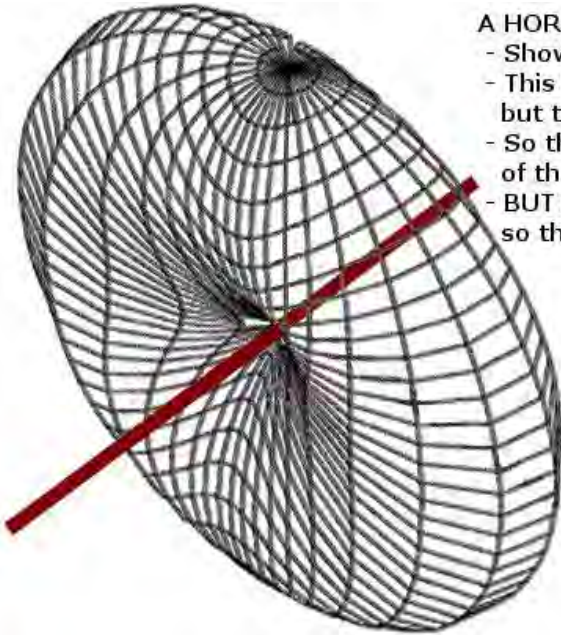

A HORIZONTAL AERIAL (RED)

- Showing the basic Radiation pattern.
- This has the same Radiation as the Vertical but turned 90 degrees.
- So there is a lack of Radiation in the direction of the wires ends.
- BUT it still radiates as generally as the Vertical so there is no big "Gain" that a Beam would provide

Source: <http://charlietango.co.uk/topic/7515945/1/>

\*\*The Yagi antenna radiation pattern has been simulated in CST MICROWAVE STUDIO. The rest of the radiation pattern have been collected for comparison.

# 5 Result and Analysis

## 5.1 Radiation Pattern Simulation Comparison:

From above we can see the radiation pattern of the antennas. By comparing them we can easily say that the Directional antenna Yagi-Uda has much higher gain compared to the later models of omnidirectional antennas. The Yagi antenna has a gain of 10.9 dBi. The QFH, Lindenblad and V dipole antenna had omnidirectional radiation pattern that is they radiate in all direction rather than a single direction. Among these three antennas Lindenblad antenna is the most effective radiation pattern as it is comprised with four dipoles. The V dipole antenna is also good for receiving, but the QFH antenna is not very efficient for receiving signals.

## 5.2 Experiment Data Comparison:

As BRAC University is situated in a Radio Frequency dense area Satellite communication through handmade antennas are tough from here. As this Thesis took place in Dhaka city we decided to test the reception of our handmade antennas by transmitting Slow Scan Television of a picture through a KENWOOD TH-F6 Tribander Handheld radio from distances 800 meter, 6km, and 8.5km. We received the signals from our BRAC ONNESHHA Ground Station in Mohakhali Dhaka with our four antennas, a KENWOOD TH-F6 Tribander Handheld radio and a laptop to decode the SSTV signal received. The Signal is transmitted by “SSTV Encoder” an android app that allows user to convert images to SSTV signals which we used as sources of our transmitting signal through our handheld radio.

Distance: 800 Meter

**Transmitting power: EL**

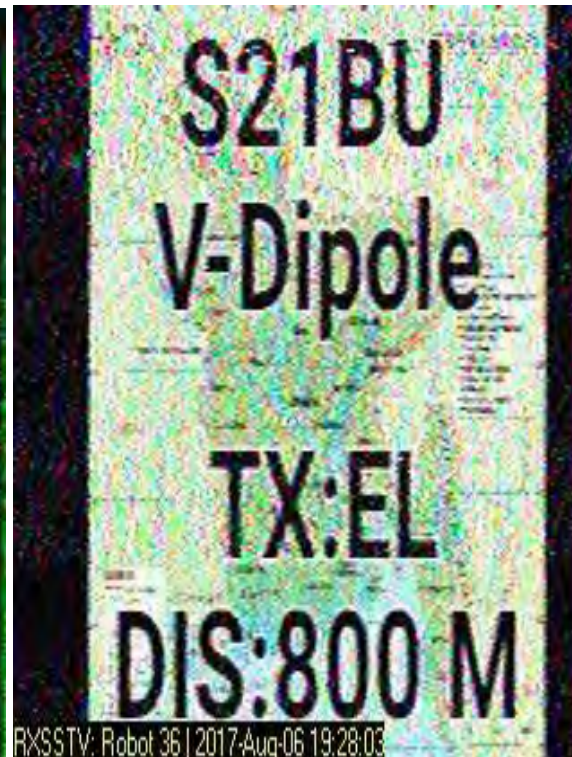



Distance: 800 Meter

Transmitting power: L

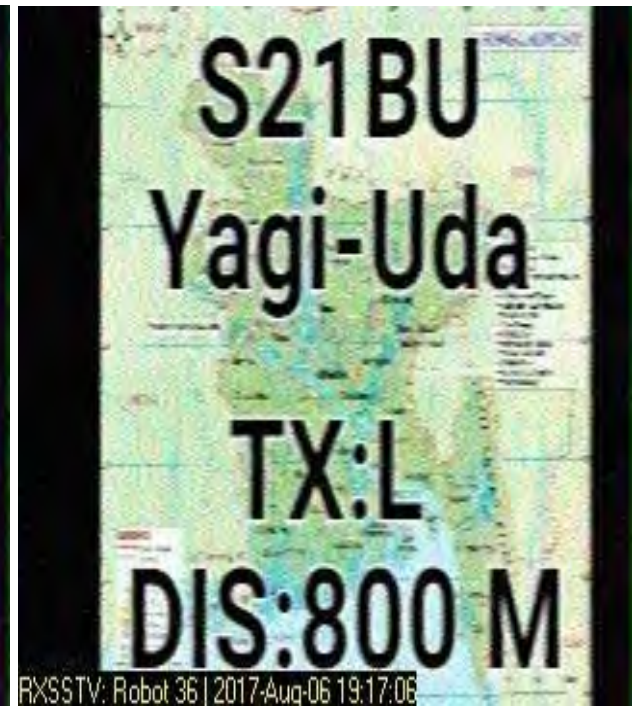
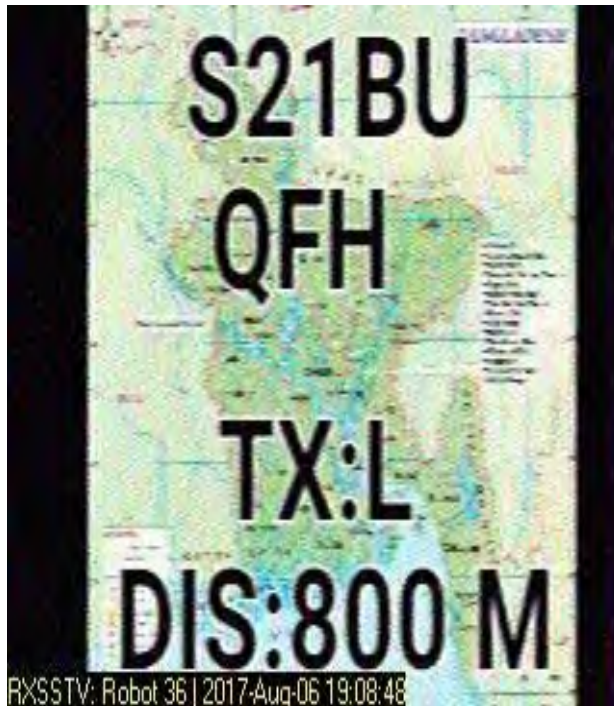

Distance: 800 Meter

Transmitting power: H

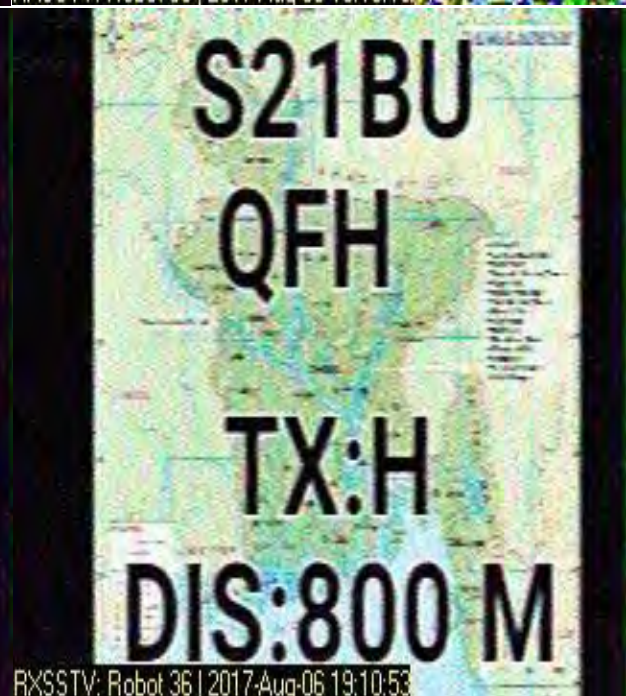
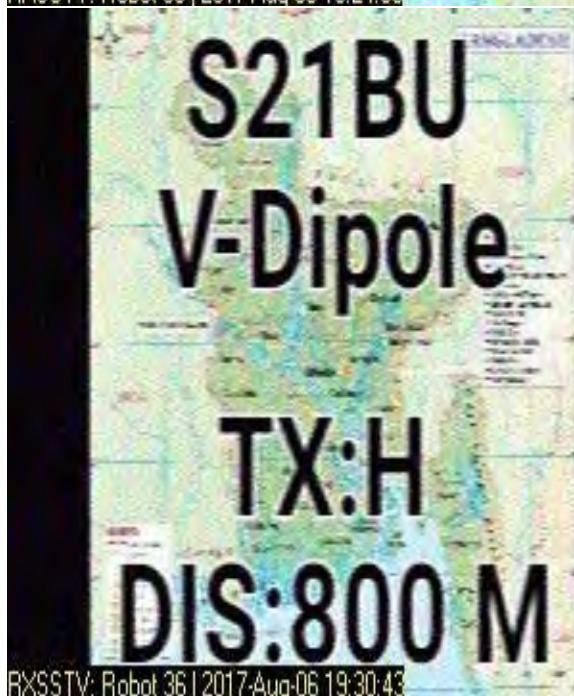
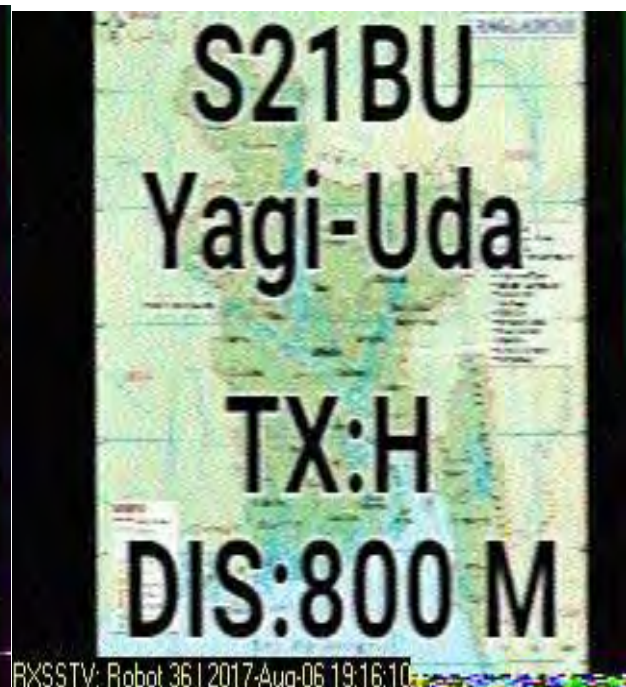

Distance: 6KM

Transmitting power: EL

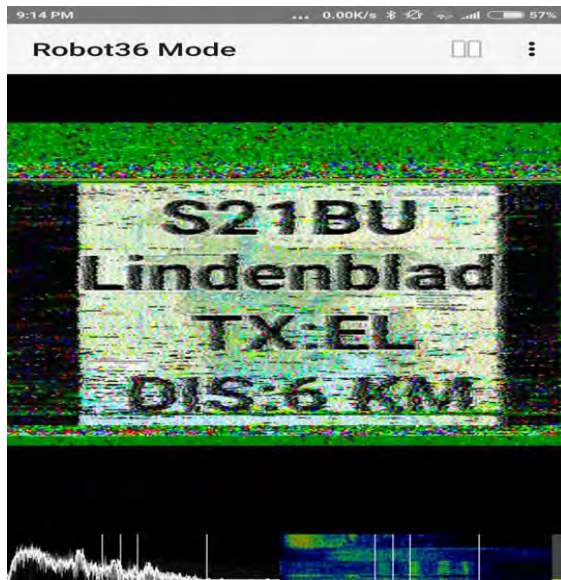

Distance: 6KM

Transmitting power: L



Distance: 6KM

Transmitting power: H

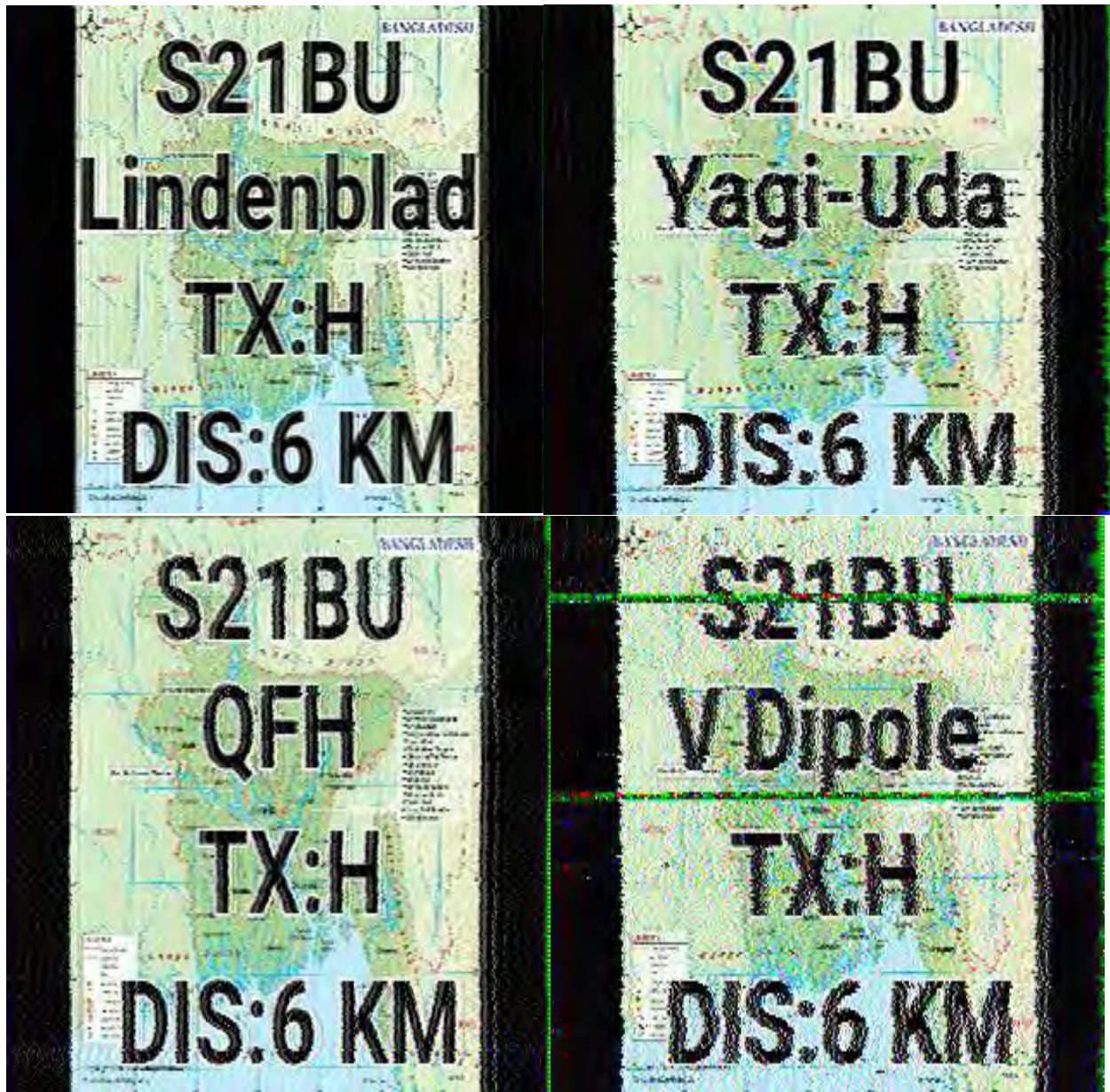

Distance: 8.5KM

Transmitting power: EL



Distance: 8.5KM

Transmitting power: L

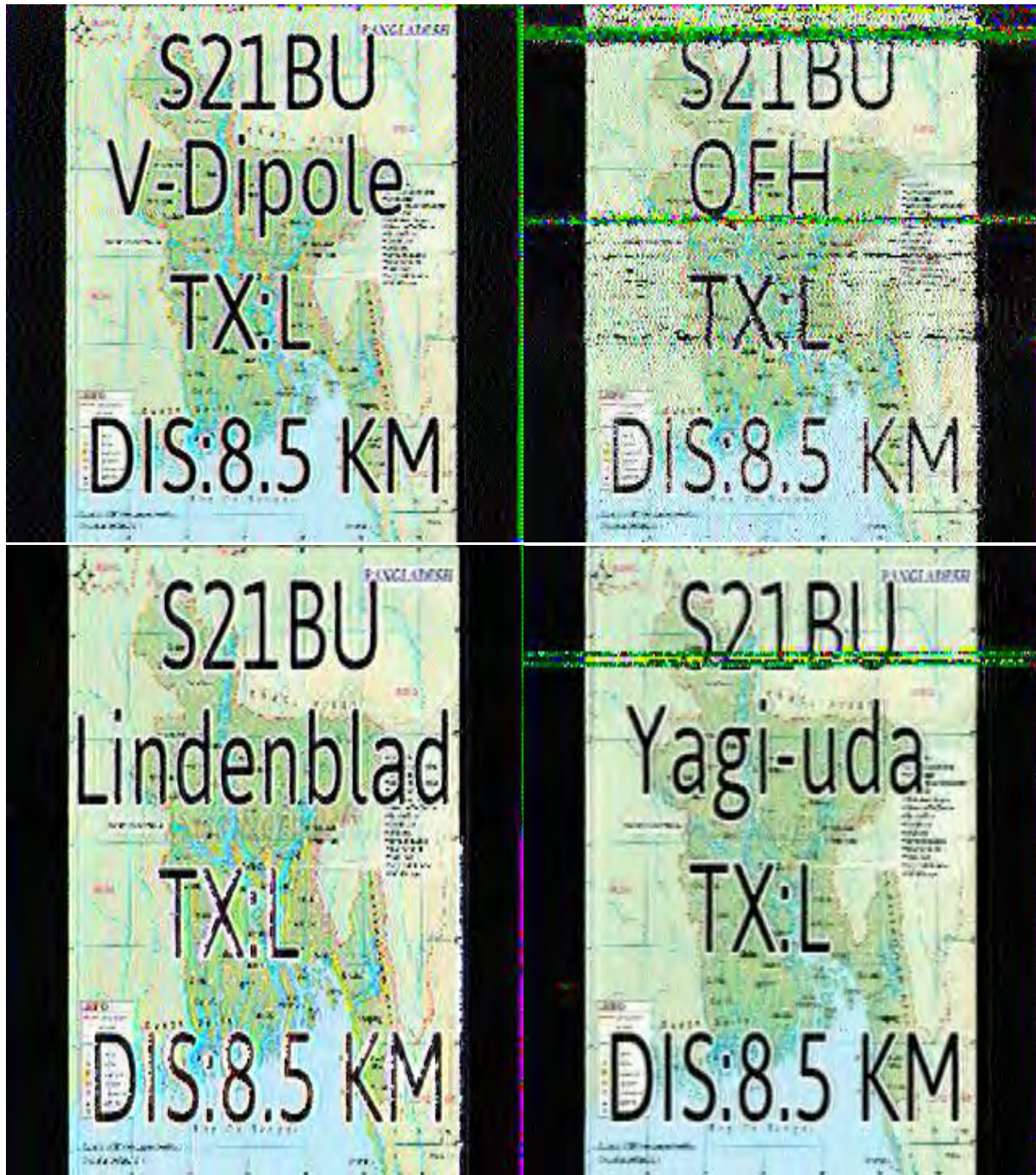

Distance: 8.5KM

Transmitting power: H





### Signal Strength Scale

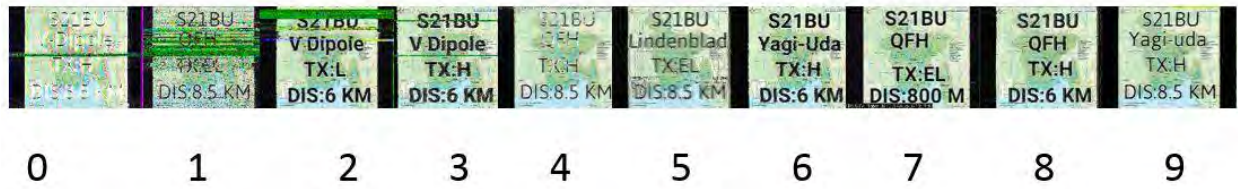

#### For Graph Plot

**Blue:** Yagi-Uda

**RED:** V-Dipole

**Yellow:** QFH

**Violet:** Lindenblad

**Table: EL Transmission Mode**

Distance	800	6000	8500
Yagi	8	5	7
V Dipole	7	5	6
QFH	7	3	1
Lindenblad	7	3	5

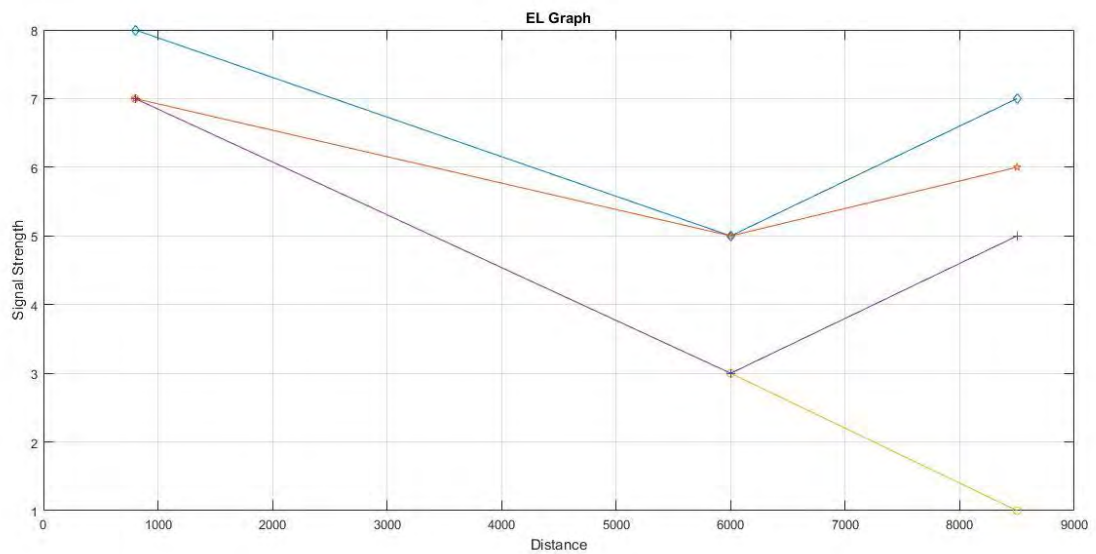

**Figure: Distance vs Signal Strength graph in EL Mode**

**Table: L Transmission Mode**

Distance	800	6000	8500
Yagi	8	5	7
V Dipole	8	2	7
QFH	7	4	3
Lindenblad	8	7	8

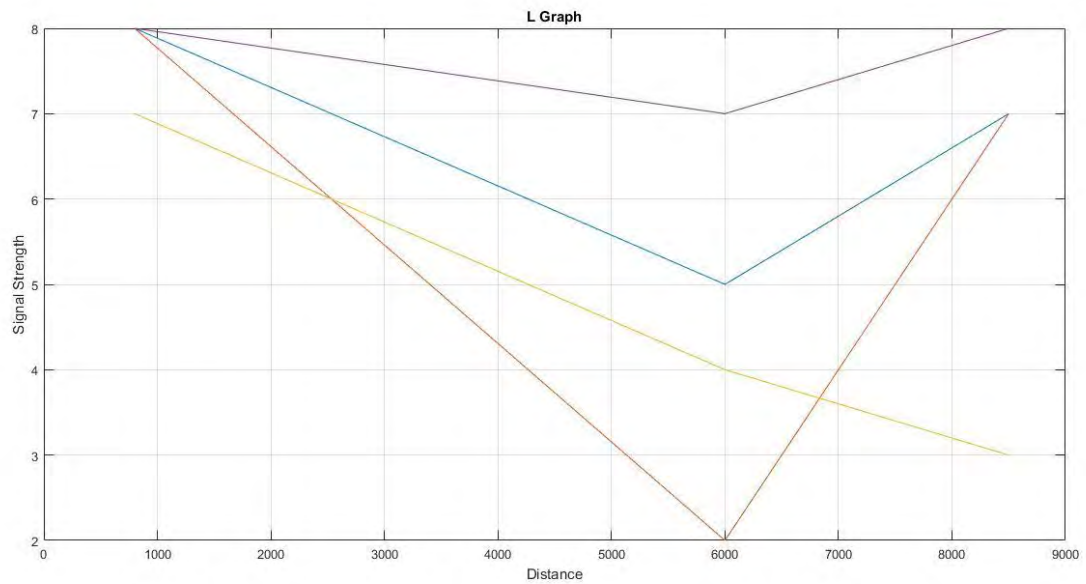

**Figure: Distance vs Signal Strength graph in L Mode**

**Table: H Transmission Mode**

Distance	800	6000	8500
Yagi	9	6	9
V Dipole	9	3	0
QFH	8	5	5
Lindenblad	9	8	8

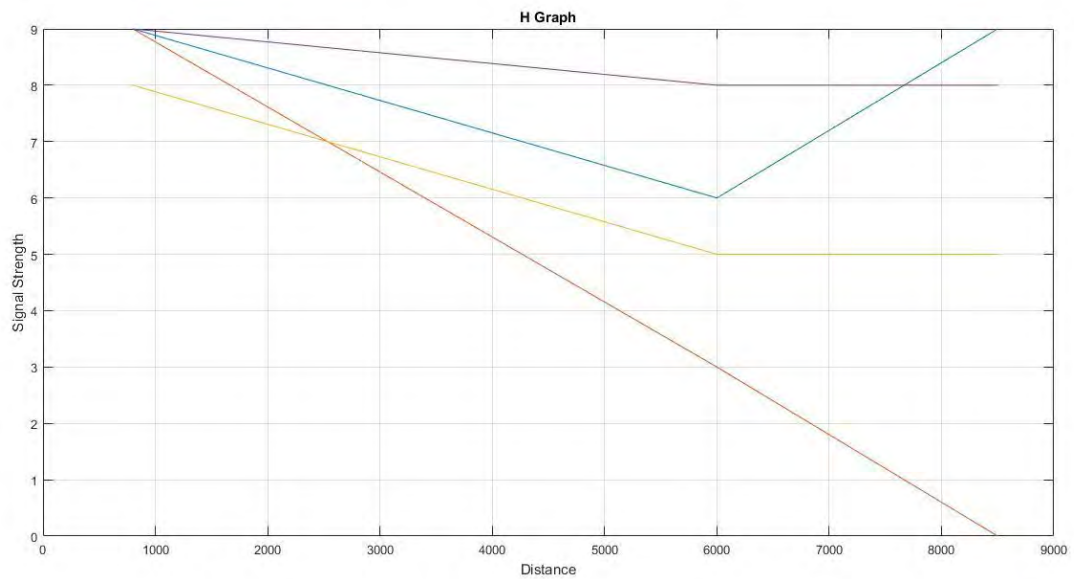

Figure: Distance vs Signal Strength graph in H Mode

# 6 Summary

## 6.1 Conclusion

Nano Satellites have opened a new opportunity for students to study and research in space. As we know, space research is very expensive the Nano-satellite technology has opened up a new window for developing country like ours. BRAC Onnesha Nano Satellite is the first opportunity of this kind in our country.

BRAC Onnesha Nano-satellite ground station is a great platform to study and research in radio communication. It is the frontier for space research in Bangladesh. Its ability to communicate with weather satellite has opened another vast opportunity for the students of different backgrounds. In this thesis, we tried to describe the step by step operation of BRAC Onnesha ground station. This thesis will facilitate the future students to understand the whole system of the ground station and help them in satellite operations.

Also, the analysis of different antennas will give us an over view on different types of antenna that can be used for satellite communication. The portable ground station setup will help to get signals from remote area. From the analysis we can conclude that directional high gain antenna are very effective for satellite communication but during portable remote operation the directional system makes it difficult to operate as we have to rotate the antenna with the satellite position. It is not feasible for portable ground station setup. On the other hand, among these four the lindenblade antenna has performed outstandingly well. Its size and radiation pattern makes it preferable for portable ground station.

## 6.2 Future Work:

In this thesis, we only analyzed Yagi-Uda, QFH, Lindenblad and V-Dipole Antenna. Study on other antenna might bring out some more efficient and effective portable ground station antenna. As this study is more focused on the radiation pattern and polarization further study on these antenna should be done based on gain and materials that are used. To increase the signal strength Low Noise Amplifier (LNA) can be used. Using a low noise amplifier can improve received signal. The antenna were build based on the theoretical length calculation but as an antenna is

subject to change its center frequency based on spacing, material and feed line impedance. It is essential to measure the center frequency after building an antenna. An antenna analyzer can be used to measure the center frequency of the antenna. It is important to find the actual radiation patterns of the antenna that we built. Radiation pattern of an antenna can be measured in an anechoic chamber. Also, the portable ground station setup cost can be minimized by using Raspberry pi micro controller in place of laptop.

## 7 Reference

- [1] PELTON J. N. (2012). *Satellite Communications*. New York, NY: Springer.
- [2] George H. Brown and O. M. Woodward Jr. (1947, June). *RCA Review*, 8(2), pp. 259-269.
- [3] (n.d.). Retrieved November 10, 2016, from <http://www.antenna-theory.com/>
- [4] Gerald Martes. (2008, February). *Double Cross-A NOAA Satellite Downlink Antenna*. Retrieve from <http://www.qsl.net/py4zbx/DCA.pdf>
- [5] (2016, January 25). Retrieved August 18, 2017, from <http://www.teske.net.br/lucas/2016/01/qfh-antenna-and-my-first-reception-of-noaa/>
- [6] (2017, March 1). Retrieved July 15, 2017, from <http://www.rtl-sdr.com/simple-noaameteor-weather-satellite-antenna-137-mhz-v-dipole/>
- [7] Vertex Standard CO. LTD. (1990). *GS232B: User Manual*. Retrieved from [http://gatorradio.org/Manuals/Yaesu\\_GS-232B\\_Manual.pdf](http://gatorradio.org/Manuals/Yaesu_GS-232B_Manual.pdf)
- [8] Vertex Standard CO. LTD. (1990). *Yaesu G-5500: Instruction Manual*. California, MA: Author.
- [9] M2 Antenna Systems, Inc. (2014). *CP42UG Antenna: User Manual*. California, MA: Author.
- [10] M2 Antenna Systems, Inc. (2014). *FGCB60 Crossboom: User Manual*. California, MA: Author.
- [11] Mirage Communication Equipment. (2013). *KP-2/440 Pre Amplifier: Product Manual*. Alabama, MA: Author.
- [12] HRD Software LLC. (2014). *Ham Radio Deluxe: User Guide (6.2)*. Florida, MA: Author.
- [13] (2011, September 8). Retrieved May 29, 2017, from <http://charlietango.co.uk/topic/7515945/1/>
- [14] (2016, May 2). Retrieved April 1, 2017, from [http://micca.at.webry.info/201605/article\\_2.html](http://micca.at.webry.info/201605/article_2.html)
- [15] Marco Mascarello. (2011, November 24). *QFH Antenna for VHF and UHF*. Retrieved from [http://www.aribra.it/autocostruzione/qfh/index\\_e.php](http://www.aribra.it/autocostruzione/qfh/index_e.php)
- [16] R.W. Hollander. (1999-2001). *Resonant Quadrifilar Helix Antenna. Technote (1999-1)*, pp. 18-38.

- [17] Anthony Monterio. (2006). *A Parasitic Lindenblad Antenna for 70cm. AMSAT PROCEEDINGS (2006)*.
- [18] Dr. G. C. Weffenbach. (1974, July 1). *Satellite-Tracking and Earth-Dynamics. Semiannual Progress Report No.31*. Washington, National Aeronautics and space Administration.
- [19] G. Hanley. (1979, March). *Satellite Power Systems (SPS) Concept Definition Study. Final Report (2)*. Alabama, Marshall Space Flight Center.
- [20] Miranda Chin. (1972, March 16). *136 MHz/400 MHz Earth Station Antenna-Noise Temperature Prediction Program, NAS 5-11736*.
- [21] Rainee N. Simons. (n.d.). *Applications of Nano-Satellites and Cube-Satellites in Microwave and RF Domain*.
- [22] *Directive Short Wave Antenna, 1924, IEEE History Center*, New Brunswick. Rutgers University.
- [23] E.E. Altshuler and D.S. Linden. "Design of a Loaded Monopole Having Hemispherical Coverage Using a Genetic Algorithm." *IEEE Trans. on Antennas and Propagation*, Vol. 45, No. 1, January 1997.
- [24] E.E. Altshuler and D.S. Linden. "Wire Antenna Designs using a Genetic Algorithm." *IEEE Antenna & Propagation Society Mag.*, Vol. 39, pp. 33-43, April 1997.
- [25] I.M. Avruch, et al., "A Spectroscopic Search for Protoclusters at High Redshift." *Bulletin of the American Astron. Society*, Vol. 27, No. 4, 1995.
- [26] S. Uda and Y. Mushiake, *Yagi-Uda Antenna*, Maruzden, Tokyo, 1954.
- [27] David M. Pozar. (2012). *Microwave Engineering*. New Jersey. NJ: John Wiley & Sons.
- [28] (n.d.). Retrieved March, 2017, from <https://www.jcoppens.com/ant/qfh/calc.en.php>



## **8 Appendix**

### **8.1 Codes:**

#### **MATLAB**

```
d=[800 6000 8500]
yagi=[9 6 9]
vdipole=[9 3 0]
qfh=[8 5 5]
lindelblad=[9 8 8]

plot(d,yagi)
hold on
plot(d,vdipole)
hold on
plot(d,qfh)
hold on
plot(d,lindelblad)
xlabel('Distance')
ylabel('Signal Strength')
title('H Graph')
```

## 8.2 Additional Images



