

# Portable UV-Spectrophotometer to Determine the Concentration of Potassium

Department of Electrical and Electronic Engineering

A Thesis

Submitted to the Department of Electrical and Electronic Engineering  
of

**BRAC UNIVERSITY**

by

<b>IfranKabir</b>	<b>12121018</b>
<b>Md. TaushikHossain</b>	<b>12121006</b>
<b>Md. Al-Amin</b>	<b>12121015</b>
<b>JahanaraAkterShupta</b>	<b>12121014</b>

**Supervised by**



**Dr. Md. Khalilur Rhaman**

Associate Professor

Department of Computer Science and Engineering  
BRAC University, Dhaka

And



**Dr. Shamshad B. Quraishi**

Chief Scientific Officer

&

Quality Manager

Analytical Chemistry Laboratory

(ISO/IEC 17025:2005 Accredited)

Chemistry Division, Atomic Energy Centre

Bangladesh Atomic Energy Commission

Dhaka-1000, Bangladesh

# Declaration

We do hereby declare that the thesis entitled ‘Portable UV-Spectrophotometer to Determine the Concentration of Potassium’ is submitted to the Department of Electrical and Electronic Engineering of BRAC University in partial fulfillment for the Bachelor of Science in Electrical and Electronics Engineering. This is our original work and was not submitted elsewhere for the award of any other degree or any other publication.

Date: 18.04.2017

## Signature of Supervisor

---

**Dr. Md. Khalilur Rhaman**  
Associate Professor  
Department of Computer Science and  
Engineering  
BRAC University, Dhaka

## Signature of Joint-Supervisor

---

**Dr. Shamshad B. Quraishi**  
Chief Scientific Officer & Quality Manager  
Analytical Chemistry Laboratory  
Atomic Energy Center, Dhaka

## Signature of Authors

---

**IfraKabir | 12121018**

---

**Md. TaushikHossain | 12121006**

---

**Md. Al-Amin | 12121015**

---

**JahanaraAkterShupta | 12121014**

# **Acknowledgement**

We would like to take this opportunity to express our gratitude to Dr. Md. KhalilurRhaman, Associate Professor, Department of Computer Science and Engineering, BRAC university, Dhaka, for his guidance, and instruction that he has given us from time to time throughout our thesis project entitled 'Portable UV-Spectrophotometer to Determine the Concentration of Potassium' under his supervision for the partial fulfillment of our undergraduate program. The skills that we were able to learn from him during our thesis work have benefited us immensely and will continue to do so throughout our future endeavors.

It is also our great pleasure to acknowledge our Joint-Supervisor Dr. Shamshad B. Quraishi, Chief Scientific Officer & Quality Manager, Analytical Chemistry Laboratory (ISO/IEC 17025:2005 Accredited), Chemistry Division, Atomic Energy Centre, Bangladesh Atomic Energy Commission, Dhaka-1000, Bangladesh for her valuable guidance and continuous inspiration during the research period. It is obvious that without her attributed contribution and kind support it would not be possible to complete this research work.

We would like to extend our heartfelt thanks to all of the lab personnel of the Analytical Chemistry Laboratory for their kind cooperation during the research work in the laboratory. We also thank all our peers and every other individual involved with us for being supportive.

# **Abstract**

Bangladesh is mainly depended on agriculture for her economy. Agriculture is the backbone of Bangladesh. Thousands of people depend on agriculture. About 60-70% people depends on agriculture. Agriculture is the main source of our countries economy. It comprises about 15% of the country's GDP and 60% of the total labor force. It is revealed that paddy is the mostly produced crop in this area and fertilizers and pesticides were intensively used for boosting up the production of crops. Fertilizer consumption (% of fertilizer production) in Bangladesh was 314.42 as of 2013. Its highest value over the past 11 years was 440.66 in 2011, while its lowest value was 121.21 in 2002. The problem is that humans tend to use too much of fertilizers in the soil because they have to cater to the global demand of food. To mention more than half of the total yield production is out of synthetic or inorganic fertilizers which contains components like nitrogen, potassium, sulfur, calcium, magnesium, and so on. These chemicals and minerals, although help in boosting the growth of plants, they also have their drastic side effects in the long run. Farmers of Bangladesh use either greater amount or less amount of fertilizer than the standard amount provided by government. Most of the farmers and agrochemical dealers were not aware about the impact of fertilizer and pesticide on crop production and environment as well. This outcome draws base line situation which can be useful towards relevant research. Thus we develop a portable device by which concentration of Potassium (K) in soil can be detected. Farmers will be able to judge what amount of fertilizers to be used for that particular soil thus excessive use of fertilizers can be drastically reduced.

# Table of Contents

TOPIC		PAGE
<b>CHAPTER 1: INTRODUCTION</b>		7
1.1	Objective	7
1.2	Background Information	7
1.3	Importance of Agriculture in Our Country	8
1.4	Use of Fertilizer in Our Country	9
1.5	Adverse Effect of Fertilizer	10
1.6	Literature Review	11
<b>CHAPTER 2: Techniques for Measuring Potassium</b>		12
2.1	Flame Photometry	12
2.2	Atomic Absorption Spectroscopy	15
2.3	UV-Spectroscopy	17
<b>CHAPTER 3: Importance of Potassium for Plant Growth</b>		26
3.1	Macronutrients and Micronutrients	26
3.2	Reasons for choosing Potassium	28
3.3	Soil Collection Procedure	31
3.4	Potassium Extraction Method from Soil	32
3.5	Preparation of Potassium Stock Solution	33

<b>CHAPTER 4: Circuit Analysis</b>		34
4.1	UV Sensor(UVM-30A)	34
4.2	Arduino Uno	35
4.3	LiPo Battery	37
4.4	LM2596 Buck Converter	39
4.5	Liquid Crystal Display	43
<b>CHAPTER 5: Data Analysis</b>		45
<b>CHAPTER 6: Reference</b>		48
<b>CHAPTER 7: Appendix</b>		49

# Chapter - 1

## Introduction

### 1.1 Objective

As we all know Bangladesh is an agro based country where most of the people's main income source is agriculture. Farmers use fertilizer to increase productivity of their crops. Most of them use fertilizer without knowing how much they really need. As a result a huge amount of money has been wasted. On the other hand using excessive amount of fertilizer has further effect on soil and environment. The main purpose of this thesis is to build such a device which will analyze the amount of component available in soil and tell the user what amount of fertilizer they should use for better productivity.

Soil components can be divided into two types, they are macro and micro. Nitrogen (N), Phosphorus (P), Potassium (K), Calcium (Ca), Sulfur (S), Magnesium (Mg) are macro components and Boron (B), Chlorine (Cl), Manganese (Mn), Iron (Fe), Zinc (Zn), Copper (Cu), Molybdenum (Mo), Nickel (Ni) are micro components of soil. This two types are vital for plant nutrition . Two types of techniques are basically used to measure those components, they are Spectroscopy and Electro chemical sensing respectively. As our goal is to build a portable devise for measuring amount of components, so we choose UV spectroscopy technique here. UV spectroscopy is the measuring system of the attenuation of a beam of light after it passes through a sample or after reflection from a sample surface. Absorption measurements can be at a single wavelength or over an extended spectral range. Considering cost efficiency and portability we found UV spectroscopy techniques is the best for our portable device. Most of the equipment's were collected from local market.

As soil contains a huge amount of components so it is quite impossible for a cost When UV light wave pass through the sample a radiation will occur because electron will be promoted to higher state from lower state and a detector will measure this energy change and convert this into voltage. The voltage we will receive will be the measuring parameter of soil components. effective portable device to measure each components. So, we choose to measure the amount of Potassium (K) available in soil. Potassium is one of the vital macro components for plant and large amount of Potassium based fertilizer are used by farmers in our country and this are the reason behind choosing Potassium as our sample object.

### 1.2 Background Information

In the 1930s, vitamin look into demonstrated that few vitamins Ultra violet (UV) light. Impelled by the American government's enthusiasm for measuring vitamin content in soldiers proportions utilizing UV light, this examination finished in the business dispatch of UV-Vis

spectrophotometers in the mid-1940s. Of these, the Beckman DU spectrophotometer—first sold in 1941—separated itself from contending items by conveying more exact outcomes and lessening examination time from hours, or even weeks, to minutes.

Albeit cutting edge UV-Vis spectrometers vary significantly from the primary DUs, all work on a similar essential rule. Light is measured from UV-Vis source lights prior and then afterward the light goes through a specimen. The measure of light retained compares to the sub-atomic focus in the specimen.

Whether as standalone instruments or high performance liquid chromatography (HPLC) identifiers, UV-Vis spectrophotometers are vital for measuring investigative fixations—in logical research, academic education, and QA/QC labs considering pharmaceuticals, proteins, DNA, solar panel , semiconductors, and coatings. New instrument plans and frill have extended the scope of UV-Vis tests—from fluids generally measured in milliliter volumes in 1-cm cuvettes to today's micro scale volume.

Nobel laureate Bruce Merrifield alluded to the UV-Vis spectrophotometer as “probably the most important instrument ever developed toward the advancement of bioscience.”

### **1.3 Importance of Agriculture in Our Country**

Bangladesh is mainly relied on agro business for her economy. Farming is the backbone of this country. A large number of people rely on agriculture. Around 60-70% individuals depends on farming. Agriculture is the primary wellspring of our nation’s economy. It includes around 15% of the nation's GDP and 60% of the aggregate work drive.

About one third of annul income comes from agriculture and the total annual exports items of 15% are mainly agriculture product. So, we totally depend on this sector.

Farming is one of the main occupations of our country's people and it is one of the oldest professions of this country's people. Around 70% people directly or indirectly depends on agriculture as their professions. If this sector develop then the whole industrial and economic development is possible.



## 1.4 Use of Fertilizer in Our Country

A fertilizer is any material of natural or synthetic origin that is applied to plant tissues basically on leaves or to soil to supply one or more plant nutrients essential to the growth of plants.

For a plant in order to grow and thrive, it needs different types of chemical elements.

**Nitrogen, phosphorus and potassium** are the most important of these.

If any of the macronutrients are missing from the soil, this will limit the growth rate of plant. Naturally nitrogen, phosphorous and potassium often come from the decay of plants that have died. Nitrogen is recycled from dead to living plants which is often the only source of nitrogen in the soil.

To make plants grow faster, what we need to do is supply the elements that the plants need in readily available forms. The goal of fertilizer is to supply this elements. When we use fertilizers mostly we supply nitrogen, phosphorus and potassium because the other chemicals are needed in much lower quantities and are generally available in most soils. Nitrogen, phosphorus and potassium availability is the big limit to growth.

In Bangladesh farmers are aware of importance of using fertilizer but they have lack of information or knowledge about the amount they should use or which types of fertilizer they should apply in their land, without knowing the proper amount or necessary amount they use it randomly. As a result, this excessive use causes them a huge waste of money. On the other hand random use of fertilizer has noxious effect on environment too. So a device is urgent to build that will give direction to the root level farmer about the amount of fertilizer they should use for cultivation.

According to World Bank and Index Mundi Fertilizer, consumption (kilograms per hectare of arable land) in Bangladesh was 208.66 as of 2013. Its highest value over the past 11 years was 278.83 in 2012, while its lowest value was 160.27 in 2003.

A statistics of fertilizer consumption in recent years has been given bellow

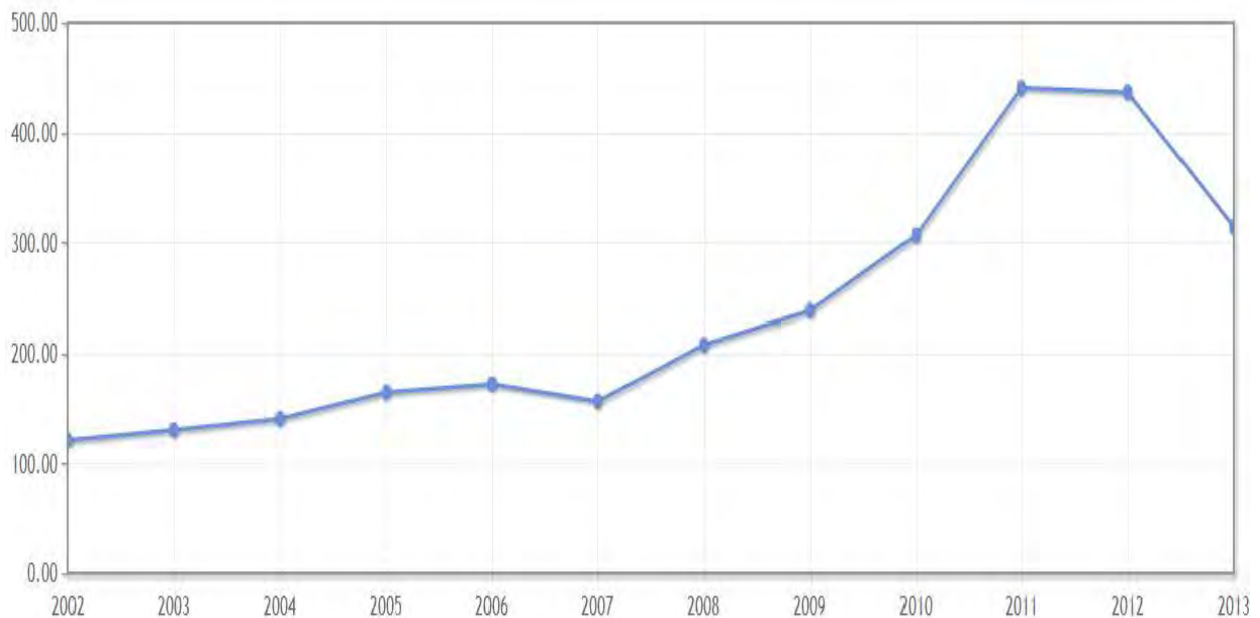

From the above graph it becomes clear that uses of fertilizer is increasing rapidly and situation is going to an alarming position.

## **1.5 Adverse Effect of Fertilizer**

According to the Environmental Protection Agency, most fertilizers contain about the same basic materials: potassium, nitrogen, phosphorus and sometimes other nutrients, like zinc, needed for healthy plant growth. Fertilizers are used to give extra life of land fertility, but less people consider the adverse effect of these fertilizers. It is important to consider the potentially noxious effects of fertilizers as well as the benefits.

### **1.5.1 Human Carcinogens**

The most critical destructive impacts originate from compost that is intended to kill or avert weeds. According to the EPA's Office of Pesticide Programs, 12 of the most popular pesticides in the United States have ingredients known to cause cancer. Natural composts are ensured to be alright for the earth, the body and free of pesticides.

### **1.5.2 Water Pollution**

While composts might be useful to the plants, they are not generally as sound for the rest of the environment. A considerable lot of the "quick-release" composts have been known to prompt to oxygen loss in waterways due to runoff into the street and, as a result, into the water. High amounts of nitrogen can find their way into waterways in this way, causing an excess of algae and a resulting loss of oxygen in the water. This can negatively affect fish and other natural life in the water.

### **1.5.3 Toxic Waste Potential**

Many individuals don't understand that lots of fertilizers are produced using the residuals of waste water treatment plant or reused from different regions that make them test positive for toxic waste. As indicated by the federation of Public Interest Research Groups (PIRG), 29 popular fertilizers tested positive for 22 toxic heavy metals, including silver, nickel, selenium, thallium and vanadium. The greater part of the metals found is connected straightforwardly to human wellbeing risks.

## **1.6 Literature Review**

To understand what should be the best way to design a device that will sense and measure the amount of components are in soil we had studied plenty of journals and books. To do our thesis work, firstly we briefly studied about soil. Here we took help from some journals published in ANALYTICA CHIMICA ACTA. Besides taking information from journals we collected some books for a sound knowledge about soils character and fertilizers impact on soil. “Soil Fertility and Fertilizers: An Introduction to Nutrient Management ” by John L. Havlin, Samuel L. Tisdale, Werner L. Nelson, James D. Beaton was one of the finest among those books. It give us a deep knowledge about soil, its character and types of fertilizer that should be used most to make soil more fertile.

After acquiring knowledge about soil we had searched to find a way that will guide us to design our own device. Before designing our device we learned what would be the best technique to measuring components in soil. “Basic Principles of Spectroscopy” by R. Chang was our guideline for this purpose. Here we learned about spectroscopy method and its basic principle. By going through this book we had learned about UV-VIS spectrophotometer and found that this technique is perfect for making a portable device.

To analyze soil through UV-VIS spectrophotometer it is compulsory to make a soil solution which will respond when light pass through this solution. To make sample soil compatible for this test we have collected plenty of journals.

# **Chapter 2**

## **Techniques for Measuring**

### **Potassium**

#### **2.1 Flame Photometry**

Flame photometry is the process where through emission of radiation by neutral atoms, concentration is determined. The name flame photometry comes from the use of flame to acquire neutral atoms from the sample.

##### **2.1.1 Flame Photometer Working Principal**

When a solution of metallic salt is being showered as fine droplets into the flame, due to the heat of the flame, the drops dry leaving a fine residue of the salt. This fine residue transforms into neutral atoms.

Through the procedure of coming back to ground state, the energized atoms discharge a radiation of particular wavelength. For every element, the wavelength of radiation is particular.

This peculiarity of the wavelength of light discharged makes it a subjective component. While the intensity of radiation relies on upon the concentration of component, this makes it a quantitative trademark.

Despite the fact that this procedure is straightforward and is appropriate to all elements, but practically, only a few elements of Group 1A and Group 2A (like Na, K, Li, Ca & Mg) are only analyzed. The radiation emitted in the process is of specific wavelength. Like, for Sodium (Na) 589nm yellow radiation, Potassium 767nm range radiation.

##### **2.1.2 Flame Photometer Instrumentation**

1. Burner
2. Monochromators
3. Detectors
4. Recorder and display.

**Burner:** Burner is the part where atoms are made excited by showering the sample solution into an oxidant and fuel combination. A homogenous flame of stable intensity is produced.

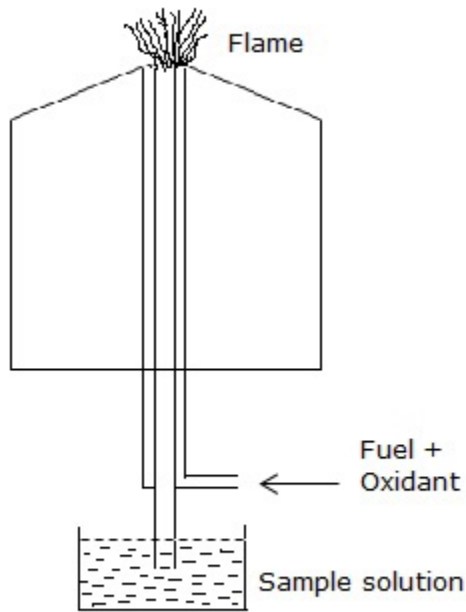

**Total Consumption Burner**

There are different types of burners like Total consumption burner, Laminar flow and Mecker burner.

**Fuel and oxidants:** Fuel and oxidant are expected to make flame so that the sample changes to neutral atoms and get energized by the heat energy. The temperature of flame needs to be stable and also ideal. If the temperature is very high, then instead of neutral atoms, the elements in the sample change into the ions. If the temperature is too low, atoms may not reach its excited state. As a result, the combination of fuel and oxidants needs to be used in such a way that the heat can be raised to the required temperature.

The following combination of fuel and oxidants are commonly used:

Fuel	Oxidant	Temperature of Flame
Propane +	Air	2100 Degree C
Propane +	Oxygen	2800 Degree C
Hydrogen +	Air	1900 Degree C
Hydrogen +	Oxygen	2800 Degree C
Acetylene +	Air	2200 Degree C
Acetylene +	Oxygen	3000 Degree C

**Monochromators:** Filters and monochromators are required to isolate the light of specific wavelength from the remaining light of the flame. For this, simple filters are required as we study only few elements like Ca, Na, K and Li. So a filter wheel with filter for each element is taken. When a specific element is analyzed, that specific filter is with the goal that it filters rest of the wavelengths.

**Detector:** Flame photometric detector is very similar to that used in spectrophotometry. The emitted radiation is in the visible region i.e. 400nm to 700nm. Furthermore, the radiation is fixed for each element, so the simple detectors are enough for this purpose, like photo voltaic cells, photo tubes etc.

**Recorders and display:** These are the devices to read out the recording from detectors.

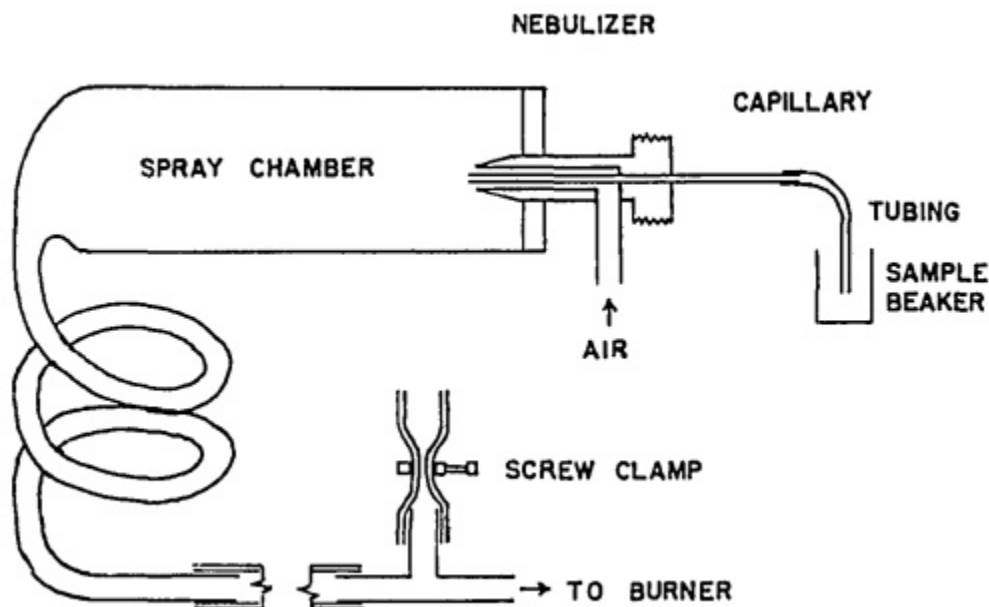

### **2.1.3 Flame Photometer Applications:**

1. For qualitative analysis of samples by contrasting the standard value to that of the spectrum emission wavelengths.
2. For quantitative analysis of group 1A and 2A components to find their concentration. For instance
  - a) Concentration of calcium in hard water.
  - b) Concentration of Sodium in Urine.

### **2.1.4 Flame photometry limitations:**

Unlike other spectroscopy methods, flame photometry is not much used in research and analysis. This is due to:

1. Very small number of elements that can be analyzed.
2. The sample needs to be presented as solution into fine droplets. Most of the metallic salts, plant, soil and others are not soluble in such common solvents. As a result, they can't be analyzed by this method.
3. As the sample is volatilized, since some of the sample gets used up due to vaporization, it is very unsafe to analyze by this method if a small amount of sample is present.
4. Furthermore during solubility with solvents, other impurities might get mixed up with sample and that may lead to errors in the result achieved.

## **2.2 Atomic Absorption Spectroscopy:**

Atomic absorption spectroscopy is a type of quantitative analysis where in a specific wave length of light absorbed by atoms in neutral state is detected.

The more the number of the atoms, the more is the intensity of absorption and vice-versa.

This can also be called as [metal](#) analysis spectrometer as it is mainly used for metal analysis.

### **2.2.1 Atomic Absorption Spectroscopy Theory**

The method involves the spraying of sample in solution state over a burner. This leads to evaporation of solvent and leave fine dry residue behind which is nothing but neutral atoms in ground state. To these atoms, a light of specific wave length is passed and the un-absorbed light is recorded over a detector.

### 2.2.2 Atomic Absorption Spectroscopy Instrumentation

Unlike other spectroscopy methods, atomic absorption spectroscopy needs to have two additional requirements to work. They need to have a specifically designed lamp to produce the light of the desired wave and a burner to make the sample prepared for the absorption of light.

The instrumentation includes:

1. The burner to dry the sample and produce atoms.
2. Sample container.
3. Fuel and oxidant to burn the sample by heat.
4. Hollow cathode lamp to produce light of desired wave length.
5. Detector to detect the absorption intensity.
6. Amplifier and data recorder.

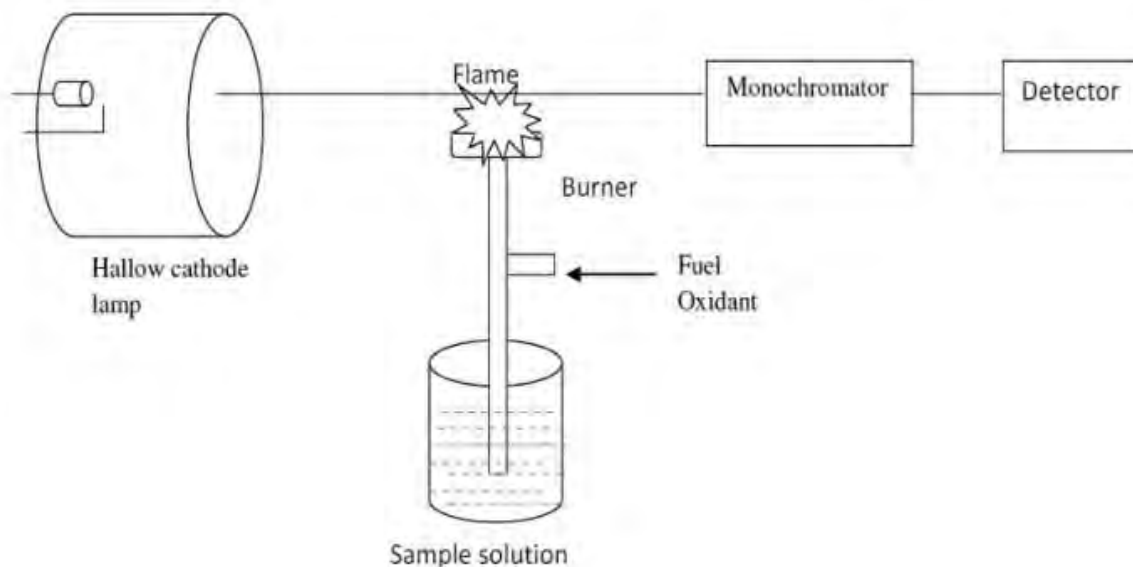

**The burner:** From the burner, sample from the capillary rises to the top of burner where it is burned with flame made by the combination of fuel and oxidant. After evaporation, the sample leaves a fine residue of neutral atoms.

**Sample container:** This container is like a beaker container of sample that is placed preferably below the burner. A capillary tube drains the sample to the tip of burner.



**Fuel and oxidant:** This is a primary requirement to be remembered of entire process. If the temperature rise is not sufficient enough, then the sample doesn't form neutral atoms. If the temperature of burner is more than expected, instead of forming atoms, the sample molecules may ionize. Both of the conditions are undesirable for experimentation. So, a correct combination of fuels and oxidant are required to be used to produce the recommended temperatures. Commonly used fuels include propane, acetylene and hydrogen and oxidants mostly used are air or oxygen.

**Hallow cathode lamp:** This is another very key part in the entire process of atomic absorption. If the element here analyzed to be is calcium, the cathode lamp made of calcium is being used and that is the process for all the other metals, like Na, Mg, K, Zn etc.

**Detector:** The voltage or current recorded for the sample absorption is recorded in a [software](#), which is then analyzed as required.

### **2.2.3 Atomic Absorption Spectroscopy Instrumentation**

1. Atomic spectroscopy is used for quantitative analysis of metal elements in any sample.
2. It is especially useful to analyze trace metal elements in plasma and other body fluids.
3. To determine metal elements in food industry.
4. To estimate Lead in petroleum products.

## **2.3UV Spectroscopy:**

UV spectroscopy is an important tool in analytical chemistry. The other name of UV (Ultra-Violet) spectroscopy is Electronic spectroscopy as it involves the promotion of the electrons from the ground state to the higher energy or excited state. In this article I will explain the basic principle, working and all the applications of UV spectroscopy.

Introduction to UV spectroscopy:

UV spectroscopy is type of absorption spectroscopy in which light of ultra-violet region (200-400 nm.) is absorbed by the molecule. Absorption of the ultra-violet radiations results in the excitation of the electrons from the ground state to higher energy state. The energy of the ultra-violet radiation that are absorbed is equal to the energy difference between the ground state and higher energy states ( $\Delta E = hf$ ).

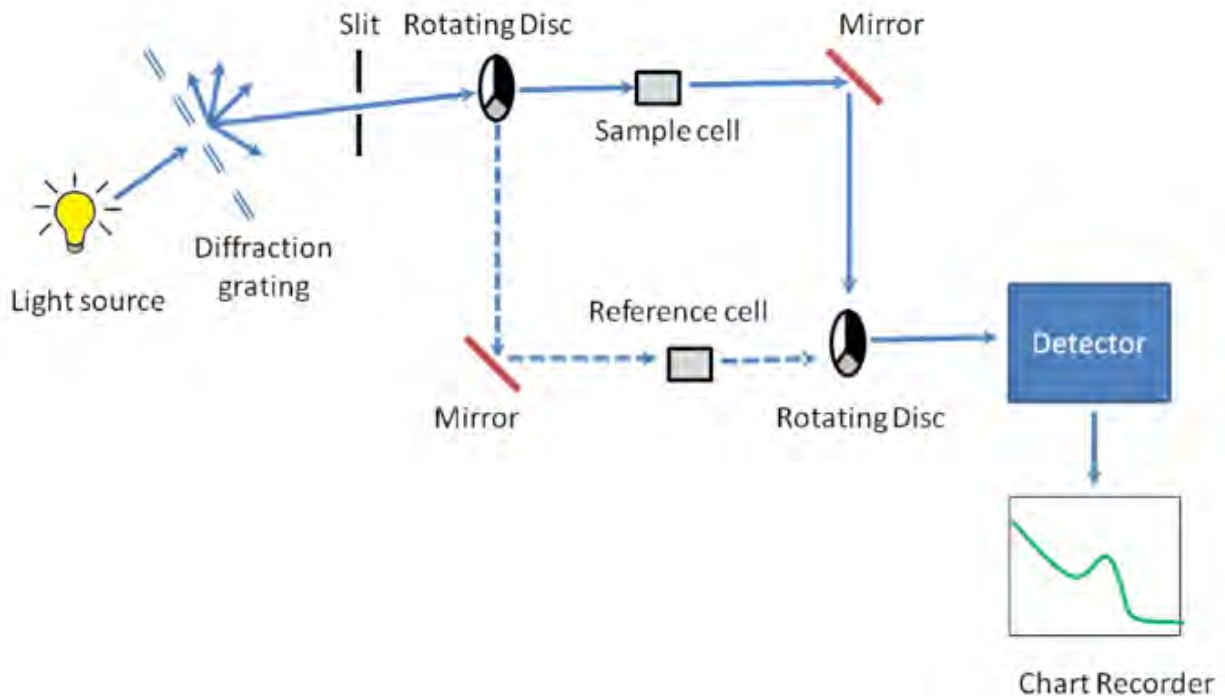

### 2.3.1 Principle of UV spectroscopy

UV spectroscopy complies with the Beer-Lambert law, which expresses that: when an emission of monochromatic light is passed through a solution of an absorbing substance, the rate of force of radiation with thickness of the absorbing solution is proportional to the incident radiation as well as the concentration of the solution.

The expression of Beer-Lambert law is-

$$A = \log (I_0/I) = Ecl$$

Where, A = absorbance

$I_0$  = intensity of light incident upon sample cell

I = intensity of light leaving sample cell

C = molar concentration of solute

L = length of sample cell (cm.)

E = molar absorptivity

From the Beer-Lambert law, it is obvious the quantity of particles equipped for retaining light of a given wavelength, the higher the degree of light absorption. This is the basic principle of UV spectroscopy.

### **2.3.2 Applications of UV spectroscopy:**

1. Detection of functional groups- UV spectroscopy is utilized to recognize the presence or absence of chromophore in the compound. This method is not valuable for the location of chromophore in complex compounds. The absence of a band at a specific band can be viewed as an evidence for the nonappearance of a specific group. On the off chance that the range of a compound turns out to be straightforward over 200 nm, then it confirms the absence of –  
a) Conjugation b) A carbonyl group c) Benzene or aromatic compound d) Bromo or iodo atoms.

2. Detection of extent of conjugation- The degree of conjugation in the polyenes can be distinguished with the help of UV spectroscopy. With the expansion in double bonds, the ingestion shifts towards the longer wavelength. If the double bond is increased by 8 in the polyenes then that seems unmistakable to the human eye as the assimilation comes in the visible region.

3. Identification of an unknown compound- An unknown compound can be identified with the help of UV spectroscopy. The spectrum of unknown compound is compared with the spectrum of a reference compound and if both the spectrums coincide then it confirms the identification of the unknown substance.

4. Determination of configurations of geometrical isomers- It is observed that cis-alkenes absorb at different wavelength than the trans-alkenes. The two isomers can be distinguished with each other when one of the isomers has non-coplanar structure due to steric hindrances. The cis-isomer suffers distortion and absorbs at lower wavelength as compared to trans-isomer.

5. Determination of the purity of a substance- Purity of a substance can also be determined with the help of UV spectroscopy. The absorption of the sample solution is compared with the absorption of the reference solution. The intensity of the absorption can be used for the relative calculation of the purity of the sample substance.

### **2.3.3 Basic Concept of Ultraviolet Spectrophotometer:**

Spectrophotometers are kind of device which mainly sends electromagnetic radiation into a position and after that it decide the subsequent association of the vitality and the position. The UV Spectrophotometer make some effect to the retention of bright light in view of an electron which bounce starting with one position then onto the next energized position. To assimilates or conveys certain wavelengths spectrophotometer really makes a difference. Electron excitation starting with one vitality level then onto the next energized vitality level is the reason of the assimilation of vitality. At that point it manages the piece of the electromagnetic radiation which is utilized as a part of these machines. The light vitality assimilated or transmitted must match precisely. The vitality required to bring about an electronic in the substance circumstance. Hence, it is settled for particular wavelengths to retain or transmit for a specific substance.

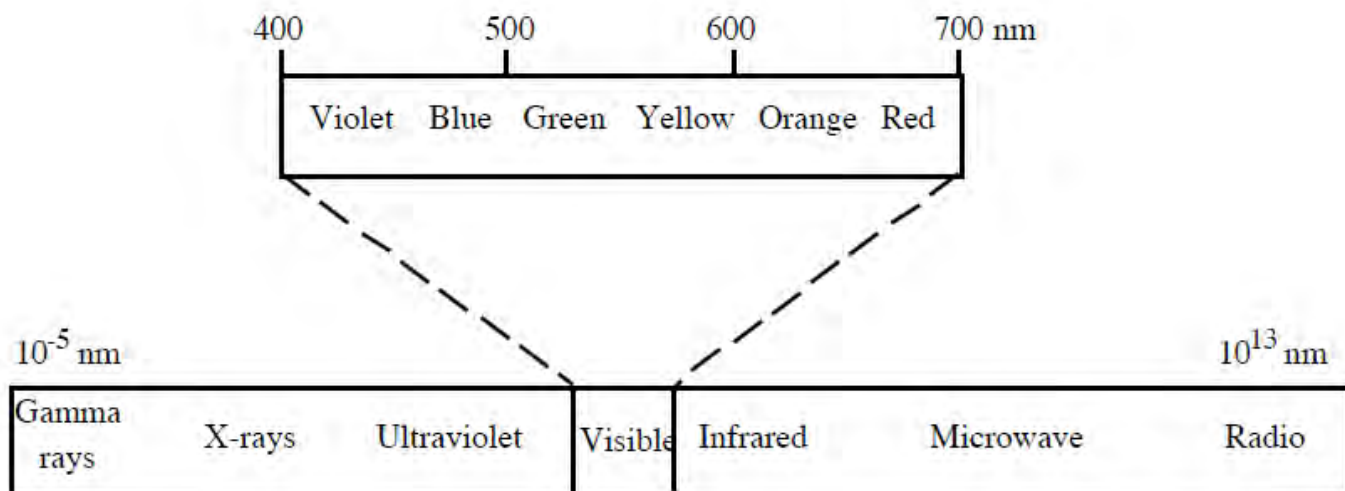

**Figure: The way a Spectrophotometer works.**

**Wavelength Range:** The UV run extends from 100-400nm, where ordinary bright range shifts from 100-900nm. The known range is 190-400nm for close bright. Then again, obvious range fluctuates from 400-900nm. Every shading has their particular known wavelength. So when we need to discover the wavelengths of any molecule, we get those particular wavelengths for particular shading.

Beneath the wavelengths for various colors are appeared where we can see the shading we watch and the shading gets ingested is not comparative. Additionally extraordinary hues have their diverse wavelengths.

**Color Observed Color Absorbed Wavelength**

Red	Bluish green	800
Orange	Greenish blue	650
Yellow	Blue	560
Green	Purple	495
Blue	Yellow	435
Violet	Yellow-green	400

The colors which we observe in visible spectrum and their wavelengths are given below-

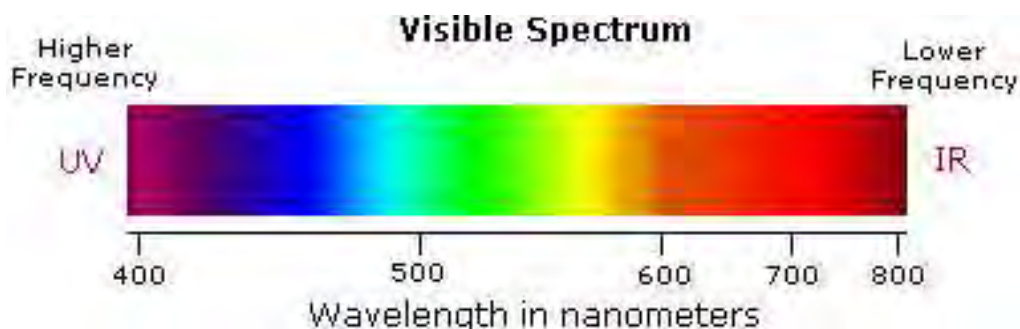
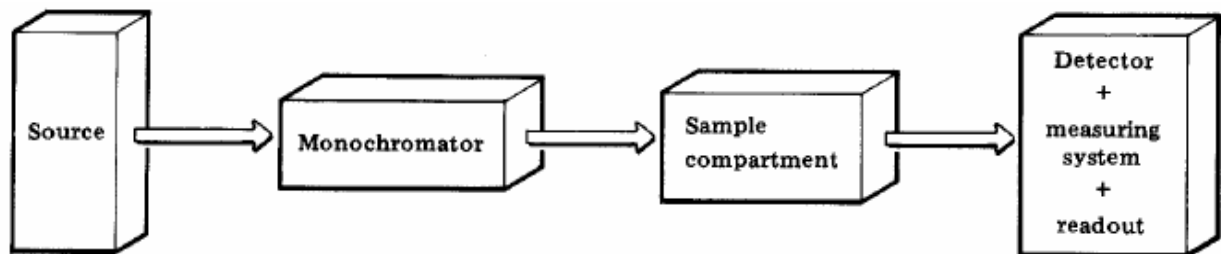

**Figure: Wavelengths of different colors.**

### 2.3.4 Construction of UV Spectrophotometer:

The fundamental chart of an UV Spectrophotometer is demonstrated as follows. A spectrophotometer can be utilized to recognize mixes by getting the entire structure of wavelengths consumed by a given example. The convergence of engrossing mixes in that example is relative to the measure of light ingested. Soto get the concentration of compounds in solution, a spectrophotometer can be used.

The equipments of spectrophotometer is given below-



**Figure: Construction of UV spectrophotometer.**

**Source Objective:** One of the critical parts of spectrophotometer is source. At the season of measuring, it ought to be totally steady. The power of transmitted radiation ought not move from here to there at the season of estimation. Over an extensive region there ought to be sufficient force. A security of silica is essential for warmth era and furthermore for transmission of shorter wavelength. The constraining component is typically 190 nm for lower breaking point of climatic transmission.

There are two sorts of light for any source. One of them is Tungsten and the other is Tungsten-halogen. Already a tungsten light was utilized for obvious light. In any case, today rather than it a tungsten-incandescent light is utilized. Since it has higher yield in the area from 320nm to 380

nm. To keep up straightforward modification systems for simple substitution, lights are essentially utilized. As of late, another light named Xenon light has likewise been acquainted with enhance the capacity.

**Source range:**Ultraviolet light mainly provides 190 - 380 nm range for emission of high intensity and enough continuity.

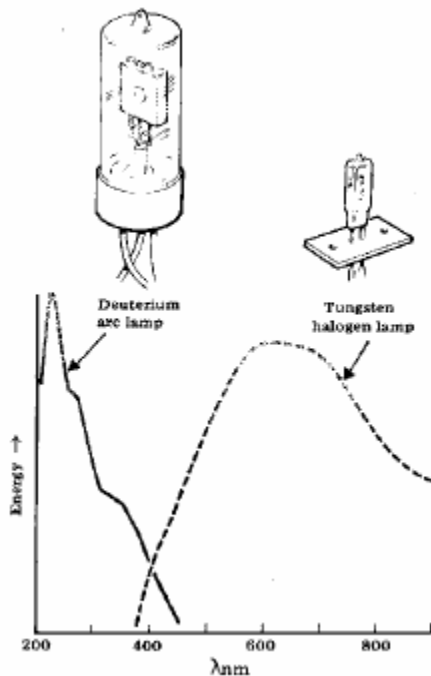

**Figure: Different sources and their wavelengths.**

**Monochromator:**Monochromator is another important part of UV Spectrophotometer. Creating a beam of single wavelength is the main working factor of a monochromator. A beam of single wavelength is the radiation which is found from a long range of wavelengths. The monochromator makes a dispersive element, an entrance slit and mirrors to create a parallel beam. Which helps the sunlight and exit slit with mirrors to extract the monochromatic light. It should be measured very perfectly.

Necessary equipments which are needed to make a monochromator-

- 1.An exit slit.
2. Collimating device.
3. Entrance slit.
4. A mirror or focusing lens and
5. A wavelength selection or dispersing system exit slit.

**Prism:** Prism is a transparent product which works like an optical element. It has flat and polished surfaces which helps to reflect light. In between two surfaces, there must be an angel. The angel depends on the application provided on the prism. In the Ultra Violet area, it has higher spread. Prism works as breaking the lights into its constituent wavelength which is known as dispersion. A perfect prism with perfect material will give a continuous spectrum in which the component wavelengths are separated in space. For a prism, it is a very important task. Prism can be useful for reflecting lights or splitting lights into components with different polarizations. It is important to make a good definition of the light between the source and the prism where an entrance slit and a collimator are used to complete the task. Light changes speed as it moves from one place to another. After dispersion the spectrum stays at the exit slit and it may be scanned across the beam which actually helps to isolate the needed wavelength. In practically prism rotates to make the spectrum to move across the exit slit.

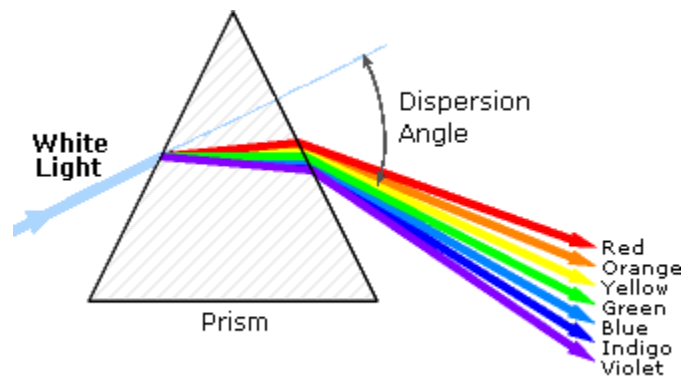

**Figure:Prism.**

Prism monochromators having bandwidths of 1 nm can be achieved easily. So comparing with other filter-based designs, performance should be greatly improved.

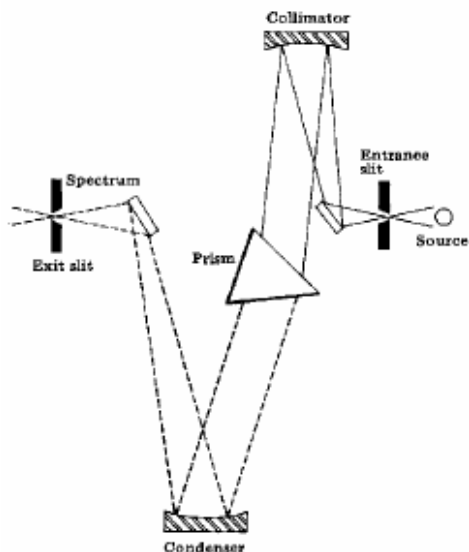

**Figure: Prism monochromator.**

Some lacking of prisms:

Prism is very useful in many ways. Instead of having many benefits, there is also some lacking on prisms which are given below-

1. They have dispersion which is non-linear.
2. The temperature related with features of the commonly used prism materials and
3. The complicated prisms drive mechanism which is necessary to provide a proper wavelength control.

**Filters:** Filters of different colored glasses are very easy to find out. But those glasses are very much limited because of their limitation to the visible region. On the other hand, they have wide spectral bandwidths. The bandwidths are found better than 30 - 40 nm. Interference filters, necessarily a substrate on which materials of unlike refractive indices have been deposited can be made with bandwidths of 10 nm.

### **2.3.5 Spectrophotometer Usage of UV:**

Today the spectrophotometer has become very popular because of many useful uses of it. To eradicate many industrial and clinical problems it can be used. It basically defines the amount of any molecule or particle that reacts to form a colored product. Specially, in most laboratories ultraviolet and visible spectrophotometer is used. Nowadays It is concerned with the identification and measurement of organic and inorganic compounds in a wide range of products and processes in foods, nucleic acids, proteins, pharmaceuticals and fertilizers, in mineral oils and also in plant.



### **2.3.6 Different Spectrophotometer:**

There are some different kinds of spectrophotometer. Because of their single beam, split beam or double beam types, they are different. Those are also used for different purposes. These types of instruments need the following material for their constructions:

#### **Split Beam:**

The Split beam is UV-Vis Spectroscopy which needs a particular beam of light separated into reference. They use a separate detector for each. Split beam instruments have reference detector inside the instrument optics. It offers the advantage of optical stability like in double beam spectroscopy while using the single beam procedure.

#### **Double Beam:**

Double beam is another UV-Vis spectroscopy which needs two beams of light. Both of them should have same intensity to find the absorbance through sample and reference positions. For analytical measurement, sample position is used and method is used.

# Chapter 3

## Important Elements for Plant Growth

### 3.1 Macronutrients and Micronutrients

---

Plant concentrations of important elements may exceed the **critical concentrations**, the minimum concentrations required for growth, and may vary from species to species. The following table gives the general requirements of plants:

Element	Symbol	mg/kg	percent	Relative number of atoms
Nitrogen	N	15,000	1.5	1,000,000
Potassium	K	10,000	1.0	250,000
Calcium	Ca	5,000	0.5	125,000
Magnesium	Mg	2,000	0.2	80,000
Phosphorus	P	2,000	0.2	60,000
Sulfur	S	1,000	0.1	30,000
Chlorine	Cl	100	--	3,000
Iron	Fe	100	--	2,000
Boron	B	20	--	2,000
Manganese	Mn	50	--	1,000
Zinc	Zn	20	--	300
Copper	Cu	6	--	100
Molybdenum	Mo	0.1	--	1
Nickel	Ni	0.1	--	1

Arbitrarily, a dividing line is drawn between those nutrients required in greater quantities, **macronutrients**, and those elements required in smaller quantities, **micronutrients**. This division does not imply that one nutrient element is more imperative than another, simply that they are required in various amounts and concentrations. On the table above, the separating line is regularly drawn amongst S and Cl, implying that:

Macronutrients: **N, K, Ca, Mg, P**, and **S**, and

Micronutrients: **Cl, Fe, B, Mn, Zn, Cu, Mo**, and **Ni**

### **3.1.1 Primary and Secondary Nutrients**

Every single basic component are by definition required for plant development and fulfillment of the vegetation cycle from seed to seed. Some fundamental components are required in substantial amounts and others in considerably littler amounts. However, from a practical standpoint, three of the six essential macronutrients are most often "managed" by the addition of fertilizers to soils, while the others are most often found in sufficient quantities in most soils and no soil amendments are required to supply adequate supplies.

From a management point of view just, the essential nutrients are N, P, and K, since they are frequently constraining from a yield generation angle. The greater part of the other basic macronutrient components are auxiliary or secondary nutrients since they are once in a while constraining, and all the more once in a while added to soils as fertilizers.

The capacity of soils to supply secondary nutrients to plants inconclusively is liable to the law of conservation of matter and is along these lines subordinate upon nutrient cycling. Proceeded with yield expulsion of Ca, Mg, and S requires replenishment similarly as without a doubt as primary nutrients, yet in all probability less as often as possible. Calcium and magnesium are regularly provided by mineral weathering, both of normal soil materials or of aglime, ground limestone added to minimize soil acidity. Sulfur is regularly added to soil as either environmental deposition (related with air contamination) or as pollutions in composts/fertilizers, especially basic P manures/fertilizers.

To demonstrate that this classification is more responsive to soil ability to supply nutrients than plant requirements, it should be noted that plant requirements for Ca, a secondary nutrient element, is greater than for P. Calcium is found as a standard replaceable cation in many soils and a vital solvent soluble cation in the solution of the soil. Phosphorus, then again, is just somewhat dissolvable in many soils, and many soils (especially acidic soils and basic soils) have the potential for creating phosphorus inadequacies.

Whether a macronutrient or micronutrient, or whether a primary or secondary nutrient, the Law of the minimum holds: the most growth-limiting nutrient will limit growth, no matter how favorable the nutrient supply of other elements. For instance, an insufficiency of Fe or Mn (most available in soils containing calcium carbonate) can extremely constrain plant development inspite presence of satisfactory amounts of N, P, and K.

## **3.2 Reasons For Choosing Potassium**

Potassium is an important plant nutrient and is needed in huge amounts for proper growth and reproduction of plants. Potassium is considered second most important only to nitrogen, when it comes to nutrients needed by plants, and is commonly considered as the “**Quality nutrient.**”

It affects the plant shape, size, color, taste and other measurements related to healthy produce. Plants absorb potassium in its ionic form,  $K^+$ .

### **3.2.1 Roles of Potassium in Plants**

Potassium has different kind of roles in plants:

- In Photosynthesis, potassium controls the opening and shutting of stomata, and in this manner controls carbon di oxide consumption. Potassium triggers initiation of enzymes and is important for creation of Adenosine Triphosphate (ATP).
  - Potassium plays a vital role in the regulation of water in plants (osmo-regulation). Both intake of water via plant roots and its loss through the stomata are affected by potassium.
  - Potassium is known to improve drought resistance. Potassium is also required in protein and starch production in plants. Potassium is important at almost every step of the protein production. In starch production, the enzyme responsible for the process is activated by potassium.
- Activation of enzymes – potassium has an important role in the activation of many growth related enzymes in plants.

**Pottasium deficiency symptoms:**



**Potassium deficiency  
in banana**



**Potassium deficiency  
in citrus**



**Potassium deficiency  
in potato**

**Chlorosis –** One of the first symptoms of Potassium deficiency is scorching of plant leaves, with yellowing of the margins of the leaf. Symptoms appear on middle and lower leaves.

**Slow or Stunted development** – as potassium is an imperative development catalyst in plants, plants without potassium will have slower or hindered development.

**Powerless resistance to temperature changes and to dry season** – Poor potassium uptake will bring about less water dissemination in the plant. This will make the plant more helpless against dry season and temperature changes.

**Defoliation** - Lack of potassium in plants brings about plants losing their leaves sooner than they ought to. This procedure may turn out to be much quicker if the plant is presented to dry season or high temperatures. Leaves turn yellow, then darker and in the end tumble off one by one.

Other symptoms of Potassium deficiency:

- 1) Poor resistance to pests
- 2) Weak and unhealthy roots
- 3) Uneven ripening of fruits

Proper usage of fertilizer can avoid potassium deficiencies and damage to crops.

### **3.2.2 Potassium Fertilizers**

**Potassium Chloride, (KCl):** Most of the time it is mined as sylvite ore (KCl, which is the potassium analog of rock salt, NaCl) mixed with NaCl, helped to remove some of the contaminants, and sold. These products are often red because of contaminants which, although not water-soluble but are not harmful for soil application. Crystallization from brine also creates KCl, either from solution mining of KCl ore or precipitation from hypersaline lakes (e.g., Dead Sea), often with carnallite  $KClMgCl_2$  as an intermediate precipitate. The final form of KCl from crystallization processes is white crystals. Typical fertilizer analysis of KCl is 0-0-60 (=52% K), where normal composition is 63%).

**Potassium Sulfate,  $K_2SO_4$ :** This fertilizer is used mostly for horticultural crops in which intake of chloride is a problem, as in tobacco. 0-0-50.

**Potassium Magnesium Sulfate,  $K_2SO_4+2 MgSO_4$ :** This is the essential potassium fertilizer invented by German and French mines from langbeinite ore and were called "double manure salts." The analysis is 0-0-18, but it also contains the secondary nutrients S (23%) and Mg (11%).

**Potassium Nitrate,  $KNO_3$ :** 13-0-44 (less the 14-0-47 of pure salt because of conditioners added against moisture). Formulated from KCl and nitric acid. Expensive for agronomic use, used for farming and green houses. Identical to "saltpeter" known to the ancients and recognized by Glauber in the 17th Century as the "principle of vegetation".

Other potassium sources include wood ash, which contains potassium mainly as a carbonate or hydroxide, and powdered rocks (e.g., granite) and minerals (alunite, orthoclase, microcline, etc.).

The release of potassium from the rocks and minerals requires weathering over long periods of time, although roasting the rocks with heat can bring the K out of the structure (but makes the potassium more expensive than that from the ores).

### **3.2.3 Methods of application:**

Since soil potassium is not that much available in soil, placement of potassium fertilizers with or near the seed is usually the most effective and efficient method of using potassium fertilizers provided the rate of application is not greater than the seed can tolerate. Potassium chloride (KCl) is a salt. If excess of potassium or a combination of other fertilizers that have a high salt concentration are placed with the seed, a “salt effect” can delay or reduce seed germination and emergence. Excess usage of fertilizer will interfere with the moisture uptake by the seed and may result in the death of a germinating seed.

The safe level of potassium that can be used with the seed depends on the crop. Normally, smaller seeded harvests, for example, canola have a lower resistance than oat crops. Dirt and Organic matter substance of the soil and the soil dampness substance will likewise affect conceivable germination issues. Soils with a higher dirt substance or higher organic matter substance can hold more water. This situation can reduce the salt effect slightly when soil moisture levels are good by diluting the amount of potassium salt dissolved in the soil water.

With normal soil dampness conditions and moderate-textured soils, the aggregate sum of seed-set manure/fertilizer materials ought not surpass 175 lb/air conditioning, and the aggregate sum of N in addition to K<sub>2</sub>O ought not surpass 40 lb/air conditioning at a seed-bed use (SBU) of 10 per cent..

These proposals depend on the utilization of a seed bore with a 10 per cent SBU, which puts the seed and compost/fertilizer in an extremely limited band. In the event that the opener spreads the seed over a more extensive band, higher rates of compost/fertilizer can be securely set with the seed.

**Side-band** placement is an efficient method of applying potassium which is much safer than seed placement, specifically when higher rates of potassium must be applied. Ideally, with this placement, the fertilizer is in a band approximately 2.5 cm (1 inch) to the side and possibly 2.5 cm (1 inch) below the seed. This separation of fertilizer and seed reduces the possible harmful effects on germination when high rates are applied. There are many different openers that have a little different placement positions.

**Banding**, also referred to as deep banding, places the potassium into the soil in a concentrated band next to seeding. It is trusted that this placement method ought to give comparable outcomes to side-banding K. Broadcasting potassium before seeding is less proficient than applying potassium in a band with or close to the seed. The major role for broadcast applications of potassium fertilizer will be in building up soils extremely deficient in potassium or for use with crops.

### **3.3 Soil collection procedure**

#### ***Sampling***

Difference in slope, soil colour and texture, crop growth and management was taken into account and different sets of samples were collected from different places.

#### **Sampling Procedure**

Dead furrow, old excrement, wet spots, ranges under or close to trees were abstained from amid sample collection. Surface litter was taken off utilizing a spade and a digger, a V-formed gap of between 20-25 cm profound burrowed and a 1.5 cm thick soil through and through of the gap was gathered and put in a perfect can. 10 tests were gathered randomly in a single area utilizing this strategies or methods. The samples from the ten spots in each location were thoroughly mixed in a bucket.

#### **Reduction of sample bulk**

This was done by reducing the soil sample collected to about 500 g. Diminishing was finished by separating the blended soil in four equal parts then disposing of two sections. The two residual examples were remixed and again isolated into four sections disposing of two then process was repeated until the required little sum was obtained. By passing the dry material through a 2 mm sieve, stones, large roots and other coarse fragments were removed. The soil was kept and lightly crushed in between sheets of polythene.

#### **Drying**

Drying was done under normal temperatures under shade where air circulation was present.

#### **Sample Storage and Transportation**

The soil samples were placed in paper bags, labeled A, B, C, D and E and had a note containing the following information:

Name of the location from which the sample was collected; depth of sampling, number of samples mixed to get representative sample, soil type ( coarse or heavy), crop growth (good/ poor/ average). The sampling record also included human influence such as grazing, manure applied, and burning of vegetation.

### **3.4 Potassium extraction method from soil:**

1. Pass the dried soil test through a 2mm sifter. Apportion 10ml of the sieved soil utilizing a scoop without tapping to abstain from compacting. Blending the dried soil with 50ml of the ammonium acetic acid solution, exchange to a 100ml poly ethane bottle. 2. Plug the jug, shake the container with the assistance of a shaker for 30 minutes (275 strokes for every min, 25mm travel).

3. After expelling from the shaker, permit to remain for a few minutes and after that tap the supernatant fluid through a dry Whatman No. 2 filter paper.

4. Prepared potassium standard solutions for cover the range 0 to 100 ppm potassium.

5. Progressively make the 20, 40, 60 and 80 ppm potassium standard solutions and set up an adjustment diagram.

6. Determine the potassium content of the soil extract by aspirating the solution, diluting as fundamental in ammonium acetate/acetic acid. By taking reference to the alignment diagram, we will quantify focus considering any diluting factors.

### **3.4.1 Determination of Potassium with Sodium Tetrphenylborate**

Sodium tetrphenylborate has come into prominence as a precipitant for potassium.

Tetrphenylborate salts are soluble in certain organic solvents. Dissolution in acetonitrile leads to a solvent medium that is especially well suited for spectrophotometric measurement

### **3.4.2 Preparation of Reagent Solution**

1. By using a digital scale 1.0 g of sodium tetrphenylborate had been measured and placed in a 100 ml volumetric flask.
2. 0.5 g aluminium nitrate had been measured in similar way and placed it in same flask.
3. Deionized water had been poured until it had touched the 100 ml mark. Than total solution had been shaken for few minutes so that all of them could mix well.
4. After this, total solution had been filtered through whatman filter paper and marked it as reagent solution.

### **3.4.3 Preparation of Sample Solution**

1, 3, 5, 10, 20 ppm potassium standard solution had been taken and marked to make sample solution. Each of them were 5 ml in volume. Besides this a blank sample had been taken and marked out too.

### **3.4.4 Preparation of Standard Potassium Iodide Solution**

Procedure for making standard KI solution is to take 144 gm KI for per 100 ml water. So, in order to make 20 ml solution 28.8 g KI had been taken and shaken until it was soluble in water.

## **3.5 Preparation of Sock Solution**

1. 6 conical flask had been prepared first
2. 5 ml of reagent solution had poured in each of flask



- 0,1, 3 ,5, 10, 20 ppm sample solution had been taken and added one by one in each flask. After adding them with reagent solution they were shaken mildly so that they could mix well.
- After mixing 3 ml of standard potassium iodide solution had been added in each of the flask
- Than we poured 47 ml of acetonitrile solution(75% acetonitrile+25% water) in each flask



**Stock Solution**

- Transfer 25ml of the 2000ppm potassium standard solution to a 100ml volumetric flask and dilute to 100ml with the ammonium acetate/acetic acid solution which will contain 500ppm of potassium.
  - Transfer 10ml, 20ml, 30ml, 40ml and 50ml samples of the 500 ppm potassium solution to 250ml volumetric flasks. Dilute to 250ml with the ammonium acetate/acetic acid solution and mix well.
- These solutions contain 20, 40, 60, 80 and 100 ppm potassium respectively.

## Chapter 4

# Circuit Analysis

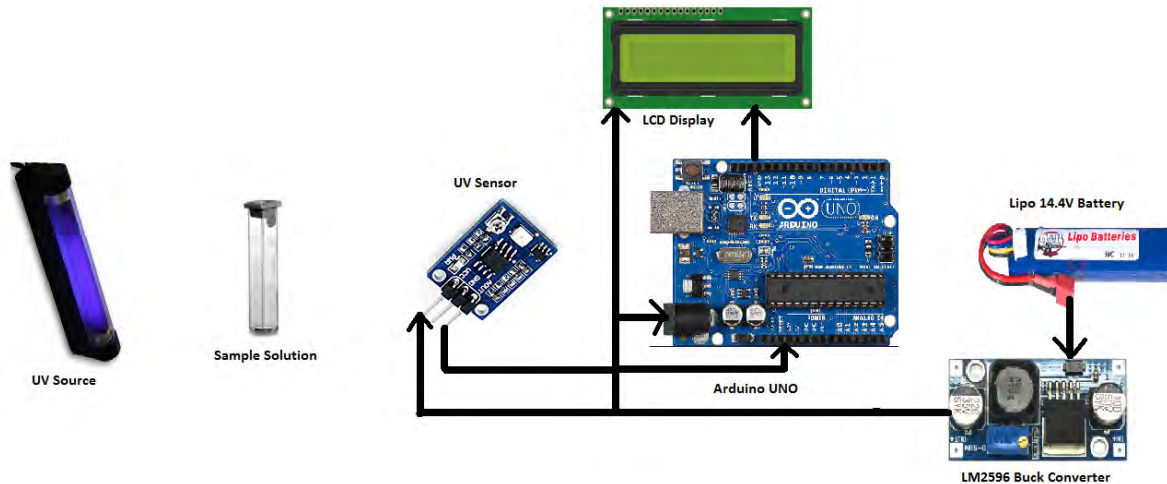

## 4.1 UV Sensor(UVM-30A)

A sensor actually works for sensing something. There are many kinds of sensor around the world. One of them is UVM-30A which is used for ultra violet radiation. The UV sensor is used for finding the intensity of incident ultraviolet radiation. This electromagnetic radiation has very small wavelengths rather than visible radiation. UVM-30A is made to detect high reliability and accuracy measurement in UV index. DC voltage 3-5V is its operating voltage. The output voltage of it is DC 0-1V. The current ranges 0.06 to 0.1mA. The response wavelength is 200nm-370nm. It responds more accurately and rapidly comparative to other sensor. It helps to monitor industrial equipments, elements and materials. It also helps to detect very small particles which are not visible in normal eye. It makes solar radiation for laboratory experiments and also ensures that proper doses of ultraviolet radiation are administered.



**Figure: UVM-30A.**

#### **4.1.1 Measurement Units**

Calibration factors for density units of energy flux and photon flux density are attached with each sensor allowing for rapid unit conversions.

#### **4.1.2 Output Options**

Analog and digital output both are available. Analog version is an un-amplified voltage output. Sensor is also available joined to a hand-held meter with digital readout.

## **4.2 Arduino Uno**

Arduino Uno is the most popular arduino for its working proficiency among all arduinos in the worldwide. Two or more devices can be attached easily by it. On the ATmega328, it is a microcontroller based board. It is dissimilar to other arduino because of its FTDI USB-to -serial driver chip. It has features like 14 digital input pins which also can be used as output pins, 6 analog input pins, a 16 MHz resonator, a USB, an ICSP button and a power button. The arduino programming is preferred for Uno programming. The preferable voltage is 3.3 volt and maximum current is 50mA for aarduino. External power supply can be given to arduino power supply. The power supply is selected manually. External power can be provided either from an AC-to-Dc adapter or from a battery. The adapter can be joined with a 2.1mm plug into the board's power jack. A battery can be joined in the GND and Vin pin is connected to the POWER connector. The board can operate accurately from 6 to 20 volts. If applied voltage is less than 7V, the 5V pin may supply less than five volts which make the board unstable. The voltage regulator may be overheated and so it may causes damage to the board for using voltage upper than 12V. So, the recommended range for good power supply is 7 to 12 volts.

### **4.2.1 The power pins which are used for Arduino Uno are discussed below**

1) Vin: This is the input voltage to the Arduino board at the time of using an external power source. Through this pin voltage can be supplied. If supply voltage is given by the power jack then it should be accessed through this pin.

2) 5V: From the regulator this pin outputs a 5V. The board can be supplied with power from the DC power jack which has voltage from 7 to 12V, the USB connector which has 5V and the VIN pin which has voltage from 7-12V. Supplying voltage applied by the 5V or 3.3V pins can bypasses the regulator and it can damage the board automatically. So it should not be done in this way.

3) Voltage and Current: The on-board regulator supplies voltage 3.3V. Maximum current is 50 mA through this board.

5) GND: These are the pins which are normally connected to the ground.

6) IOREF: This pin on the arduino board gives the voltage reference with which the microcontrollers can operate. A properly designed shield read the IOREF pin voltage easily and detect the appropriate power source. It also enables voltage translators on the outputs to work with the voltage either 5V or 3.3V.

### **4.2.2 Warning**

The Arduino Uno has a poly fuse which is resettable and it protects any computer's USB port from getting crashes or any kind of damages. The fuse gives an external protection properly where computer provides internal protection. If more than 500mA is used, the fuse will automatically disconnect the connection. This condition will continue until the short is removed.



**Figure: Arduino Uno**

## **4.3LiPo Battery**

A lithium polymer battery is a kind of battery which is rechargeable .LiPo is prepared based on lithium-ion technology where instead of common liquid electrolyte, a polymer electrolyte is used. These batteries are mainly partially charged. Unlike other cells, LiPo has come in a soft package. It makes them lighter but also less rigid. Mainly, "lithium polymer" represents a new way for using a polymer electrolyte without the usage of common liquid electrolyte. The result is a plastic cell which could be thin, flexible, and manufactured in different shapes. There is no risk of electrolyte leakage. LiPo batteries are generally safe rather than other batteries like NiCdan NiMH.

### **4.3.1 Specification**

- 1) Low impedance can deliver high currents.
- 2) Voltage is very good and important indicator for the state of charge.

- 3) Polymer based electrolyte.
- 4) Battery expands at the time of charging.
- 5) Vulnerable to deep discharge and
- 6) Hydrogen can form when overcharging.



**Figure: LiPo battery**

#### **4.3.2 Working principle**

LiPo batteries normally work like other batteries. But its working function is much better than other batteries. Like other lithium-ion cells, LiPos work basically on the precept of intercalation and de-intercalation of lithium ions from a electrode of positive material and an electrode of negative material and it provides the liquid electrolyte a conductive medium. A small separator is placed in between electrodes which allow only the ions and not the electrode particles to go from one side to another. It prevents the electrodes from touching each other directly. LiPo cells helps providing producers with forcing reward. Batteries of any shape can be easily produced of their own choice. As an example, weights and spaces needed for mobile phones and notebook computers can be completely satisfied. They have important factor which is their low discharge rate and that is only 5% per month.

#### **4.3.3 Application**

LiPo batteries are spreading rapidly throughout in mobile phones, tablet computers, thin layer laptop, mini computers, media players with portable, wireless video game controller consoles and other applications where small form factors are needed and the high energy density outweighs the cost.

#### **4.3.4 Safety**

LiPo cells are affected with some problems like other lithium-ion cells. It is caused because of overcharge, high-temperature, high discharge, short circuit and crush etc. These all may create a large failure, the electrolyte leaking and also fire.

On the other hand, all cells in a LiPo battery maintain the same voltage across all cells at all times. If the voltages across the cells degenerate too much like 5mV to 10mV, the battery will be dangerous. The battery also becomes unstable. A fire proof safety bag should be used while charging, discharging and storing. LiPo fires are rare but when it occurs, it can do a lot of damage. All Li-ion cells enlarge at high levels when it gets over charging or over discharging because of slight vaporization of the electrolyte. This may damage the internal layers of the cell.



**Figure:LiPo battery**

#### **4.4 Buck Converter**

A buck converter is a power converter which basically converts power from DC-DC .It basically steps down the voltage from its input to its output. It is a kind of switched-mode power supply. To prepare a buck converter, necessary materials which is needed –

1. A capacitor,
2. Two semiconductors
3. One energy storage element and
4. Inductor.

Filters which have capacitors are normally connected to a converter's output and input which helps to reduce voltage ripple. Switching converters give more power efficiency as DC-to-DC converters than linear regulator. These are simpler circuits that reduce voltages by dissipating power as heat.

Buck converters have more efficiency which is approximately 90%.So it is useful for many important useful tasks to established-like converting a computer's main supply voltage down to small voltages needed by USB, DRAM and the CPU which has less volts than 1.8 volt.

### 4.4.1 Theory of Operation

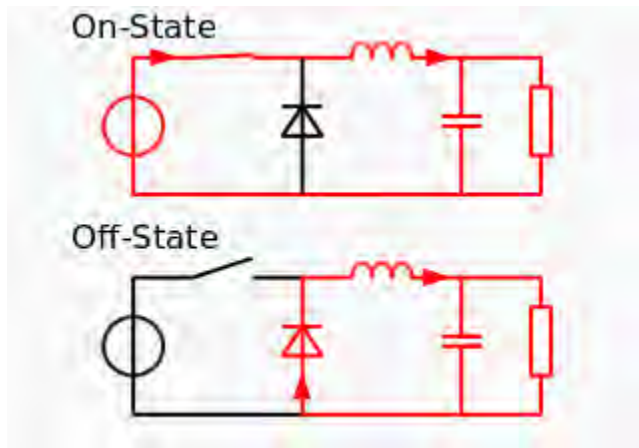

**Figure-1**

Figure1:

Configuration of a buck converter is not that much critical. These two circuits are configurations of a basic buck converter.

On-state: when the switch is OFF and

Off-state: when the switch is ON.

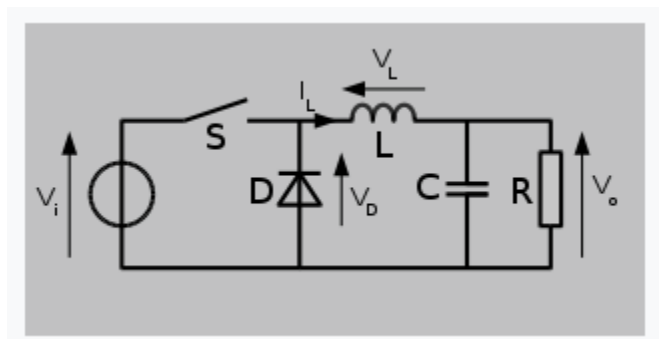

**Figure-2**

Figure-2:

Continuous mode:

A buck converter can operate continuously if the current passing through the inductor never falls to zero at the time of completing the cycle.



- When the switch shown in the picture is closed, the diode is reverse-biased. In this mode, the current through the inductor increases linearly. When the diode is reverse-biased, no current flows through this.
- When the switch is opened, the diode is forward biased. The voltage across the inductor does not care whether voltage drops or not.

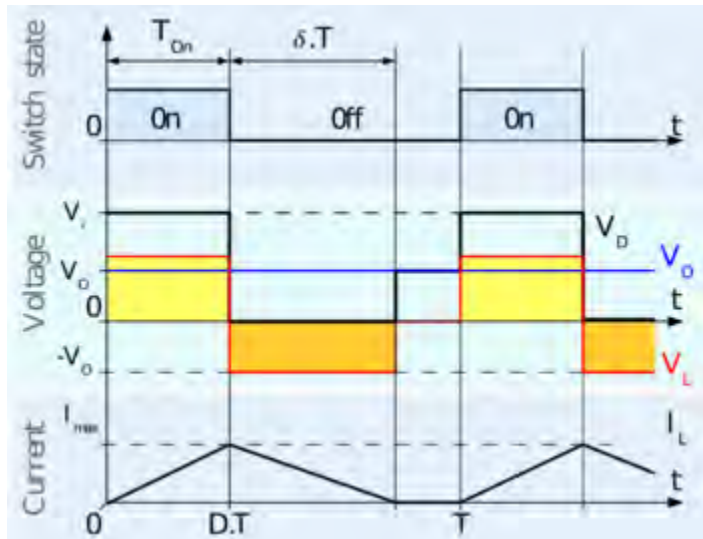

**Figure-3**

Measuring the voltages and currents with times for a buck converter while it is working in discontinuous mode.

Discontinuous mode:

Sometimes, the amount of energy is needed by the load is very small. In this case, the current through the inductor falls to zero. The only difference is that the inductor is completely discharged in the last of the commutation cycle. This has some effect on the previous equations too. When the inductor current is less than zero, it creates discharging of the output capacitor at the time of every cycle. Therefore it creates higher switching losses. Pulse-frequency modulation is used to eradicate these losses. Even after that it is considered that the converter operates in a state which is constant. The energy in the inductor is the same at the starting point and also at the end of the cycle.

#### **4.4.2 Multiphase Buck converter**

The multiphase buck converter is another type of circuit where basic buck converter circuits which are placed in parallel between the input and load. In total period of switching, each of the  $n$  phases is turned on at equally separated intervals. This circuit is basically used with the synchronous buck topology which is described above. It is not like other buck converter.

This type of converter can respond to load changes very quickly because it switched n times faster. Moreover, it can respond very rapidly like modern microprocessors.



**Figure-4: Multiphase Buck converter**

#### **4.4.3 LM2596 Buck converter**

It is another buck converter which integrated the circuit with a step down switching. A load of 30A can be driven by it easily. It has adjustable output to minimize the number of other components to specify power supply voltage. It has output voltage of 1.23-37V. Output load current is 30A. Low power standby mode and thermal shutdown is the features of this converter. It is applicable for Simple high-efficiency step-down, negative step-up and positive to negative converter.



**Figure:LM2596 Buck Converter.**

## **4.5 Liquid Crystal Display**

LCD is the latest technology which can be useful for displays in notebook, small computer digital watch and many more. LCDs displays are much thinner than cathode ray tube technology which is known as CRT. It has similarities with light-emitting diode (LED) and gas-plasma technologies. LCD does not need more power like LED. Another advantage is it does not need gas-display displays because those are used for the principle of blocking light rather than emitting it.

### **4.5.1 How actually LCDs work**

There can be three types of states for any substance. They are solid, liquid and gaseous. Solids do not change their position and remain in the same orientation. By moving from one position to another liquid can change their position. Apart from these, there are some substances which can be either a liquid or also acts like solid. When they are in this position, their particles want to maintain the orientation and at the same time they move around to different positions. So liquid crystals are not specifically a solid or liquid. Moreover it is closer to a liquid state than a solid. It needs a minimum amount of heat to change a suitable substance from a solid into a liquid crystal. A passive matrix or an active matrix display grid helps to prepare an LCD. LCD is known as a display of thin film transistor when it made with active matrix. Current is provided to control the light for any pixel by the two conductors. In every pixel intersection, an active matrix has a transistor. The transistor requires small current to manage the brightness of a pixel. That is why the current in an active matrix display can be switched on and off more frequently and it also improves the screen refreshing time.

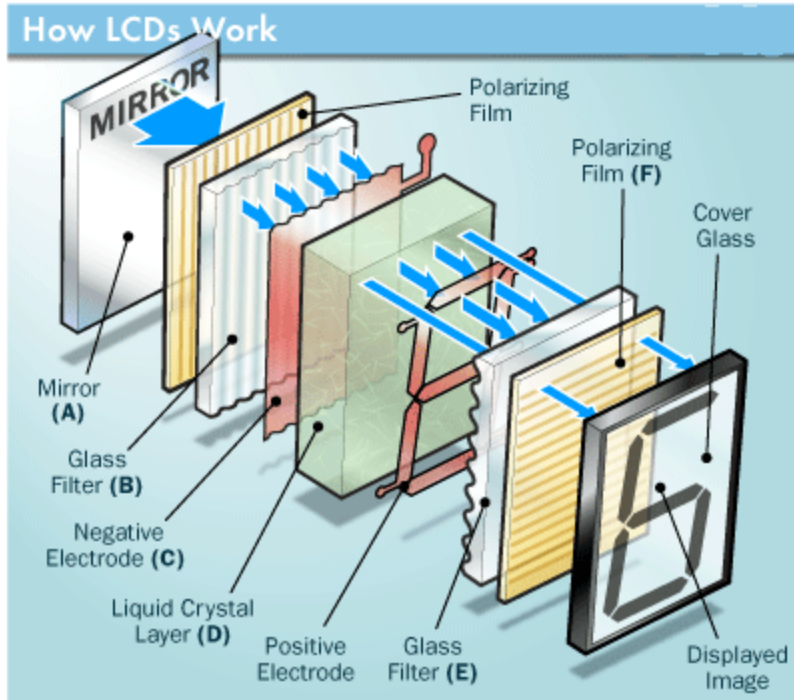

**Figure: Liquid Crystal Display.**

#### **4.5.2 Things which should be followed preparing an LCD**

At the time of preparation of LCD, some basic rules should be followed like-

1. Other transparent substances can interrupt and involve.
2. The liquid should be able to transmit from one place to another.
3. The light either be polarized or not.

A liquid crystal cell has a very small layer which is approximately like 10 $\mu$ m. It is a crystal which is pressured in between two glass sheets. At the time of applying pressure, transparent electrodes inserted on their inner faces. The both glass sheets transparent are not same kind of cell. When one glass is transparent and the other has a reflective coating, the cell can be reflective. The LCD does not make any lights of its own. Actually, it has to depend totally on light falling on it coming from an outer source and it helps working for its visual effect.

# Chapter 5

## DATA ANALYSIS

As mentioned earlier we took 6 samples from the stock solution of amount 0ppm, 1ppm, 3ppm, 5ppm, 10ppm, 20ppm. We tested these solution in a UV spectrophotometer and we go some data which is illustrated below.

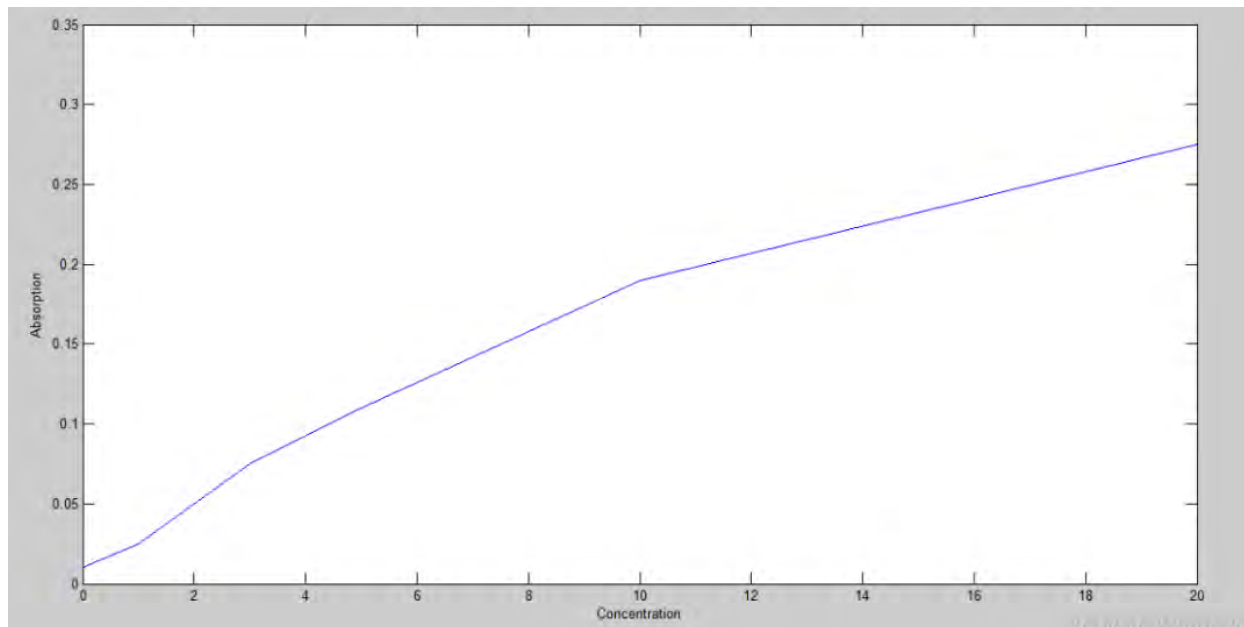

FIGURE: OVERLAY SPECTRUM GRAPH REPORT

From the above plot we can observe that we get maximum absorbance at the wavelength of 360nm.

Now, we will collect 6 stock solutions just like before and will examine them by our own device where we will be using a UV portable light source which has a wavelength of 254nm.

Experiment 1:

0 ppm	3.6 mV
2 ppm	75.0 mV
5 ppm	97.6 mV
10 ppm	113 mV
20 ppm	129.3 mV

## EXPERIMENT 2:

0 ppm	42.9 mV
1 ppm	78.6 mV
3 ppm	92.5 mV
5 ppm	99.8 mV
10 ppm	114.5 mV
20 ppm	131 mV

By taking these two sets of data we have plotted 2 graphs which is given below:

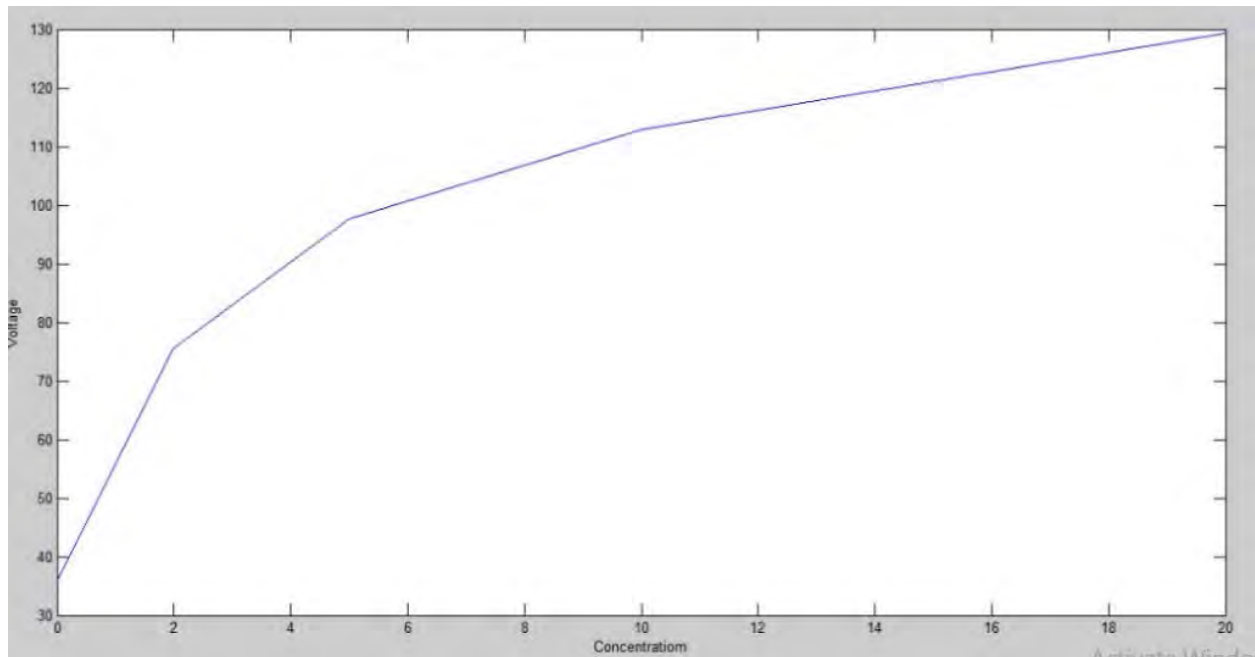

FIGURE: GRAPH FOR EXPERIMENT 1

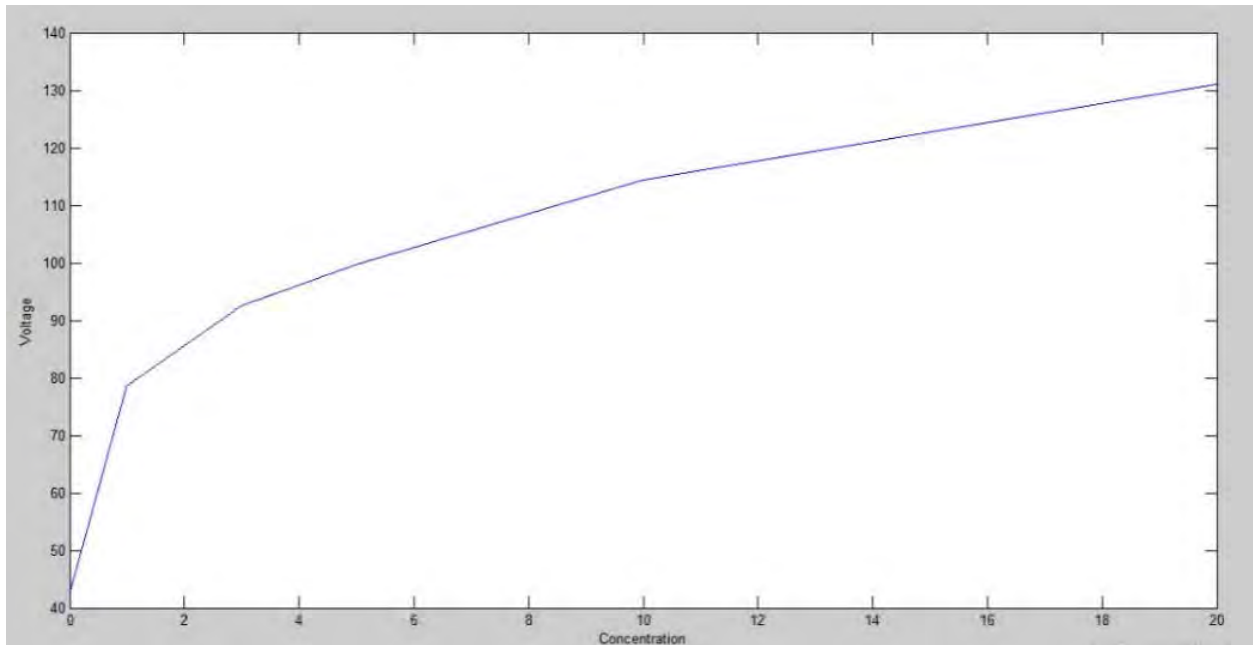

FIGURE : GRAPH FOR EXPERIMENT

By analyzing the overlay spectrum graph we found that it is a straight line which support Beer-Lambert law. Now if we analyze both of our plots we can observe that we also have two partially linear/ straight graphs. This is because the wavelength we used was 254nm and in the spectrophotometer we got a peak at 360nm and while performing the experiment our device was slightly exposed to sunlight and hence effected the result.

# Chapter - 6

## Reference

1. <http://teaching.shu.ac.uk/hwb/chemistry/tutorials/molspec/uvvisab3.htm>
2. Atomic Absorption Spectroscopy, Edited by Muhammad AkhyarFarrukh
3. <http://www.rajaha.com/atomic-absorbtion-spectroscopy-instrumentation-applications/>
4. <https://www.scribd.com/document/296189873/Spectrophotometer-Modern>
5. <http://www.rajaha.com/flame-photometry/>
6. <https://www.ocf.berkeley.edu/~jmlvll/lab-reports/AASalloy/AASalloy.pdf>
7. <http://www.indiastudychannel.com/resources/146681-Principle-working-and-applications-of-UV-spectroscopy.aspx>
8. <http://www.smart-fertilizer.com/articles/potassium-in-plants>
9. <http://soils.wisc.edu/facstaff/barak/soilscience326/macronut.htm>
10. *Typical concentrations sufficient for plant growth*. After E. Epstein. 1965. "Mineral metabolism" pp. 438-466. in: Plant Biochemistry (J. Bonner and J.E. Varner, eds.) Academic Press, London



# Chapter - 7

## Appendix

### Code Section:

#### Arduino Source Code for UV Sensor:

```
/*
AnalogReadSerial
Reads an analog input on pin 0, prints the result to the serial monitor.
  Graphical representation is available using serial plotter (Tools >
  Serial Plotter menu)
  Attach the center pin of a potentiometer to pin A0, and the outside pins
  to +5V and ground.
```

This example code is in the public domain.

```
*/
/*
LiquidCrystal Library - Hello World
```

Demonstrates the use a 16x2 LCD display. The LiquidCrystal library works with all LCD displays that are compatible with the Hitachi HD44780 driver. There are many of them out there, and you can usually tell them by the 16-pin interface.

This sketch prints "Hello World!" to the LCD and shows the time.

The circuit:

```
* LCD RS pin to digital pin 12
* LCD Enable pin to digital pin 11
* LCD D4 pin to digital pin 5
* LCD D5 pin to digital pin 4
* LCD D6 pin to digital pin 3
* LCD D7 pin to digital pin 2
* LCD R/W pin to ground
* LCD VSS pin to ground
* LCD VCC pin to 5V
* 10K resistor:
* ends to +5V and ground
* wiper to LCD VO pin (pin 3)
```

Library originally added 18 Apr 2008  
by David A. Mellis

library modified 5 Jul 2009  
by Limor Fried (<http://www.ladyada.net>)  
example added 9 Jul 2009  
by Tom Igoe  
modified 22 Nov 2010  
by Tom Igoe

This example code is in the public domain.

```
http://www.arduino.cc/en/Tutorial/LiquidCrystal
*/

// include the library code:
#include <LiquidCrystal.h>

// initialize the library with the numbers of the interface pins
LiquidCrystal lcd(12, 11, 5, 4, 3, 2);

// the setup routine runs once when you press reset:
void setup() {
  // initialize serial communication at 9600 bits per second:
  Serial.begin(9600);
  // set up the LCD's number of columns and rows:
  lcd.begin(16, 2);
  // Print a message to the LCD.
  lcd.print("K Detector");
}

// the loop routine runs over and over again forever:
void loop() {
  // read the input on analog pin 0:
  float sensorValue = analogRead(A0);

  float millivolt = ((sensorValue/1024)*1000);

  // print out the value you read:
  Serial.print("sensor Value as ADC = ");
  Serial.println(sensorValue);
  Serial.print("sensor Value as Millivolt = ");
  Serial.println(millivolt);
  Serial.println();
  lcd_print(millivolt);
  delay(500);          // delay in between reads for stability
}

void lcd_print(float millivolt)
{
  lcd.setCursor(0, 1);
  // print the number of seconds since reset:
  String STR = String(millivolt) + (" ") + ("mV") ;
  lcd.print(STR);
}
```