

## **AUTOMATION, HEAT LOSS REDUCTION AND OPTIMUM POSITIONING OF SOLAR HOT WATER SYSTEM WITH STORAGE TANK IN BANGLADESH**

Jannatul Ferdous

*Control & Applications Research Centre  
Department of Electrical and Electronic Engineering, BRAC University  
66 Mohakhali C/A, Dhaka 1212, Bangladesh  
email: jannataquarian15@gmail.com*

Rafiur Rahman Surjo

*Control & Applications Research Centre  
Department of Electrical and Electronic Engineering, BRAC University  
66 Mohakhali C/A, Dhaka 1212, Bangladesh  
email: rafiur@bracu.ac.bd*

Raied Hasan

*Control & Applications Research Centre  
Department of Electrical and Electronic Engineering, BRAC University  
66 Mohakhali C/A, Dhaka 1212, Bangladesh  
email: mraiedhasan@ieee.org*

AKM Azad

*Control & Applications Research Centre  
Department of Electrical and Electronic Engineering, BRAC University  
66 Mohakhali C/A, Dhaka 1212, Bangladesh  
email: a.azad@bracu.ac.bd*

### **ABSTRACT**

Since time immemorial, the necessity for hot water has been indispensable regardless of the advent of modern technology. In the dawn of the 21st century, only the means to heat the water has changed - now we mostly use electricity and gas in place of woods and other natural fuel. With that being said, lots of gas and electricity is being devoted to heat up the liquid for uses in hospitals, industries and households and the demand for hot water is ever climbing. Natural resources like fuel and coal are in limited amounts and will not be able to sustain forever. Consequently, renewable energy is starting to gain popularity in countries like Bangladesh. As a commitment to the development of the energy sector of Bangladesh, Control and Applications Research Centre (CARC) of BRAC University has developed a Solar Hot Water System (SHWS) that would utilize solar energy to heat water, which could be used for several purposes like sterilization of medical equipment, cleaning of dishes, etc. An automated pilot project has been implemented on the rooftop of BRAC University and research work has been conducted for increasing the efficiency of the whole system by increasing the captured insolation and reducing wastage of heat overnight through insulation of the storage tank. With regard to procedural perspectives, this paper contemplates on highlighting the technology implemented in the system and the improvisations made to elevate the efficiency and present a viable comparison between commercially available hot water systems with the developed automated uninterruptable SHWS.

**Keywords:** solar hot water system, automation, thermal insulation, Bangladesh Rural Advancement Committee (BRAC)

## Introduction

Due to its location in the tropical region, Bangladesh enjoys copious levels of sunlight for most part of the year. The annual amount of radiation in Bangladesh varies from 1575 – 1840 KWh/m<sup>2</sup> [16]. The aforementioned solar hot water system has been built from the ground up with the aim of utilizing this abundant green energy for heating water for both domestic and industrial use. The primary function of any solar thermal energy system is to convert solar energy directly into heat in an efficient manner for a specific application. Conceptually, a solar thermal system consists of a “solar collector” to capture solar energy and convert it directly to heat and a mechanism for transporting the collected heat to a location where it is needed to offset a thermal load. Typically, energy is removed from a solar collector by a heat transfer fluid (in this case water) that is heated as it is pumped through the device. The heated fluid is then transported to a thermal storage for use at another time or circulated directly to supply the load. The capability of the storage to deliver its stored energy at as high energy as possible is an important aspect. Since stray heat loss is inevitable, by sustaining a high temperature in the thermal storage, this goal is duly fulfilled. It is worth mentioning that these systems tend to be small and relatively cost effective. A solar hot water heating system for a typical household consisting of four individuals would have a solar collector array of 4 to 6 m<sup>2</sup> and a hot water storage tank of 150 to 300 litres.

## Contribution of This Research

The scope of this paper incorporates research conducted over a span of one year [1,2,3,4,5,6]. It has to be noted that it is an extension of a previously implemented solar hot water system, which did not have any use of microcontroller for automation of the controller [6]. The approach taken during the course of this research focused primarily on an experimental evaluation of the full-scale thermal storage apparatus. Considerable effort was undertaken to design, construct, instrument, commission and calibrate the apparatus. The primary focus of this solar hot water system project is to: 1) design an active, automated solar hot water system through integration of micro-controller in the control system, 2) reduce heat loss overnight from the system through insulation of the storage tank and 3) increase the

amount of captured heat by optimum positioning. The interface of the controller has been made as user friendly as possible. Various materials have been tried for insulation and the performance of the SHWS in terms of heat loss has been enhanced, subsequently. Optimum positioning of the collector for Dhaka, Bangladesh has been determined through determination of optimum tilt factor. All the components of the controllers are readily available in Bangladesh and hence large scale production of it is also possible, saving huge amount of money required for importing the controllers. This new approach towards automating the whole system can highly promote the use of SHWS in Bangladesh and elsewhere.

## Mechanism of the Designed System

The system is composed of a solar collector (150 litres), a storage tank (300 litres), an electric water heater, five solenoid valves, two temperature regulators, a temperature regulator, a controller, a 16x2 characters LCD and two pairs of seven segment displays. Fig. 1 shows the basic overview of the system. The specifications of the collector and the tanks are given in Table I.

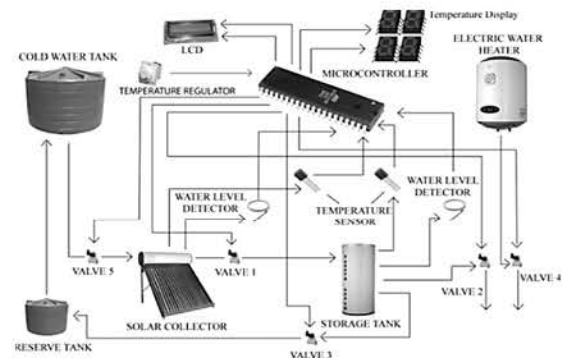

Fig 1. Overview of the system [3]

Table I. Specifications of the solar collector and the tanks

Size of the collector (Length)	5 ft 6 inch.
Size of the collector (Width)	7ft 9 inch
Capacity of the Solar Water Heater	150 Litre
Capacity of the Storage Tank	300 Litre
Number of the collector for 150L storage tank	15 tubes
Diameter	0.045 meter
Length	1.8775 meter
Total area for 15 collector	1.99 sq.meter

The developed automatic controller is the main device that is responsible for the functionality of the whole system. The backbone of the controller is the micro-controller that holds the algorithm for the operation of the whole system. Atmel's ATmega32 microcontroller has been chosen for advantages like its large flash memory along with other built in A/D converter. By determining the temperature and the level of water in each tank, it controls the flow of water by providing the control signals to the relays, which in turn drives the corresponding valves on and off. Alongside the main microcontroller, a second ATmega32 is used to drive the LCD. A functional block diagram and a schematic diagram of our developed controller section are shown in Fig. 2 and Fig. 3 respectively. There are various controllers [7, 8, 9, 10, 11, 12, 13, 14, 15] already in the market but not in Bangladesh. Those controllers are mainly for automation in industries because of their complexity. Based on Programmable Logic Controller (PLC) and Proportional Integral Derivate (PID) controller, these controllers are not for technically unsound people. Water level detectors and temperature sensors are the autonomous inputs to the controller. The water level detector is made using wires and copper tubes. The level detectors detect level in discrete levels as opposed to industrially manufactured continuous scale detector. For the 150 litres solar collector tank, there are three levels of indicators (10 litres, 50 litres and 150 litres) and three transistors are responsible for feeding the signal to the microcontroller. For the 300 litres storage tank, there are four levels of indicators (10 litres, 100 litres, 200 litres and 300 litres) corresponding to the four different transistors. Inside the copper tube of the detectors, a LM35 has been placed making it a combined device for water level detector and temperature sensor for each tank. The temperature sensors and the level detectors, located inside the tank of the collector and the storage tank, feed signals to the controller which then drives the solenoid valves connected between various junctions of the pipeline of the system. Five solenoid valves are connected in total to the system: at the inlet of the 150 litres tank (valve 5), between the 150 litres tank and 300 litres tank (valve 1), between the 300 litres tank and the user output (valve 2), between the alternate water heater and user output (valve 4) and between the 300 litres tank and the reservoir tank (valve 3).

These valves, rated at 24 volts, are controlled by relays, which are energized through five transistors (see Fig. 3) that are controlled by the micro-controller. Fig. 4 shows a picture of solenoid valve. The valve opens if 24V is applied across it.

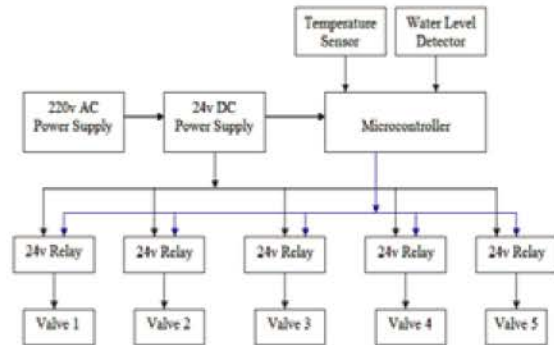

Fig. 2. Block diagram for the controller [3]

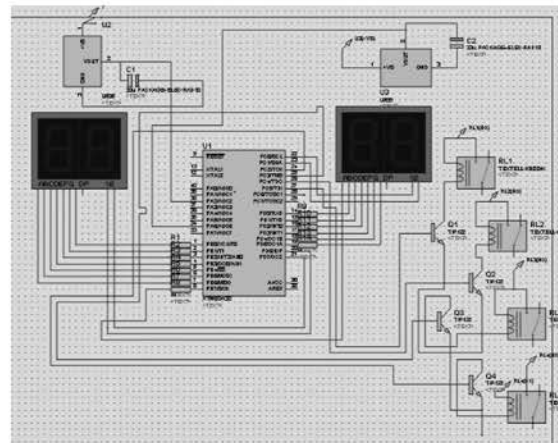

Fig. 3. Schematic diagram of the controller [3]



Fig. 4. The solenoid valve

The LCD display shows the water level inside the tanks and the operating temperature pre-set by the user using the temperature regulator. The connected 7-segment displays along the controller show the temperature inside the 150 litres and the storage tank. The design of the controller has been optimized for users so that no technical training or knowledge is required for operating it. The inputs for the controller are a simple regulator to set the temperature of the hot water that the user wants and a tactile button to push for confirming the temperature. The interface has been bug tested for flaws and in case the user enters anything wrong, it can be corrected on the fly by holding the button for few seconds and resetting the process for re-entry. Thus, this system can be very effective for domestic households.

### Algorithm of Automation

The sequential algorithm for the whole operation is shown in the flowchart in Fig. 5. Initially, the user sets a temperature using the control panel comprised of buttons and the LCD. The system begins by checking if the solar collector (150L tank) is empty. If it is, valve 5 is opened to let water flow in from the cold water tank. Once the collector is determined full, valve 5 is closed and the water is contained in the collector for heating. Once its temperature rises to or stays above the

user desired temperature (e.g. 60°C), it is checked whether the 300L storage tank is full or not. If not, valve 1 is opened to let the hot water enter the storage tank. Valve 2 is held open as long as the temperature and the level of the water in the storage tank remain above a predetermined value (e.g. 45°C) to supply the water to the user outlet. To mitigate overflows in the storage tank, an overflow pipe of sufficient height has been installed. If the water temperature in the storage tank falls below the predetermined temperature, valve 2 is held shut while valve 3 is opened to recycle some of the water back to the reserve tank where it cools and gets back to the cold water tank and valve 4 is opened to meet the user demand from the auxiliary water heater. If the collector is determined to be empty after the discharge, valve 1 is closed and valve 5 is turned on to fill it up and the whole cycle is executed again.

### Elucidation of the heat up process

Water is heated up by the solar collector during the day and transferred to the storage tank at dusk. The maximum temperature of the water in the collector during heating and the temperature of the water in the storage tank in the following morning are noted. The storage tank temperature which had the least drop was selected as the operating temperature of the system. The temperature variation of the 150 litres water tank of the whole day for one week was recorded. It is found that the temperature of the hot water tank rose up to (on a full sunny day) 68 degree Celsius and in cloudy days up to 56 degree Celsius (see Fig. 6). Storage of water at 68°C causes higher loss of heat due to greater temperature difference with the ambient temperature. If water is stored at 50 degree Celsius, the temperature fall of 300 litres storage tank is only 2 degree Celsius, which is the minimum temperature drop among any other stored water temperature. Therefore, 50 degree Celsius temperature has been selected as the operating temperature of our solar hot water system. This 300 litres water stored in the water tank changes the temperature with an average of 4% drop over 24 hours, which is very acceptable since solar heating is almost a continuous process [5, 7]. The minimum efficiency of the system is determined by the amount or temperature of hot water required during winter (when the largest amount of hot water is often required). The maximum efficiency of the system is determined by the need to prevent the water in the system from becoming too hot (to boil, in an extreme case).

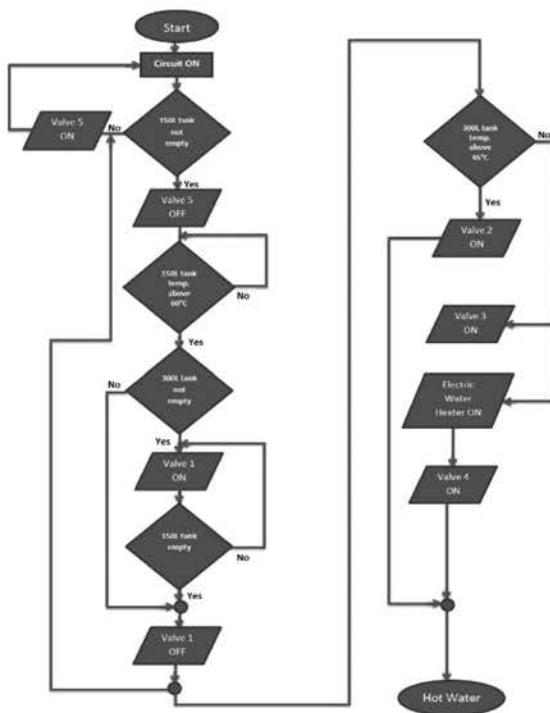

Fig 5. Algorithm of the system [3]



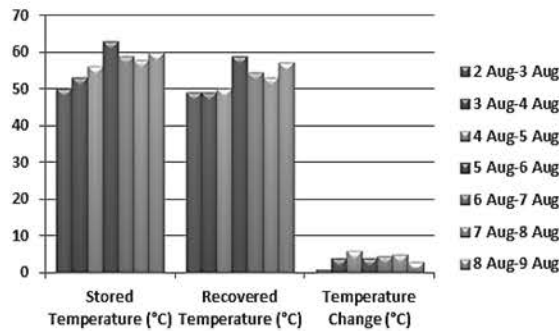

Fig 6. Stored temperature, recovered temperature and temperature change chart of one week in August 2010 [5]

### Performance Comparison

The performance of the designed SHWS was compared with commercially available SHWS. The analysis is given in Table II. Alongside, the payback calculation of the system has also been done [5], which indicated that the payback of a 450 litres automatic solar hot water system is around 14 years.

Table II. Comparison of the designed system with another commercial hot water system [3]

Context	Designed Solar Hot Water System	Commercial Hot Water System
Alternate heating method	Equipped with storage tank for storing water and contains electric water heater for alternate supply	Equipped with gas or electric boosters to ensure uninterrupted water supply [18]
Mode of Operation	Automatic Solar Hot Water System	Manual Solar Hot Water System
Storage Tank	Equipped with extra storage tank for storing and supplying hot water	System may contain several tanks but all of them act as primary tanks [18, 3]
Complexity	The system is fully automatic and does not require any form of human interference apart from periodic matter. Troubleshooting is relatively easy because of using Microcontroller	The automatic systems use complex integrated and mechanical systems that might not be favourable for using at home [3].

### Heat Loss Reduction

The Solar Hot Water System (SHWS) has already been designed and implemented. Further research has been conducted on its thermal insulation at variable time, temperature and solar radiation conditions to reduce the temperature drop of the stored water overnight. Thermal insulation is the reduction of the effects of the various processes of heat transfer between objects in thermal contact or in range of irradiative influence. The factors that are considered for choosing insulation material are the availability, thermal resistance (R) and thermal conductivity (k) of the insulator material. Thermal resistance, R, is a measure of thermal resistance, under uniform conditions it is the ratio of the temperature difference across an insulator and the heat flux (heat transfer per unit area, QA) through it [1]. R-values are given in SI units, typically square-meter Kelvin's per watt or m<sup>2</sup>·K/W. The higher the thermal resistance, the better the insulator.

$$R = \Delta T / QA \quad (1)$$

The K value or thermal conductivity is usually measured in Watts per meter per degree Celsius (Kelvin) abbreviated as W/m/k (SI unit); the lower this number, the better the insulator. Thermal conductivity can be calculated by dividing the thickness (t) of the insulator by the thermal resistance. The lower the thermal conductivity the better the insulator.

$$k = t / R \quad (2)$$

R and k values are closely related in that they are different representation of the inherent insulating ability of the material. They describe how good a conductor of heat the material is. A wide range of insulation materials is available, selection of insulation material should be based on thermal conductivity, moisture vapour permeability, safety features, the adaptation of its form/shape to that of the collector and tank and the installation methods available. From an economic point of view, it may be better to choose an insulating material with a lower thermal conductivity rather than increase the thickness of the insulation in the hold walls. By reducing the thermal conductivity, less insulation will be required. Different materials were analysed based on their price and availability in Bangladesh and the characteristics are noted in Table III.

**Table III. Insulating materials**

Insulating material	"R" value per inch (2.54 cm)	Advantages	Disadvantages
Cork board	3.33	Available, reasonable cost, can be covered with fibreglass	Lower R-values than polyurethane for styrene foams
Fibreglass wool batts	3.3	Low cost, ease of installation	Readily absorbs water or other fluids, loses insulating value when wet
Rock wool batts	3.7	As above	As above
Wood shavings	2.2	Readily available, low cost	Absorbs moisture and loses R-values when wet, decays

### Capacity Evaluation

The 300 litres storage tank and collector pipes were insulated with aluminum foil and cork board. The pipes through which water is transferred from the 150 litres collector tank to 300 litres storage tank is insulated with rubber. The front side of the collector tube is insulated by the aluminum foil and the back side of the tube is covered with cork and aluminum foil to reduce heat escaping (see Fig. 7).



(a) Front side



(b) Back side of the storage tank

Fig 7. (a) Front side (b) Back side of the storage tank

Water was heated up during the day and the temperature of the water stored in the storage tank was measured throughout the night. The water temperature was again measured in the morning to find the temperature difference. The procedure was repeated with and without insulation to find the performance. The performance analysis of the SHWS with and without insulation is shown in Table IV.

**Table IV. The performance analysis of the SHWS with and without insulation**

Without Insulation			With Insulation		
Storage tank temp in °C at night	Storage tank temp in °C at morning	Loss is temp in °C	Storage tank temp in °C at night	Storage tank temp in °C at morning	Loss is temp in °C
67	56	11	45	38	7
67	58	9	45	39	6

### Estimation of GHI and DIF

Global Horizontal Irradiance (GHI) and Diffuse Fraction (DIF) data was collected from the final report on Solar and Wind Energy Resource Assessment (SWERA) – Bangladesh Project [8]. The fraction of diffuse radiation which was obstructed by the surrounding obstacles (inclined > 5°) were added with the measured GHI values. From a study of the surrounding obstructions it was found that 2% area of the hemisphere was obstructed. To get reliable diffuse radiation values, necessary correction factors were introduced. For measurements pyrometer and two hand data loggers were used. Table V and table VI shows the average GHI and DIF over respectively for Dhaka city over the whole year.

**Table V. Monthly average GHI (Wh/m<sup>2</sup>) in Dhaka [16]**

Hours/month	Jan	Feb	Mar	Apr	May	Jun	Jul	Aug	Sep	Oct	Nov	Dec
5:30	3	8	29	66	106	93	86	66	58	46	31	11
7:30	57	93	148	198	252	200	188	180	165	169	157	97
9:30	175	254	318	354	406	321	355	288	303	324	331	237
11:30	300	424	489	521	561	416	438	433	435	473	490	382
13:30	411	573	639	666	681	494	503	514	483	487	580	479
15:30	494	672	712	751	727	532	548	537	485	520	614	498
17:30	518	701	722	764	711	543	570	535	486	488	573	488
19:30	483	640	657	694	643	500	503	487	441	406	510	426
21:30	379	528	541	553	577	451	463	453	385	323	377	309
23:30	236	353	377	402	419	329	372	336	281	208	204	183
16:30	94	175	204	237	257	215	244	231	164	76	57	54
17:30	10	37	55	72	93	93	107	89	45	6	1	2
18:30			2	4	11	17	18	8	1			
Daily average (kWh/m <sup>2</sup> -day)	3.16	4.46	4.88	5.28	5.46	4.22	4.42	4.18	3.74	3.53	3.92	3.17

**Table VI. Monthly average hourly DIF (Wh/m<sup>2</sup>) in Dhaka [16]**

Hour/Day	Jan	Feb	Mar	Apr	May	Jun	Jul	Aug	Sep	Oct	Nov	Dec
5:30	3	7	27	58	90	80	70	58	55	37	23	10
7:30	47	70	109	147	183	145	140	137	108	87	59	39
9:30	117	146	189	218	253	228	220	217	229	172	137	109
11:30	172	203	244	308	322	281	287	292	279	238	176	145
13:30	220	250	281	350	356	325	318	343	327	248	205	171
15:30	250	274	297	372	381	339	349	350	333	263	223	194
17:30	257	264	306	367	375	348	356	342	304	268	217	208
19:30	240	254	276	339	345	317	295	319	260	219	206	193
21:30	199	221	243	284	303	282	250	270	259	173	167	156
23:30	139	170	191	217	238	215	211	224	187	122	110	105
16:30	69	104	127	151	164	152	149	157	115	55	43	40
17:30	9	30	46	60	77	75	82	68	38	5	1	2
18:30			1	4	12	15	16	7	1			
Daily average (kWh/m <sup>2</sup> -day)	1.72	1.99	2.34	2.90	3.12	2.85	2.76	2.79	2.54	1.91	1.60	1.39

**Determination of Tilt Factor**

To use horizontal total radiation data for estimating the radiation on the tilted surface plane of a collector of fixed orientation, it is necessary to know the ratio of total radiation on a tilted surface to that on the horizontal surface [16][19][20]. The amount of solar radiation falling on a tilted surface is the sum of the beam and diffuse radiations falling directly on the surface and the radiation reflected on the surface from the surroundings. If the tilt factor is known then it is possible to assume the radiation on the tilted surface for solar hot water system. The ratio of the beam radiation falling on a tilted surface to that falling on a horizontal surface is called the tilt factor  $r_b$  for beam radiation. For the case of a tilted surface facing south in the northern hemisphere,  $r_b$  is given by [19]

$$r_b = \frac{\cos\theta}{\cos\theta_z} = \frac{\sin\delta \sin(\phi - \beta) + \cos\delta \cos\phi \cos(\phi - \beta) \cos\omega}{\sin\delta \sin\phi + \cos\delta \cos\phi \cos\omega} \quad (3)$$

where  $\theta$  = the angle between the beam radiation on a surface and normal to that surface,  $\theta_z$  = the zenith angle,  $\phi$  = the latitude,  $\beta$  = the tilt angle,  $\delta$  = the declination for the average day of each month,  $\omega$  = the hour angle for the tilted surface for the average

day of the month. The tilt factor  $r_d$  for diffuse radiation is the ratio of the diffuse radiation falling on the tilted surface to that of the falling on the horizontal surface. It depends on the distribution of diffuse radiation over the sky and on the portion sky dome seen by tilted surface. We assume that the sky is isotropic source of diffuse radiation [19].

$$r_d = \frac{1 + \cos\beta}{2} \quad (4)$$

We assume that the reflection of the beam and diffuse radiations falling on the ground is diffused and isotropic and that the reflectivity is  $\rho$ , the tilt factor for reflected radiation is given by [19]

$$r_r = \rho \frac{1 - \cos\beta}{2} \quad (5)$$

Where  $\rho$  = the surface albedo.

The monthly surface albedo values are known from NASA and it lies between 0.12 and 0.16. The total radiation on a tilted surface of the collector will be the sum of direct diffuse and reflected radiation. It is expressed by [19]

$$I_T = I_b r_b + I_d r_d + (I_b + I_d) I_r \quad (6)$$

Where  $I_b$ ,  $I_d$  and  $I_r$  are the instantaneous values of beam, diffuse and direct radiations respectively. Thus the hourly tilt factor (see Table VII),  $R$  can be given by [19].

$$R = \frac{I_T}{I_H} = \left(1 - \frac{I_d}{I_H}\right) r_b + \frac{I_d}{I_H} r_d + I_r \quad (7)$$

Or using other notations [20],

$$R = \frac{H_T}{H} = \left(1 - \frac{H_d}{H}\right) R_b + \frac{H_d}{H} R_d + R_r \quad (8)$$

The tilt angles are chosen in such a way so that solar hot system should get significant solar radiation. In summer, the sun's path is shorter and it shines in the zenith at noon and in winter the sun's path is longer and the path is closer to horizontal at noon. During summer, if we keep solar device horizontally it will get more sunlight and during winter when it is tilted it will get more sunlight. In Bangladesh a study shows that if one simply changes the tilt angle at 40° for winter (October-February) and 10° for summer (March-September) then one can achieve higher tilt factors (see Table VIII).



**Table VII. Hourly tilt factors for latitude, tilted south facing surface at Dhaka [16]**

Hour Angle	±7.5	±22.5	±37.5	±52.5	±67.5	±82.5	±97.5
Jan	1.14	1.15	1.16	1.17	1.20	1.37	
Feb	1.12	1.12	1.12	1.13	1.14	1.21	
Mar	1.05	1.05	1.05	1.04	1.02	1.00	
Apr	0.99	0.99	0.98	0.97	0.95	0.93	0.95
May	0.96	0.96	0.95	0.93	0.91	0.89	0.97
Jun	0.95	0.95	0.94	0.92	0.90	0.88	0.78
Jul	0.95	0.95	0.94	0.92	0.89	0.86	0.76
Aug	0.97	0.97	0.96	0.95	0.93	0.89	0.82
Sep	1.00	1.00	1.00	0.99	0.98	0.96	0.70
Oct	1.06	1.07	1.08	1.08	1.08	1.13	
Nov	1.17	1.17	1.19	1.22	1.27	1.62	
Dec	1.19	1.21	1.23	1.26	1.36	1.53	

To estimate monthly average tilt factor Liu and Jordan proposed the following equation [20]

$$R = \overline{H_T} / \overline{H} = \left(1 - \overline{H_d} / \overline{H}\right) R_b + \left(\overline{H_d} / \overline{H}\right) \left[ \left(1 + \cos \beta\right) / 2 + \pi(1 - \cos \beta) / 2 \right] \quad (9)$$

**Table VIII. Hourly tilt factors for 10 and 40 degree combination south facing tilted surface at Dhaka [16]**

Hour Angle	±7.5	±22.5	±37.5	±52.5	±67.5	±82.5	±97.5
Jan	1.16	1.17	1.19	1.21	1.26	1.54	
Feb	1.12	1.12	1.13	1.14	1.17	1.29	
Mar	1.04	1.04	1.03	1.03	1.02	1.01	
Apr	1.01	1.01	1.01	1.00	0.99	0.98	0.99
May	1.00	1.00	0.99	0.98	0.97	0.96	1.00
Jun	0.99	0.99	0.99	0.98	0.97	0.96	0.92
Jul	0.99	0.99	0.99	0.98	0.97	0.95	0.91
Aug	1.00	1.00	1.00	0.99	0.98	0.97	0.93
Sep	1.01	1.01	1.01	1.01	1.00	0.99	0.88
Oct	1.04	1.04	1.06	1.07	1.07	1.16	
Nov	1.19	1.20	1.24	1.28	1.38	1.93	
Dec	1.24	1.26	1.29	1.36	1.52	1.79	

For a south facing surface [20]

$$\overline{R_b} = \frac{\overline{H_{bT}}}{\overline{H_b}} = \frac{\cos \delta (\Theta - \beta) \cos \delta \sin \omega'_s + (\pi/180) \omega'_s \sin(\Theta - \beta) \sin \delta}{\cos \delta \cos \delta \sin \omega_s + (\pi/180) \omega_s \sin \Theta \sin \delta} \quad (10)$$

$\omega'_s$  = the sunset hour angle for the tilted surface for the average day of the month

$\omega'_s$  = the sunset hour angle

$$\omega'_s = \min [\cos^{-1}(\tan \Theta \tan \delta), \cos^{-1}(-\tan(\Theta - \beta) \tan \delta)] \quad (11)$$

“min” means the smaller of the two items in the bracket.

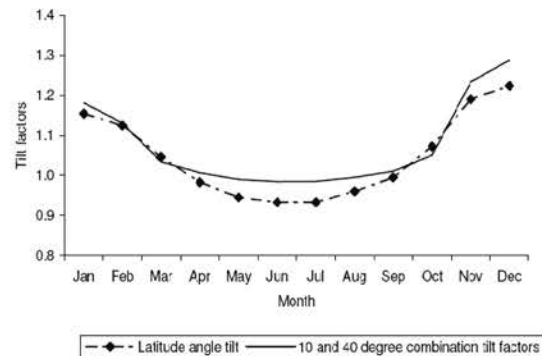

**Fig 8. Monthly tilt factors for Dhaka [16]**

From Fig. 8 it is clear that the total radiation will decrease if one keeps the surface at latitude tilt angle in summer season at Dhaka. To get higher values from the solar system one may practice tilting the surface, two times over the year at above tilt angles.

**Conclusion**

The automated controller, developed by CARC, has proven so far to be risk free and user friendly and the whole system requires only a one-time investment. Not only will it cater to users of hot water but also greatly contribute in toning down the huge demand on electricity from the national grid and other sources. Natural resources tend to deplete in the long run and it is truly high time solutions be found by utilizing renewable and alternative sources of energy. This endeavor was nothing short of reaching that goal. It is needless to mention that the system can be used for both domestic and industrial purposes regardless of the components used in building it and the system is capable providing uninterrupted hot water in an efficient manner. Using aluminum foil and cork sheet it was found the temperature drop overnight is 6 degree Celsius in winter. Analysis of the insulator materials reveals that rock wool is the optimum choice for insulation which could lead to further decrease in heat loss. The optimum angle is at 40



degrees for winter (October-February) and 10 degree for summer (March-September). In average the optimum angle is around 22-25 degree Celsius. This variation in angle could be the reason for one of few shortcomings of this system presently. In the future, the system can have additions like fully automated tilting process for maximum sunlight exposure.

#### Acknowledgement

We would like to acknowledge BRAC University for funding this project from the allocated research fund. Our special thanks to all members of SHWS (Solar Hot Water System) project team for their invaluable contribution to the successful implementation of the project at BRAC university premises.

#### References

1. Jannatul Ferdous, Md Sanzidul Islam, Nabil Shaker, Bonny Amin Khan, A. Azad, "Performance Improvement of SHWS by Increasing Thermal Efficiency Using Insulation Materials and Optimum Position of Solar Collectors" published in International Journal of Advance Renewable Energy Research, 2012, Vol.: 1, Issue: 1, Pages: 78 - 83, IJARER, Germany.
2. J. Ferdous, M. S. Islam, N. Shaker, B. A. Khan and A. Azad, "Performance improvement of SHWS by increasing thermal efficiency using insulation materials and optimum position of solar collectors" Proceedings of the 2nd IEEE International Conference on the Developments in Renewable Energy Technology, Bangladesh, January 2012.
3. M. R. Hasan, A. Rahman and A. Azad, "Feasibility and Importance of an Automatic Controller for Solar Hot Water System" Proceedings of IEEE Global Humanitarian Technology Conference (GHTC 2011) - Technology for the Benefit of Humanity, October 30 - November 1, 2011, Seattle, Washington, USA.
4. M. R. Hasan, K. Arifin, A. Rahman, A. Azad, "Design, implementation and performance of a controller for uninterruptible solar hot water system" Proceedings of IEEE 18th International Conference on Industrial Engineering and Engineering Management (IE&EM), China, September 2011.
5. M. K. Arefin, M. R. Hasan and A. Azad, "Characteristics and Cost Analysis of an Automatic Solar Hot Water System in Bangladesh" Proceedings of 2nd IEEE International Conference on Environmental Science and Technology, ICEST 2011, Singapore, February 26-28, 2011.
6. S. Sadrin, M. Hassain, E. Mohith and A. M. Azad, "Alternative solar water heater for domestic purpose", 2010.
7. Yu Gui Yin, "Design and implementation of solar water heater Intelligent control system", "International conference on energy and environment technology, 2009.
8. Andy Szatkowski, William Pruehsner, John D. Enderle Ph.D., "Water Temperature Control System", 0-7803-5486-9/99/\$10.00 @ 1999 IEEE.
9. Zhang Hua, Cai Zhenjiang, Li Yan," Fuzzy control strategies for temperature of hot-water based on PLC system ", 978-1-4244-8217-7110/\$26.00 ©2010 IEEE.
10. Zhao Futao Du Wei XuYiheng Hu Zhiren," Programmable Logic Controller Applied in Steam Generators Water Levels ", 0-7803-3544-919\$65 .000 1996 IEEE.
11. Man Gyun Na," Auto-Tuned PID Controller Using a Model Predictive Control Method for the Steam Generator Water Level", IEEE transactions on nuclear science, vol. 48, no. 5, october 2001.
12. KarstenSpreitzer, DorteRiickbrodt, Harald-Straky, "Observer-based estimation of the water-mass-flow through a central heating boiler", Proceedings of the American Control Conference Anchorage, AK May 8-1 0,2002.
13. Zhiliang Ding, Changde Wang, Guangming Tan, Guanghua Guan," The application of the fuzzy self-adaptive PID controller to the automatic operation control of water transfer canal system", 2009 Second International Conference on Intelligent Computation Technology and Automation.
14. Zhao Xueliang, Shi Yun, FengCangxu," The groundwater layered automatic monitoring system based on MSC1210", 2010 International Conference on Computer and Communication Technologies in Agriculture Engineering.

15. Kerkeni, C.; BenJemaa, F.; Kooli, S.; Farhat, A.; Belghith, A.; "Solar domestic hot water: numerical and experimental study of the thermal stratification in a storage tank," IEEE conf, Environment and Solar, 2000 Mediterranean, Beirut, Lebanon.
16. Final Report of Solar and Wind Energy Resource Assessment (SWERA) – Bangladesh Project Supported by-United Nations Environment Programme (UNEP), Global Environment Facility (GEF).
17. M. R. Islam, T.H.M.S. Rashid, "Prospects and Potential Analysis of Solar and Biomass Energy at Pabna District, Bangladesh: A Realistic Way to Mitigate District Energy Demand", published in International Journal of Engineering and Advanced Technology (IJEAT), 2012, Vol.: 2, Issue: 2.
18. A. Szatkowski, W. Pruehsner, and J. D. Enderle, "Water temperature control system for patients with reduced sensory and motor capabilities.," Bioengineering Conference, 1999. Proceedings of the IEEE 25th Annual Northeast , vol., no., pp. 39, 40, 8-9 Apr 1999 doi: 10.1109/NEBC.1999.755750.
19. C. S. Solanki, "Solar Radiation" in Solar Photovoltaics: Fundamentals, Technologies and Applications, Prentice Hall, 2011, ISBN-10: 8120343867 pp. 319.
20. A. Woyte, "Grid Connection of Photovoltaic Systems" Ph.D. dissertation, Dept. Elect. Eng., University of Leuven, Leuven, Flanders, Belgium, 2003.