

An Investigation of a Grid-Connected Solar Powered Water Pumping System

Mohammed Shadman Salam
I.D: 11315003

Internship report submitted in partial fulfilment of the requirements
for the degree of Bachelor of Science (BS) in Applied Physics and
Electronics



I n s p i r i n g E x c e l l e n c e

Department of Mathematics and Natural Sciences
BRAC University
Dhaka, Bangladesh
February 2016

Declaration

I hereby declare that the internship report titled "An Investigation of a Grid-Connected Solar Powered Water Pumping System" is submitted to the Department of Mathematics and Natural Sciences of BRAC University as a part of the requirements for the degree of Bachelor of Science (BS) in Applied Physics and Electronics. The presented work is a product of my own research and has not been submitted elsewhere for any other degree or diploma. All related research work that has been used as reference for this work has been properly cited.

Candidate

Mohammed Shadman Salam

ID:11315003

Certified by

Dr. M. Shamim Kaiser

Associate Professor

Institute of Information Technology

Jahangirnagar University

Acknowledgements

I am sincerely grateful to Dr. M. Shamim Kaiser for providing me with the opportunity to carry out the research project on solar powered water pumping technology that is being carried out in Jahangirnagar University, Savar, Dhaka. Without his continued guidance throughout the period of my internship and his availability whenever I sought his assistance, the internship project would not have been possible.

I would also like to convey my sincere gratitude to the Chairperson of the Department of Mathematics and Natural Sciences, Prof. A. A. Ziauddin Ahmad, for his lasting support and availability whenever I knocked on his door for a word. Furthermore, I am grateful to every faculty member in the department and specially would like to highlight the importance of Dr. Md. Firoze H. Haque, Mr. Muhammad Lutfor Rahman, Mr. Mahabobe Shobahani, Ms Fardousi Ara Begum and the Late Prof. Mofiz Uddin Ahmed in the last four years of my undergraduate life at BRACU.

Abstract

The following research work highlights the working principles of a solar powered water pumping system and how it can be a viable option in the context of Bangladesh. The report intends to differentiate between two types of solar powered systems namely, Stand-alone systems and Grid-Connected Systems, and come to a conclusion as to which is more feasible to satisfy the water requirements for irrigation in rural areas. The conclusion is supported by means of data collected and evaluated using the facilities at Jahangirnagar University and some international sources. Finally, the examined data set is presented in the form of tables and graphs to further shed light on the prospect of solar powered technology.

Contents

1	Introduction	7
2	Types of Solar Powered Water Pumping Systems	9
2.1	Stand-alone Systems	9
2.2	Grid-Connected Systems	9
2.3	Advantages and Disadvantages of Grid-Connected P-V Systems	10
2.4	Grid-Connected System Over Stand-alone Systems	10
3	Grid-Connected System Model and Working Principle	12
4	Project Undertaken at Jahangirnagar University	14
5	Results	17
5.1	Analysis 1	17
5.2	Analysis 2	17
6	Conclusion	20

List of Figures

3.1	System Model	12
4.1	Model of Grid-Connected P-V System Being Used at Jahangir-nagar University	14
4.2	PV Array Side View	15
4.3	Solar Power Detector and Analyzer	16
5.1	Monthly Sunshine Duration	18
5.2	Monthly average Energy Generation	19

List of Tables

5.1	Average Output Power Per Day	17
5.2	Sunshine Duration and Monthly Energy Generation	18

Chapter 1

Introduction

Solar power is becoming an increasingly important source of power for various electrical equipment that will ease the burden on fast running out non-renewable energy sources. Among a lot of other applications of solar power technology, it can play a vital role in water pumping systems, which is the focus of this report.

In employing solar power as the main energy source for pumping water, burden on diesel used in generators can be greatly reduced which is not only cost effective, considering the one time investment in solar panel, but also is environmentally friendly which is becoming a major concern in today's world. Furthermore, the lack of need of fuel to sustain solar powered pumps and also the minimal maintenance that it requires makes solar power technology vital in accessing water in remote, rural areas. More importantly, solar powered water pumping system is very effective on a very hot and sunny day because availability of water is imperative under these circumstances; more the solar energy available, the more is pumped. All these factors collectively help to provide and maintain a decent water supply to off-grid areas so that irrigation of land is not interrupted due to dry weather and hence serves in the betterment of rural life as a whole [3].

Although a solar powered water pumping system serves its primary objective of ensuring the accessibility of water in remote areas, this system has its limitations. For starters, a good amount of capital investment is required which may not be forthcoming. Furthermore, whenever the conditions are not suitable- cool, cloudy days- the efficiency of the system suffers. Hence,

a separate water storage tank is required to be filled in preparation for such days which is another source of expenditure. Also, in remote, off-grid areas, the number of skilled technicians capable of repairing a solar powered system may be very low, putting the feasibility of the whole system under scrutiny [3].

Chapter 2

Types of Solar Powered Water Pumping Systems

2.1 Stand-alone Systems

Stand-alone systems are systems that are not connected to the utility grid, but operate separately. Direct coupled systems are the simplest form of stand-alone system, where the photo-voltaic (P-V) array is directly connected to the load and thus can only function when the sun is shining. They do not have any battery backup and are mainly designed to supply DC or AC loads. This type of system is suitable for operating application like ventilation fans and water pumps.

In many stand-alone P-V systems, batteries are used for storing energy. This is done so that, even when the sun is not shining it can operate for a certain period of time depending on consumption by the user [5].

2.2 Grid-Connected Systems

Grid-connected systems are those that are connected to the grid and are designed to operate in parallel with the grid. In this type of system an inverter is used to convert the DC output produced by the P-V array into AC so that it matches the grid requirements, i.e voltage, power and frequency. Because the grid-connected systems are connected to the grid, when the grid goes down the system also shuts down. Whenever there is a shortage of

power, the system borrows from the grid in order to operate and when there is a surplus of electrical power generation it supplies this extra power to the grid [4].

2.3 Advantages and Disadvantages of Grid-Connected P-V Systems

Among a number of advantages of the grid-connected P-V system, firstly it reduces the need for fossil fuel, which reduces the emission of greenhouse gases, thus reducing pollution. Furthermore, they are convenient to install and can be installed on any scale from running a simple household to operating a large scale business. Also, they can be fitted anywhere, even on rooftops. Moreover, the grid-connected P-V system is the least expensive of all other systems and requires the least maintenance, mainly because they consist of no batteries. In short, the electrical grid becomes the sole power supply [2].

However, they do have some disadvantages. As grid-connected systems are connected to the grid, when the grid goes down due to any technical difficulty the system automatically goes down, which means that the output obtained by the P-V array cannot be used for any other purpose. No matter how brightly the sun is shining, the power obtained becomes useless [2].

2.4 Grid-Connected System Over Stand-alone Systems

A stand-alone P-V system, as explained above, is not tied to the grid and requires a battery to operate and to store electricity. These batteries are very expensive and need to be changed over a period of time. For a stand-alone system, when the weather is cloudy for a long period of time, the system shuts down causing a power failure for the household or the business where it is being used. On the other hand, using a grid connected P-V system ensures that even if there is little sunlight for a couple of days, there will not be a power failure. The extra power needed when the P-V system is incapable of producing the required amount will be taken from the grid and

when it produces in excess the extra power will be supplied to the grid, thus ensuring a balance in input and output power. This process of exchange also helps reduce shortage of electricity during peak hours [4].

In the context of Bangladesh it is more advantageous to use grid-connected P-V system. This is so because there is a shortage in production of electricity by the national grid, resulting in a shortage of electricity all over the country. If the number of grid-connected P-V systems increases then the current crisis of electricity shall be reduced [1].

Chapter 3

Grid-Connected System Model and Working Principle

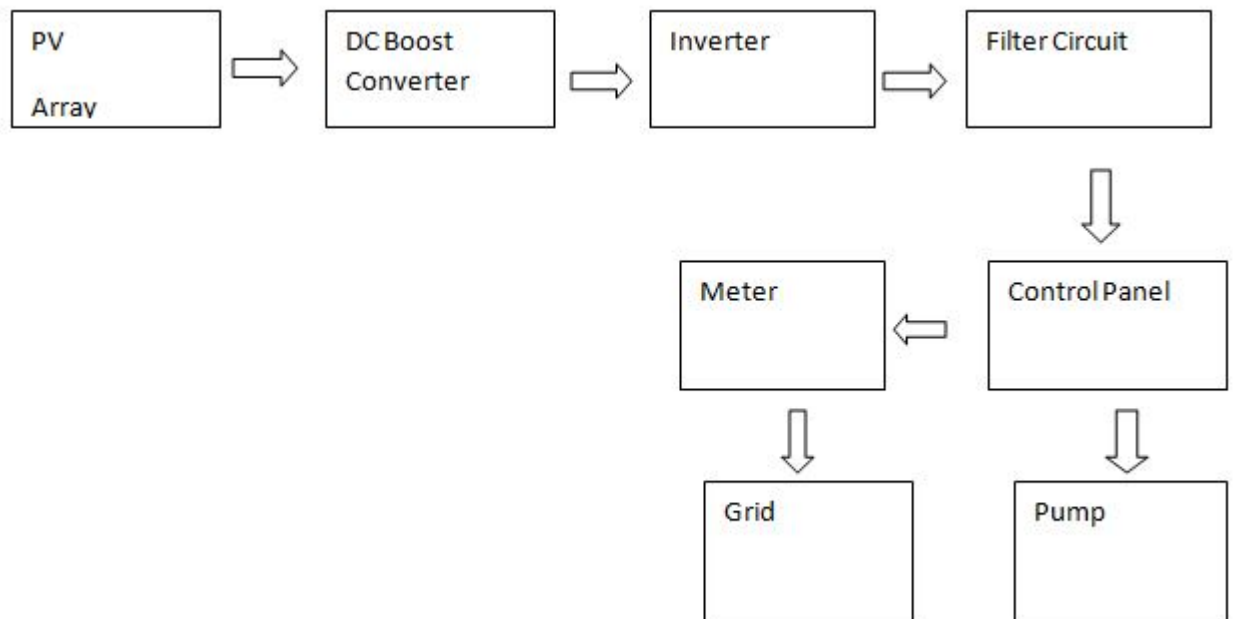

Figure 3.1: System Model

The P-V array produces DC electricity which flows through the boost converter and gets amplified by a factor of m and then goes into the in-

verter, which converts the DC electricity to AC electricity which must be grid-compatible. Inverters in these systems are referred to as “synchronous” inverters, because they produce electricity in synchronization with the grid.

The converted AC voltage from the inverter then flows through the main service panel and then to the loads. If the electricity produced is less than what is required to run the load, the extra electricity required is borrowed from the grid. And if the electricity produced is more than that is required, it is supplied to the grid. In between this exchange the electricity passes through a meter that records how much electricity is supplied to or taken from the grid.

Chapter 4

Project Undertaken at Jahangirnagar University

The model for the solar powered water pumping system that is set up at Jahangirnagar University, Savar, is similar to the model shown in the figure below. If the temperature of the solar pump is higher than some threshold temperature, the micro-controller circuit switches the pump off. Also, the micro-controller will switch on and off the pump based on a preset time. When the load energy is zero during a sunny day, the surplus energy will be fed to the national grid and on a cloudy day, pump will take energy from the national grid to meet the demand.

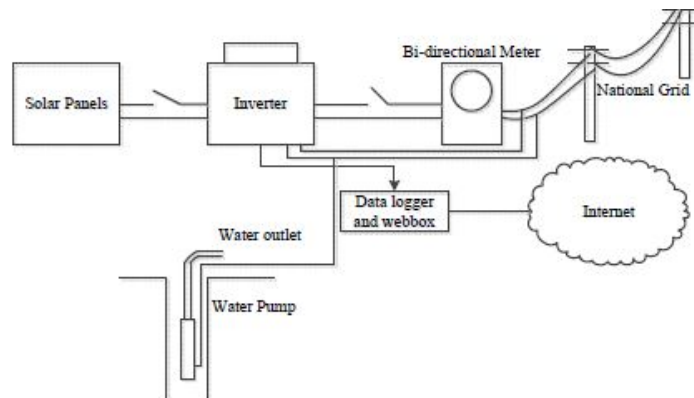

Figure 4.1: Model of Grid-Connected P-V System Being Used at Jahangirnagar University

The solar panel being used is shown below:



Figure 4.2: PV Array Side View

The PV array consists of sixteen modules connected in series. Each solar panel has 60 cells in them and is capable of producing a maximum power of 4kWh per hour.

The solar panel specification are as follows:

Rated max power : 260 W

Open Circuit voltage : 38.9 V

Rated Voltage : 30.7 V

Short Circuit Current : 9.18 A

Rated Current : 8.56 A

Series Fuse : 16 A

The detected radiation energy is then analyzed and displayed using the meters depicted in the figure below. These meters are capable of displaying the solar energy at specified time intervals (in our case it was 15 minutes) along with the generated power. The operating voltage of the solar panel in use is 4.2kW and on a bright sunny day it is capable of generating a power close to its maximum capacity of 260W.



Figure 4.3: Solar Power Detector and Analyzer

The project consisted of noting down the data from the detected radiation at regular time intervals for a period of eight days. The present work focused on finding out a relation between sunshine duration and monthly power generation. For this part of the work, data provided by NASA were used in the analysis and the result section elucidates on it.

Chapter 5

Results

5.1 Analysis 1

The values obtained over an eight day period of data collection of the reception of solar power and generation of the water pumping energy are tabulated as follows.

Table 5.1: Average Output Power Per Day

Day	Average Output Power per day (W)
1	2592
2	1697
3	2836
4	2158
5	2655
6	1663
7	1265
8	2598

5.2 Analysis 2

The table below gives the monthly average energy generation by a grid-connected P-V system. The sunshine duration recorded over Bangladesh each month in 2015 is taken from NASA's website (link provided in bibliography),

with the energy capacity of the system being 4.2kW and the subsequent daily and monthly energy values are found empirically.

Table 5.2: Sunshine Duration and Monthly Energy Generation

Month	Sunshine Duration (hr)	Estimated Capacity of System (kW)	Energy Generation per Day (kWh)	Monthly average Energy Generation (kWh)
1	7	4.2	29.4	911.4
2	7.8	4.2	32.76	917.28
3	7.8	4.2	32.76	1015.56
4	7.8	4.2	32.76	982.8
5	6.9	4.2	28.98	898.38
6	4.1	4.2	17.22	516.6
7	3.8	4.2	15.96	494.76
8	4.5	4.2	18.9	585.9
9	4.8	4.2	20.16	604.8
10	6.8	4.2	28.56	885.36
11	7.3	4.2	30.66	919.8
12	7.1	4.2	29.82	924.42

A graph of the data given above was plotted for each month and is given below.

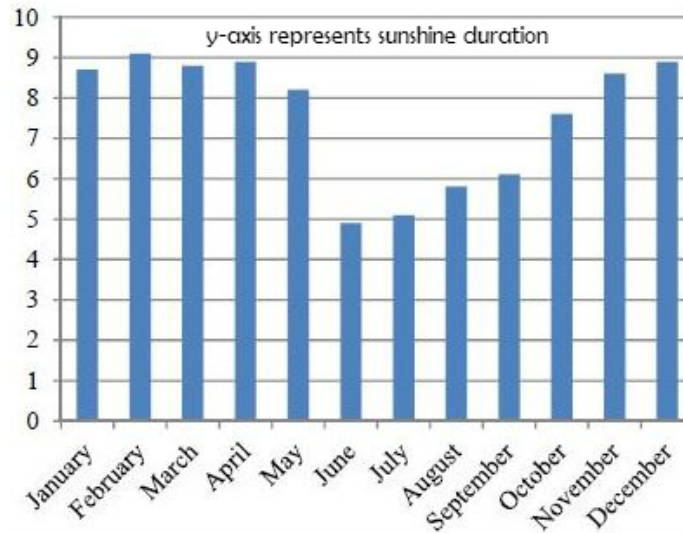

Figure 5.1: Monthly Sunshine Duration

Furthermore, monthly average energy generation can also be shown on a bar graph with respect to each month

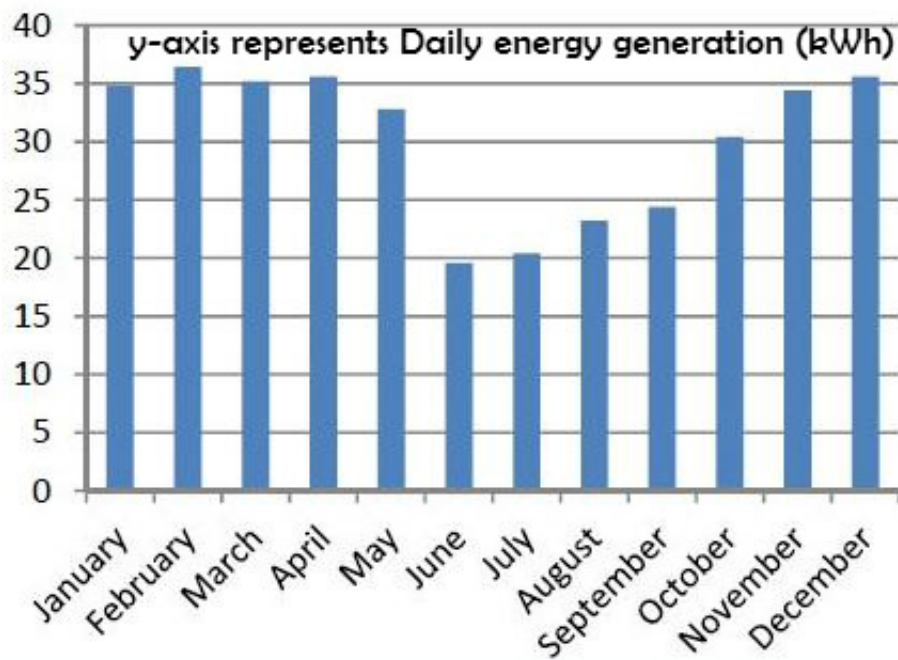

Figure 5.2: Monthly average Energy Generation

Chapter 6

Conclusion

Solar water pumping system is reliable and long lasting. It requires minimum maintenance. Though it is expensive to install but in the long run it is relatively cost effective. As a developing country, Bangladesh needs these system so that we can have lower maintenance cost and can have water for irrigation and other purposes. With increasing reliance on natural gas and fossil fuels, we run the risk of exhausting them in the near future. Our region is subject to a healthy amount of sunshine as the results show, which makes it very important for us to take initiatives and improve on solar powered technology.

Bibliography

- [1] Deb, A. , *et. al* (2013) *Prospects of Solar Energy in Bangladesh*
<http://www.iosrjournals.org/iosr-jeee/Papers/Vol4-issue5/H0454657.pdf>
- [2] Jenkins, T. (no date) *Designing Solar Water Pumping System for Livestock*
- [3] Noble, N. (2012) *Solar (Photovoltaic) Water Pumping*
https://wiki.umn.edu/pub/EWB/Uganda_Groundwater_Supply/solar_water_pumping.pdf
- [4] Ratterman, W. , *et. al* (2007) *Solar Water Pumping Systems Introductory and Feasibility Guide*
http://www.riaed.net/IMG/pdf/Solar_pumping_systems_Guide_2007.pdf
- [5] Waterman, B. (2013) *Solar Water Pumping Basics*
https://www.uvm.edu/vtvegandberry/Pubs/Solar_Water_Pumping.pdf