

Electronic Toll Collection System Using RFID Technology

**A Thesis Submitted in Partial Fulfillment of the
Requirements for the Degree of
Bachelor of Science in Electrical and Electronic Engineering**

By

Kazi Jubidur Rahman -12121144

Mustafa Mahmud Hasan-12121145

Nowshin Ahmed-12121141

Rawshan Zaman-11221007

Supervised by

Ms. Marzia Alam

Senior Lecturer

Department of Electrical and Electronic Engineering

BRAC University, Dhaka.



Inspiring Excellence

Fall 2016

BRAC University, Dhaka

DECLARATION

We hereby declare that, the thesis titled “Electronic toll collection system using RFID technology” is our work. The work has not been presented elsewhere for assessment. Where material has been used from other sources it has been properly acknowledged.

Signature of Author

.....

Kazi Jubidur Rahman

Student ID: 12121144

.....

Mustafa Mahmud Hasan

Student ID: 12121145

.....

Nowshin Ahmed

Student ID: 12121141

.....

Rawshan Zaman

Student ID: 11221007

Signature of Supervisor

.....

Ms. Marzia Alam

Department of Electrical and Electronic Engineering

BRAC University

ACKNOWLEDGEMENTS

Firstly, We would like to thank Ms Marzia Alam, Senior Lecturer, Department of Electrical and Electronic Engineering (EEE), BRAC University; for his supportive guidance and feedbacks for completion of the thesis. Secondly, our gratitude is towards BRAC University for funding this project.

ABSTRACT

In this thesis we will discuss RFID based Smart Toll Collection System as a solution to solve the traffic problems and also to maintain transparency of the toll collection system. Our aim is to make a digital toll collection system which will be less time consuming and automated. This project focuses on an electronic toll collection (ETC) system using radio frequency identification (RFID) technology. The proposed RFID system uses tags that are mounted on the windshields of vehicles, through which information embedded on the tags are read by RFID readers; the proposed system eliminates the need for vehicle owners and toll authorities to manually perform ticket payments and toll fee collections, respectively. Data information are also easily exchanged between the vehicle owners and toll authorities, thereby enabling a more efficient toll collection by reducing traffic and eliminating possible human errors.

In addition, in this project we will measure weight of the vehicles using a weight sensor. Over weight transport will be blocked, they will not get access. In calculation, Economical analysis of the automatic toll collection system is also presented and is compared with the manual ticketing base system.

CONTENTS

Acknowledgement.....	2
Abstract.....	3
List of Figures.....	7
List of Tables.....	9
Abbreviations.....	10
Chapter 1: Introduction.....	11
1.1. Introduction to development of electronic toll plaza.....	11
1.2. Problems with the Traditional toll collection system.....	13
1.3. Advantages of Electronic toll collection system.....	14
1.3.1. Increased Capacity.....	14
1.3.2. Fuel saving.....	14
1.3.3. Operating cost saving.....	14
1.4. Motivation and Objectives.....	15
1.4.1. Motivation.....	15
1.4.2. Objectives.....	15
1.5. Background of our project.....	15
1.6. Different Types of Electronic Toll Collection System.....	17
1.6.1. Barcode-based Electronic Toll Collection System.....	17
1.6.2. ANPR (Automatic Number Plate Reader).....	18
1.6.3. Calm active infrared.....	19
1.6.4. VPS-technique (Vehicle Positioning System).....	19
1.6.5. RFID-based Electronic Toll Collection System.....	20

1.7. Summary of our project.....	21
Chapter 2: Project Overview.....	22
2.1. Application area of the project.....	22
2.2. Comparison between proposed and existing toll system.....	23
2.3. Working principle of our project.....	25
2.4. Toll payment limitations.....	26
2.4.1. Sufficient amount in account.....	27
2.4.2. Insufficient amount in account.....	27
Chapter 3: Hardware and Software Components.....	28
3.1. Introduction.....	28
3.2. Hardware components.....	28
3.2.1. Arduino Mega R3 2560.....	29
3.2.2. Load Cell 5kg.....	30
3.2.3. HX-711 Load Cell Amplifier.....	30
3.2.4. RC-522 13.56 MHz RFID Reader.....	32
3.2.5. Servo SG-91.....	34
3.2.6. LCD Display (16*2).....	34
3.2.7. SIM900A kit.....	36
3.2.8. GSM Module.....	37
3.3. Software Components.....	38
3.3.1. Arduino IDE.....	38
3.3.2. Python.....	39
Chapter 4:Proto type Mechanism and Algorithm.....	40
4.1. System Design.....	40
4.2. Algorithm.....	45

4.3. Working procedure of proto type.....	46
4.4. Display results.....	46
4.5. Computer Display.....	51
Chapter 5: Economic Overview.....	54
5.1. Present Toll Collection System Economic losses.....	54
5.2. Proposed Toll System Economic Benefits.....	55
5.3. Equations for Data Analysis.....	56
5.4. Data Analysis and Results.....	58
Chapter 6: Plan and Budget.....	62
6.1. Plan for Proto Type.....	62
6.1.1. Time Line of Proto Type.....	62
6.1.2. Budge for Proto Type.....	63
6.2. Plan for original Type.....	63
6.2.1. Time Line of Original Type.....	63
6.2.2. Budget for Original Type.....	64
Chapter 7: Conclusion and Future Ideas.....	65
7.1. Conclusion.....	65
7.2. Future Ideas.....	65
REFERENCES.....	67
APPENDIX.....	68
APPENDIX A.....	68
APPENDIX B.....	84

LIST OF FIGURES

1.1. Figure: Digital toll plaza.....	12
1.1.1. Figure: huge traffic jam in front of a traditional toll plaza in our country.....	12
1.2. Figure: A manual toll plaza of Bangladesh.....	13
1.6.1. Figure: DSRC system for electronic tolling.....	18
1.6.2. Figure: IVU (In-vehicle unit).....	19
1.6.5. Figure: RFID technology for Electronic Toll Collection.....	20
1.7. Figure: digital toll collecting system.....	21
2.1. Figure: Proposed area, Meghna Bridge Toll booth.....	22
2.2. Figure: Manual toll collection system.....	23
2.2.1. Figure: Waiting in queue for toll payment.....	24
2.2.2. Figure: Toxic gas coming out from vehicles.....	24
2.3.1. Figure: ETC toll collection system.....	26
3.2.1. Figure: Arduino Mega R3 2560.....	29
3.2.2. Figure: Load Cell 5kg.....	30
3.2.3. Figure: HX-711 load cell amplifier.....	31
3.2.4. Figure: RC-522 13.56 Mhz RFID Reader.....	32
3.2.4.1. Figure: RC-522 13.56 Mhz RFID Reader flow chart.....	33
3.2.5. Figure: Servo SG-91.....	34
3.2.6. Figure: LCD Display (16*2).....	35
3.2.7. Figure: SIM900A kit.....	37
3.2.8. Figure: GSM Module working flow chart.....	37
3.2.8.1. Figure: GSM Module.....	38

4.1. Figure: Mechanism instrument settings.....	41
4.1.1. Figure: Our System outlook.....	42
4.1.2. Figure: RFID setup with Arduino.....	43
4.1.3. Figure: SMS sending in mobile phone using GSM module.....	44
4.4. Figure: SMS Screen shot	47
4.4.1. Figure: SMS showing the transport cannot pass because of insufficient balance.....	48
4.4.2. Figure: SMS showing the transport has insufficient balance, so it has to pay manually. After paying manually the transport can pass.....	48
4.4.3. Figure: toll collected from a bus.....	49
4.4.4. Figure: Toll collected from a car.....	49
4.4.5. Figure: SMS showing the transport cannot pass because of overweight.....	50
4.4.6. Figure: Toll collected from another car.....	50
4.5. Figure: display showing the manually collected toll.....	51
4.5.1. Figure: display showing the data of toll collection from a bus.....	52
4.5.2. Figure: display showing the data of toll collection of a car.....	52
4.5.3. Figure: result showing in Python.....	53
4.5.4. Figure: Result displaying in a notepad (saved all data in total amount).....	53
5.1. Figure: Waiting for toll payment.....	54
5.1.1. Figure: Allowing vehicles without taking proper toll.....	55
5.2. Figure: Proposed toll collection system.....	56
5.4. Figure: Composition of various types of vehicle.....	61
5.4.1. Figure: Travel time output for manual and ETC system.....	61

LIST OF TABLES

Table 2.4: Different types of vehicle toll rate.....	27
Table 3.2.6.1: LCD Display (16*2) connection.....	36
Table 5.4: Fuel consumption.....	59
Table 5.4.1: Cost saving.....	59
Table 5.4.2: Total savings.....	59
Table 5.4.3: Per Year Savings in Taka.....	60
Table 6.1: Time line of proto type.....	63
Table 6.1.2: Proto type full cost.....	63
Table 6.2.1: Time line of original project.....	64
Table 6.2.2: Original project cost.....	64

ABBREVIATIONS

RFID: Radio Frequency Identification

MTC: Manual Toll Collection

ETC: Electronic Toll Collection

DSRC: Dedicated Short Range Communication

ANPR: Automatic Number Plate Reader

IVU: In-vehicle unit

VPS-technique: Vehicle Positioning System technique

LCD: Liquid Crystal Display

SIM: Subscriber Identity Module

GSM: Global System for Mobile

USB: Universal Serial Bus

RUC: Road User Costs

OECD: Organization for Economic Cooperation and Development

AADT: Annual Average Daily Traffic

Chapter 1

Introduction

1.1. Introduction to development of electronic toll plaza:

Now a day's traffic problem is a very severe problem in our country. In Bangladesh, every day we have to face traffic jam for several hours which is very annoying at the same time creating a huge trouble in our daily life. Traffic jam mainly causes for reckless driving and also for the rash of the vehicles in the road. For the reduction of traffic problem government has made many bridges, fly over's and bypass roads. People have to give toll when they pass these by any vehicle. Unfortunately, the toll collection system is manual in our country which takes many times to pass the vehicles and creating traffic jam. Here we introducing Electronic toll collection system using RFID technology which will be an automatic system, will not stop the vehicles as well as this system will help to reduce the traffic jam. Here, the payment will be taken from the bank account of the vehicle owner and he will receive a message from the server that the toll payment has been taken. In addition, our system will also help to solve the traffic severe crashes, which is mainly caused by over speeding as here we have used speed breaker to slow down the speed of the vehicles when RFID tag will read the information of the vehicles.

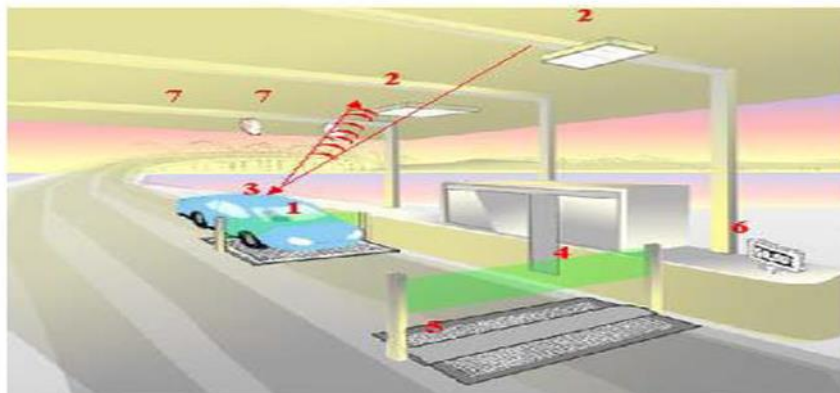



1.1. Figure: Digital toll plaza



1.1.1. Figure: huge traffic jam in front of a traditional toll plaza in our country

1.2. Problems with the Traditional toll collection system:

Traditional toll collection system or manual toll collection system is the simplest form of toll collection, in which a collector operating from a booth collects the toll. This method is slower and sometimes not perfect also. One or two persons sit in the toll collection booth and stop each vehicle to collect the toll manually. The collector gives a memo to the drivers as a record of toll payment. Moreover, in Bangladesh lots of corruptions are happening in this sector. There is no central controlling system for the toll collection, all the information regarding payments ad vehicles are not saving in a database or website. As a result corruption is happening and government is not getting all the toll money properly.

Problems:

- This system is slower
- Creates traffic jam as every vehicle has to stop
- Corruption is happening



1.2. Figure: A manual toll plaza of Bangladesh

1.3. Advantages of Electronic toll collection system:

Electronic toll collection system is a digital system of collection toll from vehicles without stopping them. Electronic Toll Collection lanes improve the speed and efficiency of traffic flow and save drivers' time. An Electronic toll collection system is capable of electronically charging a toll to an established customer account. The system can determine whether a passing car is registered, automatically charging those vehicles, and alert the local highway patrol about users that are not registered. The Electronic toll collection method allows vehicles to pass through a toll facility without requiring any action or stopping.

1.3.1. Increased Capacity:

Electronic Toll Collection System will increase the capacity of transport when passing the toll plaza as we will divide the road by four lane. Moreover our system is automate so our system will be increased the capacity of transport when passing the toll booth.

1.3.2. Fuel saving:

The deceleration, acceleration and idling is completely eliminated. This results in gas saving for the patrons using Electronic Toll Collection System. The elimination of acceleration and deceleration results in reduction of the operating cost of the vehicles.

1.3.3. Operating cost saving:

Over a period of time, the toll collecting cost is reduced. There is reduction in the man-hour required as the system does not require any human interaction for the toll transaction . Time saving ETC users do not stop for paying toll, thus there is considerable saving in the travel time. Besides the travel time reliability is increased as the travel time can be estimated fairly accurately.

1.4. Motivation and Objectives:

1.4.1. Motivation:

The motivation towards working on this project is to solve the traffic problems and also to maintain transparency of the toll collection system. Our aim is to make a digital toll collection system which will be less time consuming and automated. Moreover, Economical analysis of the automatic toll collection system I also presented and compared with the manual ticketing base system. In addition, we have also used weight sensor to measure the weight of the transports to maintain the health of the roads and bridges.

1.4.2. Objectives:

The objectives:

1. Introduce Electronic Toll Plaza in Bangladesh.
2. To compare various aspects of this existing system with the electronic toll collection system.
3. To find out the economic benefits of introducing Electronic Toll Collection.

1.5. Background of our project:

Transportation is the backbone of any country's economy. Advancement in transportation systems has created a lifestyle characterized by freedom of movement, trade in manufactured goods and services, high employment levels and social mobility. In fact, the economic wealth of a nation has been closely tied to efficient methods of transportation. Rapid development of the country especially in providing good infrastructure facilities to the people has constantly become an important agenda to the Government. To realize the Government's aspirations the Roads and Highways

Department of Bangladesh strives to guarantee modern, efficient, quality highway's that are attuned towards growth of the nation. Tolled highways were built looking at many factors, one of them being the heavy traffic and congestions around Meghna Bridge Toll Plaza. For many cases, tolled highways in major cities are basically roads that have been upgraded to highways. The situation becomes more complex when it involves a spectrum of local infrastructure that consists of housing areas, industries, factories and schools. The network of highways built, however, helps with the development of surrounding communities and defines the highways as the main route for local residents. The strategic location also encourages locals to use the highway more than once and here is where during peak hours toll plazas become as congested as normal roads.

Delay and queuing problems are most common in daily life situation, especially in traffic. Many roads and highways in Bangladesh have heavy traffic congestions due to driving convenience, such as delays and queuing problems at toll plazas. In effort to have this issue resolves as an innovative supervision committee, Roads and Highways Department encourages the use of modern technology.

Dhaka-Chittagong National highway is one of the busiest highways of Bangladesh. A huge volume of traffic moves everyday along this road between the capital city and the commercial capital of the country.

The vehicles moving through this route have to cross the Meghna Bridge and pay tolls at Meghna Toll Plaza. But due to delay in collection system, the users of this road normally have to face long queue. All the parties concerned are being negatively impacted by this delay. The passengers and the transport owners are to sacrifice the time while the toll collection authority is being deprived of getting more tolls within a stipulated time. According to a traffic survey in 2005, about 3584314 vehicles were recorded to cross Meghna Ghat toll plaza.

With passage of time, it is expected that more vehicle would be passing through the bridge and the problem of long queue would be increased. Introduction of an electric toll collection system may be one way to solve this problem. It would benefit all the parties concerned. The benefits of toll plaza can be broadly divided into three categories: benefits of toll agency, user benefits, and social benefits. The toll agency benefits include reduction in operating cost, reduction in man labor, reduction in maintenance cost, and enhanced cash handling. The user benefits include time saving due to the elimination of the hassle of digging for change and the elimination of acceleration and deceleration as the vehicles do not stop for toll transaction. [Ref.3]

1.6. Different Types of Electronic Toll

Collection System:

1.6.1. Barcode-based Electronic Toll

Collection System:

Barcode-based Electronic Toll Collection System is a sub category under DSRC. In this a bar-coded sticker is attached to the vehicle and read by a laser scanner when it passes through the toll plaza illustrates working of a typical DSRC system for electronic tolling. It is the simplest as well as oldest technology. It is used in various applications such as in library for managing book record, shopping plazas to take an account of sale and purchase, food industry to store food details and many more. Despite of all these it also has many drawbacks in order to be used for toll collection system such as lack of reliability, less accuracy in bad weather, lack of flexibility, slow data read rate, less storage information and easy to be theft.

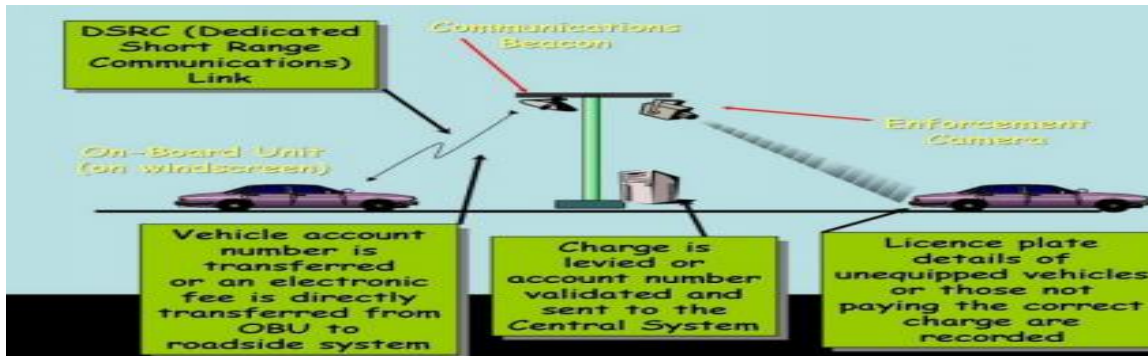

1.6.1. Figure: DSRC system for electronic tolling

1.6.2. ANPR (Automatic Number Plate Reader):

Another important technology is ANPR. It utilizes a stationary camera to record and identify the number plate of vehicles passing through toll plaza. The identified license numbers are matched in the database and toll is deducted. If the recorded number is not read properly or not found in the records, it issues an enforcement violation alarm to the alert the authorities. In this way, it simultaneously solves two objectives; identification of vehicle for deduction of toll tax and recording violation enforcement alert. The Indian government has started issuing —high security number plates. Thus this technology will also be helpful to detect the stolen vehicles and vehicles with fake number plates. It also has constraints of high cost and reduced accuracy under tempestuous environment conditions.



1.6.2. Figure: IVU (In-vehicle unit)

1.6.3. Calm active infrared:

Calm active infrared is a relatively new technology. It is similar to RFID system, the only difference is that it has an active infrared unit installed on vehicle which contains all the information. If we compare to RFID, it has a faster data reading rate, reliability, accuracy, efficiency and it works well in all environment conditions. It also comes over the problem of interference. Lack of interoperability, vendor support and high cost are the roadblocks in usage of this technology.

1.6.4. VPS-technique (Vehicle Positioning System):

Another one is VPS-technique consists of worldwide satellite navigation system incorporation with a communication mechanism. It works with the help of a global positioning system (GPS) unit installed on vehicle attached to an on board unit (OBU) , which stores the coordinates of the vehicle and send the transaction information to the toll authorities via GSM. This system is highly reliable, accurate and efficient. The efficiency of this system is not affected by environmental conditions. It provides a payment option only for the distance travelled and is highly flexible in generating the corresponding payment details. It can also be used by the police petrol for highway surveillance and theft prevention of automobile. The associated shortcomings for this system are its excessively high installation, running and maintenance cost, careful handling, requirement of extra power and other accessories. Present study has made it very clear that there are no clear trade-offs among the above mentioned technologies. Due to this, it becomes an onerous task to move further to decide the best option among the existing ones or to develop a newer technology. In such a state of ambiguity when one is not even able to choose the best among the existing alternative, there is no space for the question of adopting a hybrid technology. It also de-motivate the policy makers to adopt newer advanced technologies as a single wrong decision can bring up loads of problems for

coming generations with huge wastage of money and time. Therefore, it becomes essential to predict the best solution in terms of best alternative for such problems using a highly subjective decision making technique.

1.6.5. RFID-based Electronic Toll Collection System:

The best and easy technology is RFID-based Electronic Toll Collection System, which has an IVU (In-vehicle unit) installed on the front windshield of the vehicle. This IVU contains a cash card for payment of road tax. At toll plaza, this is read by the RFID frequency reader or antenna. It can be either prepaid or postpaid, with gate or without gate illustrates working of RFID-based Electronic Toll Collection System. It contains more information as compared to barcode, has faster reading rate, tough to be fraudulent and also comparatively more reliable. As the number of features increases we have to compromise with the cost, simplicity and ease to use. It is also observed that sometimes it show the problem of interference among frequency of devices (mobile phones, other IVU, walkie-talkies, FM radio or other electronic gadgets) in vicinity of the toll plaza or passing vehicles. Angle of installation and alignment plays an important role for reliability and high accuracy of these systems provides a brief idea about working mechanism of RFID-based ETC technology.

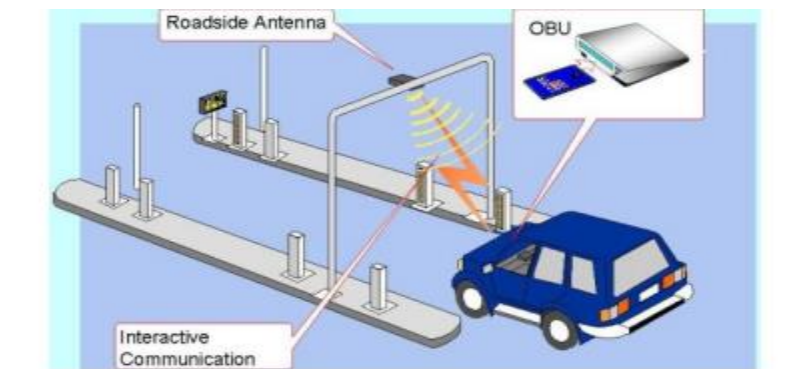

1.6.5. Figure: RFID technology for Electronic Toll Collection

1.7. Summary of our project:

Here we are trying to build a suitable computerized Toll Collection System with Manual Transaction would be selected. Secondary data on the traffic flow would be collected from the toll collectors. A primary survey would be conducted to observe the delay time, required acceleration and deceleration for various vehicles and time for transaction. An assessment of the existing system of the toll plaza would be made including the operating system being used, the efficiency of toll collection, problem faced by the toll collectors and the road users etc. An in depth analysis of the Electronic Toll Collection System would then be made. Various aspects of these two systems would then be compared and the benefit of introducing Electronic Toll Collection System would be found out in terms of saving in time, fuel and emission reduction.

In addition, here we will use weight sensor to measure the weight of the vehicles so that the roads, fly overs, bridges do not get damaged due to over weight of vehicles.

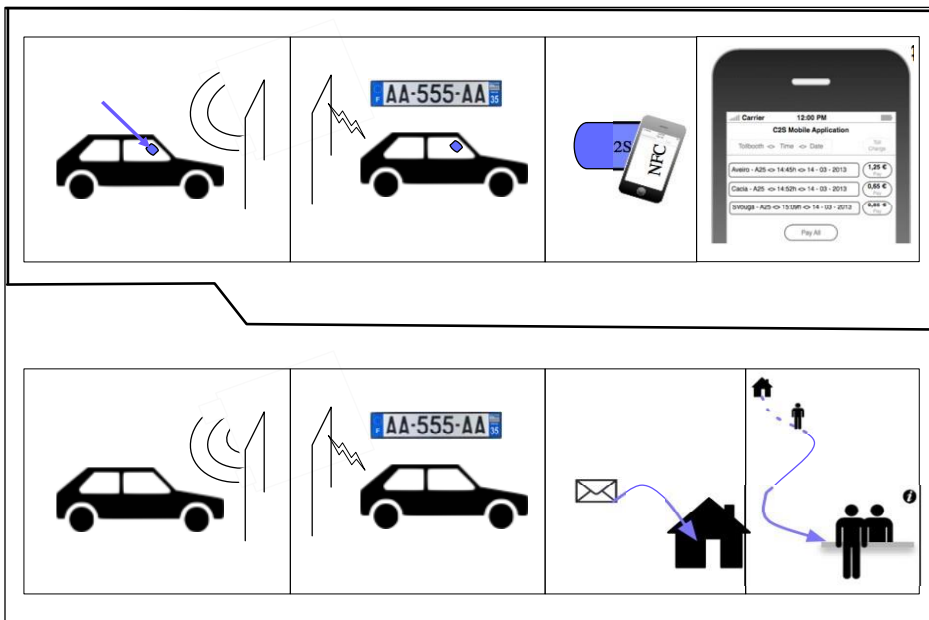

1.7. Figure: digital toll collecting system

Chapter 2

Project overview

2.1. Application area of the project

A country's drastic change happens when public needs not to waste their time in roads just because of huge traffic jam. Any country can only get rid of this jam issue by taking proper steps on utilizing the roads in better way. That is why our country government has taken different types of initiative to get rid of this jam issue. So government is making lots of bridge, flyover, under pass, u-loops etc. Some of this roads are government making by own costs and some are making by taking help of private sectors. When government makes roads in collaboration of private companies, they go for different kinds of deals and that time mainly toll collection is implemented to get back the invested money of private companies. In our country lots of bridges are done with a collaboration of private companies. Those are Meghna Bridge, Gulistan-Jatrabari flyover, Mukhtarpur Bridge etc. All this bridges are made with a collaboration of government and private companies. Now these bridges are maintaining by those private companies and they are taking their invested money by collecting toll from public who uses these bridges.



2.1. Figure: Proposed area, Meghna Bridge Toll booth

Our project is on this toll collection system and we considered Meghna Bridge as ideal one to implement our project. On our project we mainly considered on this Meghna Bridge because this

is the main way of Dhaka-Chittagong high way. Every day on these road lots of heavy vehicle passes. That is why our project will mainly implement a technologically innovative, more time saving; jam free and most digital way of collecting toll. In our project people can use the Electrical toll collection system in a very smooth way. There is different fixed rate for different types of vehicles. Toll taking system is designed in such a digital way that after paying the toll money passenger will have a text on their phone that how much money they have given for toll, so there will be no issues of taking over money, irregularities and corruptions. As the toll taking system will be so smooth that there will be no chances of having traffic jam. There is a weight sensor also where over weighted vehicles cannot use the bridge. This weight sensor will give alarm when it will found an over weighted vehicle is passing. That over weighted then cannot pass the bridge because this may harm the bridge.

2.2. Comparison between proposed and existing toll system

In our country the existing toll collection system have lots of bad sides. As money has to hand over by hand manually in the existing system, it takes more time then the electronic way to take the money. In existing system time wasting is a big issue because no one wants to waste their valuable time. On the other hand our proposed system is very time saving because it takes money automatically and give the passenger a text in his phone that how much money has deducted from his card, so passenger needs not to waste their time in giving money and asking for receipt.



2.2. Figure: Manual toll collection system

While waiting in a queue makes big jam in existing system because the high way roads are very busy and so many vehicles passes in every minutes but in proposed system there is no chance of waiting in a queue as the system is designed in such a way that it will be so smooth system to pay in toll plaza.



2.2.1. Figure: Waiting in queue for toll payment

Proposed toll system has no chances of corruption as it's done totally by an electronic device but in manual system chances of corruption is so high because that is totally done by hand to hand.

Our proposed system is really environment friendly because vehicles have not to wait to pay for toll and that is why less number of toxic gas are effecting environment. On the other hand existing system has a big hand to effect environment, as vehicles have to wait in queue for long time and that is why lots of toxic gas is coming out to pollute the air and cause the damage of environment.



2.2.2. Figure: Toxic gas coming out from vehicles

Existing system allows all vehicles to pass through the bridge, as the person collecting the toll doesn't care whether heavy vehicles may cause damage to the bridge. In the proposed system there is a sensor which will sense vehicles weight and if the sensor found over weighted vehicle it will give an alarm, so that the vehicle cannot pass the bridge. Moreover in our country we hardly think about bridges capability of taking weight. In manual system the management of bridge authorities does not worry about if this heavy load will hamper the bridge or not. In our project we do care about the bridge so we have added a weight sensor in front of toll plaza. So if any over weighted vehicle wants to get into the bridge the weight sensor will not allow it, by this the bridge will be safe and secured from any kind of threads.

2.3. Working principle of our project

We have designed our project in such a manner that it will be very much easy and comfortable to use for all kind of people. In front of toll plaza there will be a display where it will show welcome to the bridge. After a vehicle enters to the bridge he will go ahead to the toll plaza. When the vehicle will enter to the toll plaza it will be measured by a weight sensor. If the vehicle is in between the limit of weight allowances then it will not give any alarm but if the vehicle is more than the weight limit then it will start giving an alarm which will help the security not to give passes to that vehicle. Then it will come in front of the gate of toll plaza which is designed with servo motor.

Servo motor helps the gate to open up when it gets the signal from arduino. Arduino will only get the signal to servo motor if the actual toll is given for that vehicle. There will be RFID tag in every vehicles by which we can easily detect them. This RFID will also used as a registration of each car. All the vehicles will have an account as a general where they will keep certain amount of money to use the bridge every time. This account will be internally connected through each vehicles registration respectively. So that when ever that vehicle will pass only that vehicle will be entertained. When a vehicle will pay toll with his registered card then the amount of his toll will be deducted from his account. After that a message will send to his phone that how much toll he has paid and his remaining amount in his account. So there will be no issues of over toll taking or no waste of time in changing the money. The message will send to the phone by GSM module. The passenger also need not to worry for the receipt as the message will be automatically send when toll will be taken from the account of passenger. As the passenger pay the toll he will be allowed to use the bridge.

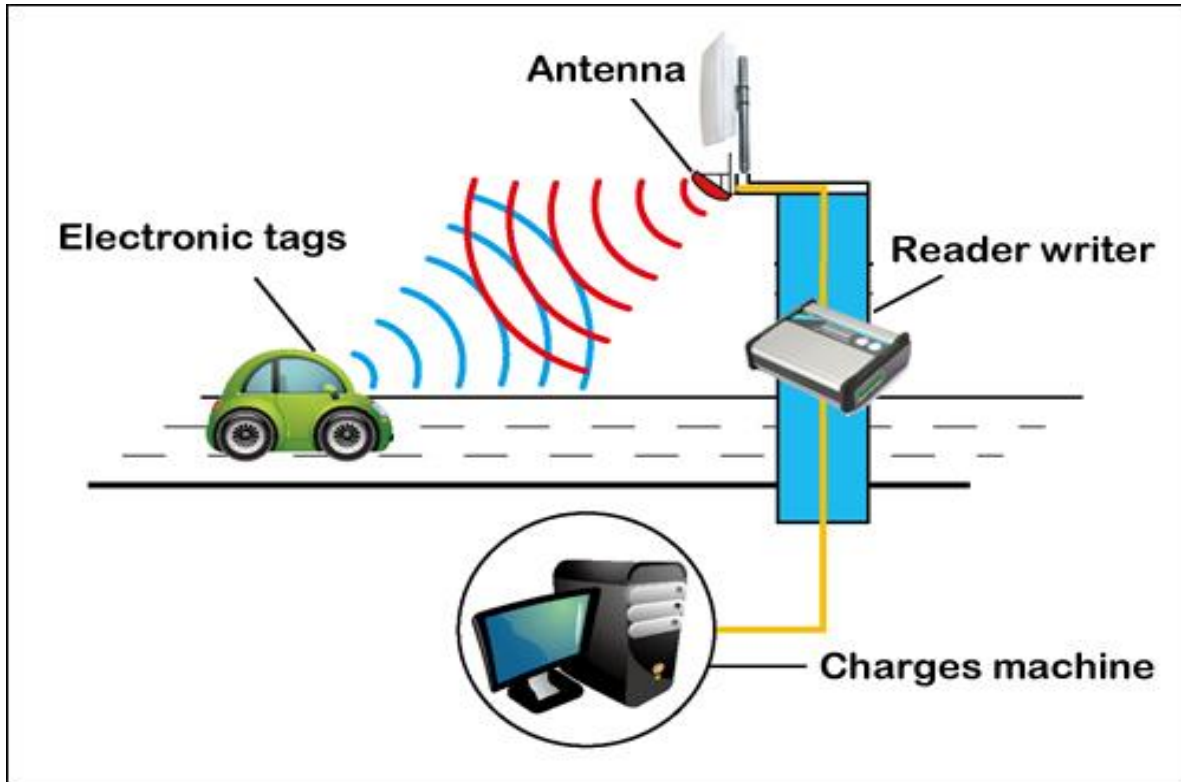

2.3.1. Figure: ETC toll collection system

2.4. Toll payment limitations

To pay the toll amount the passenger has to have money in his account. If the passenger don't have sufficient amount of money in his account then he will be not entertained. Different vehicle will have different amount of payment. In table 2.3.1 we can see the toll paying scale for different types of vehicle. As a prototype we are considering of two cases in our project. One case where the passenger has sufficient amount of money in his account to use the bridge and another is where the passenger don't have sufficient amount of money in his account to use the bridge. These two cases are given below in details.

Different types of Vehicles	Toll Rate (TK)
Two-wheelers	10
Auto-rickshaw	18
Car	60
SUV	70
Microbus	85
Pick-up vans	130
Minibus	173
Bus	260
Small Trucks	173

Trucks	260
lorries	345

Table 2.4: Different types of vehicle toll rate

2.4.1. Sufficient amount in account

Any of the vehicles using bridge will always need to have sufficient amount of money in his account. As the system is fully designed in a digital way so payment should be in online basis. In our prototype we are giving a sufficient amount of money in some vehicles to see the actual way of toll taking system.

2.4.2. Insufficient amount in account

It is always mandatory for any vehicle to have sufficient amount in his account but sometimes people may not remember how much money they have in their account. If any vehicle wants to use the bridge but don't have sufficient balance in his account then he will have to face a problem. He has to pay the money manually in hand and it will really take our project to that old manual system which we don't want. So, we ask all the vehicles to have sufficient amount in his account to have a simple smooth use of toll plaza. In our prototype we have kept a vehicle on this condition to see how it handles the situation. When the vehicle punch the card and the system finds that it has no sufficient balance in his account, the system gives an alarm and a message gone to passenger that he has less amount of money then what we required for. Then the passenger has to pay the money manually by hand and use the bridge.

Chapter 3

Hardware Components

3.1. Introduction

It is always important to have proper knowledge about all the hardware and software components of the project. We have used lots of components to make our project perfect. In our project the main and most important part is Arduino Mega R3 2560. We consider this part as the heart of our project because it contains all the software data in it. We have also used GSM module and SIM900A kit to send the information of toll submission to the toll plaza and this information will send to the vehicle user's phone. In our project there we also keep RFID, so that all the vehicles will be registered. Servo motor also has a major part in our project. It helps the toll gate to pull up and down after toll is paid by a vehicle. Weight sensor has added an extra feature in our project. It senses all the vehicles weight and allows only those vehicles to use the bridge, which are allowed for the bridge.

3.2. Hardware components

We have used lots of hardware and software components in our project. Now let's discuss about those components in below

3.2.1. Arduino Mega R3 2560

3.2.2. Load Cell 5kg

3.2.3. HX-711 Load Cell Amplifier

3.2.4. RC-522 13.56 MHz RFID Reader

3.2.5. Servo SG-91

3.2.6. LCD Display (16*2)

3.2.7. SIM900A kit

3.2.8. GSM Module

3.2.1. Arduino Mega R3 2560

Microcontroller used for our project is Arduino Mega R3 2560. The Arduino Mega R3 2560 is a microcontroller board based on the ATmega2560. It has 54 digital input/output pins (of which 15 can be used as PWM outputs), 16 analog inputs, 4 UARTs (hardware serial ports), a 16 MHz crystal oscillator, a USB connection, a power jack, an ICSP header, and a reset button. It contains everything needed to support the microcontroller; simply connect it to a computer with a USB cable or power it with an AC-to-DC adapter or battery to get started. The Mega is compatible with most shields designed for the Arduino Duemilanove or Diecimila. The Mega2560 features the ATmega8U2 programmed as a USB-to-serial converter.



3.2.1. Figure: Arduino Mega R3 2560

3.2.2. Load Cell 5kg

We used this load sensor to sense the weight of the vehicles, so that we can allow only those vehicles which will not be threat to the bridge. This load sensor allows maximum 5kg, above 5kg it will not allow. The major features of this sensor are given below.



3.2.2. Figure: Load Cell 5kg

Features:

- Capacity 5kg
- Wheatstone bridge sensor
- Small size: 55.25mm x 12.7mm x 12.7mm
- Plugs into the Phidgets, Phidget Bridge, Wheatstone Bridge Sensor Interface
- Compensated temperature range: -10°C to +40°C
- Operating temperature range: -20°C to +55°C
- RoHS compliant

3.2.3. HX-711 Load Cell Amplifier

In our project we has used HX-711 load cell amplifier because the signal of the load cell 5kg is too weak. This amplifier helps us to get a proper signal from the load cell 5kg. Load Cell Amplifier is a small breakout board for the HX711 IC that allows us to easily read load cells to measure weight. By connecting the amplifier to our microcontroller we will be able to read the changes in the resistance of the load cell, and with some calibration we'll be able to get very accurate weight measurements. This version of the Load Cell Amplifier features a few changes that we specifically asked for, it have separated the analog and digital supply, as well as added a 3.3uH inductor and a 0.1uF filter capacitor for digital supply.

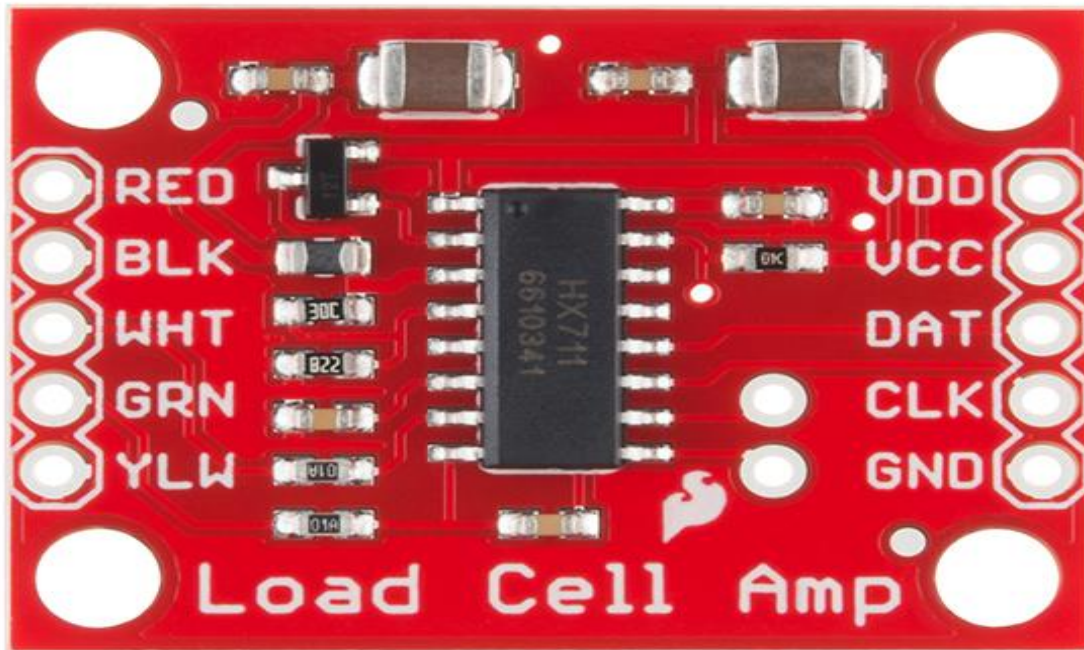

3.2.3. Figure: HX-711 load cell amplifier

The HX711 uses a two-wire interface (Clock and Data) for communication. Any microcontroller's GPIO pins should work, and numerous libraries have been written, making it easy to read data from the HX711. Load cells use a four-wire Wheatstone bridge configuration to connect to the HX711. The YLW pin acts as an optional input that are not hooked up to the strain gauge but is utilized to ground and shield against outside EMI (electromagnetic interference). Here are the features:

Features:

- Operation Voltage: 2.7V–5V
- Operation Current: < 1.5mA
- Selectable 10SPS or 80SPS output data rate
- Simultaneous 50 and 60Hz supply rejection

3.2.4. RC-522 13.56 MHz RFID Reader

This low cost MFRC522 based RFID Reader Module is easy to use and can be used in a wide range of applications. RC522 is a highly integrated transmission module for contactless communication at 13.56 MHz this transmission module utilizes an outstanding modulation and demodulation concept completely integrated for different kinds of contactless communication methods and protocols at 13.56 MHz

The MFRC522 is a highly integrated reader/writer IC for contactless communication at 13.56 MHz

Features:

- MFRC522 chip based board
- Operating frequency: 13.56MHz
- Supply Voltage: 3.3V
- Current: 13-26mA
- Read Range: Approx 3cm with supplied card and fob
- SPI Interface
- Max Data Transfer Rate: 10Mbit / s
- Dimensions: 60mm × 39mm



3.2.4. Figure: RC-522 13.56 MHz RFID Reader

Package contents

- 1 x Mifare RC522 Card Read Antenna RF Module
- 1x RFID plain white Card
- 1x RFID FOB
- 1x 8pin right angle header pins
- 1x 8pin straight header pins

Arduino Wiring

RC522 MODULE	UNO	MEGA
SDA(SS)	D10	D53
SCK	D13	D52
MOSI	D11	D51
MISO	D12	D50
PQ	Not Connected	
GND	GND	GND
RST	D9	D9
3.3V	3.3V	3.3V

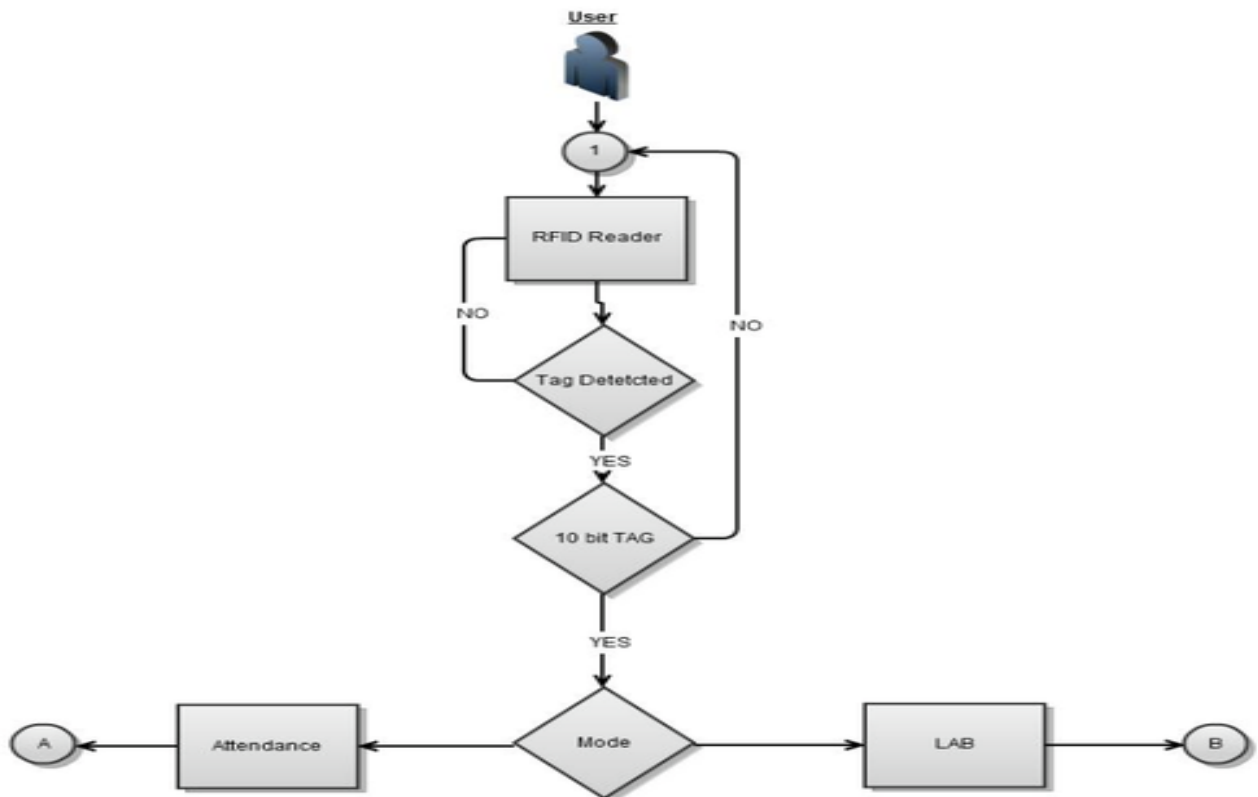

3.2.4.1. Figure: RC-522 13.56 MHz RFID Reader flow chart

3.2.5. Servo SG-91

The SG91 features plastic gears. SG91 weight 9g and Color of case – Blue. This is Tower Pro SG-91 Micro Servo for helicopter, 3D-flyer and F3A. It is very light. So we are using it to pull up and down the gate of the toll plaza pass way. It comes with a 3-pin power and control cable and mounting hardware.



3.2.5. Figure: Servo SG-91

- Dimension 23x12.2x29mm
- Stall torque 1.8kg/cm(4.8V)
- Operating speed 0.1sec/60degree(4.8v)
- Operating voltage 4.8V
- Temperature range 0 -55C
- Dead band width 10us

3.2.6. LCD Display (16*2)

LCD (Liquid Crystal Display) screen is an electronic display module and has a wide range of applications. This 16x2 LCD display is very basic module and is very commonly used in various devices and circuits. These modules are preferred over seven segments and other multi segment LEDs. The reasons being: LCDs are economical; easily programmable; have no limitation of displaying special & even custom characters (unlike in seven segments), animations and so on.

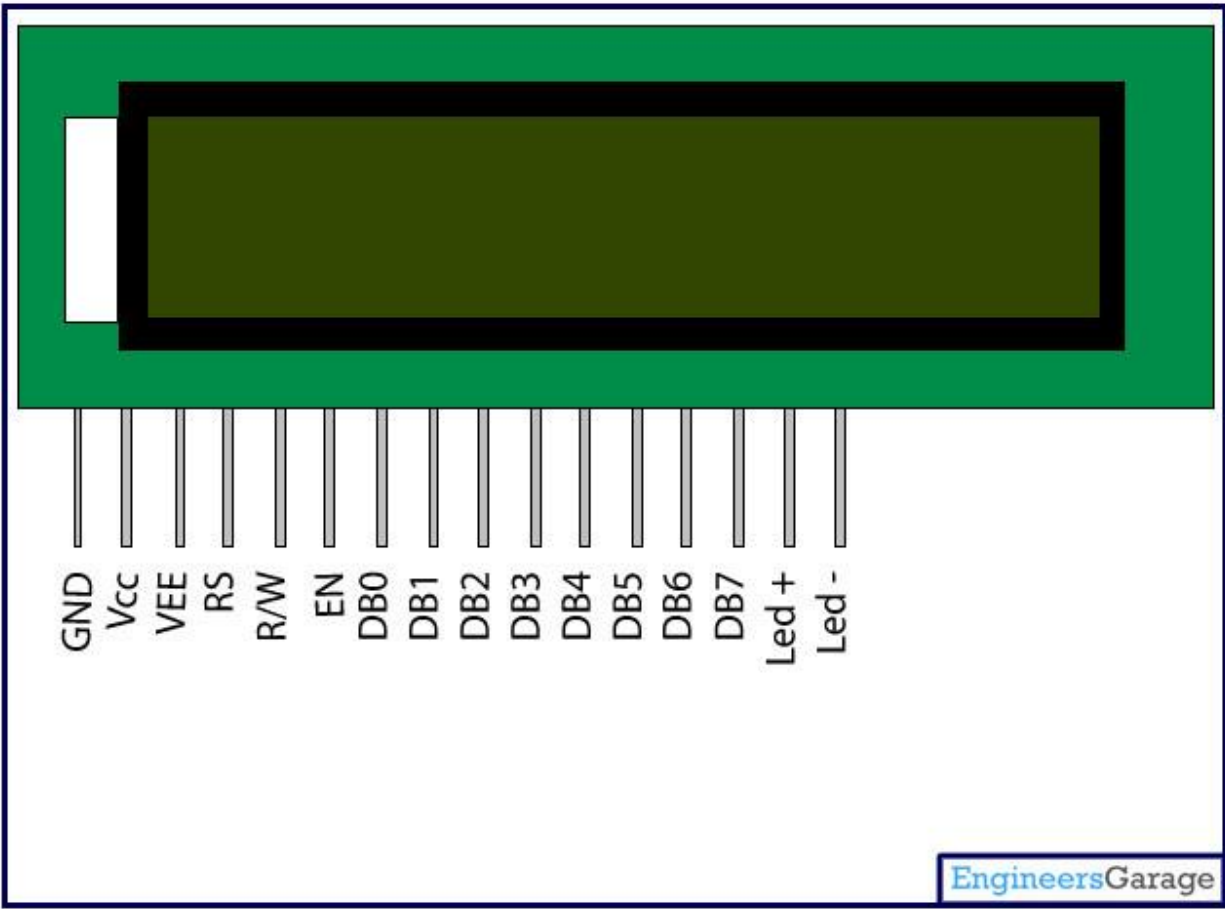

3.2.6. Figure: LCD Display (16*2)

A 16x2 LCD means it can display 16 characters per line and there are 2 such lines. In this LCD each character is displayed in 5x7 pixel matrix. This LCD has two registers, namely, Command and Data.

Pin No	Function	Name
1	Ground (0V)	Ground
2	Supply voltage; 5V (4.7V – 5.3V)	V _{cc}
3	Contrast adjustment; through a variable resistor	V _{EE}
4	Selects command register when low; and data register when high	Register Select
5	Low to write to the register; High to read from the register	Read/write
6	Sends data to data pins when a high to low pulse is given	Enable
7	8-bit data pins	DB0
8		DB1
9		DB2
10		DB3

11		DB4
12		DB5
13		DB6
14		DB7
15	Backlight V _{CC} (5V)	Led+
16	Backlight Ground (0V)	Led-

Table 3.2.6.1: LCD Display (16*2) connection

The command register stores the command instructions given to the LCD. A command is an instruction given to LCD to do a predefined task like initializing it, clearing its screen, setting the cursor position, controlling display etc. The data register stores the data to be displayed on the LCD. The data is the ASCII value of the character to be displayed on the LCD.

3.2.7. SIM900A kit

SIM900A kit module is version 3.4. It differs slightly from any module. The differences are:

- The Electro dragon module is version 3.6
- It has 3.3V to 5V and vice versa level translators onboard for the serial interface.
- It links the empty "Restart" pin to the "Powkey" input on the Sim 900 chip. The Electro dragon module schematic refers to the "Restart" pin as J12 but is drawn incorrectly, it actually connects to the base of the transistor, not to VCC as shown. R2 (R6 on theirs) is a 4k7 surface mount resistor and needs to install it if want to use the Restart input to power the mini module up or down. It will also need to remove the 4k7 resistor (R25) on the top side of the mini module as it connects the transistor base to the positive supply. This is done so that the mini module will always turn on automatically when power is applied, and if it's present we can't turn the module on or off under software control.
- There are a few other components shown on the schematic but are not installed on this module but they are not important to using it.

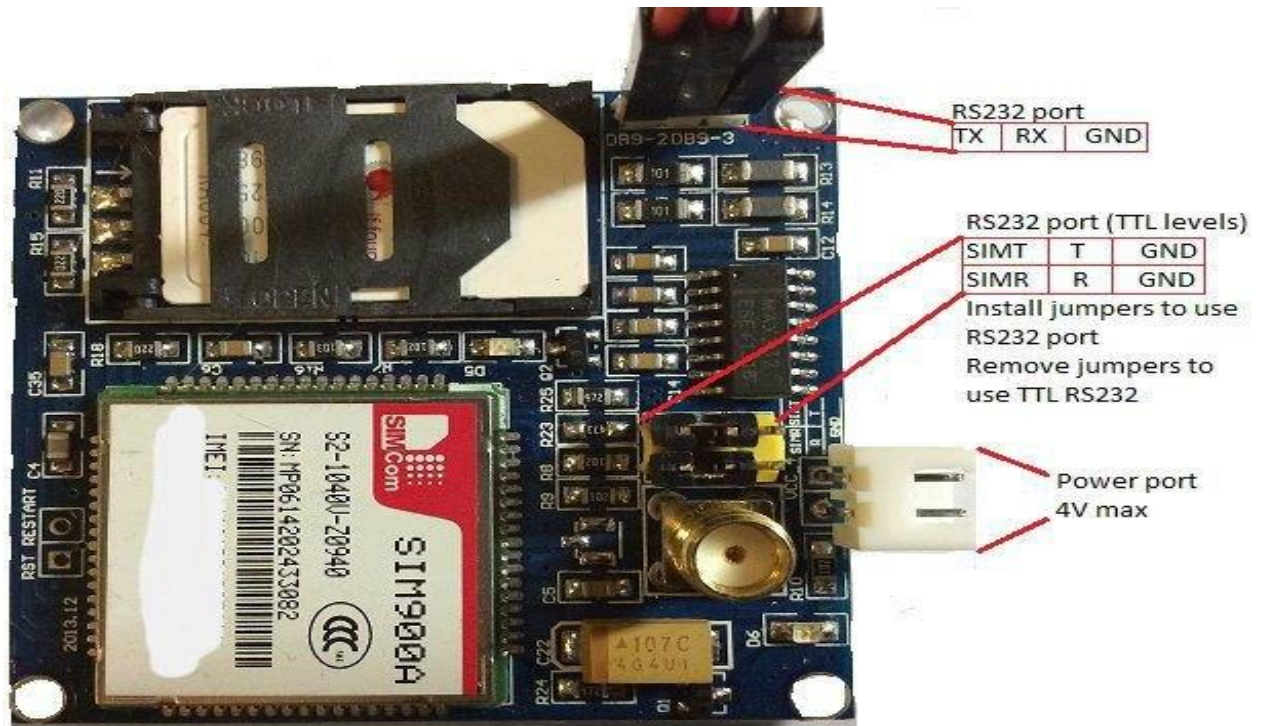

3.2.7. Figure: SIM900A kit

3.2.8. GSM Module

GSM/GPRS module is used to establish communication between a computer and a GSM-GPRS system. Global System for Mobile communication (GSM) is an architecture used for mobile communication in most of the countries. Global Packet Radio Service (GPRS) is an extension of GSM that enables higher data transmission rate. GSM/GPRS module consists of a GSM/GPRS modem assembled together with power supply circuit and communication interfaces (like RS-232, USB, etc) for computer. The MODEM is the soul of such modules.

GSM module can perform the following operations:

1. Receive, send or delete SMS messages in a SIM.
2. Read, add, search phonebook entries of the SIM.
3. Make, Receive, or reject a voice call.

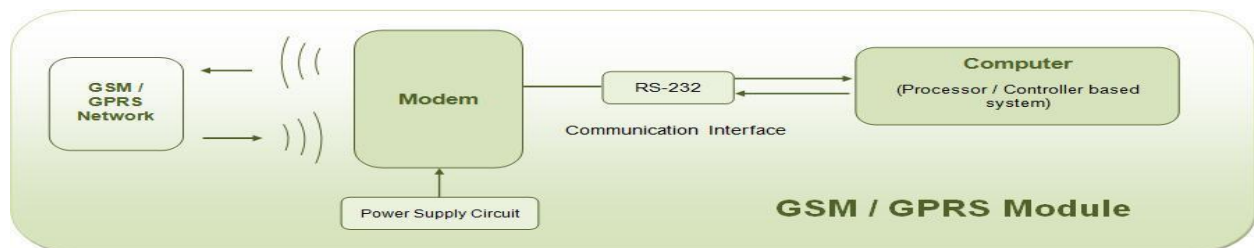

3.2.8. Figure: GSM Module working flow chart

GSM module assembles a GSM modem with standard communication interfaces like RS-232 (Serial Port), USB etc., so that it can be easily interfaced with a computer or a microprocessor / microcontroller based system. The power supply circuit is also built in the module that can be activated by using a suitable adaptor.

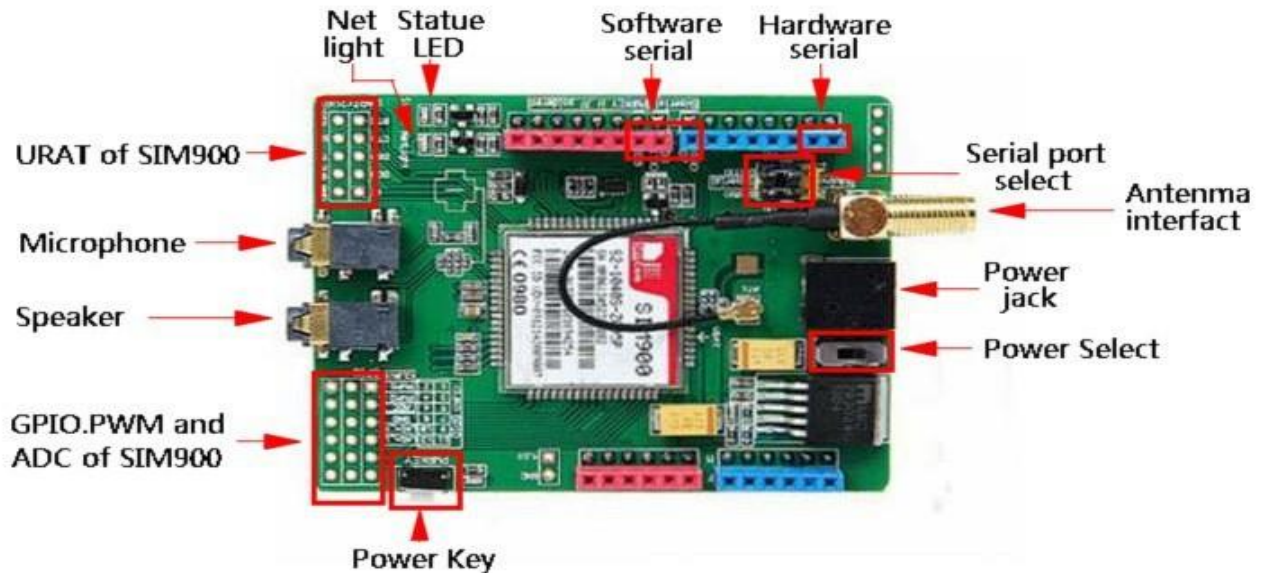

3.2.8.1. Figure: GSM Module

3.3. Software components

In this project, we built electrically toll collection system. In paying system RFID is used to receive data or information mainly latitude and longitude of the particular vehicle from the RFID tags by which payment will be done and the information will be transferred over mobile phone via Short Message Service (SMS) by using GSM modem. GSM modem is connected with Arduino Mega R3 microcontroller. The details information of software components are described below. The following software is used in this project.

3.3.1. Arduino IDE

3.3.2. Python

The description of Arduino IDE and Python is given bellow.

3.3.1. Arduino IDE

As we want to design Electronic Toll Collection (ETC) system, we need to have some knowledge in different types of programming languages by which we can easily build a connection between microcontroller and GSM SIM module and also can store and retrieve data

in memory. To receive data from the RFID and send it to the GSM module, Arduino microcontroller and SIM900A kit module had been programmed by the Arduino IDE software.

It is known that Arduino IDE is open source software. It is used to compile the program into the microcontroller. C- Programming language is used for coding in this software. There is two parts in this code mainly. Void setup () is known as preparation for the program and it runs only once, void loop () is known as execution for the program. In this software we have written some function to get the authentication of SIM, GPS data, send the data to the script with HTTP. To send message to the mobile we used AT command for SIM900A kit to connect with the Arduino.

3.3.2. Python

Python is an easy to learn, powerful programming language. It has efficient high-level data structures and a simple but effective approach to object-oriented programming. Python's elegant syntax and dynamic typing, together with its interpreted nature, make it an ideal language for scripting and rapid application development in many areas on most platforms.

The Python interpreter is easily extended with new functions and data types implemented in C or C++ (or other languages callable from C). Python is also suitable as an extension language for customizable applications.

Here are some bullet points for using Python developing

- Using 4-space indentation, and no tabs.

4 spaces are a good compromise between small indentation (allows greater nesting depth) and large indentation (easier to read). Tabs introduce confusion, and are best left out.

- Wrapping lines so that they don't exceed 79 characters.

This helps users with small displays and makes it possible to have several code files side-by-side on larger displays.

- Using blank lines to separate functions and classes, and larger blocks of code inside functions.
- When possible, putting comments on a line of their own.
- Using doc strings.
- Using spaces around operators and after commas, but not directly inside bracketing constructs: `a = f (1, 2) + g (3, 4)`.
- Naming the classes and functions consistently; the convention is to use Camel Case for classes and `lower_case_with_underscores` for functions and methods. Always used self as the name for the first method argument.
- Didn't use fancy encodings as our code is meant to be used in international environments. Python's default, UTF-8, or even plain ASCII works best in any case.

Chapter 4

Proto type Mechanism and Algorithm

Mechanism and Algorithm

4.1. System Design:

Digital Toll Plaza is made up with Arduino Mega R3 2560, SIM900A kit module and GSM antenna. The core part of tracking system is microcontroller Arduino Mega R3 2560. Most of the coding of our system is design in the Arduino Mega R3 2560. We use Arduino IDE programming language to run the whole system of our digital toll plaza.

Then we have used RFID tag to read the vehicle information. Here we have used RC-522 13.56 MHz RFID Reader because RC522 is a highly integrated transmission module for contactless communication at 13.56 MHz this transmission module utilizes an outstanding modulation and demodulation concept completely integrated for different kinds of contactless communication methods and protocols at 13.56 MHz. After reading all the information with the help of RFID tag then instruction will be shown in the Display monitor. Here we have used LCD 16*2 display. After reading all the information by RFID tag if everything is correct then LCD will show “you shall go” if not then it will show “You cannot pass”. LCD (Liquid Crystal Display) screen is an electronic display module and has a wide range of applications. This 16x2 LCD display is very basic module and is very commonly used in various devices and circuits.

Another most important component we have used is GSM module which will send information to the mobile of the vehicle owner to let them know their account information of toll bill. GSM module is used to establish communication between a computer and a GSM-GPRS system. Global System for Mobile communication (GSM) is an architecture used for mobile communication in most of the countries.

To maintain the health of the roads or bridge we have used Weight sensor which is Load Cell 5kg. We used this load sensor to sense the weight of the vehicles, so that we can allow only those vehicles which will not be threat to the bridge. This load sensor allows maximum 5kg, above 5kg it will not allow.

After GSM, RFID tag, Weight sensor then come Servo Motor. We are using Servo SG-91. We are using it to pull up and down the gate of the toll plaza pass way. It comes with a 3-pin power and control cable and mounting hardware.

After maintaining all this operation a vehicle can pass the Toll plaza.

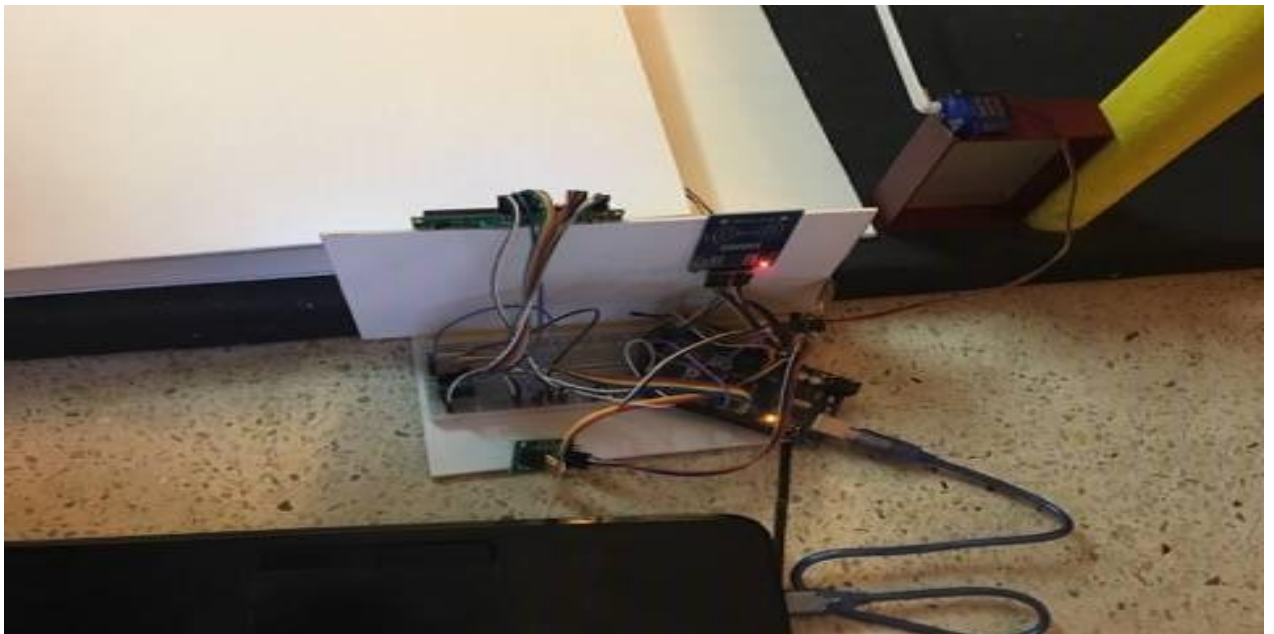

4.1. Figure: Mechanism instrument settings

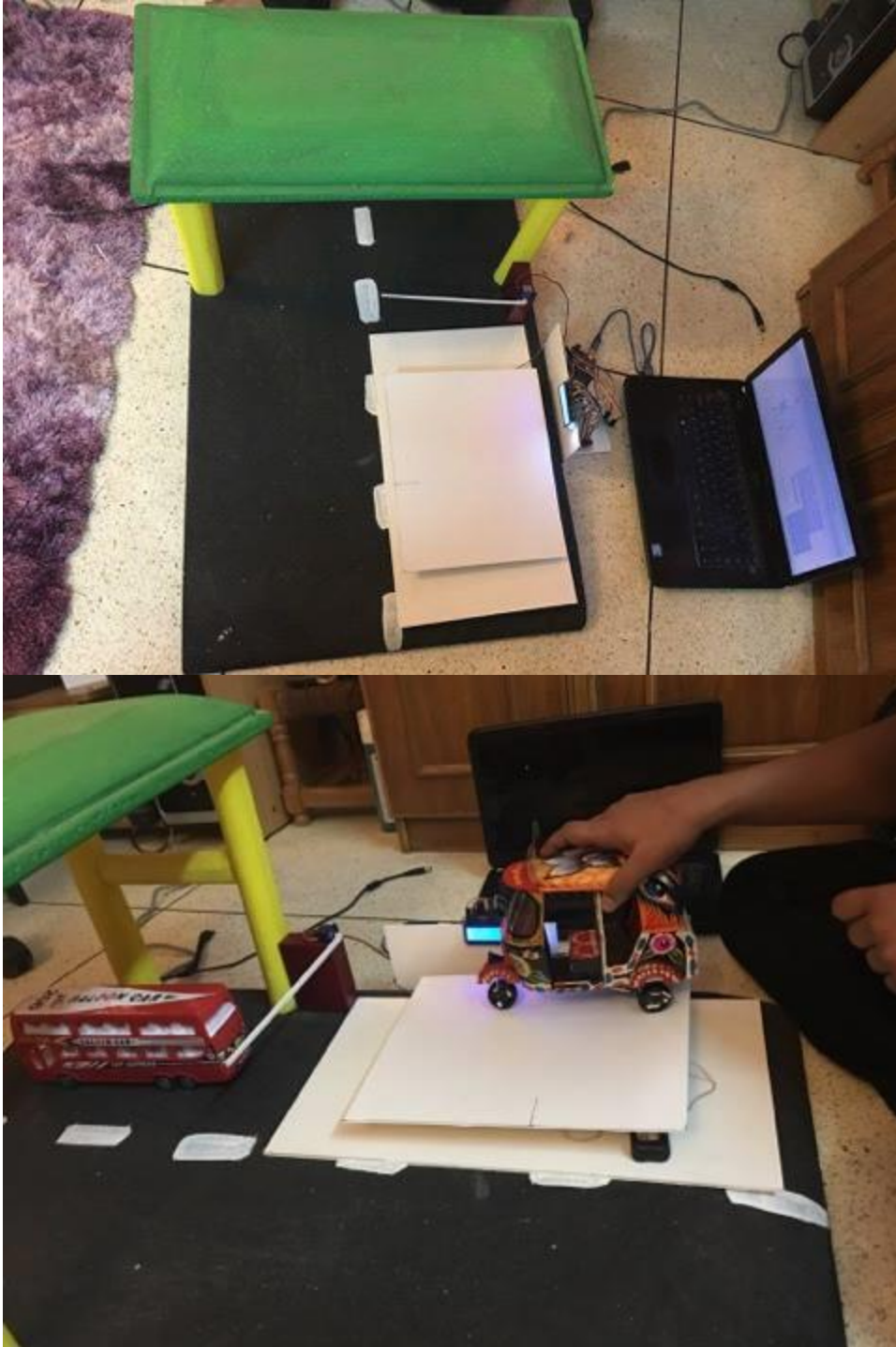

4.1.1. Figure: Our System outlook

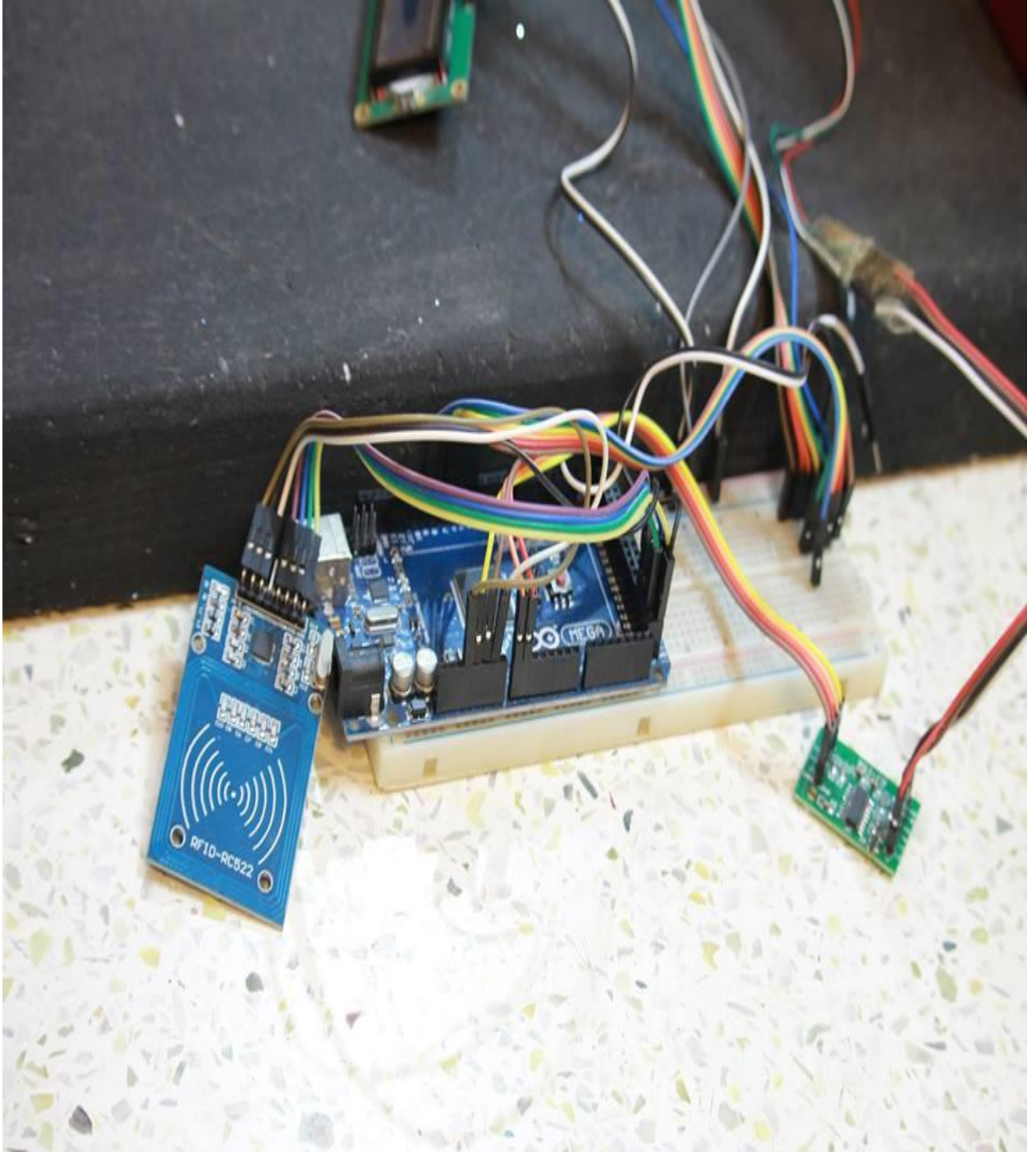

4.1.2. Figure: RFID setup with Arduino

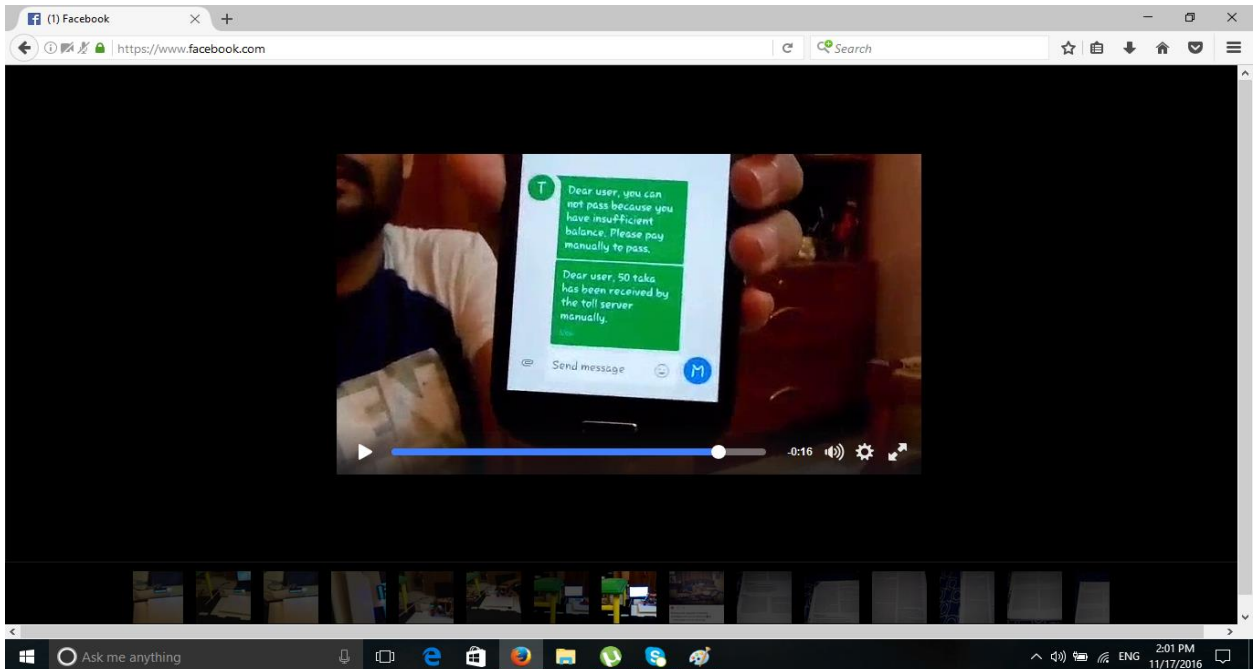
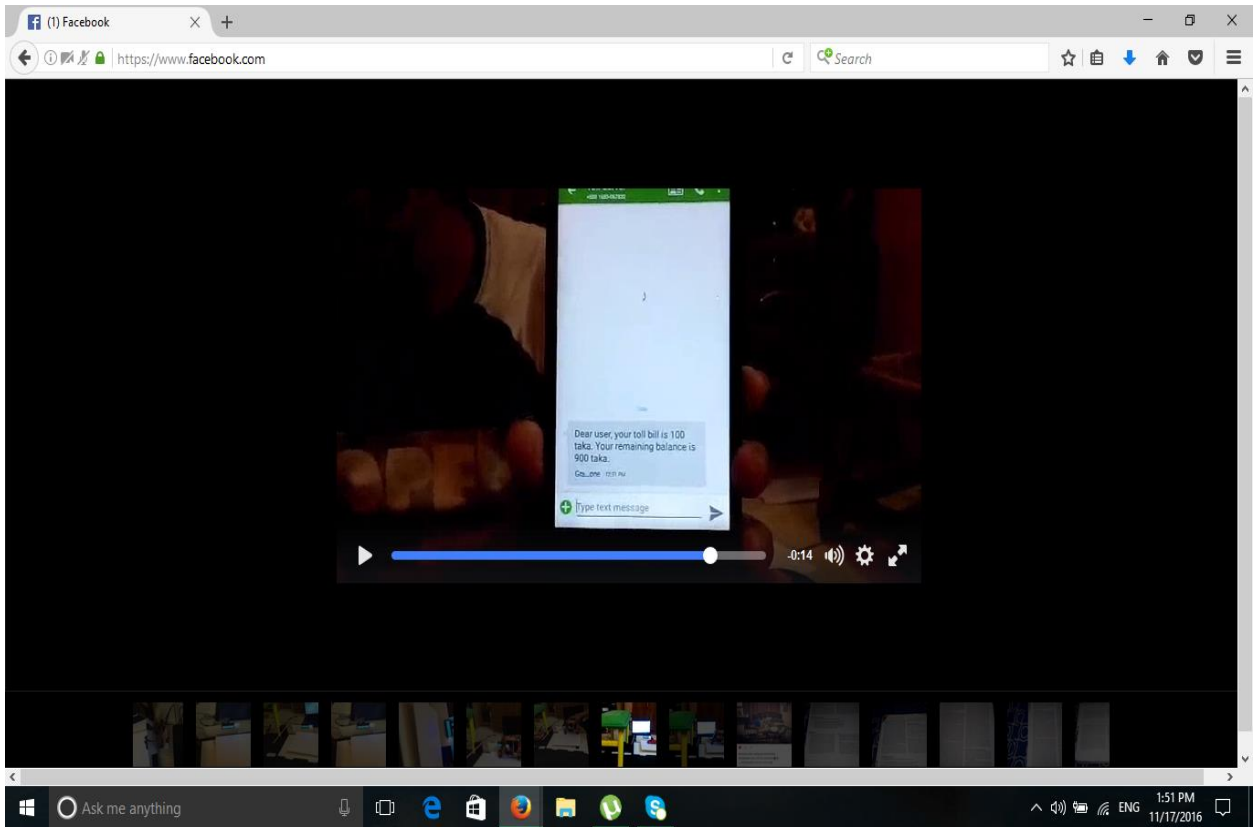

4.1.3. Figure: SMS sending in mobile phone using GSM module

4.2. Algorithm:

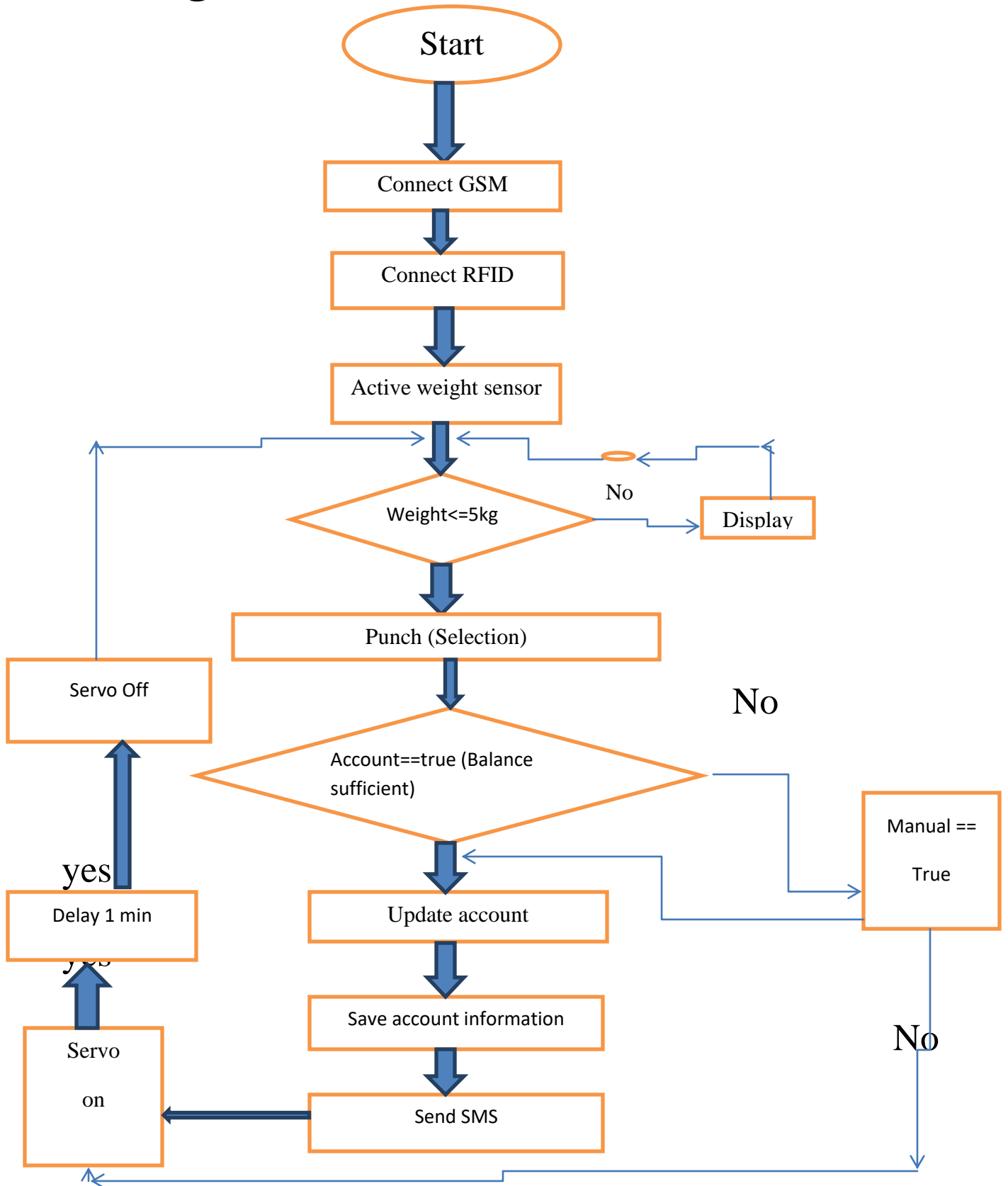

4.3. Working procedure of proto type:

When a vehicle will come close to the toll plaza the GSM module will become active and at the same time RFID tag will read all the information of the vehicle. After that all the data will be sent to GSM module and then data will be sent to the PC via Arduino programming. Then the weight sensor will start working and if the weight of the vehicle is 5kg or less then the vehicle is allowed to pass the toll plaza. Before this our system will start working to verify the account of the vehicle and if the account has sufficient balance then vehicle owner will get a SMS to his/her phone and the toll payment will take from the owner account. After finishing all these, data will be sent to the PC for creating a data base system by using “Python” programming language. If the account of the vehicle has insufficient balance then there is an option to pay the bill manually. After all these LED display will Show “You shall pass”. If the account has any problem like insufficient balance or the vehicle is over weighted then the LED display will show “you cannot pass”. When the Display shows “you shall pass” at the same time the Servo motor will start working and after sometime the gate will be open for the vehicle to pass the toll plaza. After 1 minute the Servo motor will be stopped and gate will be again closed for the next vehicle.

Thus our digital toll plaza works like non stoppable way.

4.4. Display results:

SMS:

All the information whether the vehicle owner’s account has sufficient balance or not and whether the vehicle can pass or not will be sent to the vehicle owner through SMS to his/her phone.

The picture:

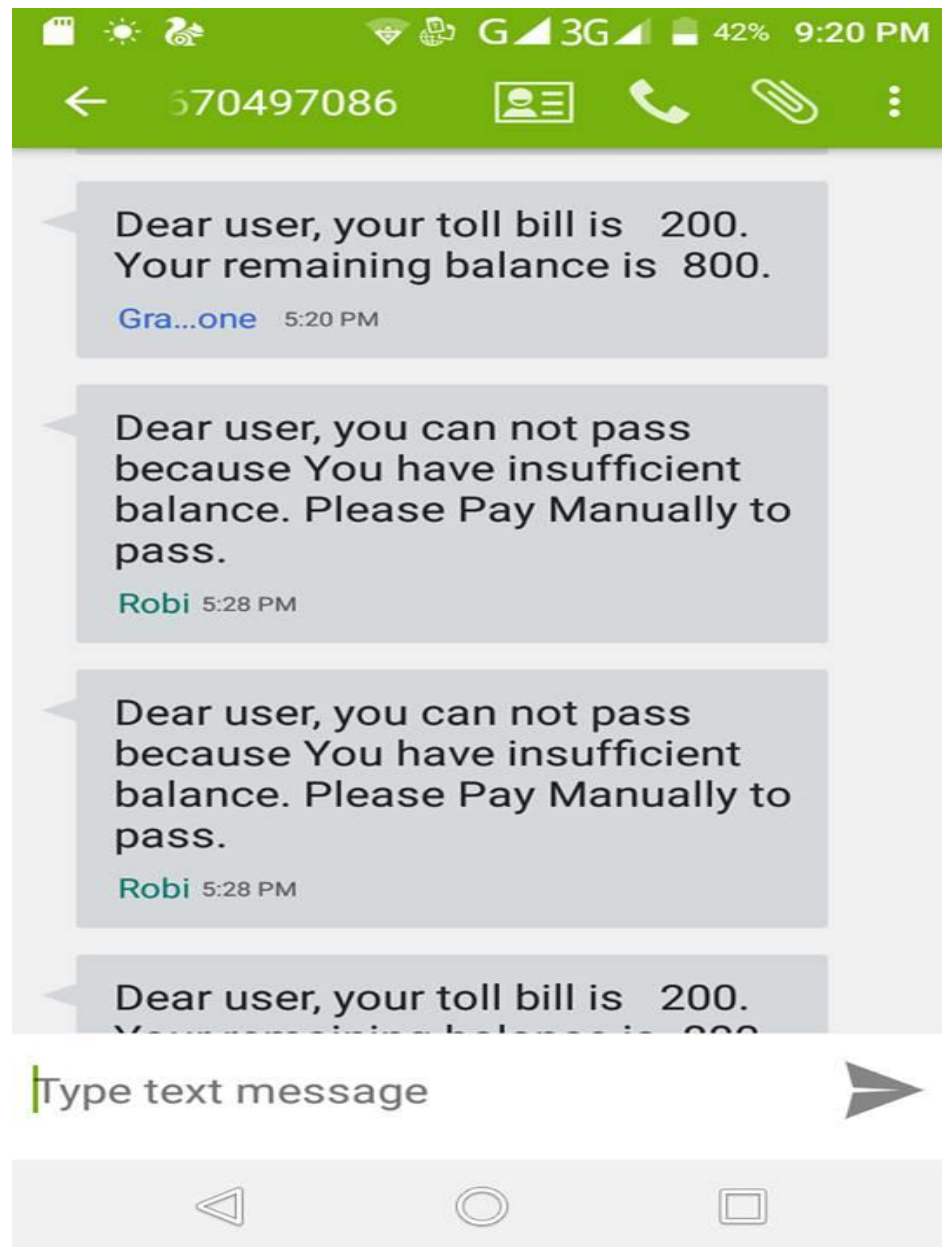

4.4. Figure: SMS Screen shot

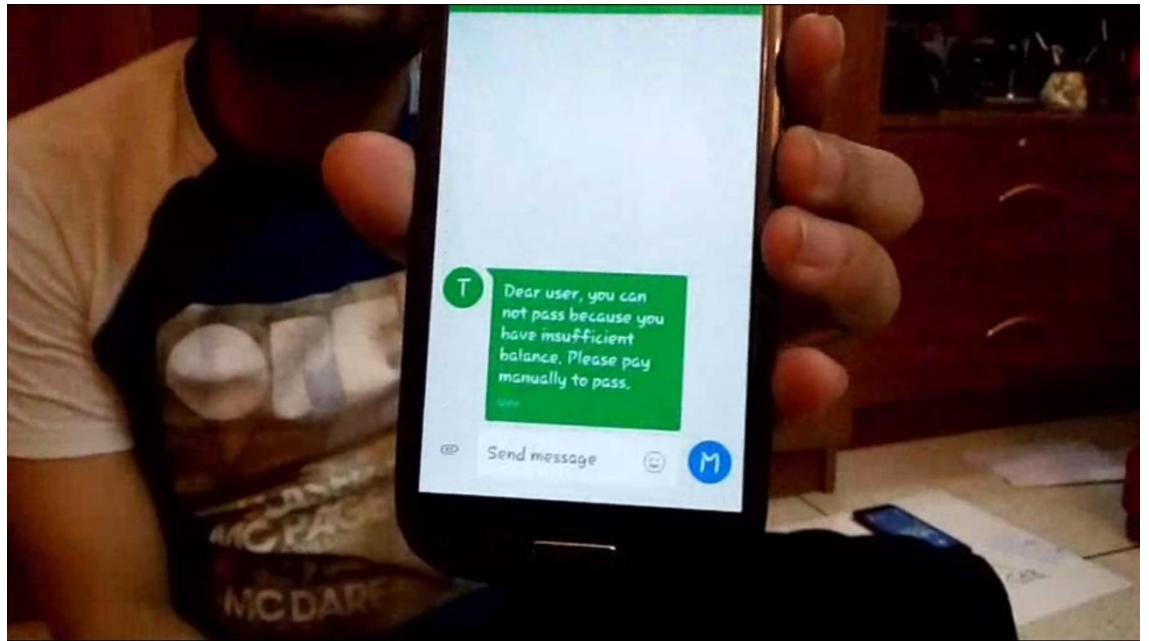

4.4.1. Figure: SMS showing the transport cannot pass because of insufficient balance

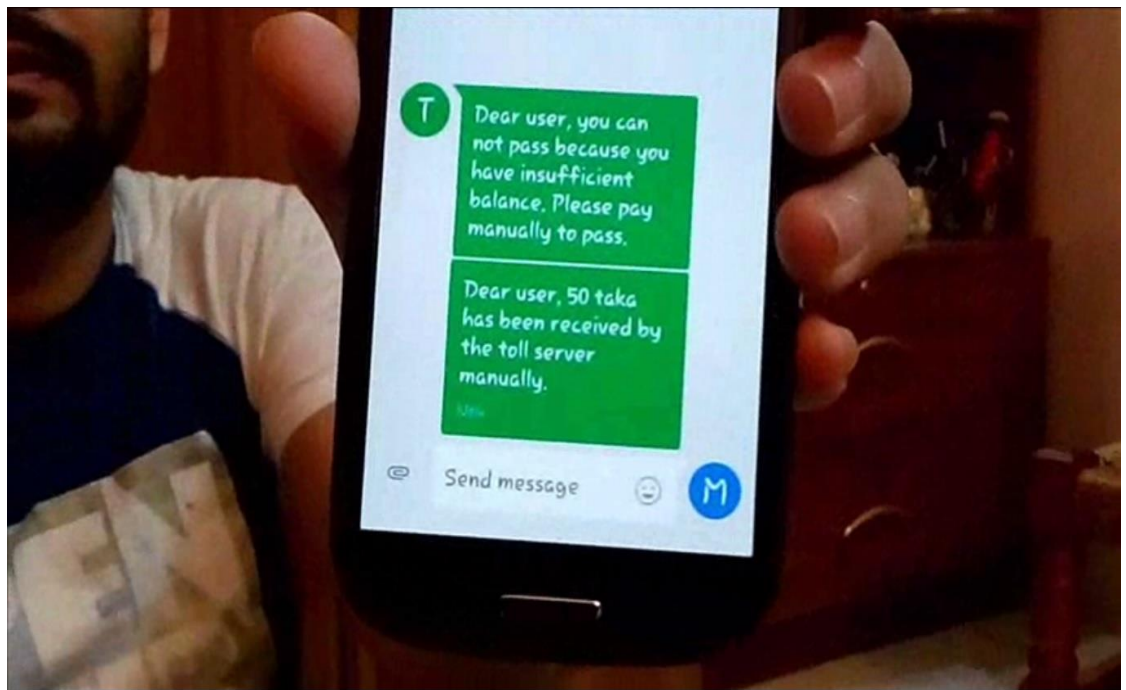

4.4.2. Figure: SMS showing the transport has insufficient balance, so it has to pay manually. After paying manually the transport can pass

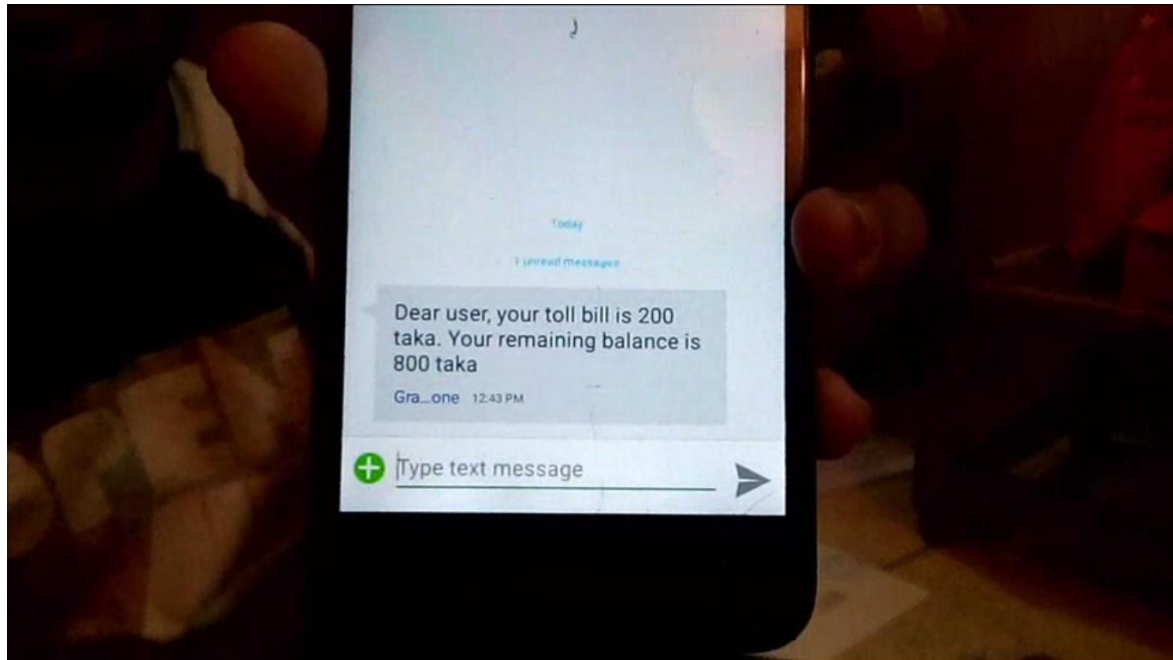

4.4.3. Figure: toll collected from a bus

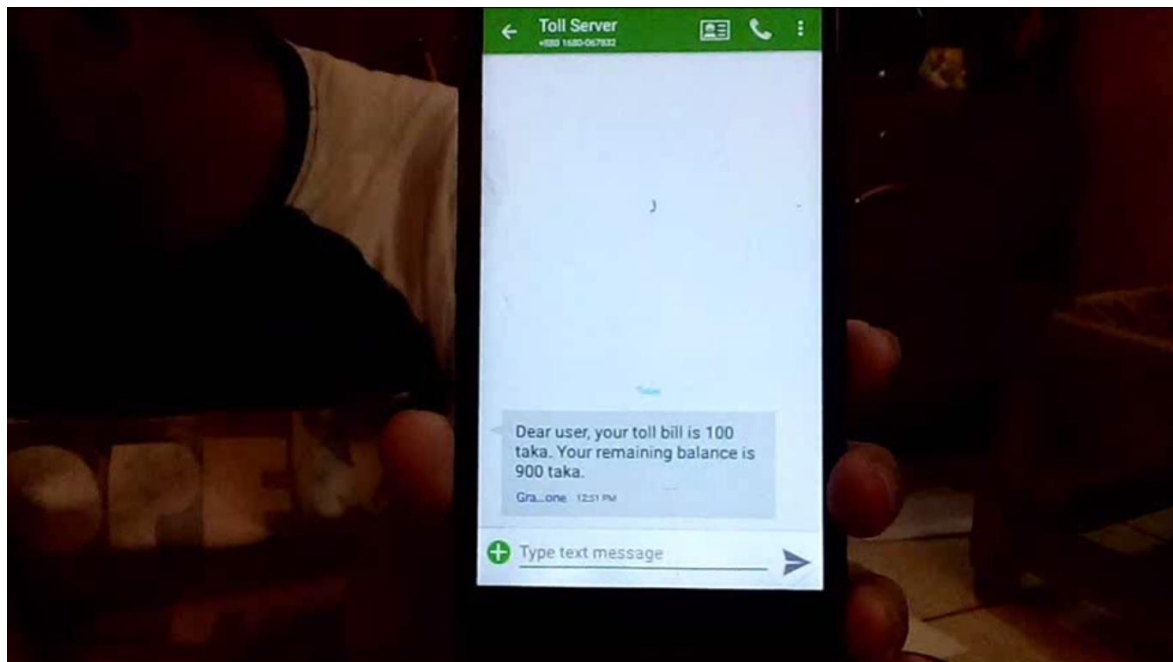

4.4.4. Figure: Toll collected from a car

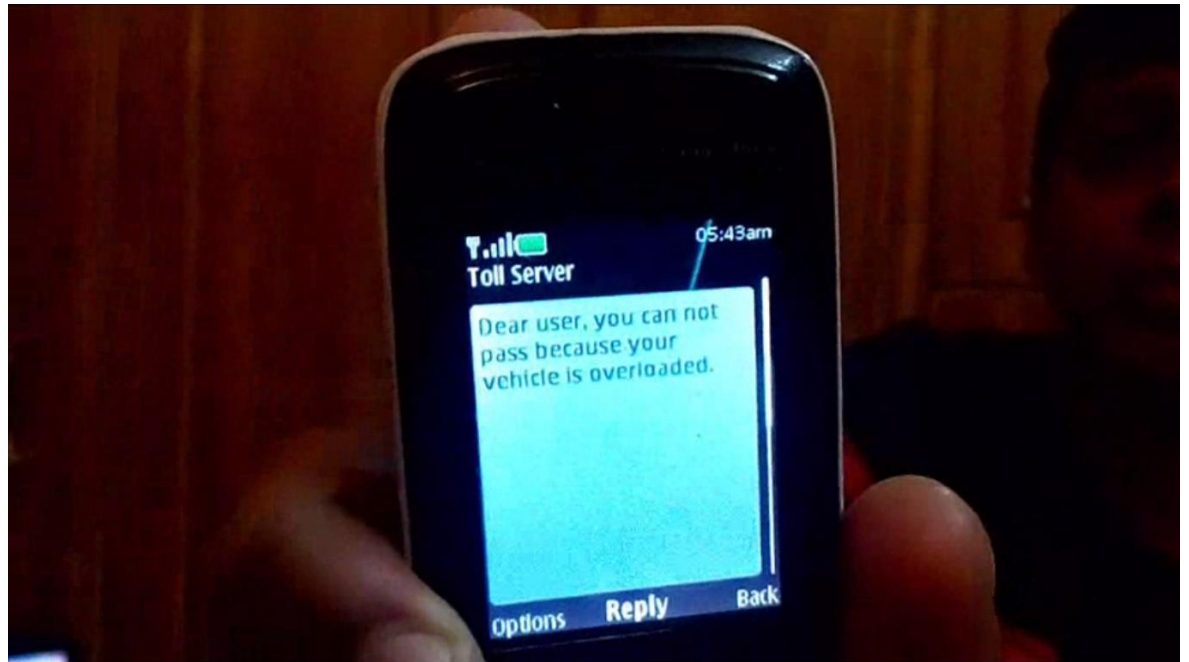

4.4.5. Figure: SMS showing the transport cannot pass because of over weight

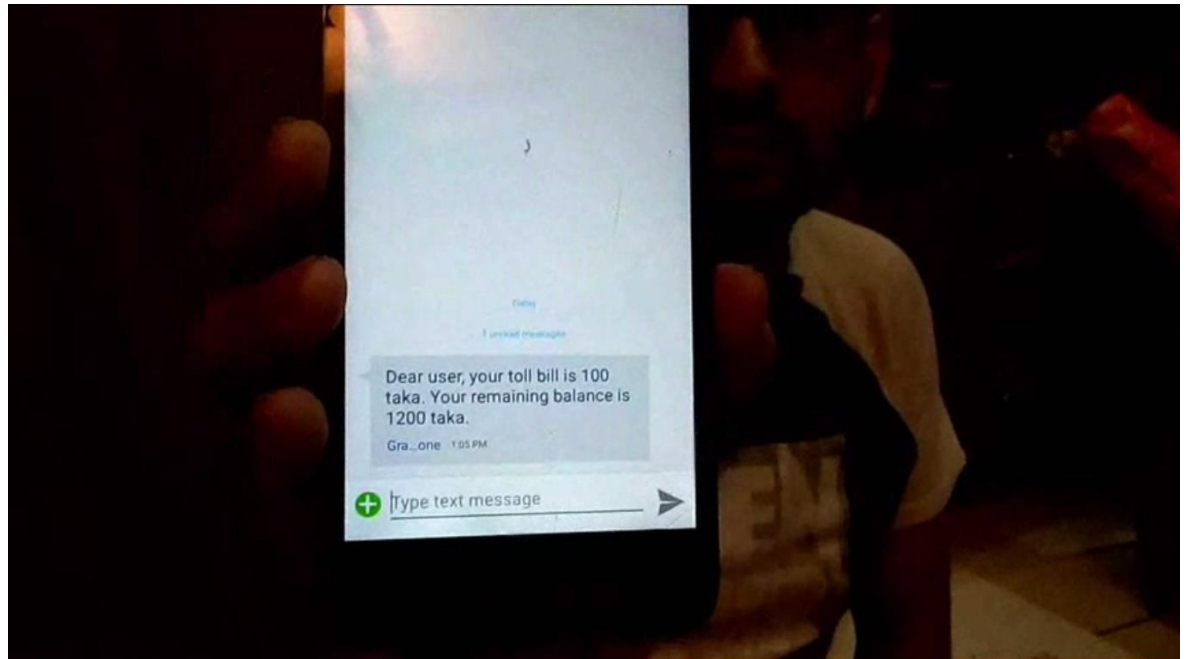

4.4.6. Figure: Toll collected from another car

4.5. Computer Display:

In computer display we are getting the real time information of the passing vehicles including the toll payment record. After passing the each transport the total amount of toll payment is added automatically. Then also the total summation is happening automatically in real time. After completing every 24 hours or 1 day, the total amount of toll will be shown in a different note pad file. From this newly created file we will get the full amount of toll and also get the information how much toll had been pay from which vehicle.

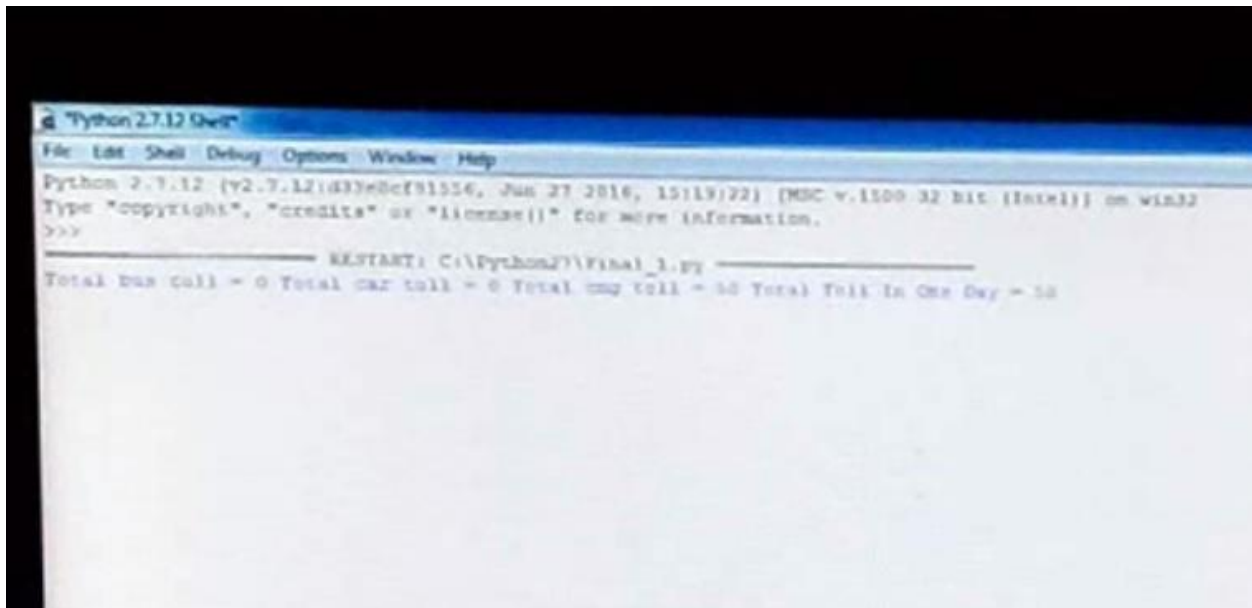

```
Python 2.7.12 Shell
File Edit Shell Debug Options Window Help
Python 2.7.12 (v2.7.12:8320e0cf91556, Jun 27 2016, 15:19:22) [MSC v.1500 32 bit (Intel)] on win32
Type "copyright", "credits" or "license()" for more information.
>>>
----- RESTART: C:\Python27\Final_3.py -----
Total bus toll = 0 Total car toll = 0 Total truck toll = 50 Total Toll In One Day = 50
```

4.5. Figure: display showing the manually collected toll

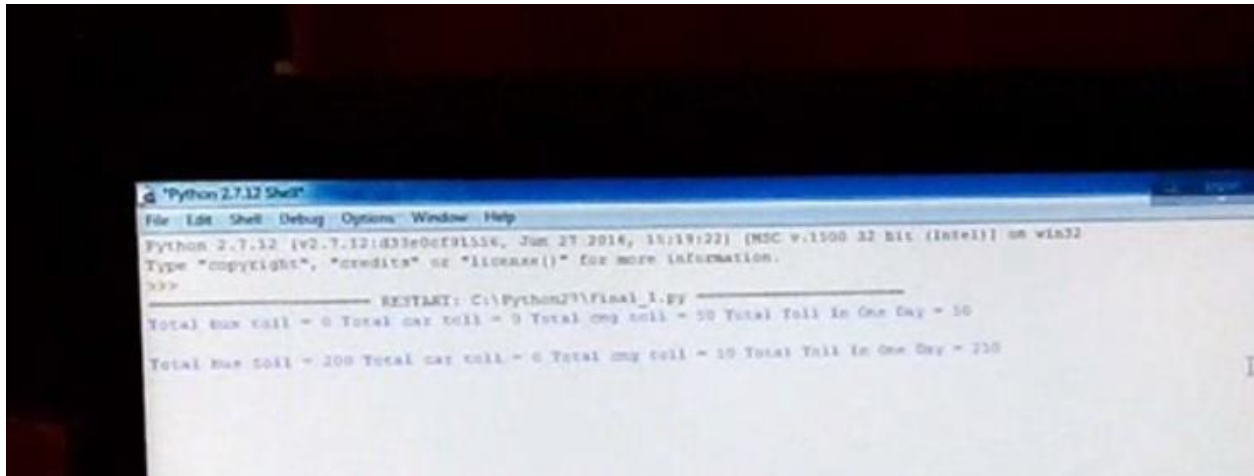

4.5.1. Figure: display showing the data of toll collection from a bus

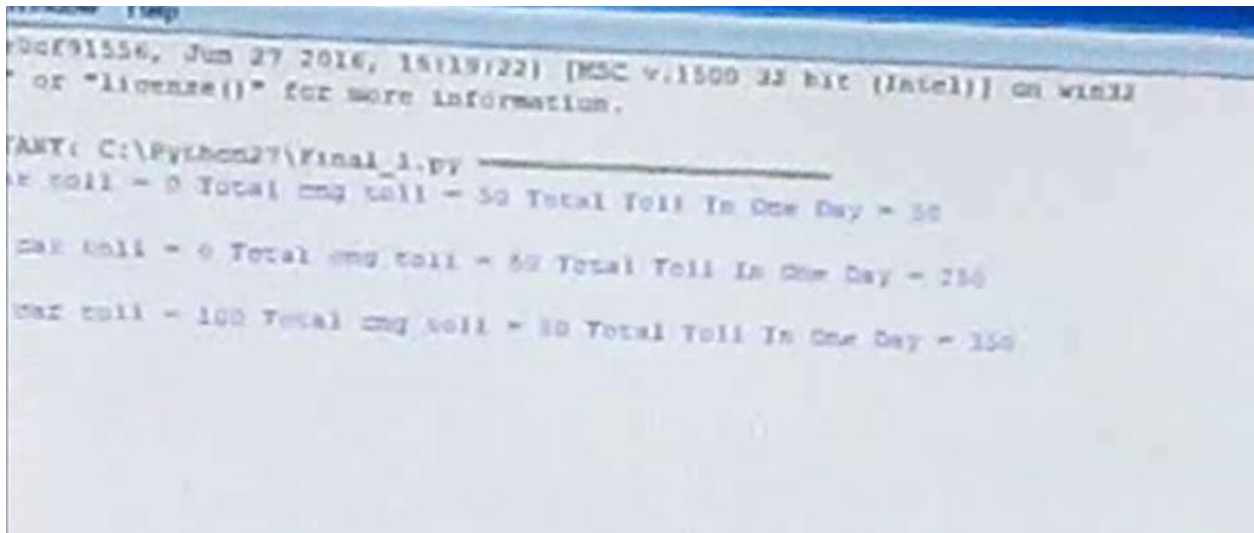

4.5.2. Figure: display showing the data of toll collection of a car

```
Python 2.7.12 Shell
File Edit Shell Debug Options Window Help
Python 2.7.12 (v2.7.12:d33e0cc91556, Jun 27 2016, 15:19:22) [AMD64 v.1560 32-bit (Intel)] on win32
Type "copyright", "credits" or "license()" for more information.
>>>
----- RESTART: C:\Python27\Final_1.Py -----
Total bus toll = 0 Total car toll = 0 Total cng toll = 50 Total Toll In One Day = 50
Total bus toll = 200 Total car toll = 0 Total cng toll = 50 Total Toll In One Day = 250
Total bus toll = 200 Total car toll = 100 Total cng toll = 50 Total Toll In One Day = 350
Total bus toll = 200 Total car toll = 200 Total cng toll = 50 Total Toll In One Day = 450
>>> |
```

4.5.3. Figure: result showing in Python

```
2016,11,17 - Notepad
File Edit Format View Help
Total bus toll = 200 Total car toll = 200 Total cng toll = 50 Total Toll In one Day = 450
```

4.5.4. Figure: Result displaying in a notepad (saved all data in total amount)

Chapter 5

Economic Overview

5.1. Present toll collection system economic losses

In present toll collection system there is lots of lacking. In this system vehicle has to stop, money has to handed over by hand, wait for receipt and then accelerate and get rid of toll plaza. This process takes extra time which increase the user cost, more over air pollution due to deceleration and acceleration and as usual huge traffic jam.



5.1. Figure: Waiting for toll payment

In Bangladesh Road User Costs (RUC) are the costs borne by the people through use of the road network facility. There are three types of cost that usually road users have to pay. Those are construction cost, maintenance cost and road user cost. As construction and maintenance costs are done by the concerned road development agency, so road user costs are borne by the users of road output. Mainly road user cost depends on traffic plying on road. In 1994 an empirical study by the Organization for Economic Cooperation and Development (OECD) showed that costs-shares under optimal maintenance situation of road infrastructure the proportion of RUC is about 38% on a road with 50 vehicles per day, about 75% on a road with 300 vehicles per day and above 90% on a road with 5000 vehicles per day. A proper and timely maintenance of the road

network and reducing obstructions pose through various activities like toll collection can help to reduce road user costs.



5.1.1. Figure: Allowing vehicles without taking proper toll

In present toll collection system there are lots of corruption ways. For example, some time tolls are being collected without giving any receipt in case of manual toll collection system. As a result government is losing revenue from it.

5.2. Proposed toll system economic benefits

1. RFID tags will provide vehicle identification at toll plazas which will reduce delays through reduced transaction times.
2. Automatic toll collection system comes up with significant opportunities for example cost reduction and staff reductions. It also gives a big improvement to security system by eliminating physical money handling transactions.
3. In this system there are no chances for patron or staff abuse. No one can be entertained without paying the toll and none of the staff can do pocketing of some funds.

4. Reducing fuel consumption by removing the need to stop and eliminating deceleration or acceleration time.
5. Climate is changing and its one of the major reason is air pollution. This system can help us to reduce the air pollution by making toll collection automatic.



5.2. Figure: Proposed toll collection system

5.3. Equations for data analysis

If we consider about savings then it can be divided into three following subgroups: fuel savings, labor cost savings and time savings. We will only consider this savings for Meghna Bridge and the analysis is also done for it.

1. The number of vehicles using ETC system in one day (24 hours) is calculated using the following equation:

$$ETC_o = TV_o * i_o$$

Where:

TV_o : Total number of vehicles that pass a tollbooth in a day (24 hours)

i_o : Percent vehicles using the ETC system

2. Reduced travel time for vehicle due to utilization of ETC system instead of the current method, is calculated as follows:

$$T_{etc} = t_{cash} - t_{etc}$$

Where:

t_{cash} : Stop time for a vehicle to pay the toll manually

t_{etc} : Payment time for a vehicle in the ETC system with no stops

Reduced time for a vehicle due to elimination of deceleration or acceleration in tollbooth area would be calculated using the following equation: [Ref.7]

$$T_o = t_o + t1 - t$$

$$t_o = d_o / v_d$$

$$t1 = d1 / v_d$$

$$t = d / v$$

Where:

t_o : Tollbooth approach time. It is calculated as the time it takes for the vehicle to stop in front of booth, from the moment it starts to decelerate.

$t1$: Tollbooth leaves time. It is calculated as the time it takes for the vehicle to reach its normal speed, from the moment it leaves the booth.

t : Travel time between two ramps with normal speed.

$d_o, d1$: Distance required for a vehicle to decelerate from normal speed until it stops or to increase speed to reach normal which is called ramp.

v_d, v_o : Average speed of the vehicle during deceleration or acceleration period

d : Distance between the ramp before and after tollbooth

v : Average normal speed of the vehicle

If T_q is the reduced time for a vehicle due to elimination of waiting in a queue, the total reduced time that is a function of payment time, deceleration, acceleration, and waiting in a queue, would be:

$$TS = T_{etc} + T_o + T_q$$

3. Fuel consumption should be considered in two ways:

Average fuel consumption per hour for a vehicle while moving:

$$FC_v = v/df$$

Where df is the average distance of a vehicle has passed using one liter fuel.

If FC_v taken as vehicle fuel consumption per second during stop time, the total fuel saving for a vehicle in a day can be calculated as:

$$FS_v = FC_v * (T_{etc} + T_o) + FC_i * T_q$$

FS is the total fuel saving in a day that if multiplied by the number of days in a year, would give the total fuel saving per year.

Therefore, the total fuel saving per year can be calculated as:

$$FS = 365 * ETC_o * FS_v$$

5.4. Data analysis and results

Having all the equation, it is easy to calculate fuel savings as a result of ETC system installation. Here we are considering only the Meghna Bridge toll system. It is an approximate calculation:

Item	Meghna Bridge (ETC System)	Meghna Bridge (Manual System)
Total number of vehicles per day	9,704	9,704
Percent vehicles estimate to use ETC system	94%	100%
Payment time (second)	35	105
Total reduce time when using Toll Collection system (Seconds)	27	0
Distance between before and after tollbooth ramp (km)	0.37	0.37
Vehicle average speed during deceleration/acceleration (km/h)	40	20
Tollbooth approach or leave time (Second)	33.3	99.9
Reduced time due to elimination of deceleration/acceleration (Seconds)	66.6	0
Average waiting time in queue (Second)	240	960

Fuel consumption in one second stop (liter)	0.00033	0.00033
Total waiting time in a queue a day (Second)	240.012	960.048
Total reduced time per day (Seconds)	277.8012	0
Fuel consumption per 100 km (liter)	10	2.5
Average distance traveled using one liter fuel (km)	12	11
Total fuel consumption per day (liter)	0.15	0.45
Total fuel consumption per year for a vehicle (liter)	54.75	164.25
Total cost per year for fuel consumption (TK)	5475	16425
Total Fuel Saves per year (TK)	10950	0

Table 5.4: Fuel consumption

Estimated savings in constant costs when using ETC method instead of traditional system:

Item	Meghna bridge (ETC Sytem)	Meghna Bridge (Manual System)
Number of staff in toll collection system	32	80
Annual extra income of an employee in toll collection system	0	15000
Average personal costs in traditional system	0	200
Annual savings due to personnel costs	2400	0
Constant average cost including ticket issuing as per day	0	2000

Table 5.4.1: Cost saving

Estimated passenger time savings when using ETC method instead of traditional system:

Item	Meghna bridge (ETC System)	Meghna Bridge (Manual System)
Total reduced time per day (Seconds)	48520	0
Total annual reduced time (Seconds)	17709800	0
Average number of passengers per vehicle	2	2
Total annual reduced time for passengers of a vehicle (Seconds)	35419600	0

Table 5.4.2: Total savings

The above benefits mentioned in this paper are related to direct payments. However, ETC systems have some indirect benefits such as air pollution reduction and environmental effects that resulting in a healthier environment and reduction of hygienic costs. One of the important advantages is longer vehicle life, reduction of transportation costs due to less travel time, increased monitoring capability and highway traffic control, increased precision of surveying activities in highways.

Time Saving Per Year		Fuel Saving Per Year		Savings from Man Power Per Year		Personal Saving of owner Per Year	
MTC Time	ETC Time	Manual Fuel Use	ETC Fuel Use	Manual Average Salary of Employee	ETC Average Salary of Employee	Manual Average Costs	ETC Average Costs
1338860880432 (Hour)	446286957120 (Hour)	1593882 (liter)	531294 (liter)	9600000 (TK)	3840000 (TK)	2400 (TK)	0 (TK)
Total Time Saving	892573923312 (Hour)	Total Fuel Saving	1062588 (liter)	Total Taka Savings	5760000 (TK)	Total Savings	2400 (TK)
Taka	0	Taka	106258800	Taka	5760000	Taka	2400

Table 5.4.3: Per Year Savings in Taka

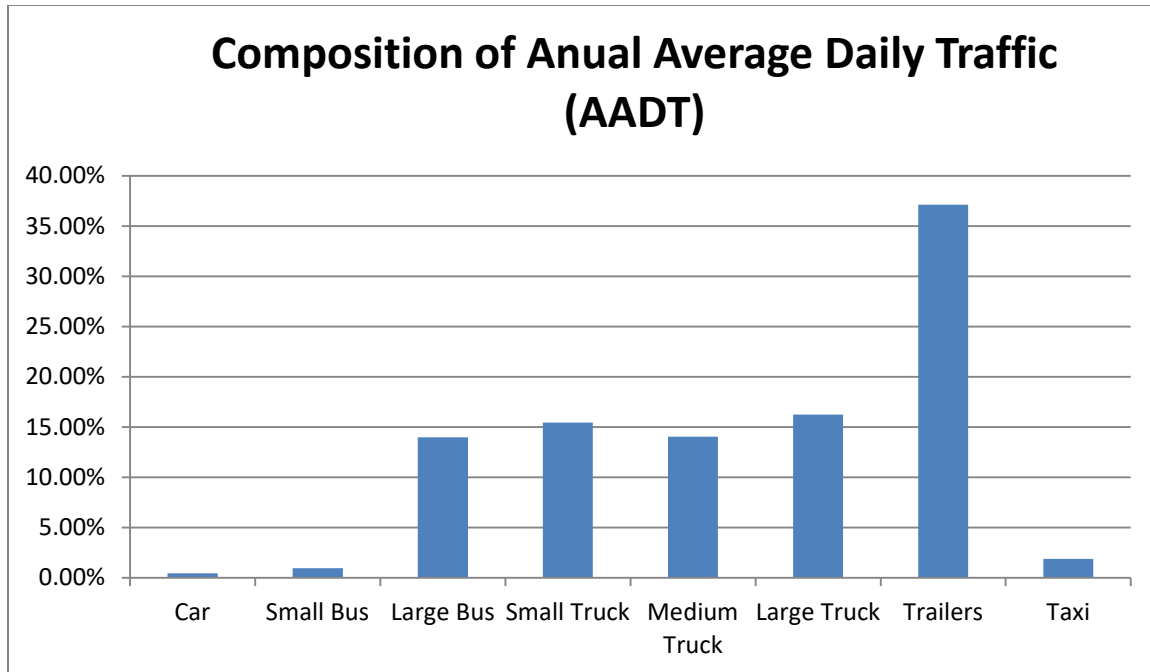
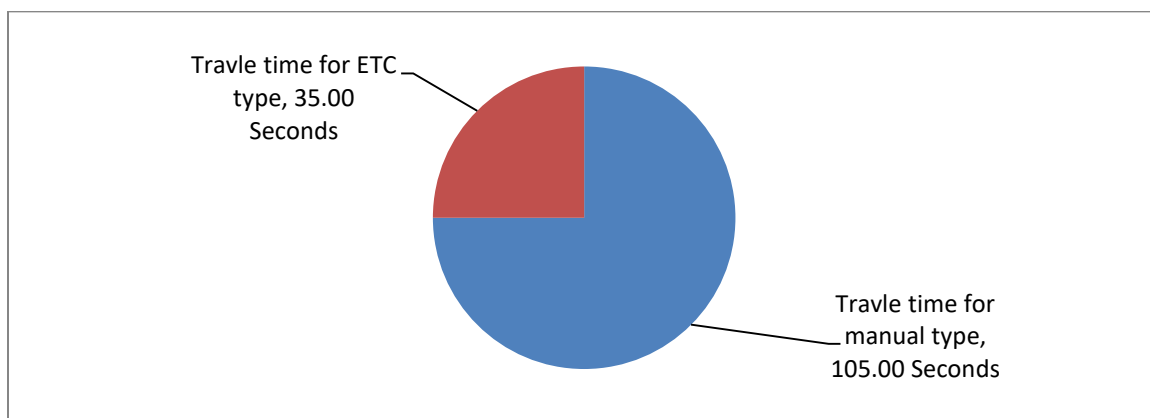

Figure 5.4: Composition of various types of vehicle

From the figure we can find that trailers/ lorry are the major shareholder of the road which is about 37% followed by large truck with 16.22% and small truck by 15.42%. It is because of the highway road. Meghna Bridge is the main road to connect with the port city of Bangladesh, from where many exported items are brought to Dhaka with the help of trailers and various types of small or large trucks. Buses are also not less in amount which indicates that people also use this road very frequently.

Time saving has been calculated in upper tables. Due to lack of information in case of Bangladesh, a value for time of different people traveling through various types of vehicles was assumed as an approximate value.



5.4.1. Figure: Travel time output for manual and ETC system

Chapter 6

Plan and Budget

6.1. Plan for proto type

6.1.1. Timeline of proto type

Calendar 2016											
JAN	FEB	MAR	APR	MAY	JUN	JUL	AUG	SEP	OCT	NOV	DEC
1. Read and Search information about RFID 2. Identifying project objectives 3. Searching for materials 4. Gathering ideas for designing											
				1. Full design of project 2. Working on Arduino 3. Writing codes 4. Components gathering for set up of the proto type							
								1. Completing full proto type 2. Simulating all codes and merging with hardware 3. Writing the book 4. Presentation			

Table 6.1: Timeline of proto type

6.1.2. Budget for proto type

Number	Components	Price (Tk)
1	Arduino Mega R3 2560	4591.56
2	Load Cell 5 kg	900.01
3	HX-711 Load Cell Amplifier	800
4	Buzzer 5v	20
5	5mm LED	600
6	Jumper Wires	266.15
7	RC-522 13.56 Mhz RFID Reader	3600
8	Servo SG-91	306.45
9	LCD Display (16*2)	205.88
10	SIM900A Kit	2176.70
11	GSM Module	966.67
12	4 Car	2000
13	Base + Road construction	2500
14	Project book (5 copies)	1000
	Total	19,933.42

Table 6.1.2: Proto type full cost

6.2. Plan for original type

6.2.1. Timeline of original type

Calendar						
JAN	FEB	MAR	APR	MAY	JUN	JUL
1. Testing all feasibility						
2. Buying all components						
3. Arranging full software and codes for larger scale						
4. Import heavy weight sensor						

	<ol style="list-style-type: none"> 1. Implementing all the components 2. Setting up RFID tags, servo motor, weight sensors etc 3. Merging components and software together simultaneously 	
		<ol style="list-style-type: none"> 1. Full simulation 2.Reducing all errors by trail and test basis 3. Project handover

Table 6.2.1: Timeline of original project

6.2.2. Budget for original type

Number	Components	Price (Tk)
1	4 Arduino Mega R3 2560	18366.24
2	Weight Sensor 200 Ton	103714.06
3	Wires	10000
4	RFID Readers	117750
5	4 LCD Digital Display 21 inch	120000
6	GSM module	4500
7	Motor	25000
8	Base + Road construction	400000
9	Taxes due to purchases of components	50000
	Total	8,49,330.3

Table 6.2.2: Original project cost

Chapter 7

Conclusion and Future Ideas

7.1. Conclusion

After doing study on this project it is found that introduction of ETC system can be beneficial for the country and its people. The main benefits are time consuming, fuel savings and traffic reducing. It has also the best benefit which is government is not losing any revenue from toll collection. Moreover the extra option of weight sensor will always help the bridge to avoid any kind of unwanted accidents like bridge collapse. Full safety of bridge will maintain by this weight sensor. People will also get lots of benefits among them the main benefit is fractional part of toll charge will deduct as fraction value. So no chances of people paying a round figure amount for fraction value. As it is one of the main high way road for connecting to port city of Bangladesh which is Chittagong, so lots of export and import products passes by this road. The traffic free toll system will add a good impression to those people and they can enjoy the travel on this road by short time. GSM module will send message to the phone, so the passenger will know how much he has paid for toll and no chance of charging extra money. The main objective of this project is dealing with RFID tags and keeping all the vehicles under registration, so that no unregistered car can be used and do unethical works against law.

7.2. Future ideas

1. Smart road system using speed meter

In our country road accidents are too common now a day. This accidents one of the main reason is high speed. If people would limit their speed according by the speed meter than 90% of accident can be reduced. So in high ways this speed meter can give all the vehicles users a proper guideline of speed limiting. Moreover it can also have an extra application like if any vehicle goes beyond the speed limit which it is not suppose to then this speed meter will trace that vehicle.

2. Develop a dynamic system for ETC conversion

In our research the number of ETC lanes and their time of implementation are decided based on the delays at the ETC lane and the value of the benefits. Thus an algorithm can be developed to decide upon the optimum number of ETC lanes as compared to the manual and automatic

lanes and also take into account the lane type that needs to be converted in order to maximize the benefits and reduce the delays at the toll plaza.

3. Alerting the passenger before his account come to a minimum amount

In our project we are showing 3 cases of toll payment those are having sufficient balance in account, having zero amounts and having marginal amount. In those cases having zero amounts will make the system manual, so it's better to send them alert message before going through to the minimum amount.

4. A full database and image processing system

In our project we are saving all the records in a memory card, but if it can be saved in a full database system with all the respective records of each vehicles with image processing then it can give a biggest security to the government. This record can help government to trace any culprit using this road.

References

1. KhadijahKamarulazizi and DR. Wadad Ismail, “Electronic toll collection system using passive RFID technology”, School of Electrical and Electronic, University Science Malaysia, Journal of Theoretical and Applied Information Technology, 2005-2010
2. Ganesh K. Andurkar and Vidya R. Ramteke, “Smart highway Electronic Toll Collection system”, International Journal of Innovative Research in Computer and Communication Engineering, Vol. 3, Issue 5, May 2015
3. Md. Saidul Hoque, Md. Jawed Alam, Md. Akbar Hossain Patwary, A.S.M. Elias Shah, A.H.M. Javed Hossain Talukdar, Mobashera Sadia Haque and Md. Shahriar Rahman Khan, Roads and Highways Department, Dhaka-1000, Bangladesh, Masaaki Tatsumi and Prosenjit Kumar Ghosh, Oriental Consultants Global Co. Ltd., Tokyo-151-0071, Japan, “Three 2nd bridges construction and existing bridges rehabilitation under KMG project, IABSE-JSCE Joint conference on Avances in Bridge Eeineering-III, August 21-22, 2015
4. David Levinson and Elva Chang, “A Model for Optimizing Electronic Toll Collection Systems”, Department of Civil Engineering, University of Minnesota, Transportation Research Part A 37 (2003) 293-314, Received 6 September 1999; received in revised form 12 February 2002; accepted 19 February 2002
5. Priyanka Sharma and Vivek Sharma ,“Electronic toll collection technologies: A state of art review” , an International Journal of Advanced Research in Computer Science and Software Engineering, Volume 4, Issue 7, July 2014, pp. 621-625
6. Abdalla Mohammed Mohammed, Maryse Mamdouh Naguib Fahmy Nashed, Michael Essam Amin Nasr, Mohammed Gamal El Prince and Nour El Din Mohammed Nour El Din, “Information and Communication Technologies Engineering Smart Road System”, Uninettuno University – Helwan University, 3 August 2011
7. Mohmoud Saffarzadeh and Abdolreza Rezaee-Arjroody, “Cost-Benefit Analysis of Electronic Toll Collection (ETC) System in Iranian Freeways”, Case Study: Tehran-QOM Freeway, PIARC International Seminar on Intelligent Transport System (ITS) In Road Network Operations, August16, 2016

Appendix

Appendix A

Arduino Code:

```
#include "HX711.h"

#include <GSM.h>

#include <Servo.h>

#include <SPI.h>

#include <MFRC522.h>

#include <LiquidCrystal.h>

LiquidCrystal lcd(9, 8, 7, 6, 5, 4);

String p_a = "Total bus toll = ";

String p_b = " Total car toll = ";

String p_c = " Total cng toll = ";

String p_d = " Total Toll In One Day = ";

String Print;

int pushButton = 22;

int B = 10;

int total_toll = 0;

int money = 0;

// for printing

int total_bus = 0;

int total_car = 0;

int total_cng = 0;
```

```

int account;

int toll;

intbus_money = 1000;

intruck_money = 1000;

intcar_money = 1000;

intcng_money = 0;

constintbus_toll = 200;

constintruck_toll = 300;

constintcar_toll = 100;

constintcng_toll = 50;

// HX711.DOUT - pin #A1

// HX711.PD_SCK - pin #A0

HX711 scale(A1, A0);

int weight;

char Phn_no_bus[] = "01670497086"; // Mustafa

char Phn_no_truck[] = "01680067832"; // Jubidur

char Phn_no_car[] = "01786491225"; // Nitol

char Phn_no_cng[] = "01860558212"; // Mahmud

char text[200] ;

char phn_no[16] ;

char text_1[] = "Dear user, your toll bill is " ;

char text_2[] = " Your remaining balance is" ;

char text_3[] = "Dear user, you can not pass because Your vehicle's weight is ";

char text_4[] = " which crosses the weight limit." ;

char dot[] = "." ;

```

```

#define PINNUMBER ""

GSM gsmAccess;

GSM_SMS sms;

#define RST_PIN    48

#define SS_PIN     53

MFRC522 mfrc522(SS_PIN, RST_PIN);

int vehicle;

intvehicle_type;

Servo myservo;

void setup() {

// put your setup code here, to run once:

//Serial.begin(9600);

lcd.begin(16, 2);

myservo.attach(2);

// setup_rfid();

SPI.begin();

mfrc522.PCD_Init();

//setup_hx711();

Serial.begin(115200);

//Serial.println("HX711 Demo");

//Serial.println("Before setting up the scale:");

//Serial.print("read: \t\t");

//Serial.println(scale.read()); // print a raw reading from the ADC

//Serial.print("read average: \t\t");

```

```

//Serial.println(scale.read_average(20)); // print the average of 20 readings from the ADC

//Serial.print("get value: \t\t");

//Serial.println(scale.get_value(5)); // print the average of 5 readings from the ADC minus the
tare weight (not set yet)

// Serial.print("get units: \t\t");

//Serial.println(scale.get_units(5), 1); // print the average of 5 readings from the ADC minus tare
weight (not set) divided

    // by the SCALE parameter (not set yet)

scale.set_scale(2280.f);          // this value is obtained by calibrating the scale with known
weights; see the README for details

scale.tare();          // reset the scale to 0

// Serial.println("After setting up the scale:");

//Serial.print("read: \t\t");

//Serial.println(scale.read());          // print a raw reading from the ADC

//Serial.print("read average: \t\t");

// Serial.println(scale.read_average(20)); // print the average of 20 readings from the ADC

// Serial.print("get value: \t\t");

//Serial.println(scale.get_value(5)); // print the average of 5 readings from the ADC minus the
tare weight, set with tare()

//Serial.print("get units: \t\t");

//Serial.println(scale.get_units(5), 1); // print the average of 5 readings from the ADC minus
tare weight, divided

    // by the SCALE parameter set with set_scale

//Serial.println("Readings:");

//setup_gsm();

```



```

//while (!Serial) {

//; // wait for serial port to connect. Needed for native USB port only

//}

//Serial.println("SMS Messages Sender");

booleannotConnected = true;

// Start GSM shield

// If your SIM has PIN, pass it as a parameter of begin() in quotes

//while (notConnected) {

//if (gsmAccess.begin(PINNUMBER) == GSM_READY) {

//notConnected = false;

//Serial.println("Connected");

//} else {

//Serial.println("Not connected");

//delay(1000);

//}

//}

delay(3000);

pinMode(pushButton, INPUT);

pinMode(B, OUTPUT);

digitalWrite(B, LOW);

myservo.write(180);

lcd.setCursor(0, 0);

lcd.print("WELCOME !");

//Serial.println("Ready ");

//Serial.println("READY");

```

```

delay(1000);
}
void loop() {
// put your main code here, to run repeatedly:
get_weight();
//Serial.println(weight);
get_vehicle_type();
if (weight < 4)
{
if (vehicle_type == 1)
{
//Serial.println("Bus");
//delay(3000);
account = bus_money ;   /// for updating Money info
toll = bus_toll ;
update_rem_money();
bus_money = account;
T_toll(total_toll, bus_toll);
total_bus = total_bus + 1;
sprintf(text, "%s %i%s %s %i%s", text_1, bus_toll, dot, text_2, bus_money, dot);
sprintf(phn_no, "%s", Phn_no_bus);
//send_sms();
lcd_print_pass();
door_open();
print_to();

```

```

}

    else if (vehicle_type == 3) // Car
    {
        //Serial.println("car");

        account = car_money ; // Updating Account

        toll = car_toll ;

        update_rem_money();

        car_money = account ;

        total_car = total_car + 1;

            /// SMS sending

        sprintf(text,"%s %i%s %s %i%s",text_1,car_toll,dot,text_2,car_money,dot);

        sprintf(phn_no,"%s",Phn_no_car);

        //send_sms();

        lcd_print_pass();

        door_open();

        print_to();

    }

    else if (vehicle_type == 4) // CNG

    {

        /*account = cng_money ; // updating account

        toll = cng_toll ;

        update_rem_money();

        cng_money = account ; */

        // Serial.println("CNG");

```

```

    /// SMS sending

    char text_5[] = "Dear user, you can not pass because You have insufficient balance. Please Pay
    Manually to pass.";

    sprintf(text,"%s",text_5);

    sprintf(phn_no,"%s",Phn_no_cng);

    //send_sms();

    lcd_print_not_pass();

    while(1)
    {
        if (digitalRead(pushButton) == HIGH)
        {
            char text_6[] = "Dear user, you can pass now. Your manual transection has been successful.";

            sprintf(text,"%s",text_6);

            sprintf(phn_no,"%s",Phn_no_cng);

            //send_sms();

            account = car_money ; // Updating Account

            toll = cng_toll ;

            update_rem_money();

            cng_money = account ;

            total_cng = total_cng + 1;

            //Serial.println("Manual Transection Done");

            lcd_print_pass();

            door_open();

            print_to();

            break;

```

```

}
else
{
//Serial.println("Waiting for Manual Transection..."); // do nothing
}
}
}
}
else
{
//Serial.println("truck");
//delay(3000);
sprintf(text, "%s %i%s", text_3, weight, text_4, dot);
sprintf(phn_no, "%s", Phn_no_truck);
//send_sms();
lcd_print_not_pass();
delay(2000);
}
vehicle_type = 0;
}
void setup_gsm()
{
while (!Serial) {
// wait for serial port to connect. Needed for native USB port only
}
}

```

```

//Serial.println("SMS Messages Sender");

// connection state
boolean notConnected = true;

// Start GSM shield

// If your SIM has PIN, pass it as a parameter of begin() in quotes
while (notConnected) {

if (gsmAccess.begin(PINNUMBER) == GSM_READY) {

notConnected = false;

} else {

//Serial.println("Not connected");

delay(1000);

}

// Serial.println("Ready ");

delay(3000);

}

//Serial.println("GSM initialized");

}

/* void send_sms()

{

while(i==1)

{

sms.beginSMS(phn_no);

sms.print(text);

sms.endSMS();

//Serial.println("\nCOMPLETE!\n");

```

```

i=i-1;

Serial.println("SMS sent");
}
} */

void setup_hx711()
{
Serial.begin(38400);

//Serial.println("HX711 Demo");

//Serial.println("Before setting up the scale:");

//Serial.print("read: \t\t");

//Serial.println(scale.read()); // print a raw reading from the ADC

//Serial.print("read average: \t\t");

//Serial.println(scale.read_average(20)); // print the average of 20 readings from the ADC

//Serial.print("get value: \t\t");

//Serial.println(scale.get_value(5)); // print the average of 5 readings from the ADC minus the
tare weight (not set yet)

// Serial.print("get units: \t\t");

//Serial.println(scale.get_units(5), 1); // print the average of 5 readings from the ADC minus tare
weight (not set) divided

// by the SCALE parameter (not set yet)

scale.set_scale(2280.f); // this value is obtained by calibrating the scale with known
weights; see the README for details

scale.tare(); // reset the scale to 0

// Serial.println("After setting up the scale:");

//Serial.print("read: \t\t");

//Serial.println(scale.read()); // print a raw reading from the ADC

```

```

//Serial.print("read average: \t\t");

// Serial.println(scale.read_average(20));    // print the average of 20 readings from the ADC

// Serial.print("get value: \t\t");

//Serial.println(scale.get_value(5)); // print the average of 5 readings from the ADC minus the
tare weight, set with tare()

//Serial.print("get units: \t\t");

//Serial.println(scale.get_units(5), 1);    // print the average of 5 readings from the ADC minus
tare weight, divided

        // by the SCALE parameter set with set_scale

//Serial.println("Readings:");

}

void get_weight()

{

weight = scale.get_units();

weight= map(weight, -100, 0, 5, 1);

delay(100);

}

void get_vehicle_type()

{

RfidScan();

    if (vehicle==38){

//      Serial.println("success");

vehicle_type = 1;

    }

    else if(vehicle==254){

vehicle_type = 2;

```



```

}
else if (vehicle==103){
//      Serial.println("success");
vehicle_type = 3;
}
else if(vehicle==22){
vehicle_type = 4;
}
vehicle = 0;
}
void door_open()
{
myservo.write(90);
delay(10000);
digitalWrite(B, HIGH);
myservo.write(180);
digitalWrite(B, LOW);
delay(200);
}
void dump_byte_array(byte *buffer, byte bufferSize) {
for (byte i = 0; i <bufferSize; i++) {
//Serial.print(buffer[i] < 0x10 ? " 0" : " ");
//Serial.println(buffer[i], DEC);
}
vehicle=buffer[0];

```

```

}
void RfidScan()
{
if ( ! mfrc522.PICC_IsNewCardPresent())
return;
if ( ! mfrc522.PICC_ReadCardSerial())
return;
dump_byte_array(mfrc522.uid.uidByte, mfrc522.uid.size);
}
void update_rem_money() // updating account for the toll
{
account = account-toll;
}
void lcd_print_pass()
{
lcd.setCursor(0, 0);
lcd.print("WELCOME !");
lcd.setCursor(0, 1);
lcd.print("YOU CAN PASS");
delay(2500);
lcd.clear();
lcd.setCursor(0, 0);
lcd.print("WELCOME !");
delay(500);
}

```

```

void lcd_print_not_pass()
{
lcd.setCursor(0, 0);
lcd.print("WELCOME !");
lcd.setCursor(0, 1);
lcd.print("YOU CAN'T PASS");
delay(2500);
lcd.clear();
lcd.setCursor(0, 0);
lcd.print("WELCOME !");
delay(500);
}

void send_sms()
{
while (1)
{
sms.beginSMS(phn_no);
sms.print(text);
sms.endSMS();

//Serial.println("\nSMS sent!\n");

break;
}

delay(1000);
}

void T_toll(inttotal_toll, int money)

```

```
{
total_toll = total_toll + money;
return total_toll;
}

void print_to()
{
int a = bus_toll*total_bus;
int b = car_toll*total_car;
int c = cng_toll*total_cng;

String p_aa = p_a + String(bus_toll*total_bus);
String p_ab = p_b + String(car_toll*total_car);
String p_ac = p_c + String(cng_toll*total_cng);
total_toll = a+b+c;

String p_ad = p_d + String(total_toll);

Print = p_aa +p_ab + p_ac + p_ad;
Serial.println(Print);
}
```

Appendix B

Python Code:

```
import time
import datetime
import serial
import msvcrt

a=datetime.datetime.now()
b=str(a)

name = str(a.year)+","+str(a.month)+","+str(a.day)+".txt"
arduino = serial.Serial('COM4',115200)

i = 0

#while True:

# print (arduino.readline())

#

# time.sleep(1)

while i<4:

file = open(name, "w")

data = str(arduino.readline())

print (data)

file.write(data)

    i= i+1

file.close()

file.close()

arduino.close()
```