

**[Performance analysis of MULTI-CARRIER
Direct Sequence CDMA with fading (Rayleigh
and Rician)]**



[Thesis]

**PERFORMANCE ANALYSES OF
A MULTI-CARRIER CODE DIVISION CDMA WIRELESS
COMMUNICATION SYSTEM
WITH FADING (Rayleigh and Rician)**

Thesis Report

Summer 2010

Prepared by,

Saad Mahmood- 06310033

M.M. Wasid Hossain-07110104

Abu Sakib Abdullah-07110056

A Thesis under Supervision of **Dr.Satya Prasad Majumder**

In Partial Fulfillment of the Requirements for the Degree

of

Bachelor of Science in Electronics and Communication Engineering

Department of Electronics and Electrical Engineering

(Electronics and Communication Engineering Program)



BRAC University, Dhaka, Bangladesh

Table of Contents

Chapter One: Introduction

1.1 Introduction to Wireless Communication

1.2 Multiple Access technologies

1.2.1 Frequency Division Multiple Accesses (FDMA)

1.2.2 Time Division Multiple Access (TDMA)

1.2.3 Code Division Multiple Access (CDMA)

1.2.3.1 Direct Sequence Code Division Multiple Access (DS-SS)

1.2.3.2 Frequency Hopping Code Division Multiple Access (FH-SS)

1.2.4 Limitations

1.2.4.1 Fading

1.2.4.2 Delay spread

1.3 Objectives

Chapter Two: System Model of MC CDMA

2.1 Multi Carrier Code Divisions Multiple Accesses (MC-SS)

2.2 Direct Sequence Code Division Multiple Access (DS-SS)

2.3 Multi Carrier Direct Sequence Code Division Multiple Access (MC DS SS)

2.4 Comparison of the Spreading codes in all SS techniques

Chapter Three: Analysis of MC DS SS

3.1 Expression of Multi Access Interference (MAI)

Chapter Four: Results & Discussion

- 4.1 Plots fo simple SIR vs. j
- 4.2 Plots of SIR vs. j (with value of Nc)
- 4.3 Plots of SIR vs. j (cut from 10db)
- 4.4 Plots of Nc vs j
- 4.5 Plots of simple SIRdb vs. Ps
- 4.6 Plots of SIRdb vs. Ps (with value j)
- 4.7 Plots of SIRdb vs. Ps (cut from -7)
- 4.8 Plots of Ps vs. j (SIRdb = -7)
- 4.9 Plots of ICI vs. j
- 4.10 Plots of ICI vs. j (with value alpha)
- 4.11 Plots of ICI vs. j (cut from ICI = 10^5)
- 4.12 Plots of alpha vs. j
- 4.13 Plots of berdb vs. Ps
- 4.14 Plots of berdb vs. Ps (with value of alpha)
- 4.15 Plots of berdb vs. Ps (cut berdb from -4)
- 4.16 Plots of Ps vs. alpha
- 4.17 Plots of BER vs. Nu
- 4.18 Plots of BER vs. Nu (with value of Nc)
- 4.19 Plots of BER vs. Nu (cut BER from 10^{-15})
- 4.20 Plots of Nu vs. Nc

Chapter Five: Conclusion and Future work on MC DS CDMA with Fading

- 5.1 Conclusion
- 5.2 Future Works:
- 5.3 Reference

CHAPTER 1

Introduction

1.1 Introduction to Wireless Communication:

Wireless communication is the transfer of information over a distance without the use of electrical conductors or "wires". The distances involved may be short (a few meters as in television remote control) or long (thousands or millions of kilometers for radio communications). When the context is clear, the term is often shortened to "wireless". Wireless communication is generally considered to be a branch of telecommunications.

It encompasses various types of fixed, mobile, and portable two-way radios, cellular telephones, personal digital assistants (PDAs), and wireless networking. Other examples of include GPS units, garage door openers and or garage doors, wireless computer mice, keyboards and headsets, television and cordless telephones.

Wireless operations permits services, such as long range communications, that are impossible or impractical to implement with the use of wires. The term is commonly used in the telecommunications industry to refer to telecommunications systems (e.g. radio transmitters and receivers, remote controls, computer networks, network terminals, etc.) which use some form of energy (e.g. radio frequency (RF), infrared light, laser light, visible light, acoustic energy, etc.) to transfer information without the use of wires. Information is transferred in this manner over both short and long distances.

Radio transmission through the air. Wireless is a very generic term that refers to numerous forms of transmission that do not use metal wires or optical fibers. They include AM and FM radio, TV, cell phones, portable phones and wireless LANs. Various techniques are used to provide wireless transmission, including infrared line of sight, cellular, microwave, satellite, packet radio and spread spectrum. See network, cellular, wireless glossary, wireless LAN, CMRS, PCS, FDMA, TDMA, CDMA and CDPD.

1.2 Multiple Access technologies:

Multiple Accesses is a technique where many subscribers or local stations can share the use of the use of a communication channel at the same time or nearly so despite the fact originate from widely different locations. A channel can be defined as a portion of the limited radio resource, which is temporarily allocated for a specific purpose or user, such as someone's phone call. A multiple access method is a definition of how the radio spectrum is divided into channels and how the channels are allocated to the many users of the system. There are three basic techniques of multiple accesses.

- Frequency Division Multiple Access (FDMA)
- Time Division Multiple Access (TDMA)
- Code Division Multiple Access (CDMA)]

In telecommunications and computer networks, a channel access method or multiple access method allows several terminals connected to the same multi-point transmission to transmit over it and to share its capacity. Examples of shared physical media are wireless networks, bus networks, ring networks, hub networks and half-duplex point-to-point links.

A channel-access scheme is based on a multiplexing method, that allows several data streams or signals to share the same communication channel or physical medium. Multiplexing is in this context provided by the physical layer. Note that multiplexing also may be used in full-duplex point-to-point communication between nodes in a switched network, which should not be considered as multiple accesses.

A channel-access scheme is also based on a multiple access protocol and control mechanism, also known as media access control (MAC). This protocol deals with issues such as addressing, assigning multiplex channels to different users, and avoiding collisions. The MAC-layer is a sub-layer in Layer 2 (Data Link Layer) of the OSI model and a component of the Link Layer of the TCP/IP model.

1.2.1 Frequency Division Multiple Accesses (FDMA):

Frequency Division Multiple Access or FDMA is a channel access method used in multiple-access protocols as a channelization protocol. FDMA gives users an individual allocation of one

or several frequency bands, or channels. Multiple Access systems coordinate access between multiple users. The users may also share access via different methods such as TDMA, CDMA, or SDMA. These protocols are utilized differently, at different levels of the theoretical OSI model.

Disadvantage: Crosstalk which causes interference on the other frequency and may disrupt the transmission.

Features

- FDMA requires high-performing filters in the radio hardware, in contrast to TDMA and CDMA.
- FDMA is not vulnerable to the timing problems that TDMA has. Since a predetermined frequency band is available for the entire period of communication, stream data (a continuous flow of data that may not be packetized) can easily be used with FDMA.
- Due to the frequency filtering, FDMA is not sensitive to near-far problem which is pronounced for CDMA.
- Each user transmits and receives at different frequencies as each user gets a unique frequency slot

It is important to distinguish between FDMA and frequency-division duplexing (FDD). While FDMA allows multiple users simultaneous access to a certain system, FDD refers to how the radio channel is shared between the uplink and downlink (for instance, the traffic going back and forth between a mobile-phone and a base-station). Furthermore, frequency-division multiplexing (FDM) should not be confused with FDMA. The former is a physical layer technique that combines and transmits low-bandwidth channels through a high-bandwidth channel. FDMA, on the other hand, is an access method in the data link layer.

FDMA also supports demand assignment in addition to fixed assignment. *Demand assignment* allows all users apparently continuous access of the radio spectrum by assigning carrier frequencies on a temporary basis using a statistical assignment process. The first FDMA *demand-assignment* system for satellite was developed by COMSAT for use on the *Intelsat* series IVA and V satellites.

1.2.2 Time Division Multiple Access (TDMA):

Time division multiple access (TDMA) is a channel access method for shared medium networks. It allows several users to share the same frequency channel by dividing the signal into different time slots. The users transmit in rapid succession, one after the other, each using his own time slot. This allows multiple stations to share the same transmission medium (e.g. radio frequency channel) while using only a part of its channel capacity. TDMA is used in the digital 2G systems such as Global System for Mobile Communications (GSM), IS-136, Personal Digital Cellular (PDC) and iDEN, and in the Digital Enhanced Cordless Telecommunications (DECT) standard for portable phones. It is also used extensively in satellite systems, and combat-net radio systems. For usage of Dynamic TDMA packet mode communication, see below.

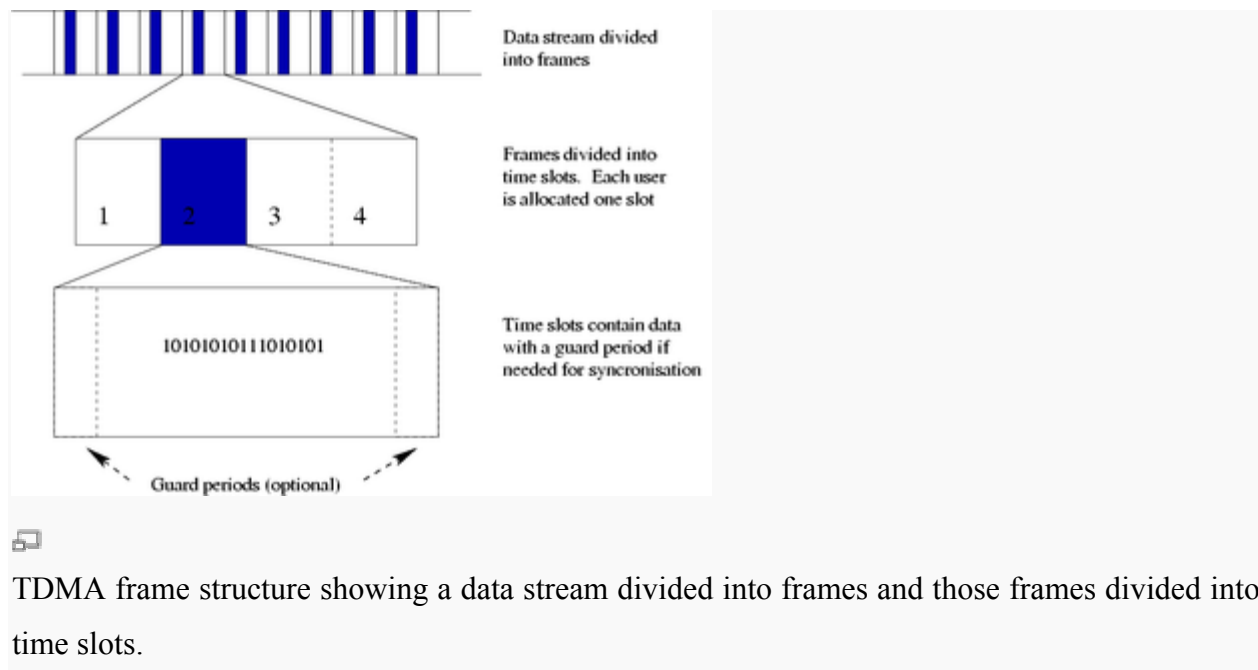

TDMA is a type of Time-division multiplexing, with the special point that instead of having one transmitter connected to one receiver, there are multiple transmitters. In the case of the *uplink* from a mobile phone to a base station this becomes particularly difficult because the mobile phone can move around and vary the *timing advance* required to make its transmission match the gap in

1.2.3 Code Division Multiple Access (CDMA):

Code division multiple access (CDMA) is a channel access method utilized by various radio communication technologies. It should not be confused with the mobile phone standards called CDMA One and CDMA2000 (which are often referred to as simply "CDMA"), which use CDMA as an underlying channel access method.

One of the basic concepts in data communication is the idea of allowing several transmitters to send information simultaneously over a single communication channel. This allows several users to share a bandwidth of different frequencies. This concept is called multiplexing. CDMA employs spread-spectrum technology and a special coding scheme (where each transmitter is assigned a code) to allow multiple users to be multiplexed over the same physical channel. By contrast, time division multiple access (TDMA) divides access by time, while frequency-division multiple access (FDMA) divides it by frequency. CDMA is a form of spectrum "signaling, since the modulated coded signal has a much higher data bandwidth than the data being communicated.

An analogy to the problem of multiple access is a room (channel) in which people wish to communicate with each other. To avoid confusion, people could take turns speaking (time division), speak at different pitches (frequency division), or speak in different languages (code division). CDMA is analogous to the last example where people speaking the same language can understand each other, but not other people. Similarly, in radio CDMA, each group of users is given a shared code. Many codes occupy the same channel, but only users associated with a particular code can understand each other.

CDMA system is divided into two parts:

1. Direct Sequence Code Division Multiple Access (DS-CDMA)
2. Frequency Hopping Code Division Multiple Access (FH-CDMA)

1.2.3.1 Direct Sequence Code Division Multiple Access (DS-CDMA):

In Direct Sequence spread spectrum transmission, the user data signal is multiplied by a code sequence. Mostly, binary sequences are used. The duration of an element in the code is called the "chip time". The ratio between the user symbol time and the chip time is called the spread factor.

The transmit signal occupies a bandwidth that equals the spread factor times the bandwidth of the user data.

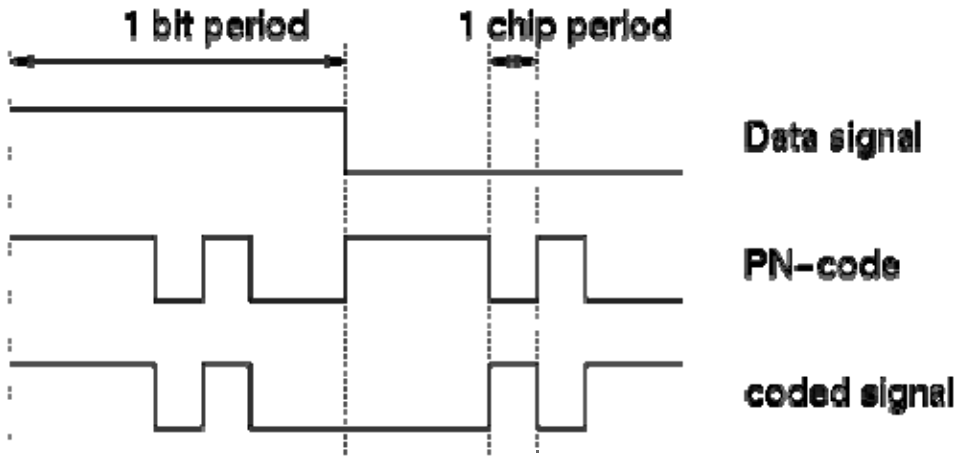
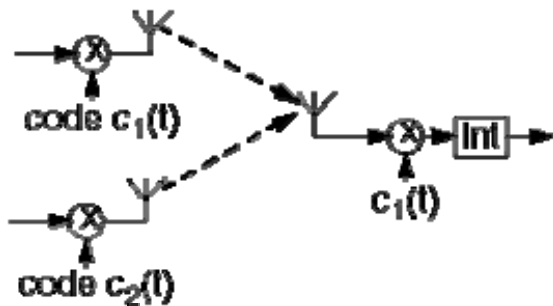

Figure 1: A DS-CDMA signal is generated by multiplication of a user data signal by a code sequence.

In the receiver, the received signal is again multiplied by the same (synchronized) code. This operation removes the code, so we recover the transmitted user data.



Different CDMA users use different codes. In this example the receiver sees the signal from user 1, while the signal from user 2 is heavily attenuated by the correlator (multiplier and integrator) in the receiver.

A CDMA receiver can retrieve the wanted signal by multiplying the receive signal with the same code as the one used during transmission. We find:

$$\sum_{n=1}^N c_1^2(nT_c + t_d) = \sum_{n=1}^N c_1^2(nT_c) = N$$

where c_1 is the code sequence used by user 1, T_c is the chip duration, t_d is a common time offset,

shared between transmitter and receiver and N is the length of the code sequence.. Note that the receive code must be perfectly time aligned with the transmit code.

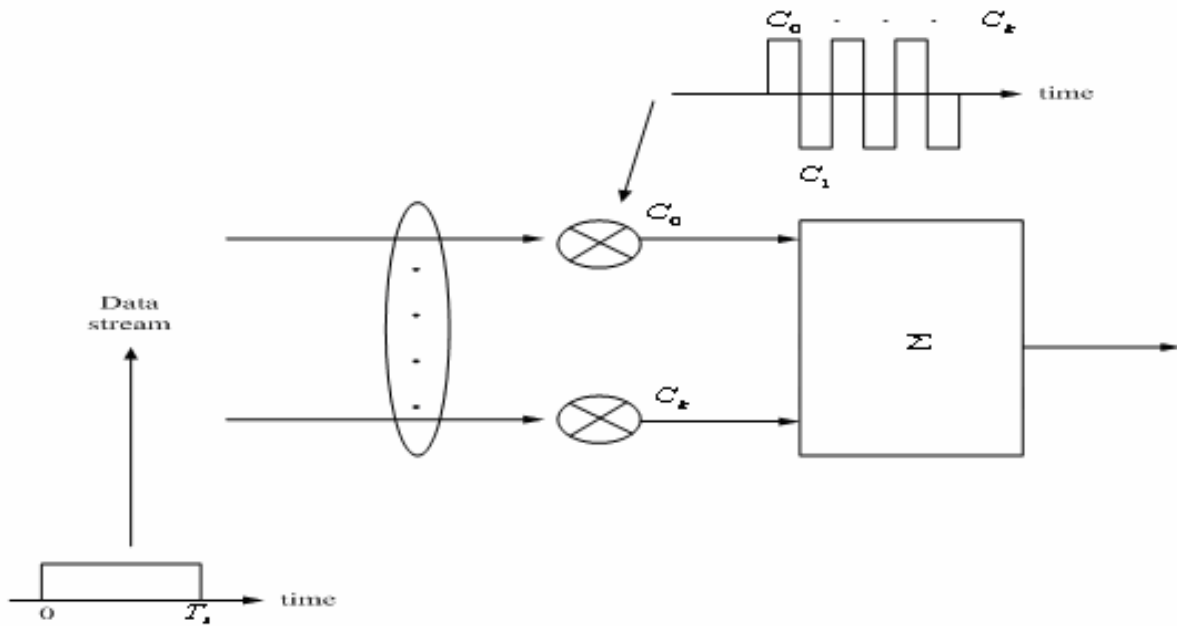

Figure 2: Transmitter of DS-CDMA

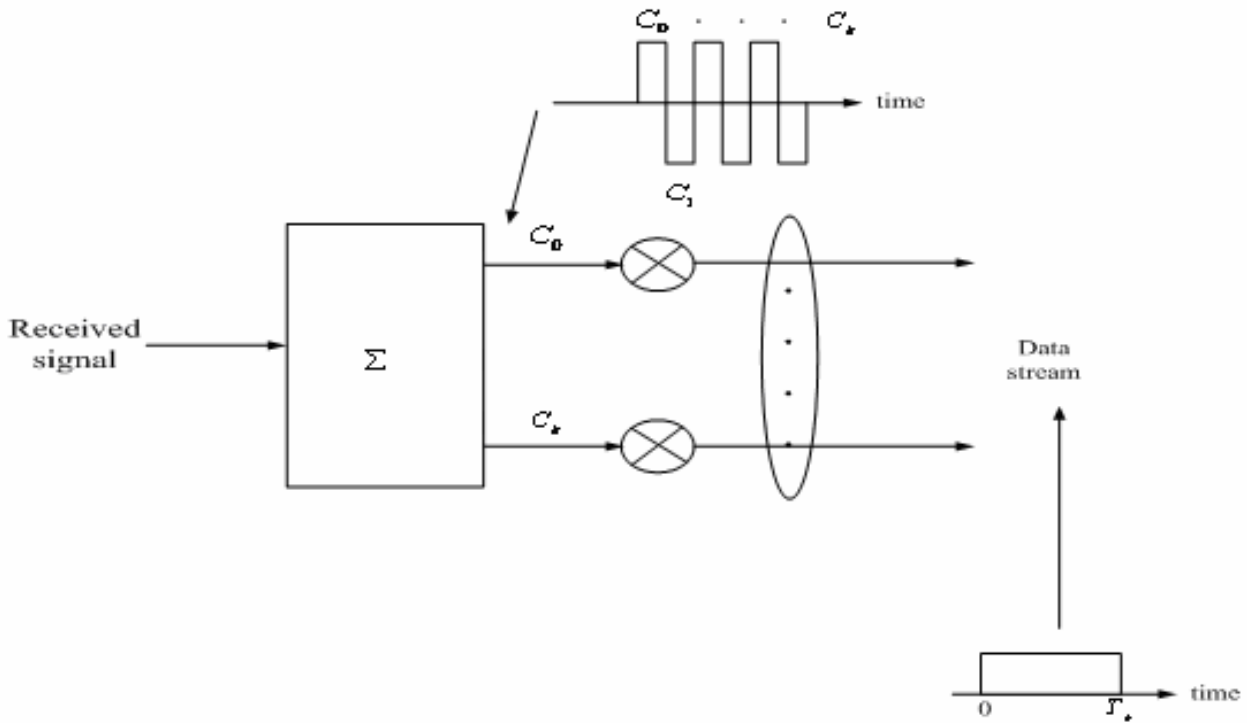

Figure 3: Receiver of DS-SS-CDMA

1.2.3.2 Frequency Hopping Code Division Multiple Access (FH-SS-CDMA):

FH – SS-CDMA is a kind of spread spectrum technology that enables many users to share the same channel by employing a unique hopping pattern to distinguish different users' transmission. The type of spread spectrum in which the carrier hops randomly from one frequency to another is called FH spread spectrum. A common modulation format for FH system is that of M-ary frequency shift keying (MFSK).

A major advantage of frequency hopping is that it can be implemented over a much larger frequency band than it is possible to implement DS- spreading, and the band can be noncontiguous. Another major advantage is that frequency hopping provides resistance to multiple – access interference while not requiring power control to prevent near – far problems. In DS – systems, accurate power control is crucial but becomes less effective as the carrier frequency is increased.

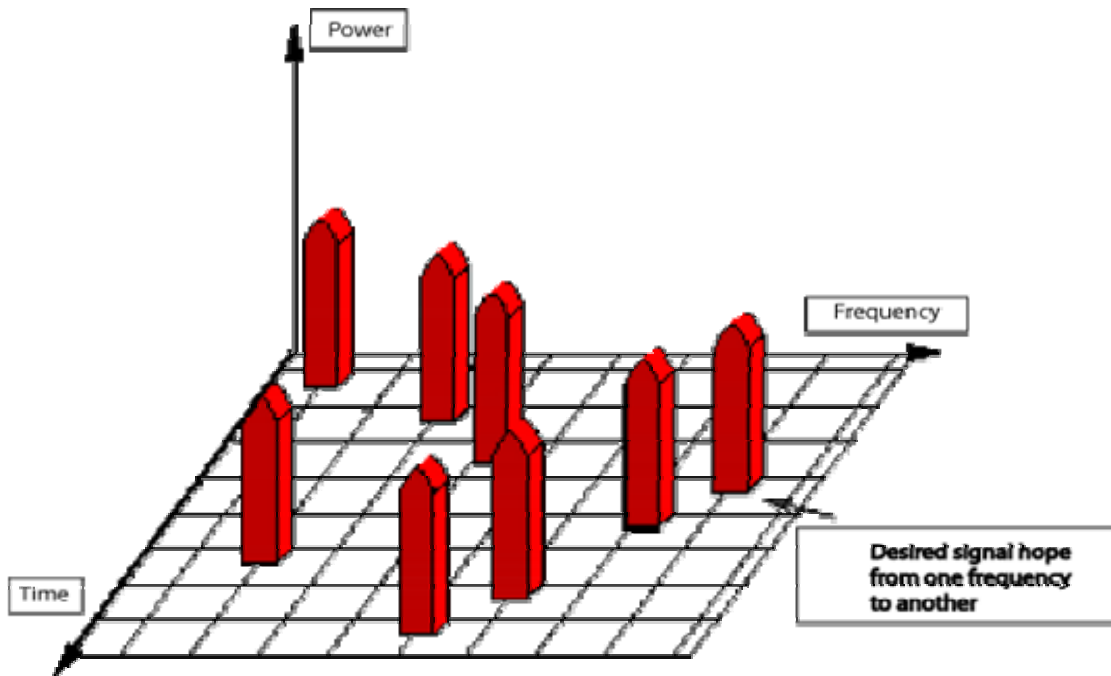

Figure 4: Frequency hopping.

Instantaneously, in frequency hopping systems, the transmitter changes the carrier frequency according to a certain hopping pattern. The advantage is that the signal sees a different channel and a different set of interfering signals during each hop. This avoids the problem of failing communication at a particular frequency. There are two basic types of frequency hopping.

Slow frequency hopping, In this case one or more data bits are transmitted within one hop. An advantage is that coherent data detection is possible. Often, systems using slow hopping also employ (burst) error control coding to restore loss of (multiple) bits in one hop.

Fast frequency hopping, In this case one data bit is divided over multiple hops. In fast hopping, coherent signal detection is difficult, and seldom used. Mostly, FSK or MFSK modulation is used.

1.2.4 Limitations:

There are some limitations in multiple access technology. They are discussed in below:

1.2.4.1 Fading:

In wireless communications, fading is deviation of the attenuation that a carrier-modulated telecommunication signal experiences over certain propagation media. The fading may vary with time, geographical position and/or radio frequency, and is often modeled as a random process. Fading channels a communication channel that experiences fading. In wireless systems, fading May either is due to multipath propagation, referred to as multipath induced fading, or due to shadowing from obstacles affecting the wave propagation, sometimes referred to as shadow fading. Fading is two types.

Slow versus fast fading:

The terms slow and fast fading refer to the rate at which the magnitude and phase change imposed by the channel on the signal changes. The coherence time is a measure of the minimum time required for the magnitude change of the channel to become uncorrelated from its previous value.

-
- Slow fading arises when the coherence time of the channel is large relative to the delay constraint of the channel. In this regime, the amplitude and phase change imposed by the channel can be considered roughly constant over the period of use. Slow fading can be caused by events such as shadowing, where a large obstruction such as a hill or large building obscures the main signal path between the transmitter and the receiver. The amplitude change caused by shadowing is often modeled using a log-normal distribution with a standard deviation according to the log-distance path loss model.
 - Fast fading occurs when the coherence time of the channel is small relative to the delay constraint of the channel. In this regime, the amplitude and phase change imposed by the channel varies considerably over the period of use.

1.2.4.2 Delay spread:

In communications, the delay spread is a measure of the multipath richness of a channel. It measures the difference between the time of arrival of the first significant multipath component (typically the line-of-sight component) and the time of arrival of the last multipath component. It is mostly used in the characterization of wireless channels, but the same concept applies to any other multipath channel (e.g. multipath in optical fibers).

The delay spread can be characterized through different metrics, although the most common one is the root mean square (rms) delay spread.

1.3 Objectives:

In this paper our concern is find out the effect of fading in MC DS-CDMA system. Performance analysis of a multi carrier (MC) direct sequence (DS) CDMA system will be carried out including the effect of fading. In this thesis paper, our main objective is to find out the expression of Multiple Access Interference (MAI) in the process of fading and the signal to noise plus Interference ratio, analysis to evaluate the effect of fading and Inter Carrier Interference (ICI) in a MC DS CDMA wireless system, to find out the expression of Unconditional BER of MC DS CDMA system including the above system limitations, we find out the analytical results in terms of BER as a function of various system parameters using the number of carriers, code length, number of users etc and to find the optimum system design parameters.

CHAPTER 2

System Model of MC CDMA

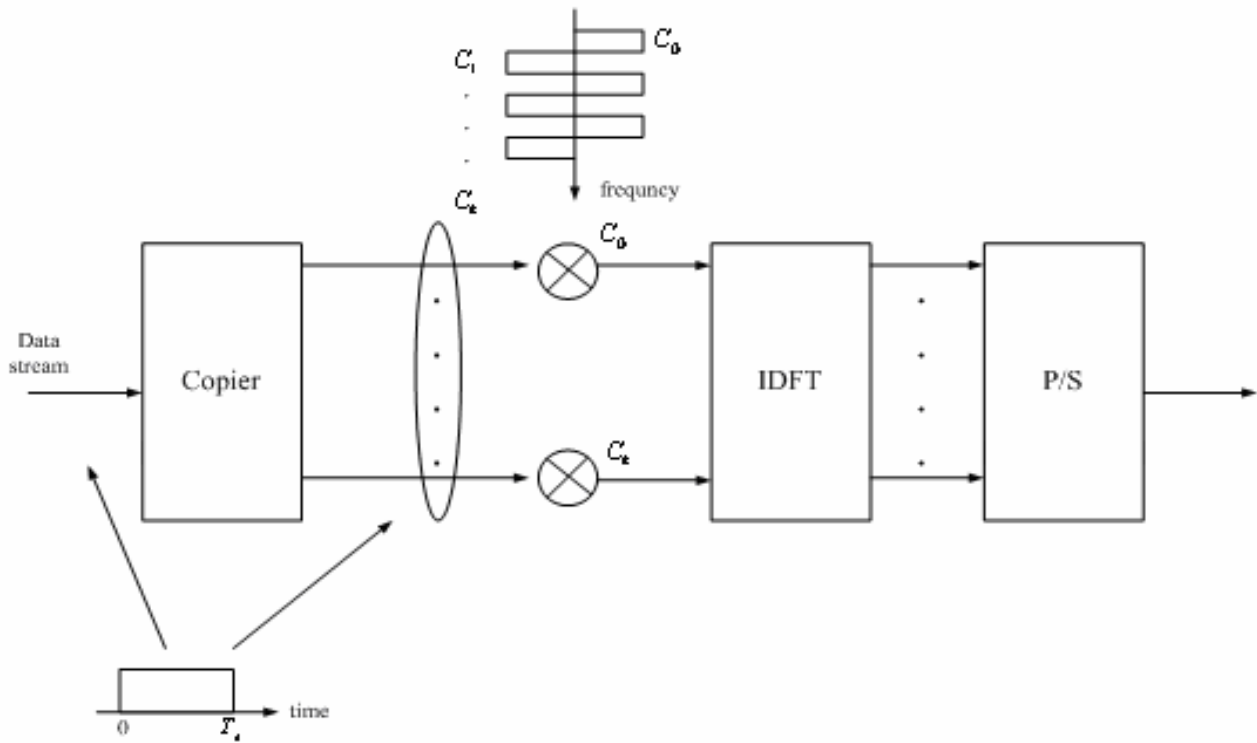

Figure 5: Transmitter of MC-CDMA

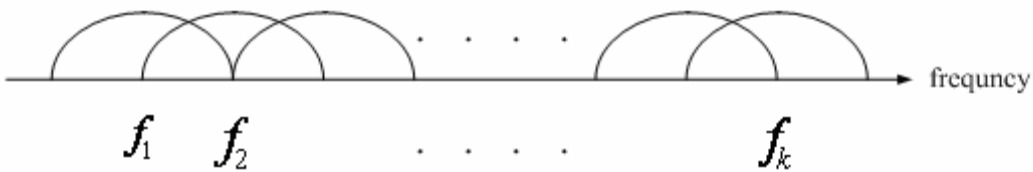

Figure 6: Power spectrum of transmitted signal

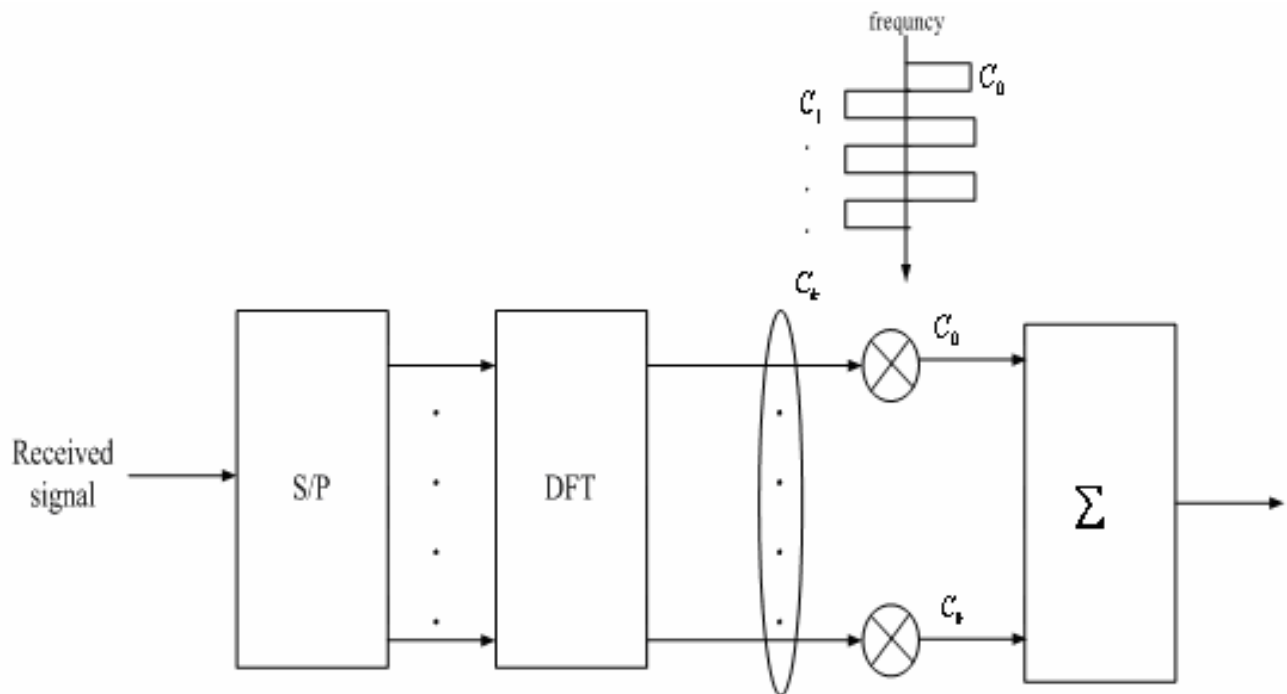

Figure 7: Receiver of MC-CDMA

2.1 Multi Carrier Code Divisions Multiple Accesses (MC-CDMA):

Multi Carrier Code Division Multiple Access (MC-CDMA) is a relatively new concept. Its development aimed at improved performance over multipath links. MC-CDMA is a modulation method that uses multi carrier transmission of DS-SS type signals. An MC-CDMA transmitter spreads the original data stream in the frequency domain over different sub carriers using a given spreading code. In this system the sub carriers convey the same information at one time. The MC-CDMA offers better frequency diversity to combat frequency selective fading.

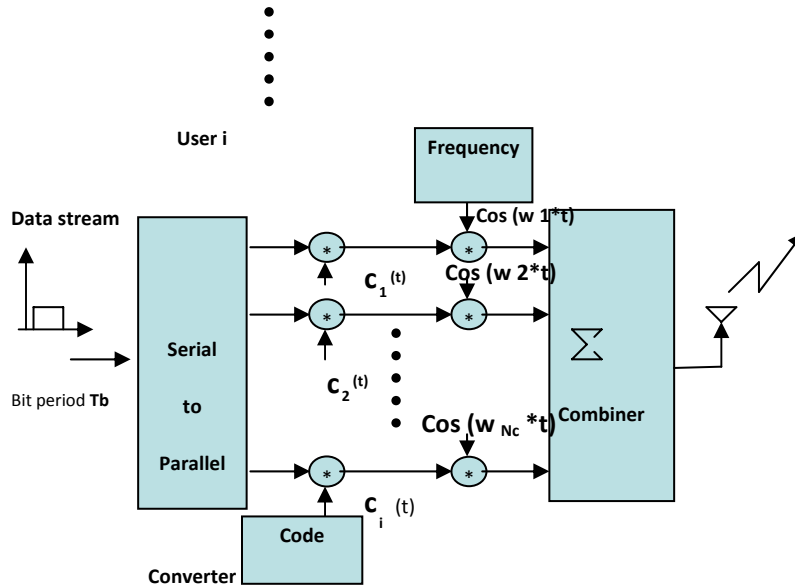

Figure 8: MC-CDMA transmitters

In figure 5 we see the transmitter MC-CDMA system for i number of user. The MC-CDMA transmitter spreads the original data stream using a given spreading code in the frequency domain. The code generator creates different unique codes for each different user and then combines together. Then the frequency generator combines different carrier frequency to the data signal and then combines the entire signal together by a combiner. After combining all the signals the CDMA antenna transmits the signals over the wireless media.

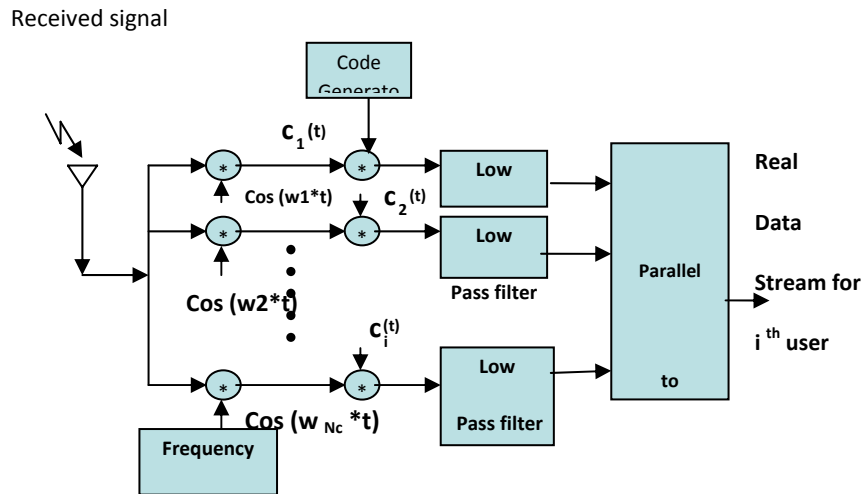

Figure 9: MC-CDMA receiver

In figure 6 the MC-CDMA receiver is designed by the capacity of i number of user. MC-CDMA receiver also receives the transmitted signal as a summation of i number of users. At first demodulates the received signal by the same carrier frequency of each signal and then the signals multiply with the specific codes given by the receiver code generator. Then we get the signal of i^{th} user which is same for transmitter and receiver. After that low pass filter remove the high frequencies portion of the signal. Finally, the P/S converter presents the actual digital data signal.

2.2 Direct Sequence Code Division Multiple Access (DS-CDMA):

Direct sequence code division multiple access (DS-CDMA) is an attractive allocation technique that allows users to be simultaneously active over the total available bandwidth. In Direct Sequence CDMA system transmission, the user data signal is multiplied by a pseudo random code sequence.

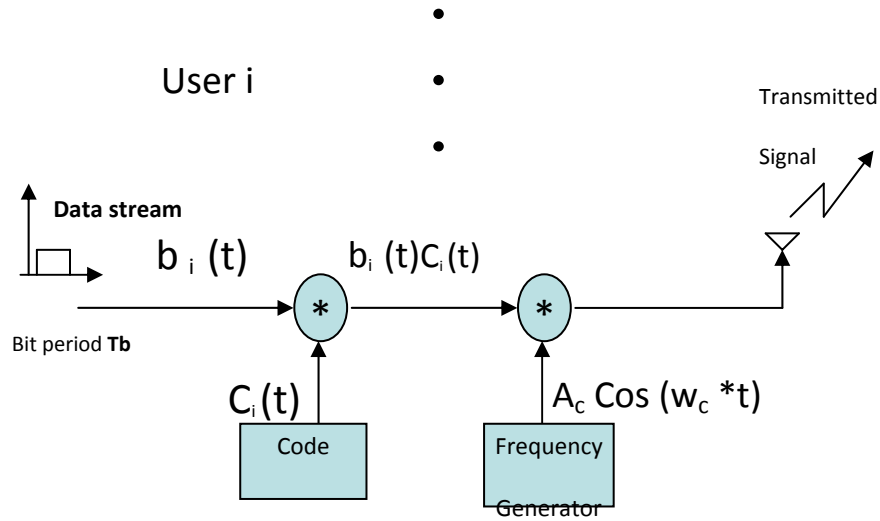

Figure 10: DS-CDMA transmitter

In figure 3 the DS-CDMA transmitter is design by the capacity of i number of user. The DS-CDMA transmitter combines the original data stream using a given spreading code in the time domain. Here, t is time, $b_i(t)$ is the data stream of i^{th} user $C_i(t)$ is the pseudo random code. $b_i(t)C_i(t)$ is i^{th} user data stream after combines the code width. The transmitter generates unique code for each user over one bit period; T_b by the Code Generator, The Frequency Generator generates one carrier frequency $\{A_c \cos(w_c * t)\}$ for each user for phase shift keying modulation technique. After combining and modulation of digital data, it is transmitted by the CDMA antenna over the wireless media like air.

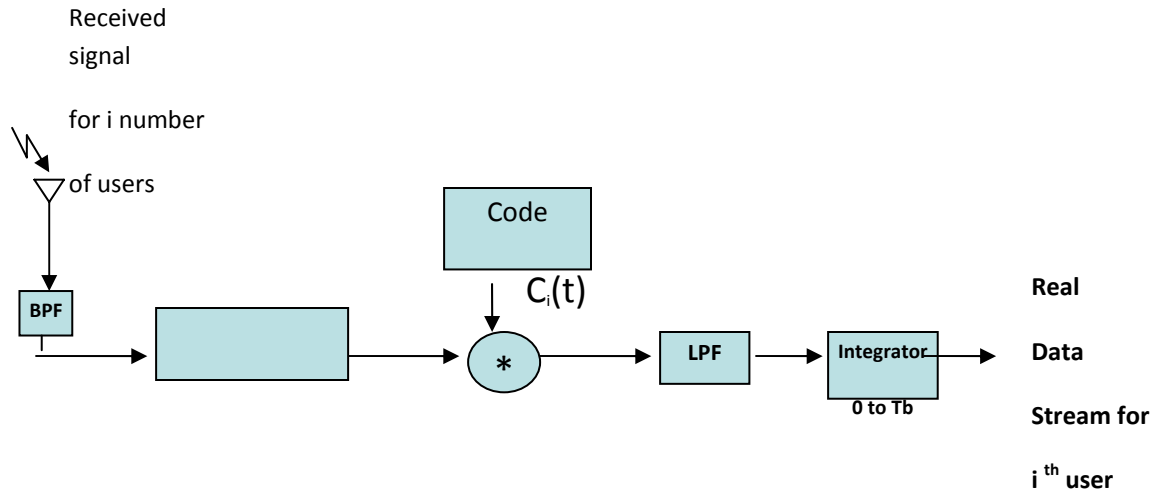

Figure 11: DS-CDMA receiver

In figure 4 the DS-CDMA receiver is designed by the capacity of i number of user. Then it will face the MAI for user 1 to user $(i-1)$. At First the CDMA antenna received the transmitted signal and then it passes through a band pass filter (BPF). BPF remove any unwanted signal. Demodulator demodulates the signal with $\{A_c \text{ Cos } (w_c *t)\}$. Then the received signal is again multiplied by the same code $C_i(t)$. After this the code has been removed, so we get the original transmitted user data. The low pass filter rejects the high frequency portion of data signals. At last, the integrator provides the real i^{th} user digital data. Integrator reduces the multi-access interference (MAI).

2.3 Multi Carrier Direct Sequence Code Division Multiple Access (MC DS CDMA):

The multicarrier DS-CDMA transmitter spreads the S/P converter data streams using a given spreading code in the time domain so that the resulting spectrum of each sub carrier can satisfy the orthogonality condition with the minimum frequency separation. This scheme is orthogonally proposed for a uplink communication channel, because the introduction of OFDM signaling into DS-CDMA scheme is effective for the establishment of a quasi-synchronous channel.

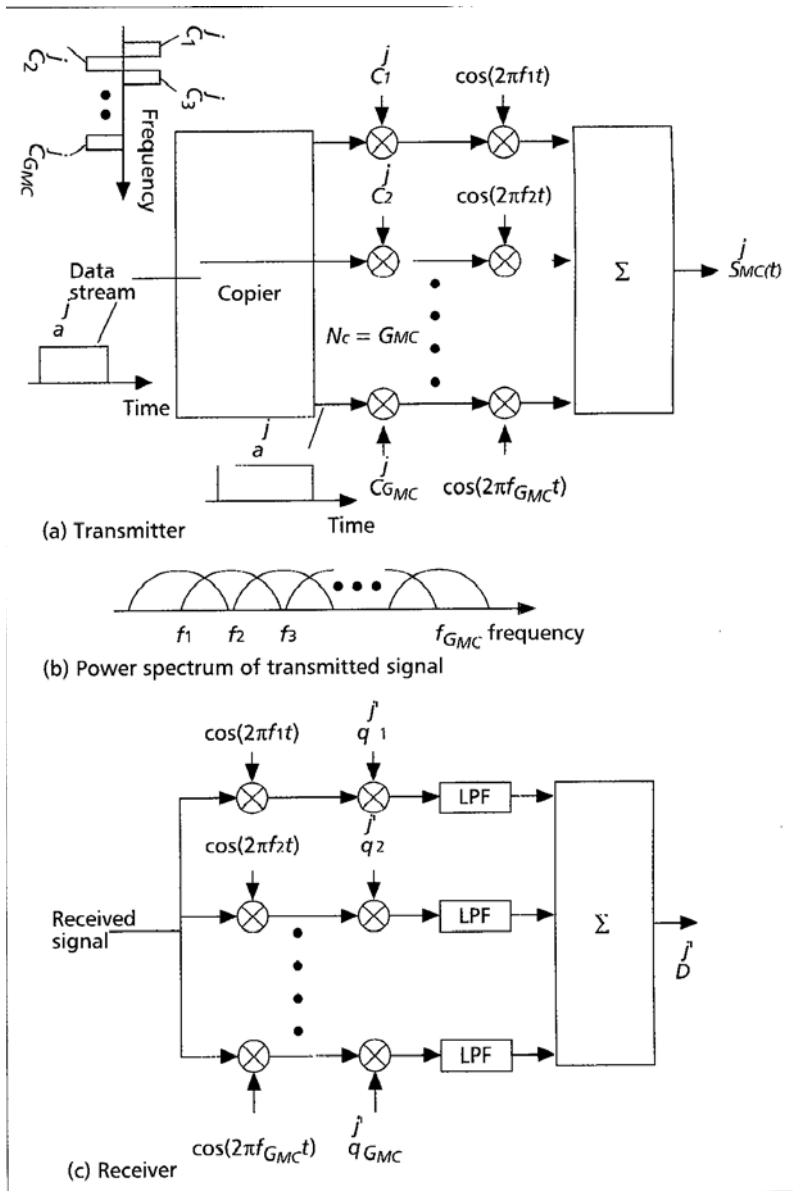

Figure 12: MC DS-CDMA scheme: a) transmitter; b) power spectrum of us transmitted signal; c) receiver.

In the figure show the MC DS-CDMA transmitted signal, respectively, where G_{md} denotes the processing gain, N the number of sub carriers, and $C_j(t)$. The spreading code of the j -th user.

In a MC DS-CDMA scheme with a larger sub carrier separation is proposed in order to yield both frequency diversity improvement and narrow band interference suppression. In addition, a MC DS-CDMA scheme, which transmits the game data using several sub carriers, is proposed in.

2.4 Comparison of the Spreading codes in all CDMA techniques:

DS-CDMA:

(1) The spreading code is used on time domain and all subcarrier remain relationship of orthogonal.

MC-CDMA:

(1) The spreading code is used on frequency domain.

(2) The spreading code is used on frequency domain, so receiver always can use scatter of signal power in different subcarrier to get frequency diversity.

(3) It used in downlink.

MC DS-CDMA:

(1) The spreading code is used on time domain and all subcarrier remain relationship of orthogonal.

(2) It used in uplink.

(3) It is compatible with IS-95 DS-CDMA at present.

CHAPTER 3

Analysis of MC DS CDMA

3.1 Expression of Multi Access Interference (MAI):

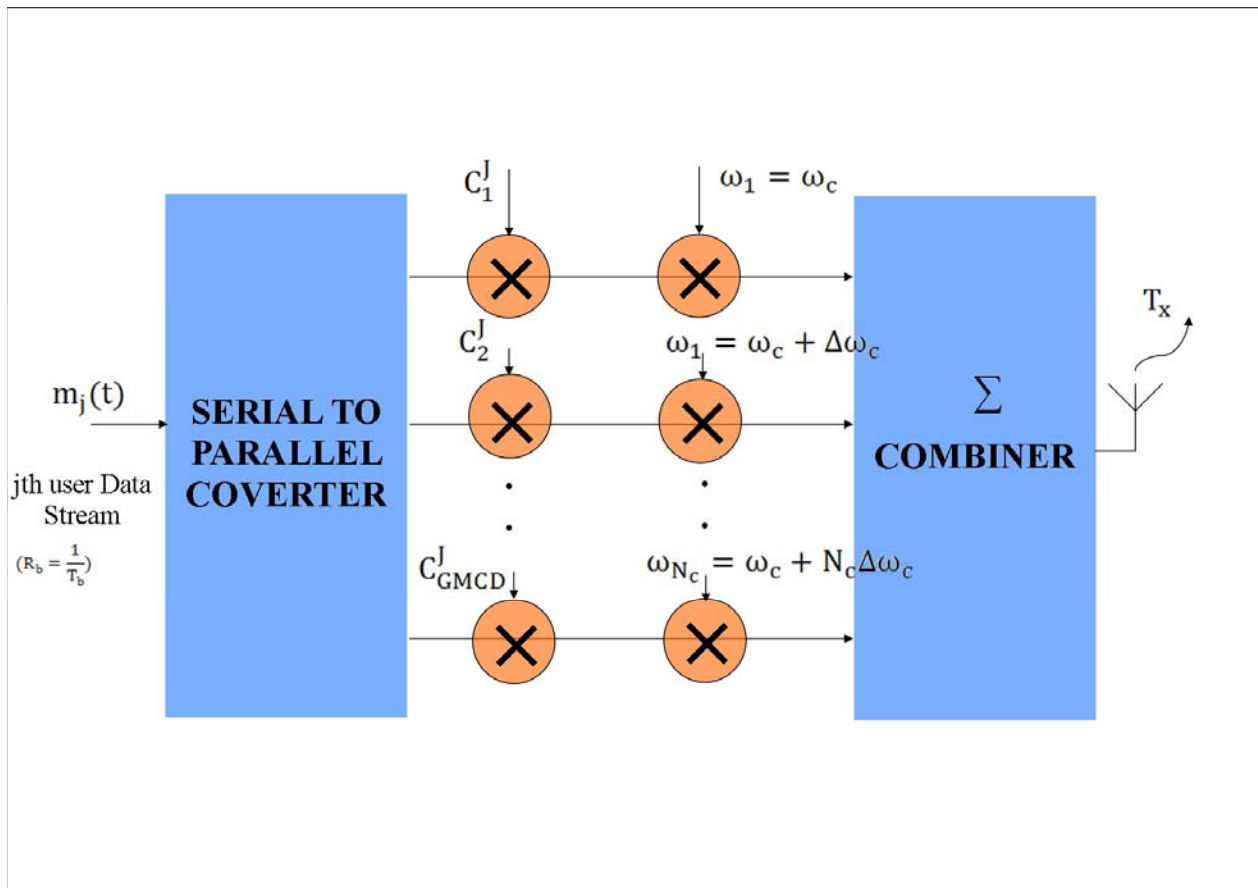

Figure 13: MC DS CDMA system

j = no. of user

p = Chip power

N_c = no. of sub-carrier

$N =$ No. of PN code allocated per subcarrier

$L =$ Code length of each user $= N_c * N$

$c^j =$ code of j -th user

$R_b =$ Bitrate of the user

$m_j(t) =$ input data stream of the j -th user

$b_n^j =$ n -th bit of $m_j(t)$

$K =$ Boltzman constant

$T =$ Room temperature

$B =$ Bandwidth

Thus,

$$m_j(t) = \sum_{n=-\infty}^{\infty} b_n^j ; \text{ where, } b_n = \pm 1$$

Now the input data of j -th user are converted into N_c number of parallel data stream and each of parallel data is coded by the respective section of chips of the j -th user; code c^j . Thus, each data is spreaded in time domain and spreaded data then is modulated by the respective sub-carrier.

Now to write the general expression of the sub-carrier, let us consider the following,

$w_c =$ Frequency spacing between two successive channel

$\Delta w_c =$ Frequency spacing between two successive channel

The general expression of the sub-carrier is

$$\sum_{k=1}^{N_c} \sqrt{2P} \cos(w_c t + k\Delta w_c t + \varphi_k) ; \text{ Where, } \varphi_k = \text{instantaneous phase of the } k\text{th subscriber}$$

Thus, the expression of the transmitted signal of the j -th user is,

$$S_T(t) = \sum_{k=1}^{N_c} \left[\sqrt{2P} b_{n,k}^j \left(\sum_{n=0}^{N-1} c_{n,k}^j \right) \cos(w_c t + k\Delta w_c t + \varphi_k) \right] ;$$

Where, $b_{n,k}^j = n - \text{th bit of } j - \text{th user, which is being modulated by the } k - \text{th channel,}$

$C_{x,k}^j = x - \text{th chip of teh } k - \text{th channel of } j - \text{th user code}$

The signal, while propagating, suffers frequency selective multipath Rayleigh fading,

$$r(t) = \sum_{m=1}^j [\alpha \sqrt{2p} \sum_{k=1}^{N_c} \{b_{n,k}^m (\sum_{x=0}^{N-1} C_{x,k}^m)\} \cos(\omega_c t + k\Delta\omega_c t + \varphi_k + \theta)]$$

Let, $\alpha =$ Amplitude distortion due fading,

$\beta =$ Phase distortion due fading,

Now, while reception, the receiver receives signal transmitted by all the j-th of user. Thu, the expression of the received signal is,

$$r(t) = \sum_{m=1}^j [\alpha \sqrt{2p} \sum_{k=1}^{N_c} \{b_{n,k}^m (\sum_{x=0}^{N-1} C_{x,k}^m)\} \cos(\omega_c t + k\Delta\omega_c t + \delta\omega_c t + \varphi_k + \theta)]$$

But due to Doppler Effect, there will be effect in carrier frequency if $\delta\omega_c$ be the arbitrary amount of frequency offset, then, the received signal becomes,

$$r(t) = \sum_{m=1}^j [\alpha \sqrt{2p} \sum_{k=1}^{N_c} \{b_{n,k}^m (\sum_{x=0}^{N-1} C_{x,k}^m)\} \cos(\omega_c t + k\Delta\omega_c t + \delta\omega_c t + \varphi_k + \theta)] + N_0$$

Where $N_0 = \text{AWGN}$

Now, this signal is de-modulated and then it takes the form,

$$r(t) = \sum_{m=1}^j [\alpha \sqrt{2p} \sum_{k=1}^{N_c} \{b_{n,k}^m (\sum_{x=0}^{N-1} C_{x,k}^m)\} \cos\{(\omega_c + \delta\omega_c + k\Delta\omega_c)t + \varphi_k + \theta\}] \cdot [\sqrt{2p} \cos(\omega_c + k\Delta\omega_c)] + N_0$$

Then,

$$r(t) = \alpha 2p \sum_{m=1}^j \sum_{k=1}^{N_c} \{b_{n,k}^m (\sum_{x=0}^{N-1} C_{x,k}^m)\} \cos\{(\omega_c + \delta\omega_c + k\Delta\omega_c)t + \varphi_k + \theta\} \cdot \cos(\omega_c + k\Delta\omega_c)t + N_0$$

Now, after decoding by using the j-th users code, we get,

$$r(t) = \alpha 2p \sum_{m=1}^J \sum_{k=1}^{N_c} [b_{n,k}^m \left(\sum_{x=0}^{N-1} C_{x,k}^m \right) \cos\{(\omega_c + \delta\omega_c + k\Delta\omega_c)t + \varphi_k + \theta\} \cdot \cos(\omega_c + k\Delta\omega_c)t] \\ * \left(\sum_{x=0}^{N-1} C_{x,k}^j \right) + N_0$$

Separating the j-th users terms, we get,

$$r(t) = \alpha 2p \sum_{k=1}^{N_c} [b_{n,k}^j \left(\sum_{x=0}^{N-1} C_{x,k}^j \right) \left(\sum_{x=0}^{N-1} C_{x,k}^j \right) \cos\{(\omega_c + k\Delta\omega_c)t + \delta\omega_c t + \varphi_k + \theta\} \cdot \cos(\omega_c + k\Delta\omega_c)t] \\ + \alpha 2p \sum_{m=1}^{j-1} \sum_{k=1}^{N_c} [b_{n,k}^m \left(\sum_{x=0}^{N-1} C_{x,k}^m \right) \left(\sum_{x=0}^{N-1} C_{x,k}^j \right) \cos\{(\omega_c + k\Delta\omega_c)t + \delta\omega_c t + \varphi_k \\ + \theta\} \cdot \cos(\omega_c + k\Delta\omega_c)t] + N_0$$

Let,

$$(\omega_c + k\Delta\omega_c)t = A$$

&

$$\delta\omega_c t + \varphi_k + \theta = B$$

Then,

$$r(t) = \alpha 2p \sum_{k=1}^{N_c} [b_{n,k}^j \cos(A+B) \cos A] + \alpha 2p \sum_{m=1}^{j-1} \sum_{k=1}^{N_c} [b_{n,k}^m \left(\sum_{x=0}^{N-1} C_{x,k}^m \right) \left(\sum_{x=0}^{N-1} C_{x,k}^j \right) \cos(A+B) \cos A] + N_0 ;$$

$$[\text{Applying Auto-correlation, } \sum_{x=0}^{N-1} C_{x,k}^j \cdot C_{x,k}^j = 1]$$

$$r(t) = \alpha 2p \sum_{k=1}^{N_c} \left[\frac{1}{2} b_{n,k}^j [\cos(A+B+A) + \cos(A+B-A)] \right] \\ + \alpha 2p \sum_{m=1}^{j-1} \sum_{k=1}^{N_c} \left[\frac{1}{2} b_{n,k}^m \left(\sum_{x=0}^{N-1} C_{x,k}^m \right) \left(\sum_{x=0}^{N-1} C_{x,k}^j \right) [\cos(A+B+A) + \cos(A+B-A)] \right] + N_0$$

After passing through LPF, we got,

$$r(t) = \alpha p \sum_{k=1}^{N_c} \frac{1}{2} b_{n,k}^j \cos(\delta w_c t + \varphi_k + \theta) + \alpha p \sum_{m=1}^{j-1} \sum_{k=1}^{N_c} [b_{n,k}^m \left(\sum_{x=0}^{N-1} C_{x,k}^m \right) \left(\sum_{x=0}^{N-1} C_{x,k}^j \right) \cos(\delta w_c t + \varphi_k + \theta) + N_0$$

$$\text{Desired signal} = \alpha p \sum_{k=1}^{N_c} \frac{1}{2} b_{n,k}^j \cos(\delta w_c t + \varphi_k + \theta)$$

$$\text{MAI} = \alpha p \sum_{m=1}^{j-1} \sum_{k=1}^{N_c} [b_{n,k}^m \left(\sum_{x=0}^{N-1} C_{x,k}^m \right) \left(\sum_{x=0}^{N-1} C_{x,k}^j \right) \cos(\delta w_c t + \varphi_k + \theta)]$$

$$\text{AWGN} = N_0 = KTB$$

So, the

$$\text{Signal power} = \frac{1}{2} \alpha^2 p^2 \left(\sum_{k=1}^{N_c} b_{n,k}^j \right)^2$$

$$\text{Noise power} = \frac{1}{2} \alpha^2 p^2 \left[\sum_{m=1}^{j-1} \sum_{k=1}^{N_c} b_{n,k}^m \left(\sum_{x=0}^{N-1} C_{x,k}^m C_{x,k}^j \right) \right]^2 + KTB$$

[here, P=Ps]

$$ICI = \frac{1}{2} \alpha^2 P_s^2 \left[\sum_{m=1}^{j-1} \sum_{k=1}^{N_c} b_{n,k}^m \left(\sum_{x=0}^{N-1} C_{x,k}^m C_{x,k}^j \right) \right]^2$$

To find Signal to interference ratio,

$$SIR = \frac{\frac{1}{2} \alpha^2 P_s^2 \left(\sum_{k=1}^{N_c} b_{n,k}^j \right)^2}{\frac{1}{2} \alpha^2 P_s^2 \left[\sum_{m=1}^{j-1} \sum_{k=1}^{N_c} b_{n,k}^m \left(\sum_{x=0}^{N-1} C_{x,k}^m C_{x,k}^j \right) \right]^2 + KTB}$$

[Here if we consider, $b_{n,k}^j = 1$ then $(\sum_{k=1}^{N_c} b_{n,k}^j) = N_c$ and if $c_{x,k}^m \cdot c_{x,k}^j = 1$ then $(\sum_{x=0}^{N-1} c_{x,k}^m \cdot c_{x,k}^j) = 1$

$$= \frac{\frac{1}{2} \alpha^2 P_f^2 N_c^2}{\frac{1}{2} \alpha^2 P_f^2 [\sum_{m=1}^{j-1} \sum_{k=1}^{N_c} b_{n,k}^m]^2 + KTB}$$

[Let, $b_{n,k}^m = 1$]

$$= \frac{\frac{1}{2} \alpha^2 P_f^2 N_c^2}{\frac{1}{2} \alpha^2 P_f^2 [\sum_{m=1}^{j-1} N_c]^2 + KTB}$$

[Let, $N_c = 1$]

$$SIR = \frac{\frac{1}{2} \alpha^2 P_f^2 N_c^2}{\frac{1}{2} \alpha^2 P_f^2 (j-1)^2 + KTB}$$

Conditional BER,

$$ber(\alpha) = 0.5 \operatorname{erfc}\left(\sqrt{\frac{SIR(\alpha)}{2}}\right)$$

Un-conditional BER,

$$BER(\Delta f) = \int_0^{\infty} ber(\alpha) p(\alpha) d\alpha$$

$$BER(\Delta f) = \sum_{i=1}^N ber(\alpha_i) p(\alpha_i)$$

Here,

$$p(\alpha) = \left[\frac{\alpha}{\alpha^2} e^{-\frac{\alpha^2}{2\alpha^2}} \right]$$

CHAPTER 4

Results & Discussion

4.1 Plots fo simple SIR vs. j:

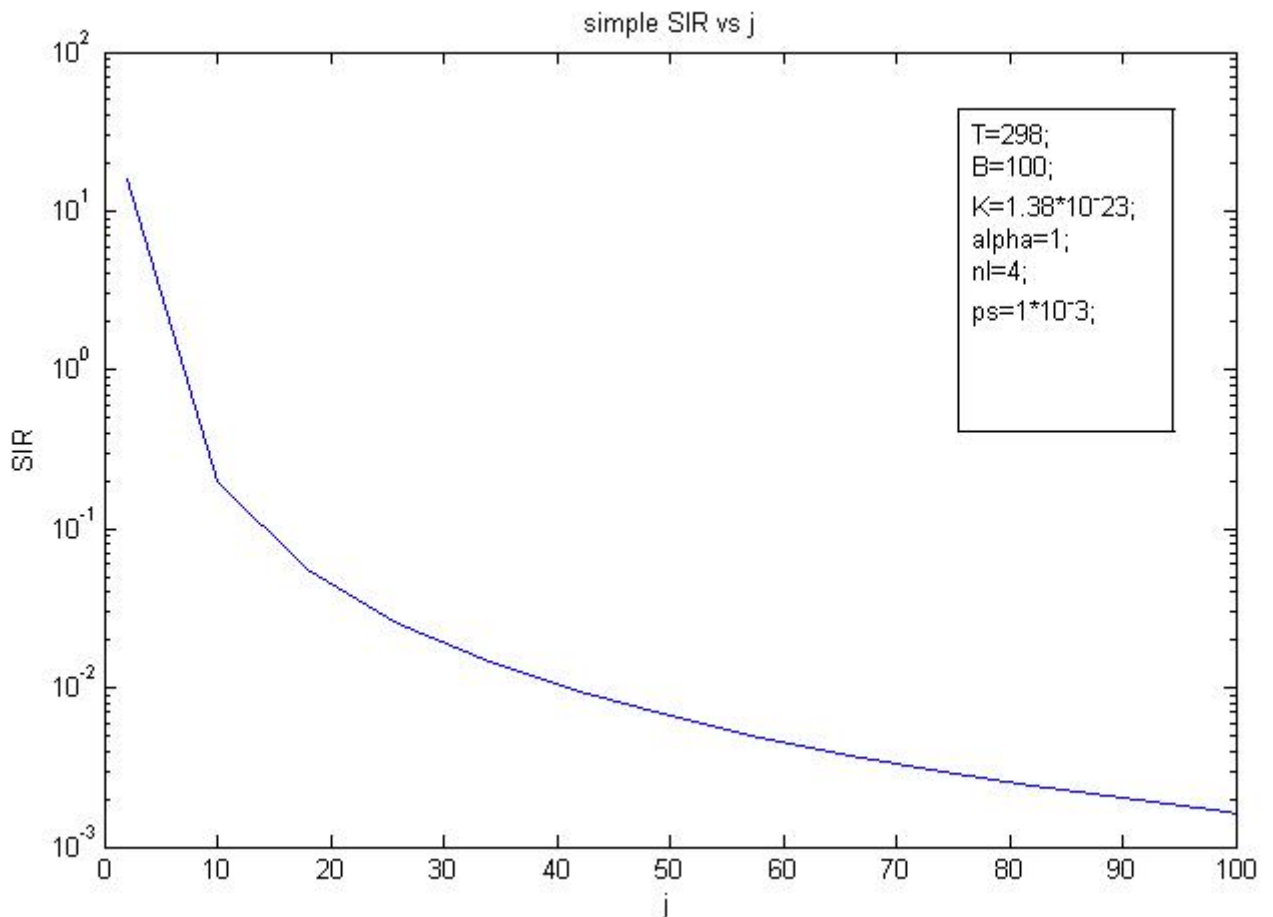

Figure 14: simple SIR vs. j

Here we can see the plot between the numbers of user (j) vs. the signal to interference ratio (SIR). If we increase the numbers of user (j), the signal to interference ratio will decrease. The signal to interference ratio depends on signal power (P_s). Here $P_s=1\text{mw}$ and the curve is for the number of sub-carrier (N_c) = 4.

4.2 Plots of SIR vs. j (with value of N_c):

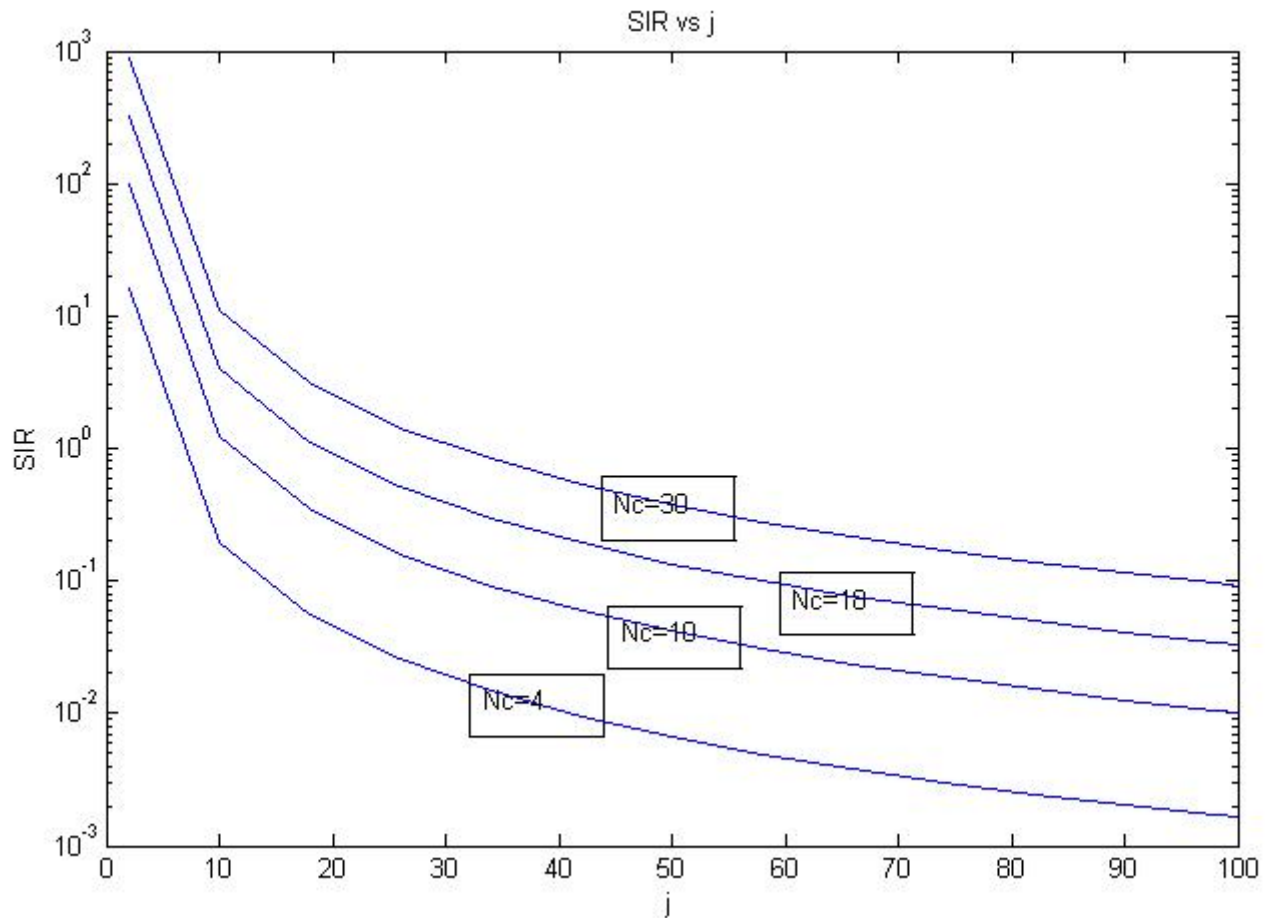

Figure 15: SIR vs. j (with value of N_c)

This figure is modified version of previous one. Here we can see that the plot is in between the number of user vs. signal to interference ratio. Here the signal power is 1mw and we vary the number of sub-carrier (N_c) such as $N_c = 4, 10, 18, 30$. If we increase the number of user (j) then the signal to interference ratio will be decrease.

4.3 Plots of SIR vs. j (cut from 10db):

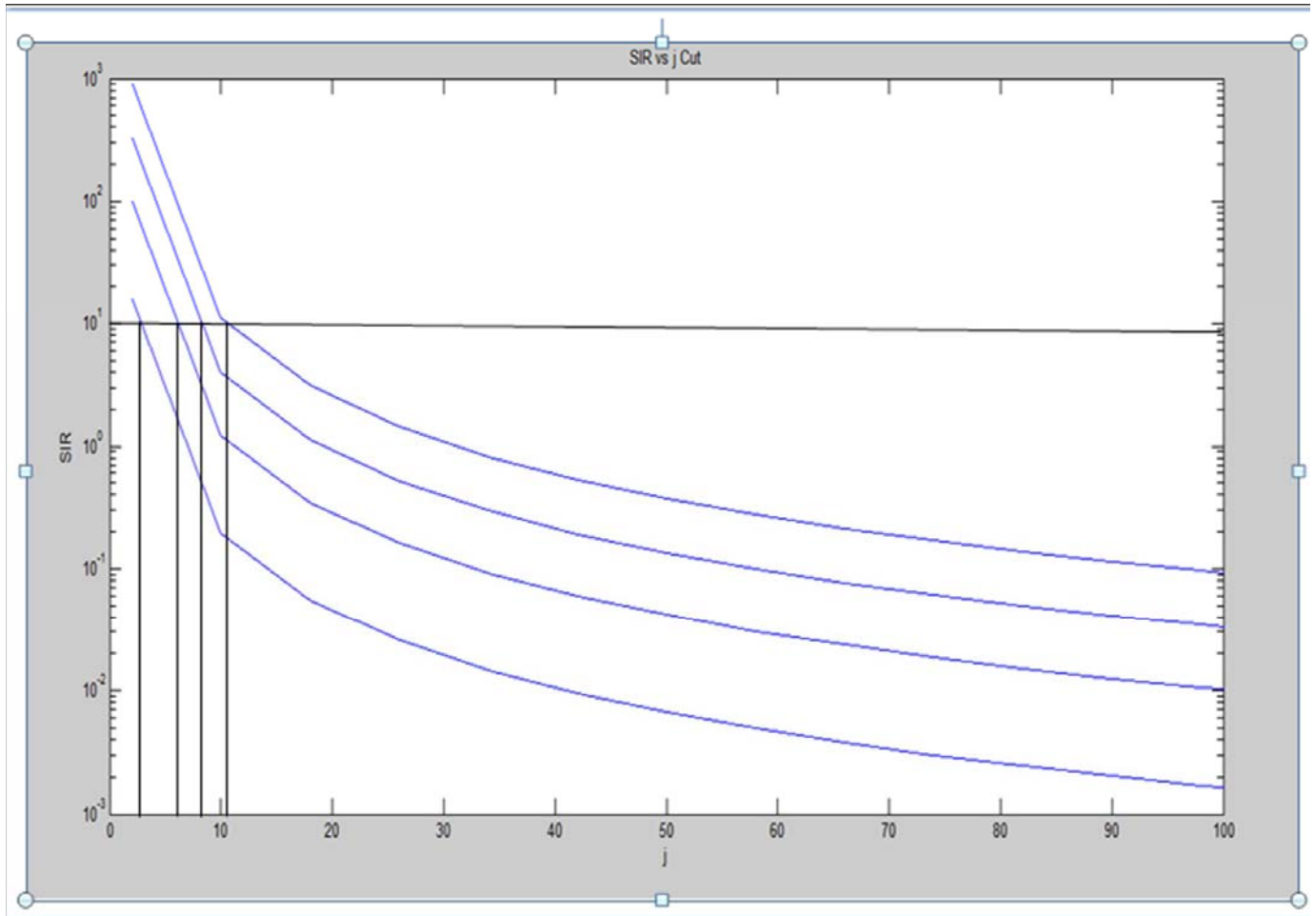

Figure 16: SIR vs. j (cut from 10db)

Here we can see that the plot is between the signals to interference ratio (SIR) vs. number of user (j). If we draw a axis with parallel to j from a particular SIR = 10db then we see that the axis intersects the N_c at 4, 10, 18 and 30. For $N_c = 4$ we got $j = 3$, for $N_c = 10$ we got $j = 6$, for $N_c = 18$ we got $j = 8$ and for $N_c = 30$ we got $j = 11$.

4.4 Plots of N_c vs j :

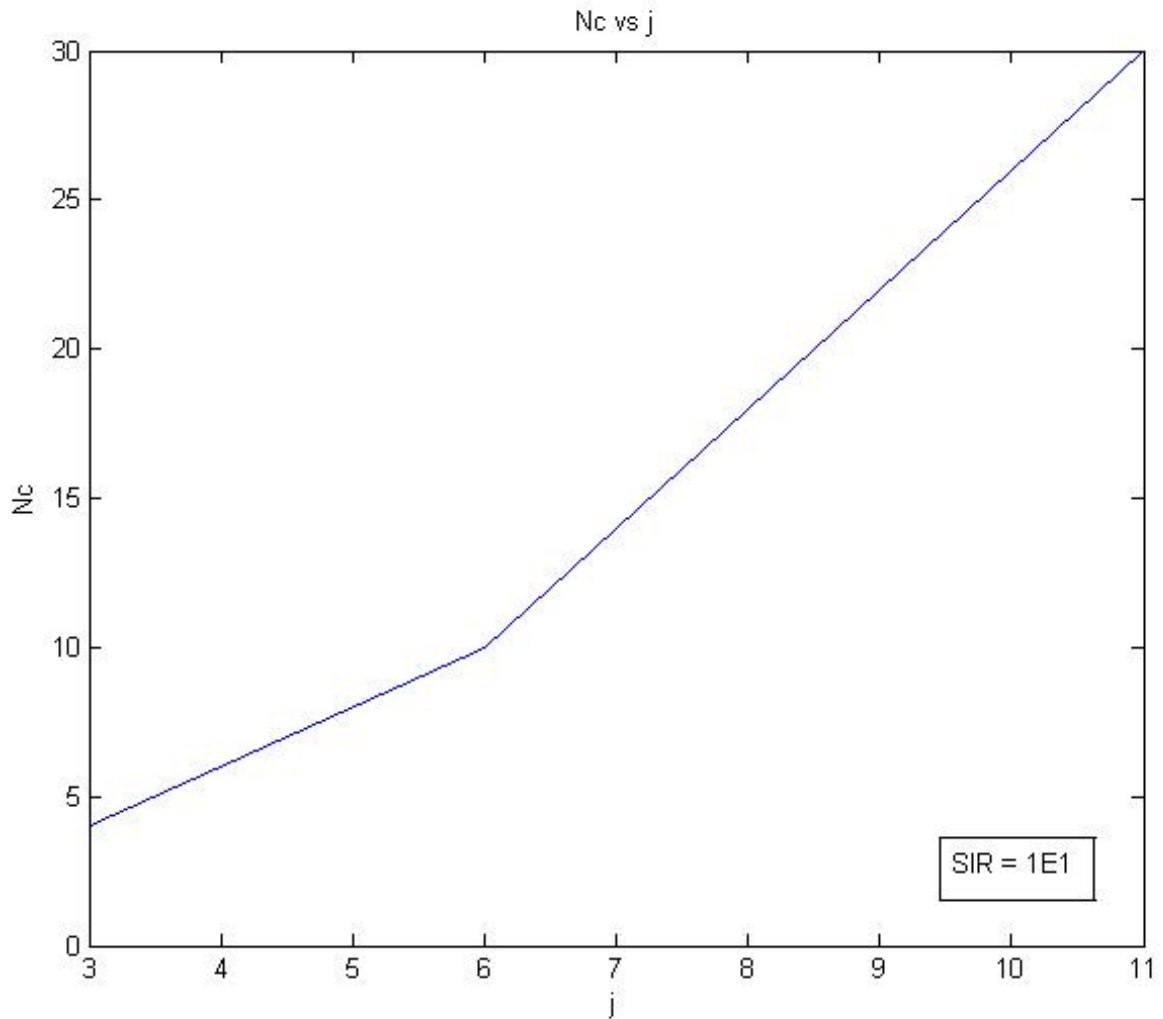

Figure 17: N_c vs j

Here we can see that the plot is between N_c vs. j . from the previous plot we found this plot. Here if we increase the j then N_c will be increase.

4.5 Plots of simple SIRdb vs. Ps:

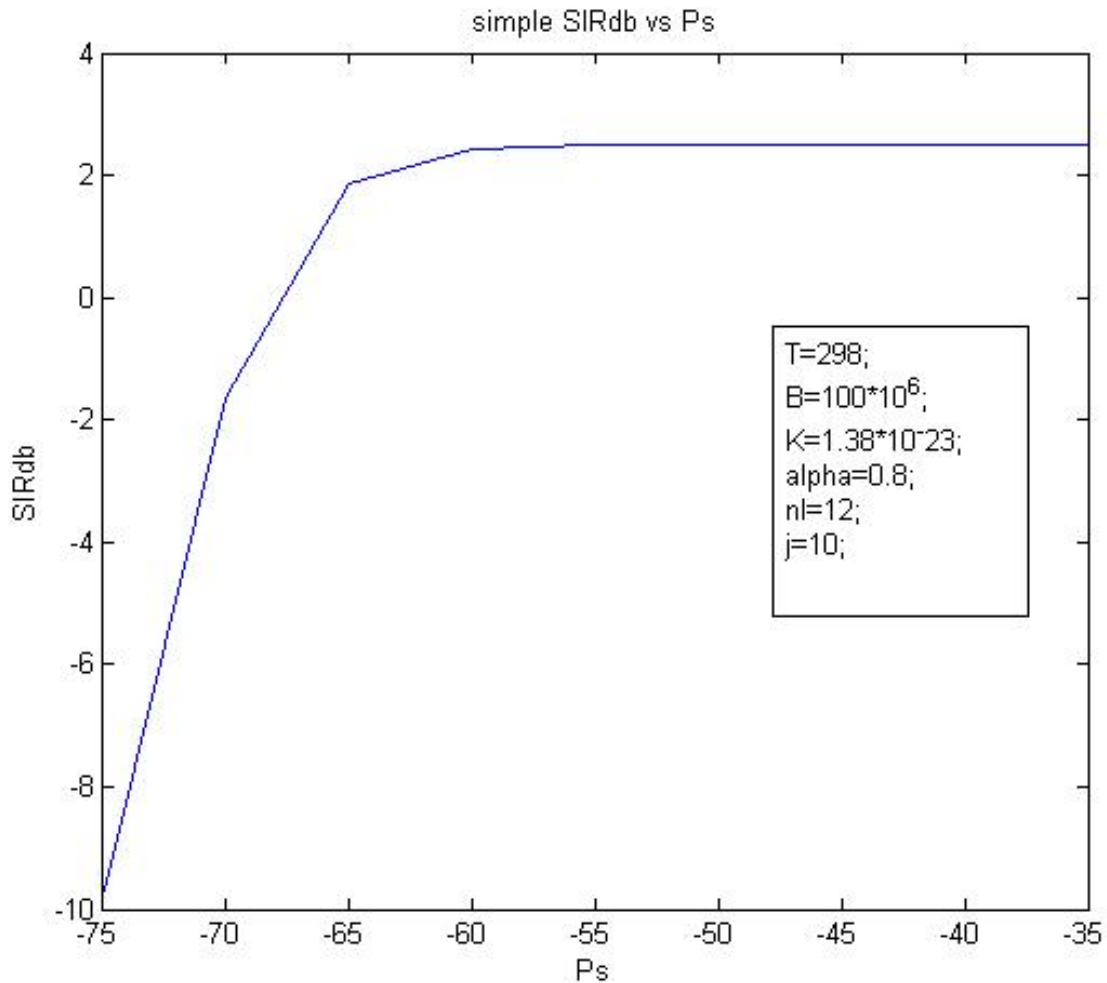

Figure 18: simple SIRdb vs. P_s

Here we can see that the plot is in between the signal power (P_s) vs. signal to interference ratio (SIR). If we increase the signal power (P_s) then signal to interference ratio (SIRdb) will increase. We found the curve for $\alpha = 0.8$ and consider 10 number of user.

4.6 Plots of SIRdb vs. Ps (with value j):

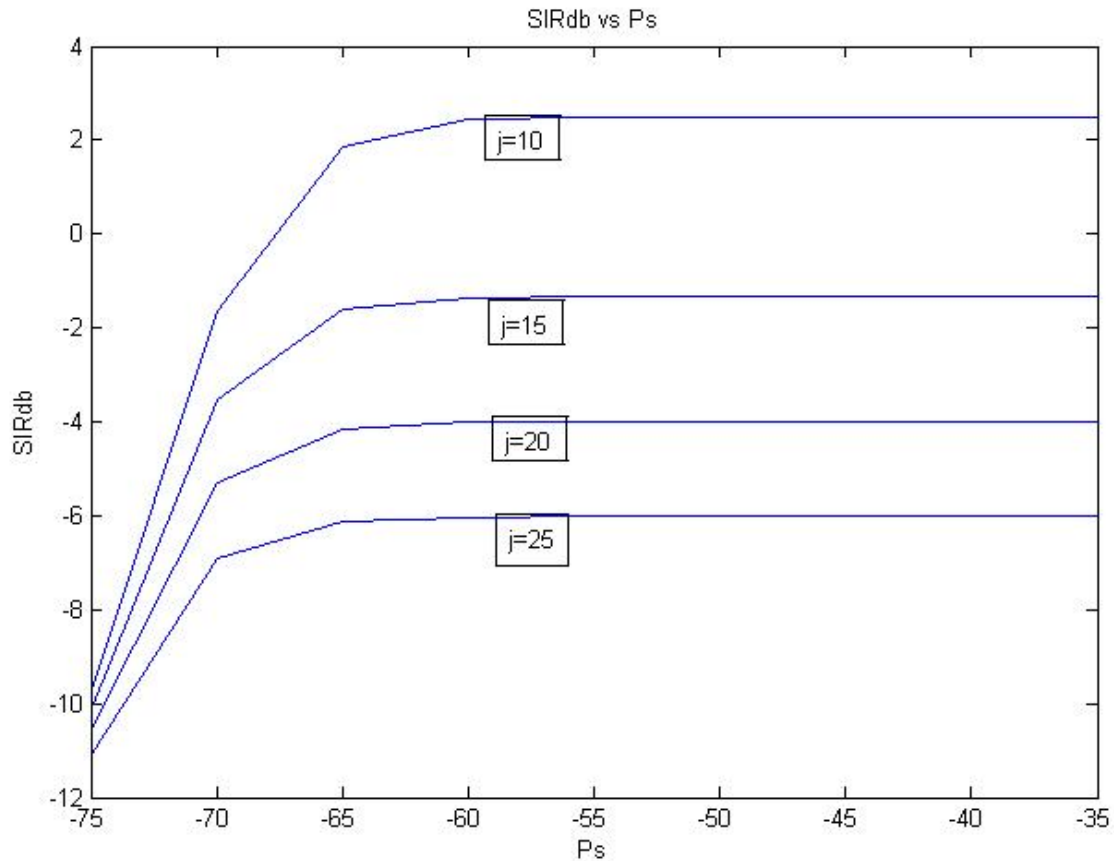

Figure 19: SIRdb vs. P_s (with value j)

Here we can see that the plot between signal power (P_s) vs. signal to interference ratio in db (SIRdb). If we increase the signal power (P_s) then SIRdb will be increase. Here alpha is fixed at 0.8. For different sets of number of user (j) we have got different curves. $j = 10, 20, 30, 40$.

4.7 Plots of SIRdb vs. Ps (cut from -7):

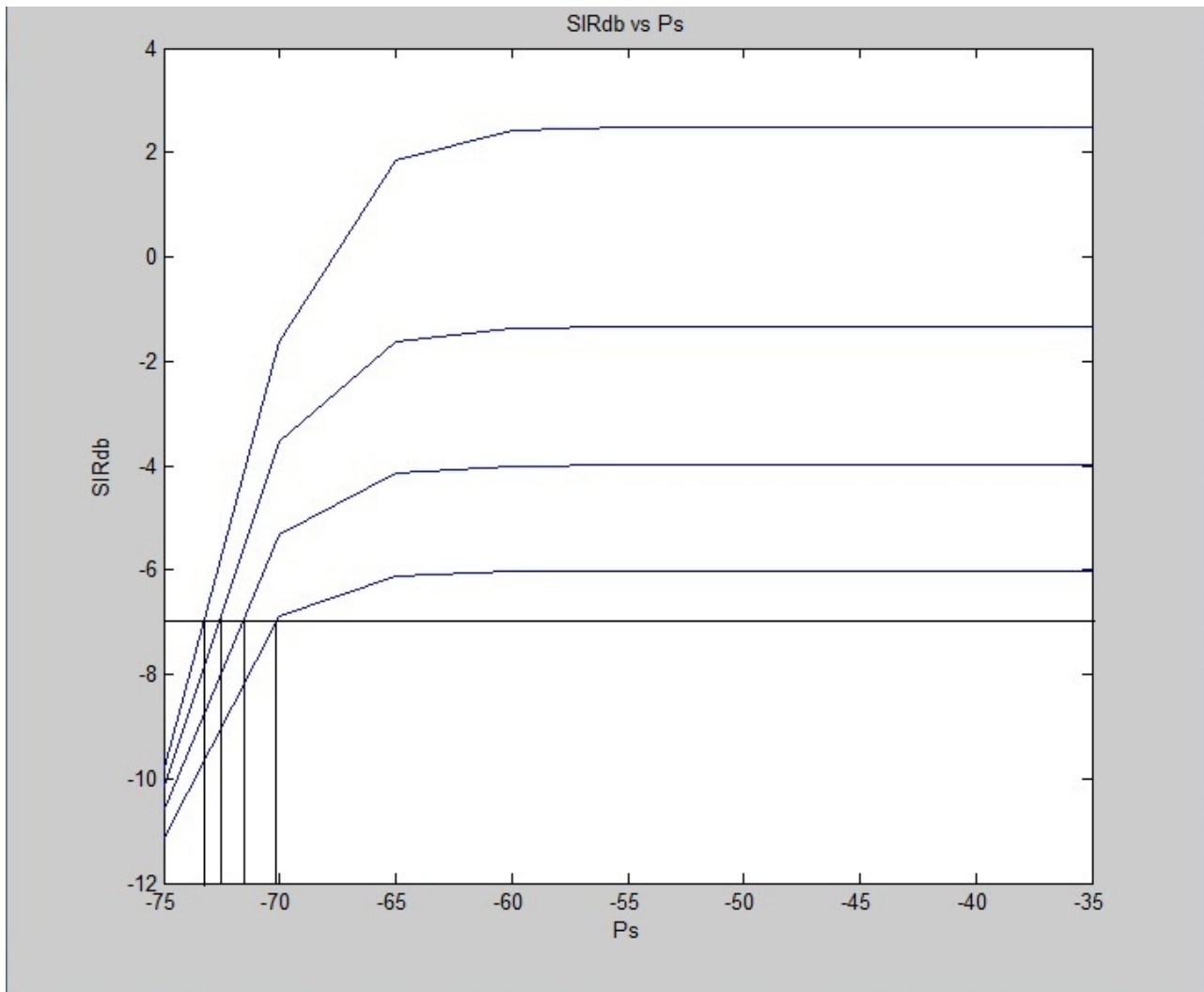

Figure 20: SIRdb vs. Ps (cut from -7)

Here we can see the plot between signal to interference ratio in db (SIRdb) vs. signal power (Ps). If we draw an axis parallel to Ps, we see that the axis intersects j at 10, 15, 20, and 25. Here for $j = 10$ we got $P_s = -73.2$, for $j = 15$ we got -72.6 , for $j = 20$ we got $P_s = -71.5$, and for $j = 25$ we got $P_s = -70.1$.

4.8 Plots of P_s vs. j (SIRdb = -7):

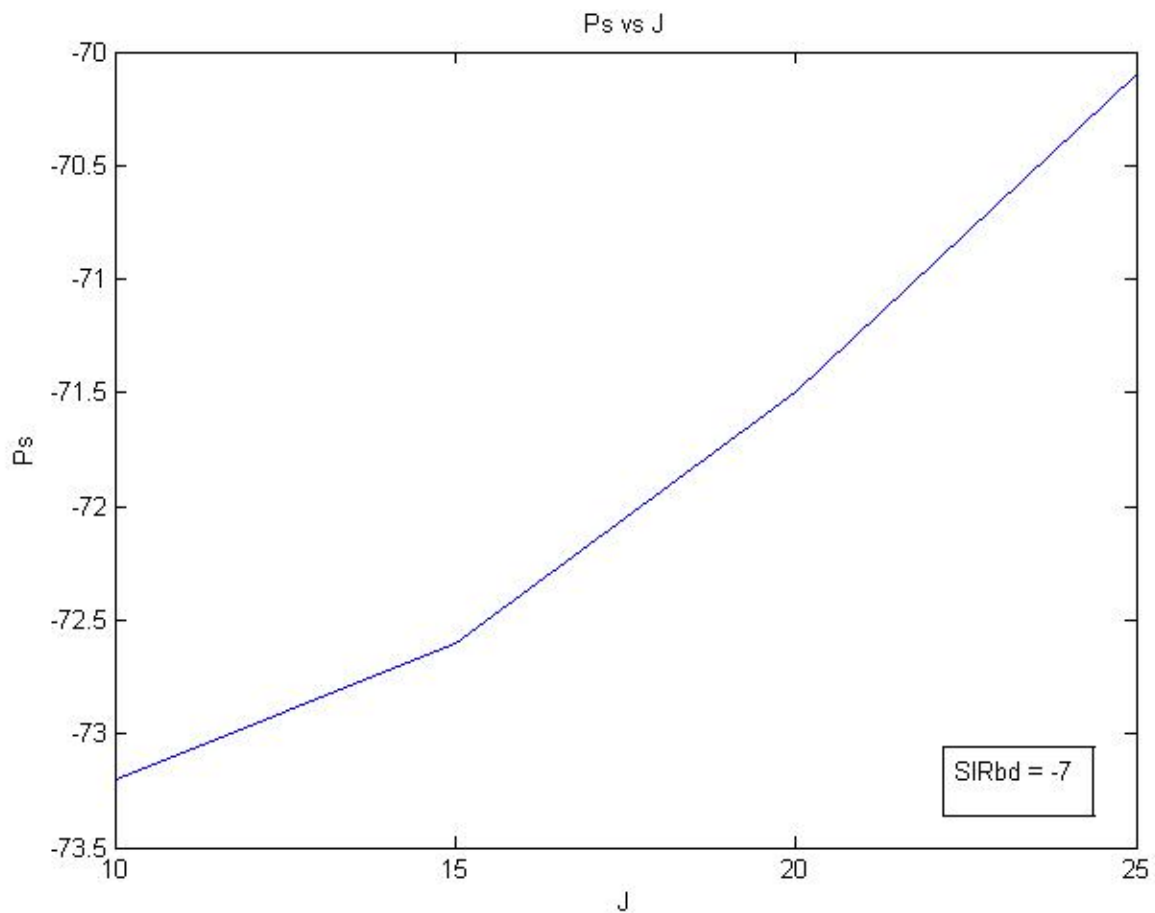

Figure 21: P_s vs. j (SIRdb = -7)

Here we can see the plot is between the signal power (P_s) vs. the number of user (j). if we increase the number of user (j) then the signal power (P_s) will increase. Here the SIRdb = -7.

4.9 Plots of ICI vs. j:

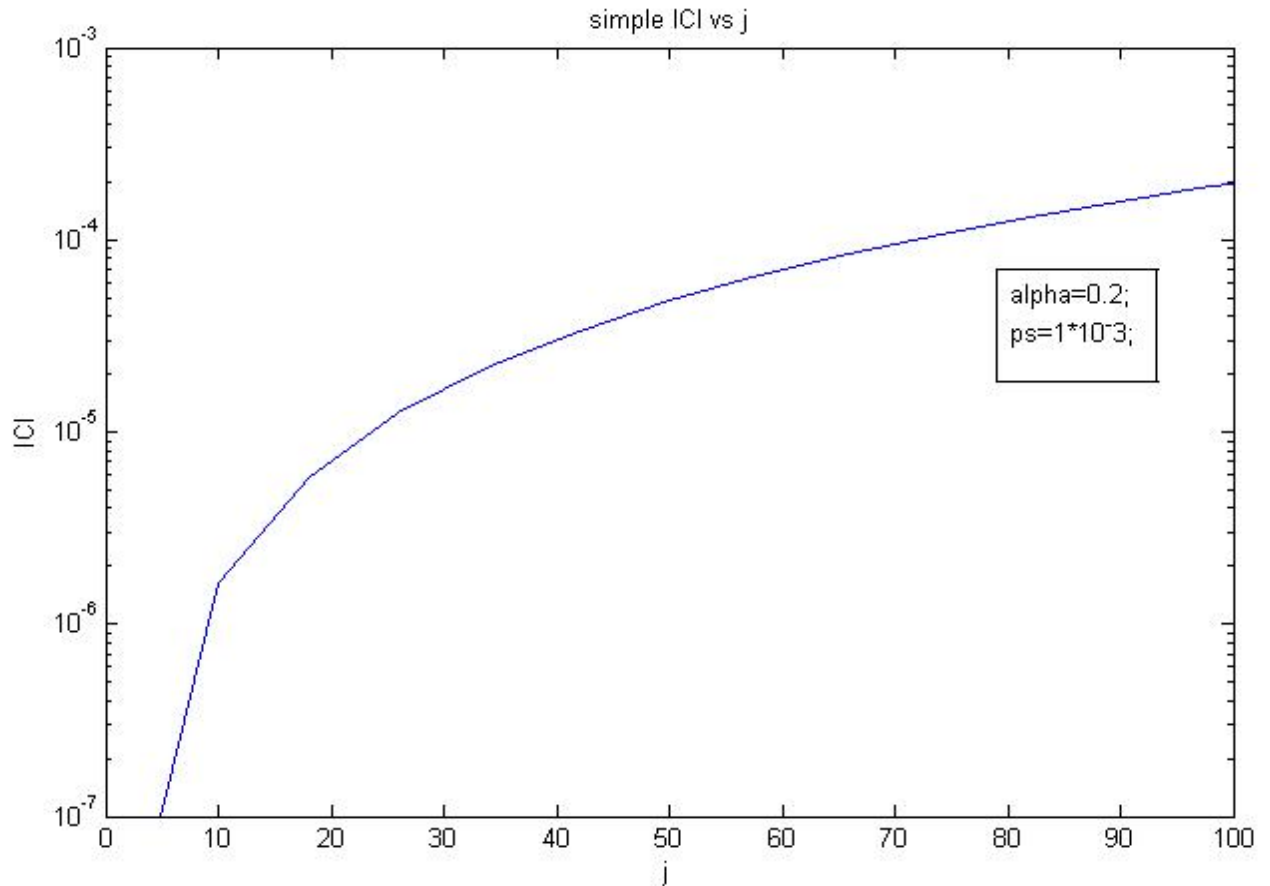

Figure 22: ICI vs. j

Here we can see that the plot is about the number of user (j) vs. Inter Carrier Interference (ICI). If we increase the number of user (j) then the inter carrier interference (ICI) will be increase. Here the number of user is 14 times, signal power is 1mw and the we have used the ICI equation and the curve is for the value of $\alpha = 0.2$

4.10 Plots of ICI vs. j (with value alpha):

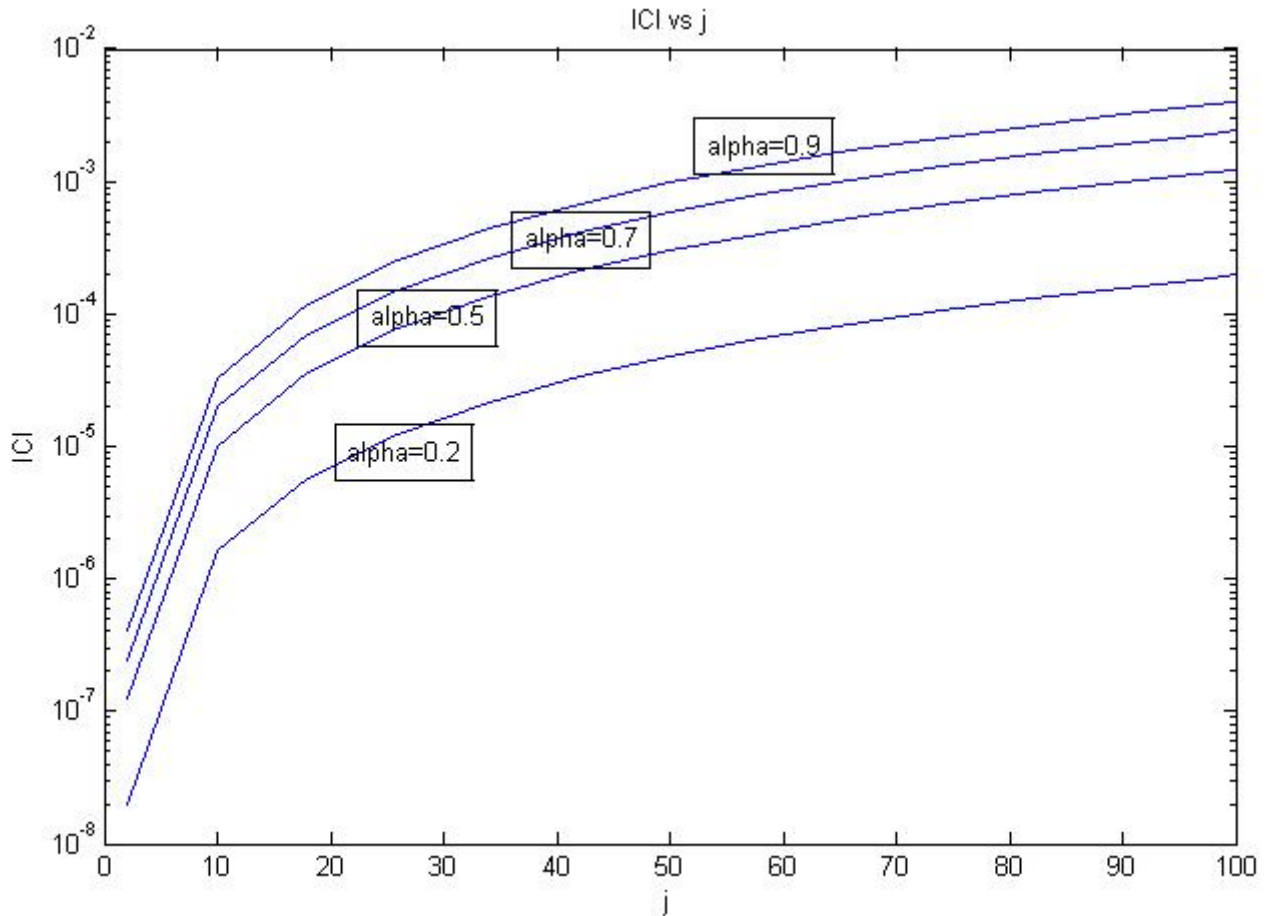

Figure 23: ICI vs. j (with value alpha)

Here we can see the modified version of the plot between the numbers of user (j) vs. inter-carrier interference (ICI). We have plotted these curves for different values of alpha such as alpha = 0.2, 0.5, 0.7, 0.9. The signal power is also $P_s = 1\text{mw}$ and the number of user is 14.

4.11 Plots of ICI vs. j (cut from ICI = 10^5):

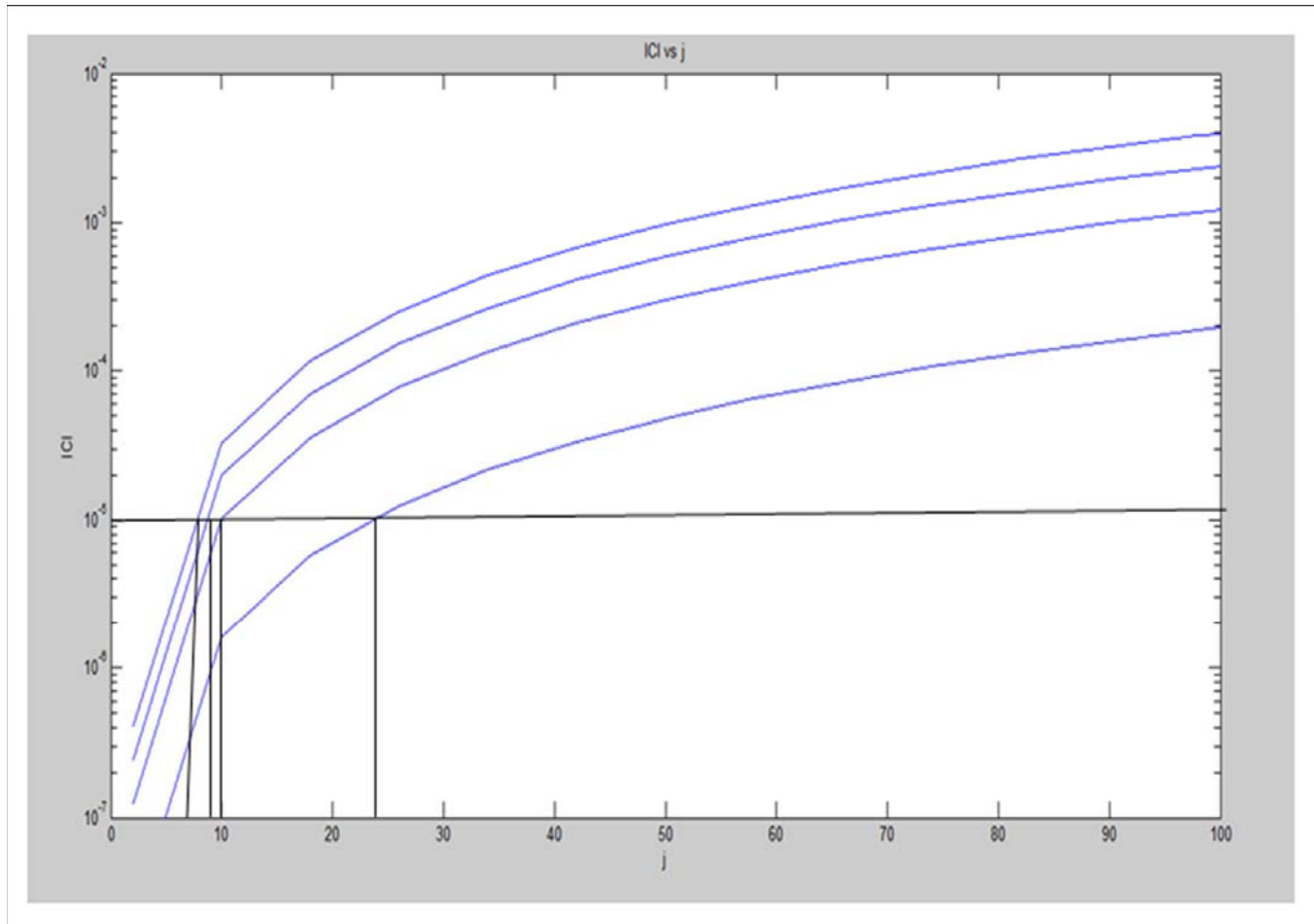

Figure 24: ICI vs. j (cut from ICI = 10^5)

This is from previous figure. If we draw an axis with parallel to j from a particular ICI = 10^5 , we see that the axis intersect the alpha at 0.9, 0.7, 0.5, and 0.2. For alpha = 0.9 we got j = 7, for alpha 0.7 we got j = 9, for alpha = 0.5 we got j = 10, for alpha = 0.2 we got j = 24.

4.12 Plots of alpha vs. j:

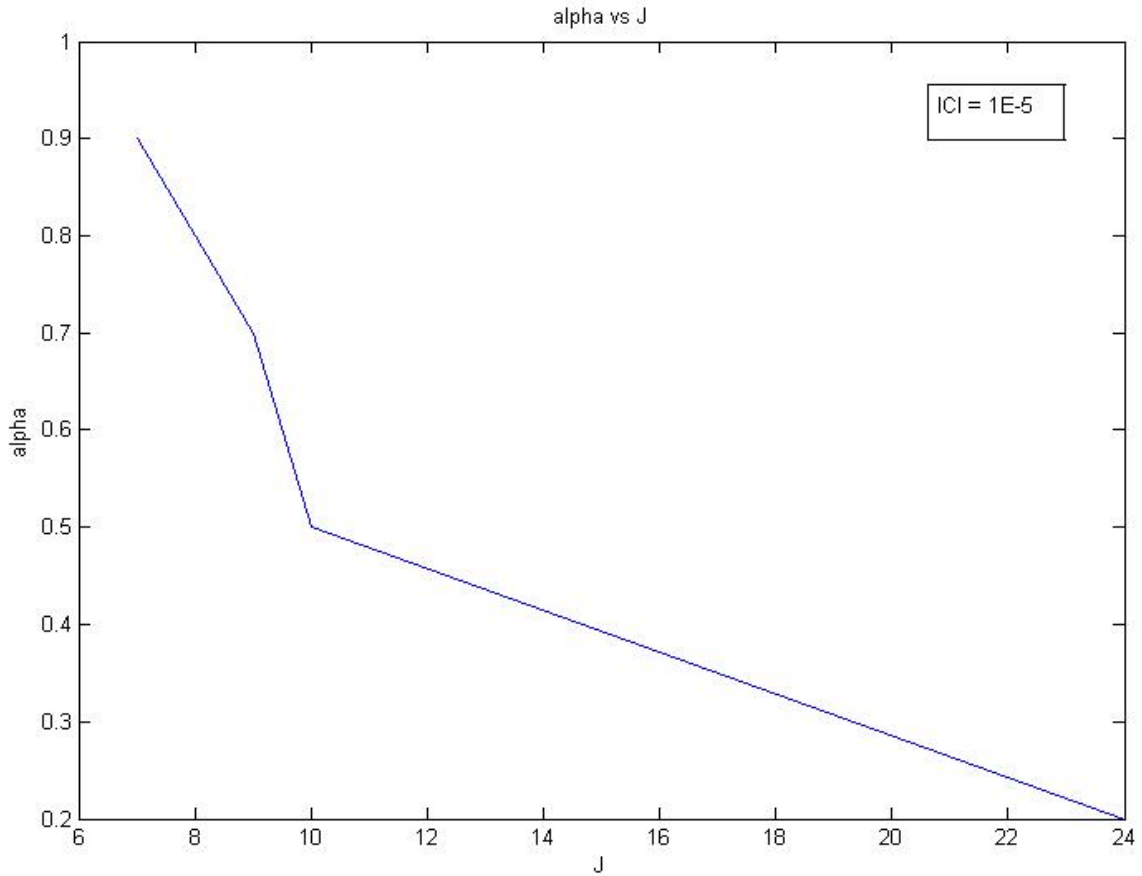

Figure 25: alpha vs. j

Here we can see that the plot of number of user (j) vs. amplitude distortion due to fading (alpha). If we increase the number of user then amplitude distortion due to fading (alpha) will be decrease. Here, we consider Inter carrier interference (ICI) as 10^{-5} .

4.13 Plots of berdb vs. Ps:

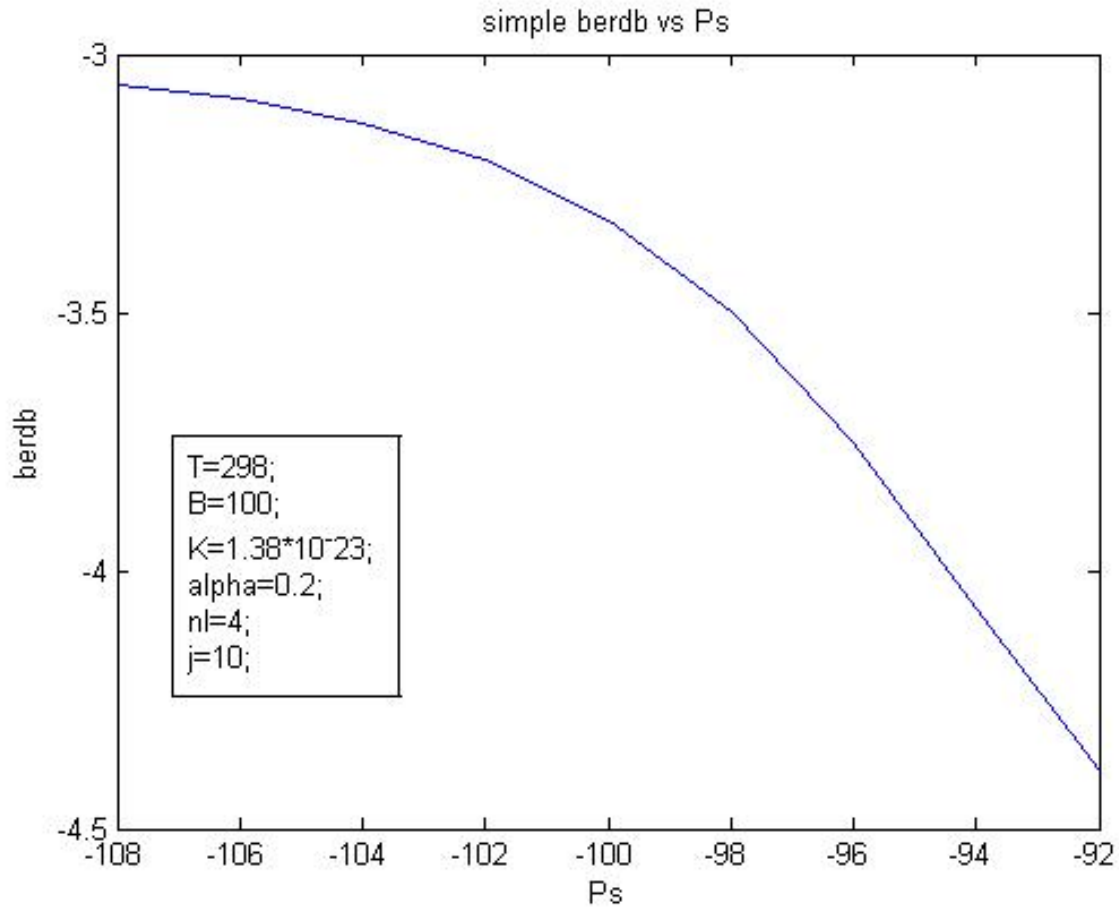

Figure 26: berdb vs. Ps

Here we can see that the plot is in between the signal power (Ps) vs. bit error rate in db form. If we increase the signal power (Ps) then bit error rate (berdb) will be decrease. Here for alpha = 0.2 we got the curve for 10 user and four sub-carrier.

4.14 Plots of berdb vs. Ps (with value of alpha):

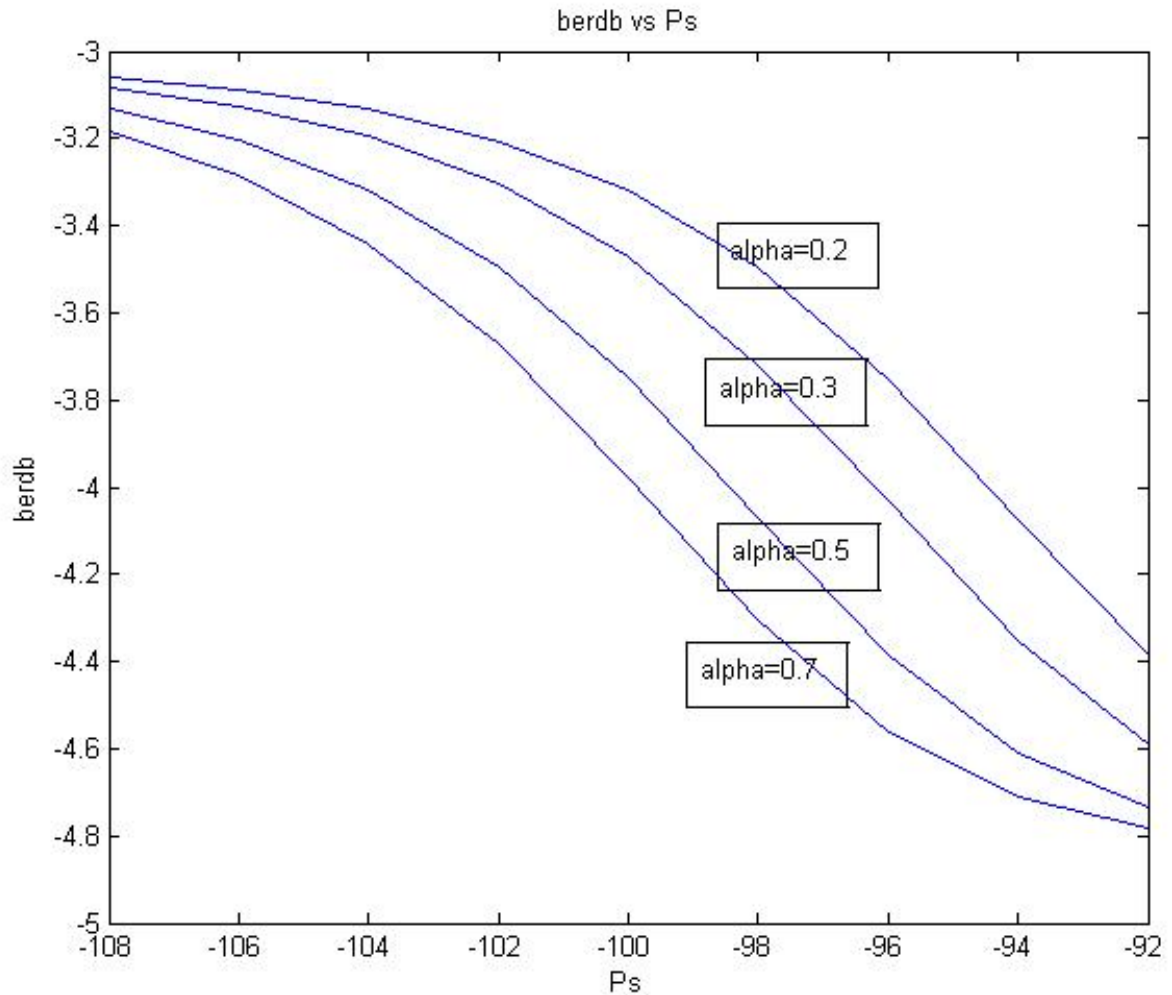

Figure 27: berdb vs. Ps (with value of alpha)

Here, we can see that the plot of signal power (Ps) vs. the conditional bit error rate (ber). In this plot, if we increase the signal power (Ps) then bit error rate will be decreasing. Here the entire curves are for different values of alpha such as alpha = 0.2, 0.3, 0.5, 0.7.

4.15 Plots of berdb vs. Ps (cut berdb from -4):

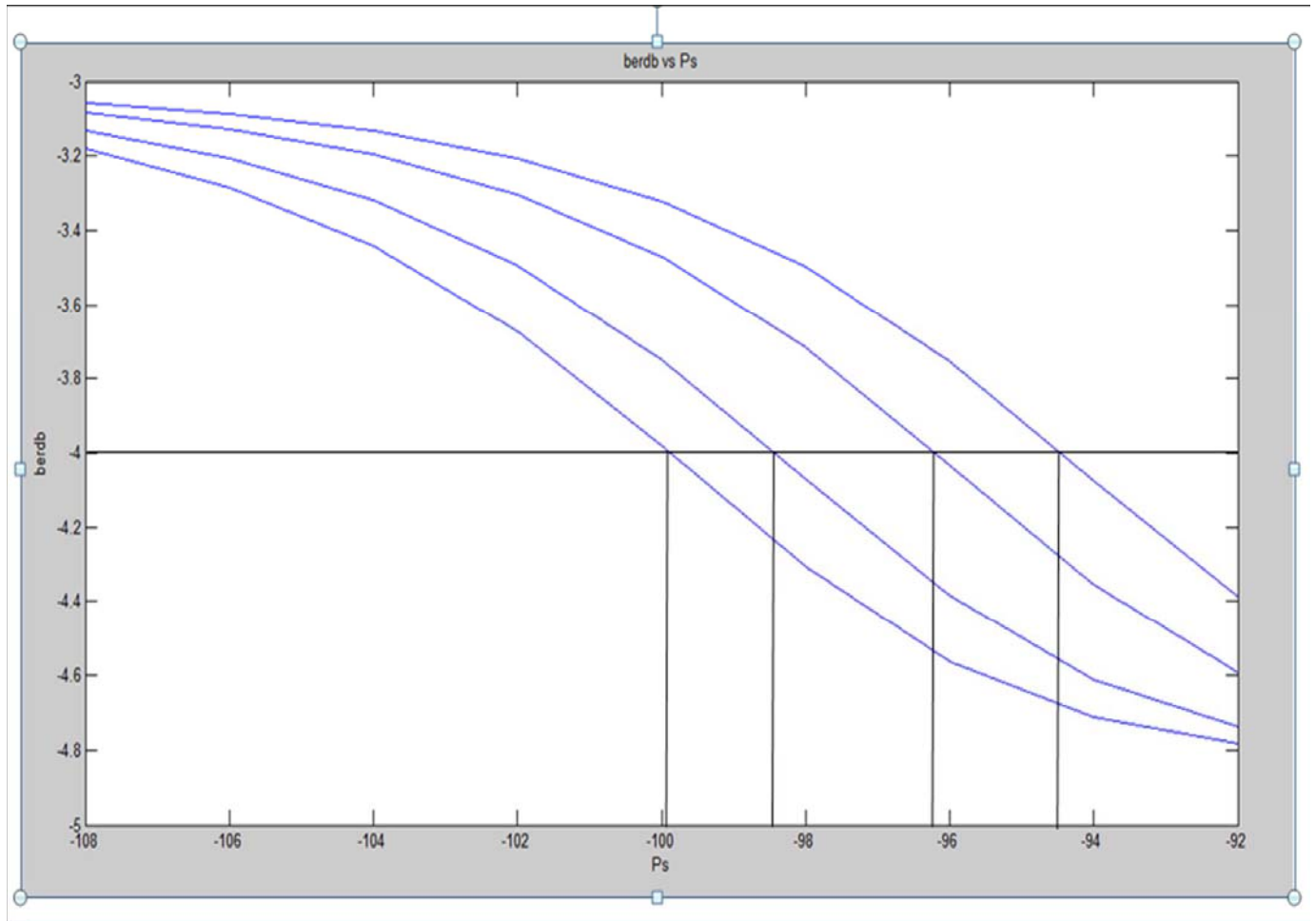

Figure 28: berdb vs. Ps (cut berdb from -4)

This figure is from previous graph. If we draw an axis with parallel to Ps from a particular berdb = -4 we see that the axis intersect alpha at 0.2, 0.3, 0.5, and 0.7. For alpha = 0.2 we got Ps = -100.04, for alpha = 0.3 we got Ps = -98.06, for alpha = 0.5 we got Ps = -96.04, for alpha = 0.7 we got Ps = -94.06.

4.16 Plots of P_s vs. alpha:

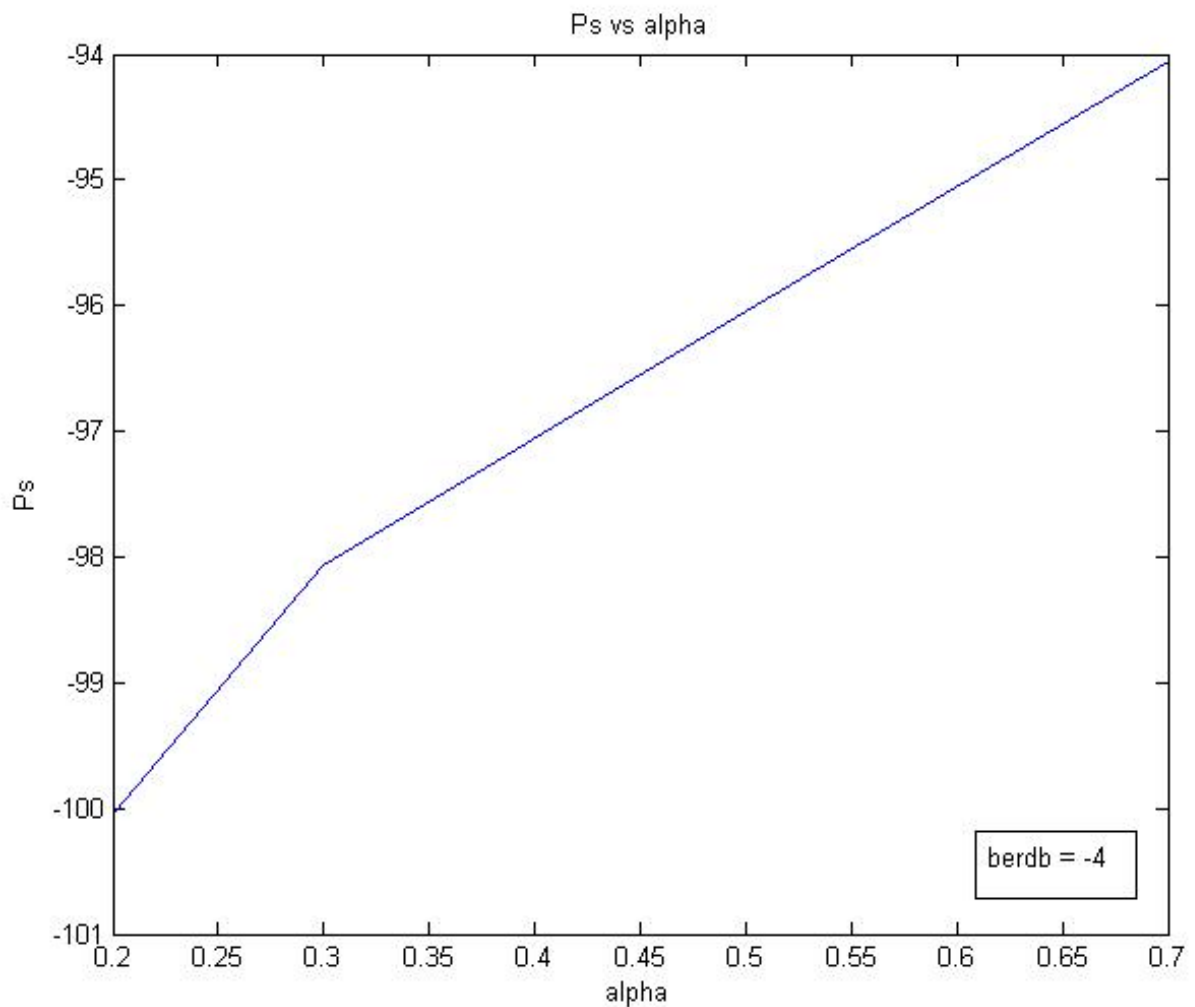

Figure 29: P_s vs. alpha

Here we see the plot between the signal powers (P_s) vs. alpha. If we increase the value of alpha then ultimately the signal power (P_s) will be increase. For this plot we consider berdb as -4.

4.17 Plots of BER vs. Nu:

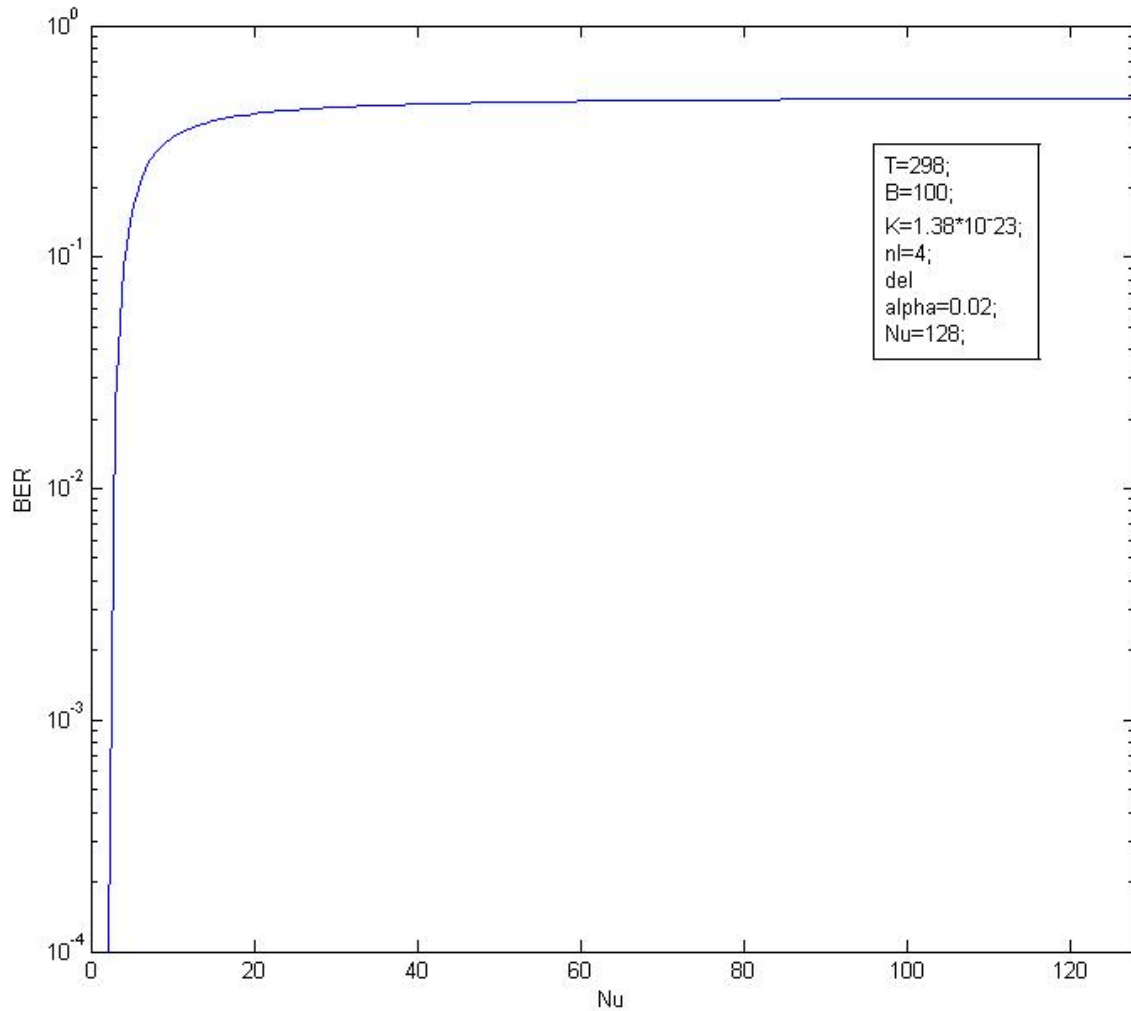

Figure 30: BER vs. Nu

Here, we can see the plot between the numbers of user (Nu) vs. unconditional Bit error rate (BER). If we increase the number of user (Nu) the bit error rate (BER) will be increase. After reach in nee point the bit error rate is getting fixed. We have used the formula of unconditional bit error rate. Here the number of user (Nu) is 128 and each user divided into 1000. So the lenth of each gap here we called del_alpha.

4.18 Plots of BER vs. Nu (with value of Nc):

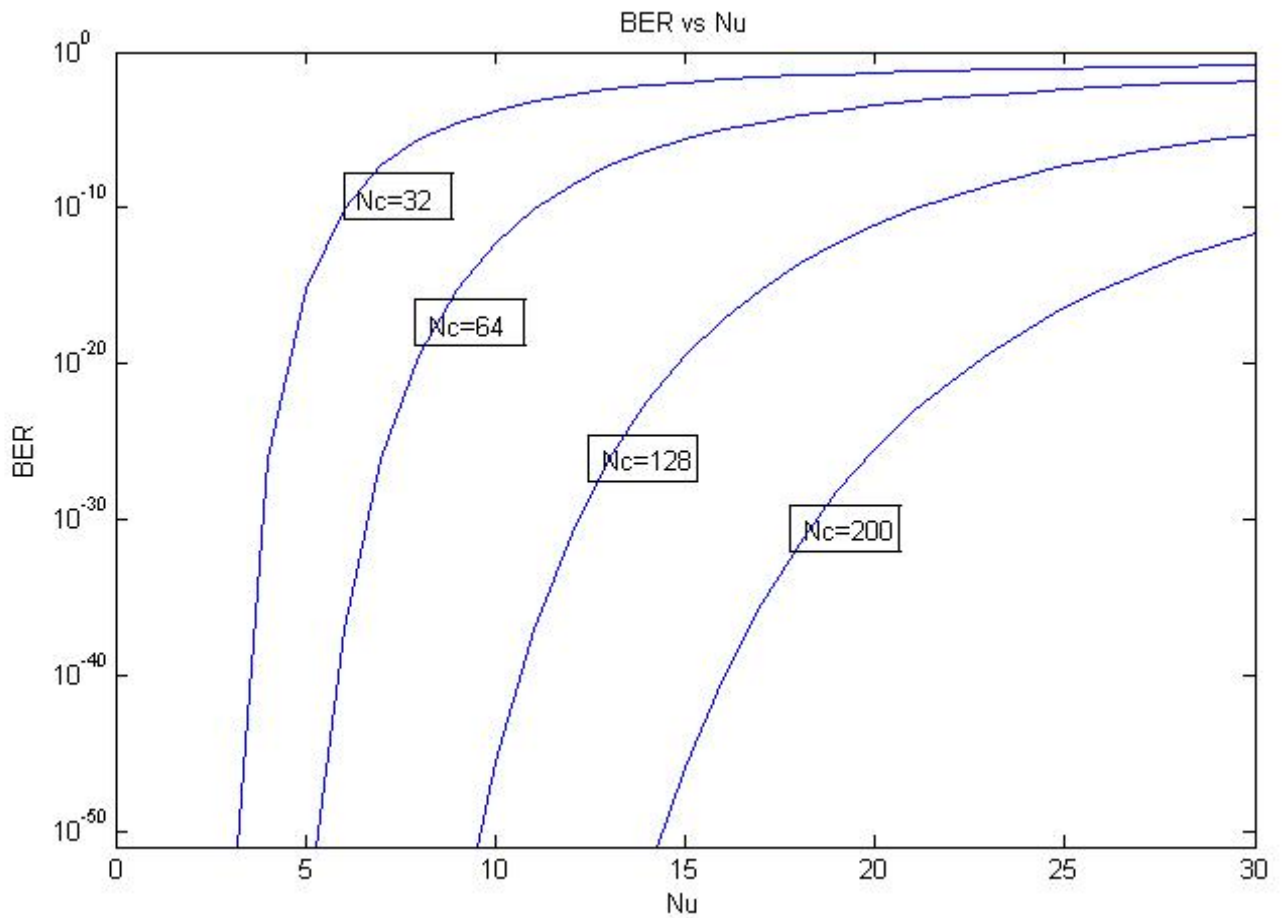

Figure 31: BER vs. Nu (with value of Nc)

Here we can also see that the plot between the Number of user (Nu) vs. unconditional Bit error rate (BER). In this plot, we consider the number of sub-carrier (N_c) and vary this into different values such as $N_c= 32, 64, 128, 200$.

4.19 Plots of BER vs. Nu (cut BER from 10^{-15}):

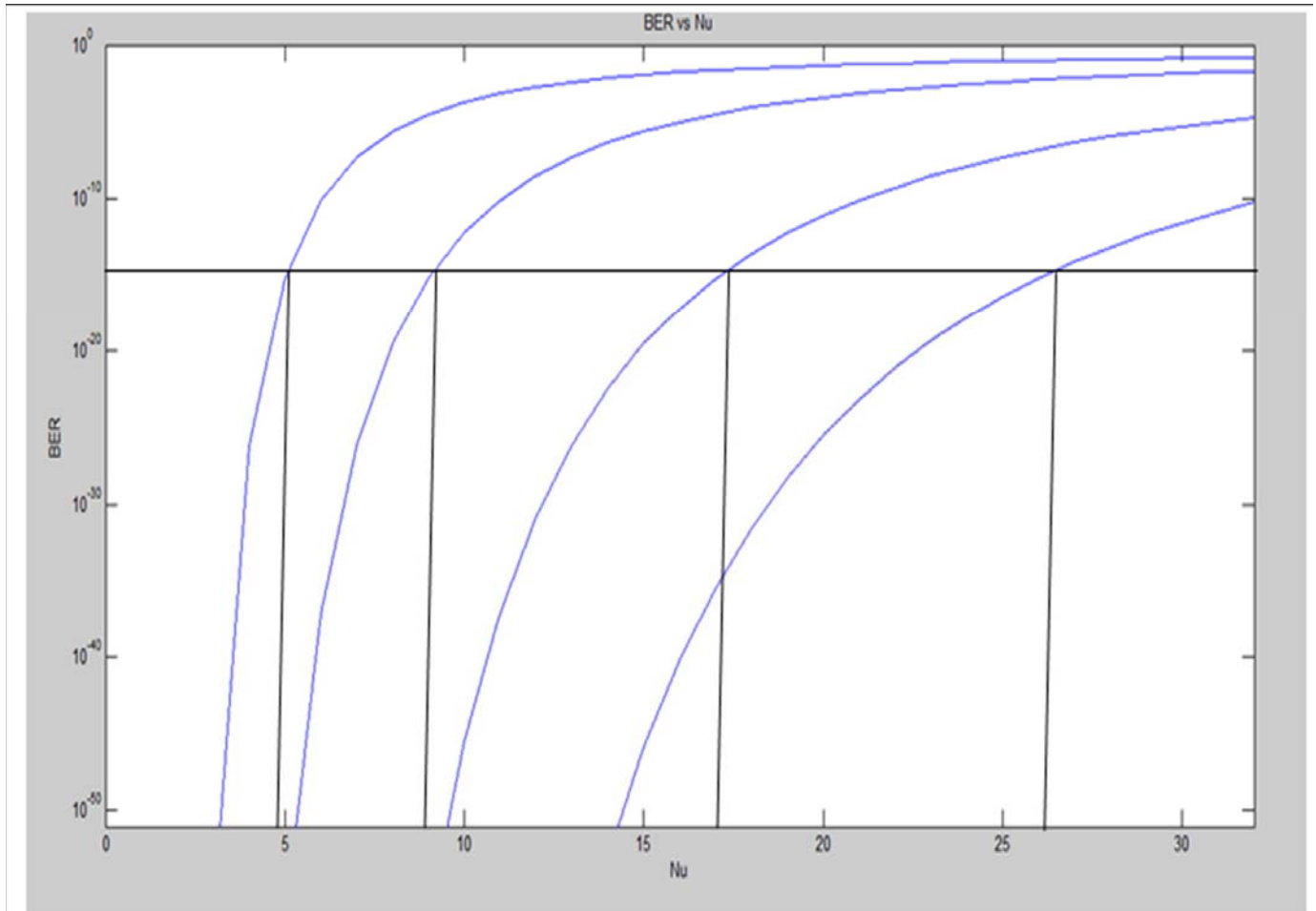

Figure 32: BER vs. Nu (cut BER from 10^{-15})

Here we can see the plot between BER vs Nu. If we draw a axis which is parallel to Nu from a particular BER 10^{-15} , we can see that the axis intersects the N_c curve at 32, 64, 128 and 200. For the value of $N_c = 32$ we got Nu = 4.9, for $N_c = 64$ we got Nu = 9, for $N_c = 128$ we got Nu = 17, for $N_c = 200$ we got Nu = 26.

4.20 Plots of Nu vs. Nc:

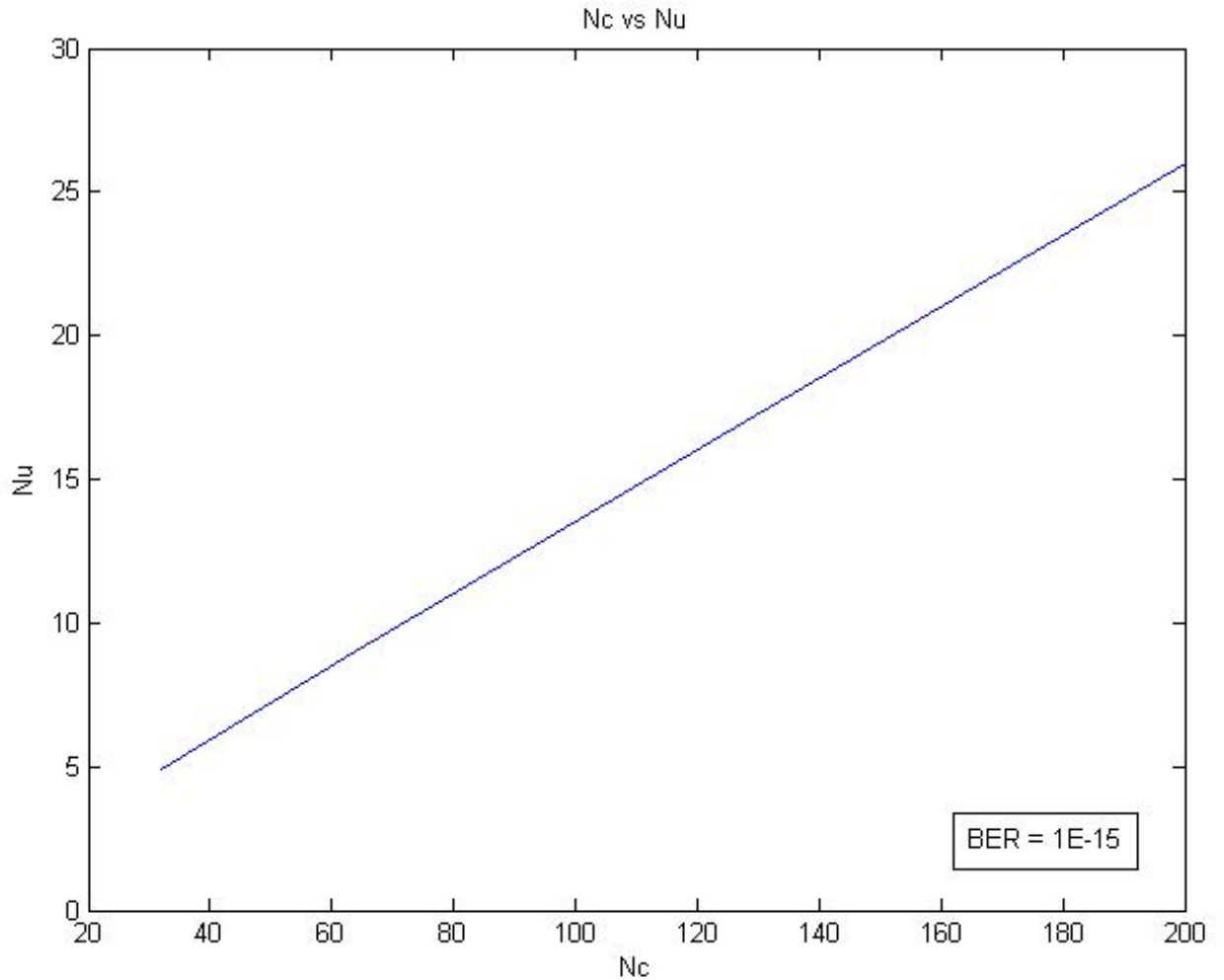

Figure 33: Nu vs. Nc

This plot is from the previous graph. For different values of N_u we got different values of N_c . Here the conditional bit error rate is 10^{-15} . If we increase the number of sub-carrier (N_c) then the number of users (N_u) will be also be increase.

CHAPTER 5

Conclusion and Future work on MC DS CDMA with Fading

5.1 Conclusion:

This thesis paper reviews Multicarrier based CDMA schemes such as MC CDMA, DS CDMA and MC DS CDMA with the effect of fading and discuss about their some features. This paper is basically focused on the MC DS CDMA system and its analysis with fading. In this paper we derive a completely new equation for multiple access interference (MAI) and by using Matlab we find some plots to verify whether the equations are correct or not and then explain.

5.2 Future Works:

Further works can be carried out

1. To evaluate the effect of timing jitter in a MC CDMA system in the presence of fading.
2. To evaluate the performance of MC CDMA system with Rake receiver to overcome the effect of fading.
3. To find the performance limitations due to non-orthogonality among the subcarriers (due to imperfect carrier synchronization).
4. To evaluate the performance improvement with forward error correction coding like convolution coding and Turbo coding etc.

5.3 Reference:

1. Jean-Paul M. G. Linnartz – “Performance Analysis of Synchronous MC- CDMA in Mobile Rayleigh Channel with Both Delay and Doppler Spreads”, IEEE transactions on vehicular technology, vol. 50, no. 6, November 2001
2. Vijay K. Garg - “Wireless Communication and Networking”
3. Theodore S. Rappaport – “Wireless Communications principle and practice”

4. Saimoon Ara Amin and Md.Mahbubul Alam – “Performance analyses of Multi-Carrier DS-CDMA wireless communication systems.”

5. <http://en.wikipedia.org>

6. <http://www.wirelesscommunication.nl>

7. <http://www.telecomspace.com>

8. <http://wireless.ictp.it>

9. <http://www.newwaveinstruments.com>

10. <http://www.ece.unm.edu>

12. www.ieee.org

Matlab for figure 14:

```
T=298;
B=100;
K=1.38*10^-23;
alpha=1;
nl=4;
j=[2 10 18 26 34 42 50 58 66 74 82 90 98 106];
ps=1*10^-3;
for i=1:14
SIR1(i)=(0.5*(alpha^2)*(ps^2)*(nl^2));
SIR2(i)=(0.5*(alpha^2)*(ps^2)*(j(i)-1)^2)+K*T*B;
SIR(i)=SIR1(i)/SIR2(i);
end
semilogy(j,SIR);
```

Matlab for 15:

```
T=298;
B=100;
K=1.38*10^-23;
alpha=1;
nl=4;
j=[2 10 18 26 34 42 50 58 66 74 82 90 98 106];
ps=1*10^-3;
for i=1:14
SIR1(i)=(0.5*(alpha^2)*(ps^2)*(nl^2));
SIR2(i)=(0.5*(alpha^2)*(ps^2)*(j(i)-1)^2)+K*T*B;
SIR(i)=SIR1(i)/SIR2(i);
End
```

```
semilogy(j,SIR);
hold on
T=298;
B=100;
K=1.38*10^-23;
alpha=1;
nl=10;
j=[2 10 18 26 34 42 50 58 66 74 82 90 98 106];
ps=1*10^-3;
for i=1:14
SIR1(i)=(0.5*(alpha^2)*(ps^2)*(nl^2));
SIR2(i)=(0.5*(alpha^2)*(ps^2)*(j(i)-1)^2)+K*T*B;
SIR(i)=SIR1(i)/SIR2(i);
end
semilogy(j,SIR);
hold on
T=298;
B=100;
K=1.38*10^-23;
alpha=1;
nl=18;
j=[2 10 18 26 34 42 50 58 66 74 82 90 98 106];
ps=1*10^-3;
```

```

for i=1:14
SIR1(i)=(0.5*(alpha^2)*(ps^2)*(nl^2));
SIR2(i)=(0.5*(alpha^2)*(ps^2)*(j(i)-1)^2)+K*T*B;
SIR(i)=SIR1(i)/SIR2(i);
end
semilogy(j,SIR);
hold on
T=298;
B=100;
K=1.38*10^-23;
alpha=1;
nl=30;
j=[2 10 18 26 34 42 50 58 66 74 82 90 98 106];
ps=1*10^-3;
for i=1:14
SIR1(i)=(0.5*(alpha^2)*(ps^2)*(nl^2));
SIR2(i)=(0.5*(alpha^2)*(ps^2)*(j(i)-1)^2)+K*T*B;
SIR(i)=SIR1(i)/SIR2(i);
end
semilogy(j,SIR);

```

Matlab for figure 17:

```

SIR = 10^1;
j = [3 6 8 11];
Nc = [4 10 18 30];
plot (j,Nc);

```

Matlab fo figure 18:

```

T=298;

```

```
B=100*10^6;
K=1.38*10^-23;
alpha=0.8;
nl=12;
j=10;
ps=[-75 -70 -65 -60 -55 -50 -45 -40 -35];
for i=1:9
    p_s(i)=10^(ps(i)/10);
end
for i=1:9
    SIR1(i)=(0.5*(alpha^2)*(p_s(i)^2)*(nl^2));
    SIR2(i)= K*T*B;
    SIR3(i)=(0.5*(alpha^2)*(p_s(i)^2)*(j-1)^2)
    SIR(i)=SIR1(i)/(SIR3(i)+SIR2(i));
    SIRdb(i)= 10*log10(SIR(i));
end
plot(ps,SIRdb);
```

Matlab for figure 19:

```
T=298;
B=100*10^6;
K=1.38*10^-23;
alpha=0.8;
nl=12;
j=10;
ps=[-75 -70 -65 -60 -55 -50 -45 -40 -35];
for i=1:9
    p_s(i)=10^(ps(i)/10);
```

```
end
for i=1:9
SIR1(i)=(0.5*(alpha^2)*(p_s(i)^2)*(nl^2));
SIR2(i)= K*T*B;
SIR3(i)=(0.5*(alpha^2)*(p_s(i)^2)*(j-1)^2)
SIR(i)=SIR1(i)/(SIR3(i)+SIR2(i));
SIRdb(i)= 10*log10(SIR(i));
end
plot(ps,SIRdb);
hold on
T=298;
B=100*10^6;
K=1.38*10^-23;
alpha=0.8;
nl=12;
j=15;
ps=[-75 -70 -65 -60 -55 -50 -45 -40 -35];
for i=1:9
p_s(i)=10^(ps(i)/10);
end
for i=1:9
SIR1(i)=(0.5*(alpha^2)*(p_s(i)^2)*(nl^2));
SIR2(i)= K*T*B;
SIR3(i)=(0.5*(alpha^2)*(p_s(i)^2)*(j-1)^2)
SIR(i)=SIR1(i)/(SIR3(i)+SIR2(i));
SIRdb(i)= 10*log10(SIR(i));
end
```



```
plot(ps,SIRdb);
hold on
T=298;
B=100*10^6;
K=1.38*10^-23;
alpha=0.8;
nl=12;
j=20;
ps=[-75 -70 -65 -60 -55 -50 -45 -40 -35];
for i=1:9
    p_s(i)=10^(ps(i)/10);
end
for i=1:9
    SIR1(i)=(0.5*(alpha^2)*(p_s(i)^2)*(nl^2));
    SIR2(i)= K*T*B;
    SIR3(i)=(0.5*(alpha^2)*(p_s(i)^2)*(j-1)^2)
    SIR(i)=SIR1(i)/(SIR3(i)+SIR2(i));
    SIRdb(i)= 10*log10(SIR(i));
end
plot(ps,SIRdb);
hold on
T=298;
B=100*10^6;
K=1.38*10^-23;
alpha=0.8;
nl=12;
```

```

j=25;
ps=[-75 -70 -65 -60 -55 -50 -45 -40 -35];
for i=1:9
    p_s(i)=10^(ps(i)/10);
end
for i=1:9
    SIR1(i)=(0.5*(alpha^2)*(p_s(i)^2)*(nl^2));
    SIR2(i)= K*T*B;
    SIR3(i)=(0.5*(alpha^2)*(p_s(i)^2)*(j-1)^2)
    SIR(i)=SIR1(i)/(SIR3(i)+SIR2(i));
    SIRdb(i)= 10*log10(SIR(i));
end
plot(ps,SIRdb);
hold on

```

Matlab for figure 21:

```

SIRbd = -7;
j = [10 15 20 25];
ps = [-73.2 -72.6 -71.5 -70.1];
plot (j,ps);

```

Matlab for 22:

```

alpha=0.2;
j=[2 10 18 26 34 42 50 58 66 74 82 90 98 106];
ps=1*10^-3;
for i=1:14
    ICI(i)=(0.5*(alpha^2)*(ps^2)*(j(i)-1)^2);
end
semilogy(j,ICI);

```

Matlab for figure 23:

```
alpha=.2;
j=[2 10 18 26 34 42 50 58 66 74 82 90 98 106];
ps=1*10^-3;
for i=1:14
ICI(i)=(0.5*(alpha^2)*(ps^2)*(j(i)-1)^2);
end
semilogy(j,ICI);
hold on
alpha=.5;
j=[2 10 18 26 34 42 50 58 66 74 82 90 98 106];
ps=1*10^-3;
for i=1:14
ICI(i)=(0.5*(alpha^2)*(ps^2)*(j(i)-1)^2);
end
semilogy(j,ICI);
hold on
alpha=.7;
j=[2 10 18 26 34 42 50 58 66 74 82 90 98 106];
ps=1*10^-3;
for i=1:14
ICI(i)=(0.5*(alpha^2)*(ps^2)*(j(i)-1)^2);
end
semilogy(j,ICI);
hold on
alpha=.9;
j=[2 10 18 26 34 42 50 58 66 74 82 90 98 106];
```

```
ps=1*10^-3;
for i=1:14
ICI(i)=(0.5*(alpha^2)*(ps^2)*(j(i)-1)^2);
end
semilogy(j,ICI);
```

Matlab for 25:

```
ICI = 10^-5;
j = [7 9 10 24];
alpha = [0.9 0.7 0.5 0.2];
plot (j,alpha);
```

Matlab for figure 26:

```
clc;
clear all;
T=298;
B=100;
K=1.38*10^-23;
alpha=0.2;
nl=4;
j=10;
ps=[-108 -106 -104 -102 -100 -98 -96 -94 -92];
for i=1:9
p_s(i)=10^(ps(i)/10);
end
for i=1:9
SIR1(i)=(0.5*(alpha^2)*(p_s(i)^2)*(nl^2));
SIR2(i)= K*T*B;
SIR3(i)=(0.5*(alpha^2)*(p_s(i)^2)*(j-1)^2)
```

```
SIR(i)=SIR1(i)/(SIR3(i)+SIR2(i));
```

```
ber(i)=0.5*erfc(sqrt(SIR(i)/2));
```

```
berdb(i)=10*log10(ber(i));
```

```
end
```

```
plot(ps,berdb);
```

Matlab for figure 27:

```
T=298;
```

```
B=100;
```

```
K=1.38*10^-23;
```

```
alpha=0.2;
```

```
nl=4;
```

```
j=10;
```

```
ps=[-108 -106 -104 -102 -100 -98 -96 -94 -92];
```

```
for i=1:9
```

```
  p_s(i)=10^(ps(i)/10);
```

```
end
```

```
for i=1:9
```

```
  SIR1(i)=(0.5*(alpha^2)*(p_s(i)^2)*(nl^2));
```

```
  SIR2(i)= K*T*B;
```

```
  SIR3(i)=(0.5*(alpha^2)*(p_s(i)^2)*(j-1)^2)
```

```
  SIR(i)=SIR1(i)/(SIR3(i)+SIR2(i));
```

```
  ber(i)=0.5*erfc(sqrt(SIR(i)/2));
```

```
  berdb(i)=10*log10(ber(i));
```

```
end
```

```
plot(ps,berdb);
```

```
hold on
```

```
T=298;
B=100;
K=1.38*10^-23;
alpha=0.3;
nl=4;
j=10;
ps=[-108 -106 -104 -102 -100 -98 -96 -94 -92];
for i=1:9
    p_s(i)=10^(ps(i)/10);
end
for i=1:9
    SIR1(i)=(0.5*(alpha^2)*(p_s(i)^2)*(nl^2));
    SIR2(i)= K*T*B;
    SIR3(i)=(0.5*(alpha^2)*(p_s(i)^2)*(j-1)^2)
    SIR(i)=SIR1(i)/(SIR3(i)+SIR2(i));
    ber(i)=0.5*erfc(sqrt(SIR(i)/2));
    berdb(i)=10*log10(ber(i));
end
plot(ps,berdb);
hold on
T=298;
B=100;
K=1.38*10^-23;
alpha=0.5;
nl=4;
j=10;
```

```
ps=[-108 -106 -104 -102 -100 -98 -96 -94 -92];
for i=1:9
p_s(i)=10^(ps(i)/10);
end
for i=1:9
SIR1(i)=(0.5*(alpha^2)*(p_s(i)^2)*(nl^2));
SIR2(i)= K*T*B;
SIR3(i)=(0.5*(alpha^2)*(p_s(i)^2)*(j-1)^2)
SIR(i)=SIR1(i)/(SIR3(i)+SIR2(i));
ber(i)=0.5*erfc(sqrt(SIR(i)/2));
berdb(i)=10*log10(ber(i));
end
plot(ps,berdb);
hold on
T=298;
B=100;
K=1.38*10^-23;
alpha=0.7;
nl=4;
j=10;
ps=[-108 -106 -104 -102 -100 -98 -96 -94 -92];
for i=1:9 p_s(i)=10^(ps(i)/10);
end
for i=1:9
SIR1(i)=(0.5*(alpha^2)*(p_s(i)^2)*(nl^2));
SIR2(i)= K*T*B;
SIR3(i)=(0.5*(alpha^2)*(p_s(i)^2)*(j-1)^2)
```

```
SIR(i)=SIR1(i)/(SIR3(i)+SIR2(i));
```

```
ber(i)=0.5*erfc(sqrt(SIR(i)/2));
```

```
berdb(i)=10*log10(ber(i));
```

```
endplot(ps,berdb);
```

Matlab for 29:

```
berdb = -4;
```

```
Ps = [ -100.04 -98.06 -96.04 -94.06];
```

```
alpha = [ 0.2 0.3 0.5 0.7];
```

```
plot (alpha,Ps);
```

Matlab for 30:

```
clc;
```

```
clear all;
```

```
close all;
```

```
T=298;
```

```
B=100;
```

```
K=1.38*10^-23;
```

```
nl=4;
```

```
j=0;
```

```
BER = 0;
```

```
sig = sqrt(0.01);
```

```
del_alpha=0.02;
```

```
Nu=128;
```

```
for j=1:Nu
```

```
ber=0;
```

```
p=0;
```

```
for i=1:1000
```

```
alpha(i) = (i-1)*del_alpha;
```



```

ps=0.001;
SIR1(i)=(0.5*(alpha(i)^2)*(ps^2)*(nl^2));
SIR2 = K*T*B;
SIR3(i)=(0.5*(alpha(i)^2)*(ps^2)*(j-1)^2);
SIR(i) = SIR1(i)/(SIR3(i) + SIR2);
ber(i) = 0.5*erfc(sqrt(SIR(i)/2));
x(i)=alpha(i);
p(i) = ((x(i) * exp(-1 * x(i)^2 / (2 * sig^2))) / sig^2);
end
y=ber.*p;
BER(j) = trapz(y)*del_alpha;
End
semilogy(1:Nu,BER)

```

Matlab for figure 31:

```

clc;
clear all;
close all;
T=298;
B=100;
K=1.38*10^-23;
nl=32;
j=0;
BER = 0;
sig = sqrt(0.01);
del_alpha=0.02;
Nu=32;
for j=1:Nu

```

```
ber=0;
p=0;
for i=1:1000
alpha(i) = (i-1)*del_alpha;
ps=0.001;
SIR1(i)=(0.5*(alpha(i)^2)*(ps^2)*(nl^2));
SIR2 = K*T*B;
SIR3(i)=(0.5*(alpha(i)^2)*(ps^2)*(j-1)^2);
SIR(i) = SIR1(i)/(SIR3(i) + SIR2);
ber(i) = 0.5*erfc(sqrt(SIR(i)/2));
x(i)=alpha(i);
p(i) = ((x(i) * exp(-1 * x(i)^2 / (2 * sig^2))) / sig^2);
end
y=ber.*p;
BER(j) = trapz(y)*del_alpha;
End
semilogy(1:Nu,BER)
hold on
T=298;
B=100;
K=1.38*10^-23;
nl=64;
j=0;
BER = 0;
sig = sqrt(0.01);
del_alpha=0.02;
Nu=32;
```

```
for j=1:Nu
ber=0;
p=0;
for i=1:1000
alpha(i) = (i-1)*del_alpha;
ps=0.001;
SIR1(i) =(0.5*(alpha(i)^2)*(ps^2)*(nl^2));
SIR2 = K*T*B;
SIR3(i) =(0.5*(alpha(i)^2)*(ps^2)*(j-1)^2);
SIR(i) = SIR1(i) /(SIR3(i) + SIR2);
ber(i) = 0.5*erfc(sqrt(SIR(i)/2));
x(i)=alpha(i);
p(i) =((x(i) * exp(-1 * x(i)^2 / (2 * sig^2))) / sig^2);
end
y=ber.*p;
BER(j) = trapz(y)*del_alpha;
end
semilogy(1:Nu,BER)
hold on
T=298;
B=100;
K=1.38*10^-23;
nl=128;
j=0;
BER = 0;
sig = sqrt(0.01);
del_alpha=0.02;
```

```
Nu=32;
for j=1:Nu
ber=0;
p=0;
for i=1:1000
alpha(i) = (i-1)*del_alpha;
ps=0.001;
SIR1(i) =(0.5*(alpha(i)^2)*(ps^2)*(nl^2))
SIR2 = K*T*B;
SIR3(i) =(0.5*(alpha(i)^2)*(ps^2)*(j-1)^2);
SIR(i) = SIR1(i) /(SIR3(i) + SIR2);
ber(i) = 0.5*erfc(sqrt(SIR(i)/2));
x(i)=alpha(i);
p(i) =((x(i) * exp(-1 * x(i)^2 / (2 * sig^2))) / sig^2);
end
y=ber.*p;
BER(j) = trapz(y)*del_alpha;
End
semilogy(1:Nu,BER)
hold on
T=298;
B=100;
K=1.38*10^-23;
nl=200;
j=0;
BER = 0;
sig = sqrt(0.01);
```

```

del_alpha=0.02;
Nu=32;
for j=1:Nu
    ber=0;
    p=0;
    for i=1:1000
        alpha(i) = (i-1)*del_alpha
        ps=0.001;
        SIR1(i)=(0.5*(alpha(i)^2)*(ps^2)*(nl^2));
        SIR2 = K*T*B;
        SIR3(i)=(0.5*(alpha(i)^2)*(ps^2)*(j-1)^2);
        SIR(i) = SIR1(i)/(SIR3(i) + SIR2);
        ber(i) = 0.5*erfc(sqrt(SIR(i)/2));
        x(i)=alpha(i);
        p(i) = ((x(i) * exp(-1 * x(i)^2 / (2 * sig^2))) / sig^2);
    end
    y=ber.*p;
    BER(j) = trapz(y)*del_alpha;
end
semilogy(1:Nu,BER)

```

Matlab for figure 33:

```

BER = 10^-15;
Nu = [ 4.9 9 17 26];
Nc = [ 32 64 128 200];
plot (Nc,Nu);

```