

**POWER CONSERVATION FOR
ELECTRICALLY ASSISTED RICKSHAW-VANS
WITH PV SUPPORT, TORQUE SENSOR PEDAL
AND THE SOLAR BATTERY CHARGING
STATION - A Complete Off-Grid Solution
(Conducting field tests and data analysis for
performance and feasibility study)**



Inspiring Excellence

**A Thesis Submitted to the Department of Electrical and Electronic
Engineering of BRAC University**

By

**Fabiha Roshni Khan- ID 11321004
Ataur Rahman -ID 11321015
Anika Tasnim Aurony- ID 11321009**

Supervised by

**Dr. A. K. M. Abdul Malek Azad
Professor
Department of Electrical and Electronic Engineering
BRAC University, Dhaka.**

**In partial fulfilment of the requirements for the degree of Bachelor of
Science in Electrical and Electronic Engineering**

**Summer 2015
BRAC University, Dhaka**

DECLARATION

We hereby declare that our research titled “Power conservation for electrically assisted rickshaw-vans with PV support, torque sensor pedal and the solar battery charging station- A complete off-grid solution. (Conducting field tests and data analysis for performance and feasibility study)”, a thesis submitted to the Department of Electrical and Electronics Engineering of BRAC University in partial fulfilment of the Bachelors of Science in Electrical and Electronics Engineering, is our own work. The work has not been presented elsewhere for assessment. The materials collected from other sources have been acknowledged here

Signature of Supervisor

Signature of Author

.....

Dr. A. K. M. Abdul Malek Azad

.....

Fabiha Roshni Khan

Signature of Co-Authors

.....

Ataur Rahman

.....

Anika Tasnim Aurony

ACKNOWLEDGEMENT

We are thankful to our thesis supervisor Dr. A.K.M. Abdul Malek Azad , Professor, Dept. of Electrical and Electronic Engineering (EEE), BRAC University, for his guidance for completion of the thesis. Regards to our Project Engineer, Sheri Jahan Chowdhury for her support throughout the whole thesis time span. We are thankful to EEE department, BRAC University for providing us the necessary equipment for the completion of this project and funding this project undertaken by Control and Application Research Centre (CARC).

ABSTRACT

Rickshaw-vans are the most popular form of transportation in the cities as well as rural areas of Bangladesh. A significant number of people of Bangladesh are directly or indirectly dependent upon this rickshaw-van pulling profession. This paper describes a research to modernize the pollution free rickshaw-van, aiming to improve the lifestyle and income of the rickshaw-pullers and reduce stress on the health of the pullers. The modernized rickshaw-van used in our experiment causes no carbon emission and thus it is eco-friendly. The electrically assisted rickshaw-van consists of torque sensor pedal in order to reduce the over-use of battery-bank. The control system assists the human power with motor and saves energy by reducing the over-use of motor. PV panel is installed on the rooftop of van to share the load power and a solar battery charging station is implemented to make the whole system completely independent of national grid. The paper describes the data obtained from field test to determine its performance, feasibility and user friendliness. The solar battery charging station is designed and its performance analysis is included as well. The hybrid “green” rickshaw-van was developed to save energy, use sufficient solar energy and make it a complete off grid solution.

TABLE OF CONTENTS

Acknowledgement	ii
Abstract	iii
List of Figures	viii
List of Tables	xi
List of Abbreviations	xii
CHAPTER 1: Introduction	1
1.1 Introduction to Rickshaw- van.....	1
1.2 Impact of Rickshaw Vans in the Economy of Bangladesh.....	2
1.3 Motivation.....	3
1.4 Overview of contents.....	3
CHAPTER 2: Overview of the Whole System	4
2.1 Introduction.....	4
2.2 Components used.....	6
2.2.1 The Batteries.....	6
2.2.2 The Motor.....	7
2.2.3 The Controller Box.....	7
2.2.4 The Throttle.....	8
2.2.5 The Power Key and Charge Indicator.....	9
2.2.6 The Solar Panel.....	10
2.2.7 The Charge Controller.....	10
2.2.8 The Torque Sensor.....	11
2.2.9 The Brake System	11
2.2.10 The Handle.....	13
2.2.11 The Light system.....	14
2.3 Wiring of the Whole System.....	16
2.4 Conclusion.....	16
CHAPTER 3: Chronological Development of Rickshaw	17
3.1 Introduction.....	17
3.2 Traditional Rickshaw	17
3.3 Beevatech Model and Boraq Model of Electric Rickshaw	18
3.4 Torque Sensor Based Electrically Assisted Rickshaw.....	19
3.5 Electric Rickshaw with PV support.....	19

3.6 Rickshaw-van with PV support, torque sensor pedal.....	20
3.7 Conclusion.....	21
CHAPTER 4: Integrating Torque Sensor and PV Array into the System.....	22
4.1 Introduction	22
4.2 Introduction to the Torque Sensor.....	22
4.3 Types of Torque Transducers and Torque Sensors.....	22
4.4 Applications	23
4.5 Features of Torque Sensor	23
4.6 Technical Parameter Data	24
4.7 Electrical Connections.....	24
4.8 Power Management	26
4.9 Lab-Condition Testing of the Whole System.....	28
4.10 Design-I	28
4.10.1. Introduction	28
4.10.2 The Circuit-Diagram and Explanation	28
4.10.3. Simulation and Results.....	29
4.10.4. Sensor Simulation Data	30
4.11 Design-II	31
4.11.1. Introduction.....	31
4.11.2 The Circuit-Diagram and Explanation.....	31
4.11.3. Sensor Simulation Data	32
4.12 Comments.....	33
4.13 Integrating both Torque Sensor and PV Array in the System.....	34
4.13.1 Specification of PV Array.....	34
4.14 Control Algorithm.....	35
4.15 Conclusion.....	37
CHAPTER 5: Overview of the Solar Battery Charging Station.....	38
5.1 Introduction to the Solar Battery Charging Station.....	38
5.2 Operation of Solar Battery Charging Station.....	39
5.3 SOC of the Battery.....	40
5.4 Data obtained from Solar Battery Charging Station.....	41
5.5 Conclusion.....	42

CHAPTER 6: Easy Swapping of the Batteries from Tri-wheeler to Solar Charging Station and vice-versa..... 43

6.1 Introduction.....43
6.2 Current Swapping System.....43
6.3 Limitations of conventional swapping system.....44
6.4 Proposed Design-I:.....46
6.4.1 Introduction.....46
6.4.2 Roller System underneath the Batteries.....46
6.4.3 Adjustable Trolley.....47
6.4.4 Mechanism.....49
6.4.5 Advantage of proposed Design-I.....50
6.5 Proposed Design-II:.....50
6.5.1 Introduction.....50
6.5.2 Actuator and tray based Trolley Table51
6.5.3 Mechanism52
6.5.4 Advantage of Proposed Design-II52
6.6 Comments.....53
6.7 Conclusion.....53

CHAPTER 7: Field test54

7.1 Objectives54
7.2 Data Acquisition Technique.....54
7.3 Field Test Data without PV support and Torque Sensor55
7.4 Field Test Data with PV Support only.....57
7.5 Field Test Data with Torque Sensor only.....60
7.6 Field Test Data with both PV Support and Torque Sensor.....62
7.7 Comparative Study.....65
7.7.1 With PV Support only Vs. Without PV Support and Torque Sensor.....65
7.7.2 Without PV Support and Torque Sensor Vs. With Torque Sensor.....66
7.7.3 Without PV Support and Torque Sensor Vs. With both PV Support and Torque Sensor..69
7.8 Conclusion.....72

CHAPTER 8: Conclusion.....73

8.1 Summary.....73
8.2 Future Work.....73

REFERENCES.....75

APPENDIX.....	77
Appendix A Wiring Diagram	78
Appendix B Flow Diagram of Chronological Development of Rickshaw.....	79
Appendix C Field Test Data without PV Support and Torque Sensor Pedal.....	80
Appendix D Field Test Data with PV Support only.....	85
Appendix E Field Test Data with Torque Sensor only.....	92
Appendix F Field Test Data with both PV Support and Torque Sensor.....	102
Appendix G Training Manual.....	116

LIST OF FIGURES

Fig 1.1 Rickshaws in use today

Fig 1.2 Rickshaw-van

Fig 1.3 Rickshaw van for school going children

Fig 2.1 Side-view

Fig 2.2 Front-view

Fig 2.3 Back-view

Fig 2.4 Top view

Fig 2.5 Two batteries

Fig 2.6 BLDC motor

Fig 2.7 Controller box

Fig 2.8 Identification of the controller cables

Fig 2.9 Throttle

Fig 2.10 Power key and charge indicator

Fig 2.11 Solar panel

Fig 2.12 Charge controller

Fig 2.13 Torque sensor

Fig 2.14 Hand-clutch

Fig 2.15 Rear wheel brake

Fig 2.16 Traditional hand-clutch

Fig 2.17 Cabin handle

Fig 2.18 Headlight

Fig 2.19 Indicator, brake light and reflector

Fig 2.20 Brake light is on

Fig 2.21 Left indicator is on

Fig2.22 LED cabin light

Fig 3.1 Traditional rickshaw

Fig 3.2 Beevatech model of electric rickshaw

Fig 3.3 Torque sensor based electric rickshaw

Fig 3.4 Electric rickshaw with PV panel installed in “flat state”

Fig 3.5 Rickshaw-van with torque sensor pedal and PV support

Fig 4.1 Complete set-view of Torque Sensor and other components

Fig 4.2 Torque Sensor and Module

Fig 4.3 The torque-sensor pedal

Fig 4.4 Electrical Connection diagram for independent operation of the sensor and module

Fig 4.5 Complete overview of the power management and signal flow

Fig 4.6 Hardware implementation of the system in PCB

Fig 4.7 Circuit Diagram for Design-I

Fig 4.8 Circuit Diagram of the System for Design-II

Fig 4.9 Solar panel on rickshaw-pan

Fig 4.10 Block diagram of the whole operation

Fig 4.11 Flowchart of the whole system

Fig 5.1 SBCS on the rooftop of BRAC University building 2

Fig 5.2 Solar battery charging station concept

Fig 5.3 Functional block diagram of SBCS

Fig 5.4 SBCS supply profile

Fig 5.5 Total battery voltage (volts) vs time (seconds)

Fig.6.1 Side and rear view of solar Tri-Wheeler

Fig.6.2 Conventional trolley used to transport load

Fig.6.3 Solar Tri-Wheeler

Fig.6.4 Roller system used to swap batteries

Fig.6.5 The skeleton of the roller system

Fig.6.6 The proposed new design of the Trolley

Fig.6.7 12 volt Actuator

Fig.6.8 Actuator and tray based Trolley

Fig 7.1 Data acquisition technique

Fig 7.2 Battery supply profile

Fig 7.3 Battery power (watts) vs. time (seconds)

Fig 7.4 Load power (watts) vs. time (seconds) without PV support and torque sensor

Fig 7.5 The PV array supply profile

Fig 7.6 The battery supply profile with PV support

Fig 7.7 The load profile of the rickshaw-van with PV support

Fig 7.8 Comparison of load power (watts), battery power (watts) and panel power (watts) with respect to time (seconds)

Fig 7.9 Comparison of torque sensor output voltage (volts) from the pedal to the torque adjuster circuit and input voltage(volts) from torque adjuster circuit to controller unit with respect to time (seconds)

Fig 7.10 The battery supply profile with torque sensor pedal

Fig 7.11 Battery power (watts) Vs time (seconds)

Fig 7.12 Load power (watts) Vs time (seconds)

Fig 7.13 PV array supply profile

Fig 7.14 Battery supply profile

Fig 7.15 Load Profile

Fig 7.16 Comparison of panel power (watts), load power (watts) and battery power (watts) vs time (seconds)

Fig 7.17 Power contribution of battery and panel

Fig 7.18 Projected distance of the rickshaw-van upto 50% DOD of the battery

Fig 7.19 Projected distance of the rickshaw-van upto 50% DOD of the battery

Fig 7.20 Comparison of battery power consumed with throttle system and torque sensor

Fig 7.21 Comparison between energy saved with torque sensor and without PV support and torque sensor

Fig 7.22 Projected distance of the rickshaw-van upto 50% DOD of the battery

Fig 7.23 Comparison between energy consumed and energy saved with torque sensor and with both PV support and torque sensor

Fig 7.24 Comparison of distance travelled by the rickshaw-van upto 50% DOD

Fig 7.25 Energy contribution of battery panel and torque sensor

Fig 8.1 Extra features than should be added

LIST OF TABLES

Table 3.5 Comparison between designed system and the existing system

Table 4.1 Simulation Data for Design-I

Table 4.2 Simulation Data for Design-II

Table 5.1 SOC Chart of lead acid battery

LIST OF ABBREVIATIONS

CARC- Control and Application Research Centre

PV- Photovoltaic

SOC- State of Charge

SBCS- Solar Battery Charging Station

BLDC- Brushless Direct Current

DOD- Depth of Discharge

RND – Research and Development

CHAPTER 1

Introduction

1.1 Introduction to Rickshaw- van

Non-motorized tri-wheeler rickshaws are the most common form of transport in Bangladesh. Once you get out of your home, there is always one or more number of such tri-wheelers grabbing your attention with a tinkling bell [1]. People here hardly need to walk due to significant facilities provided by the rickshaw or rickshaw-van. Most of the road spaces are narrow in rural areas and in cities too. Since most of the road trips are short with average distance of 3.8km, [2] rickshaws are preferred travel mode by women, children and the older people due to their safety, security and comfort- Taxi cab or CNG baby taxi can provide door to door service but the fare for such service is much more compared to rickshaw. Sometimes it becomes difficult for taxi cabs or CNG taxi to get in narrower roads as well. Normally a rickshaw can carry two or three passengers excluding the driver. Some of the rickshaw-vans, also known as “van-gari” are used for school going children and adults in cities as well as rural areas as a mode of transport [1]. Those rickshaw-vans have the capacity of carrying around six children or four people excluding the driver. These non-motorized tri wheeler uses human power to run. The driver applies muscular energy on the pedal to make it run and thus making it an extremely laborious task. The rickshaw and the rickshaw-van shown in Fig 1.1, Fig 1.2 and Fig 1.3 are traditional muscle driven tri-wheeler which is an extremely laborious task. A major group of people including upper middle and lower middle income group are benefited from the service provided by the rickshaw-vans as a mode of transport for being route-flexible.



Fig 1.1 Rickshaw in use today [3]



Fig 1.2 Rickshaw-van [4]



Fig 1.3 Rickshaw van for school going children [5]

1.2 Impact of Rickshaw Vans in the Economy of Bangladesh

It is observed that a significant number of workforce every year join in the labour market. The literate working force have the opportunity in industry sector such as garments or any type of official job but the illiterate working force does not have such opportunity and to earn for their daily bread they seek jobs in informal sectors such as rickshaw pulling or in constructions. Most of them choose rickshaw-van pulling as their profession because this profession ensures regular flow of income. At the same time, they have the options of choosing their own working hour and also route. Since most of the passengers are from upper middle to lower middle income group, we see transfer of money from such group to the poor. The estimation reveals that there are around 2 million rickshaw-van pullers in Bangladesh and 19.6 million are indirectly relying on this business, including repair-men, garage owners, manufactures and their families themselves[6]. A research revealed an astonishing fact that average income decreased by 15% for a job shift from rickshaw pulling to other profession [7]. The statistics has encouraged us to give more importance and technologically improve this sector for the development of the country.

1.3 Motivation

The slow-speed, muscle driven tri-wheeler is often blamed to be the cause of traffic jam and road accidents in Dhaka, where the city roads hardly have three lanes for cars. The vehicle uses muscular energy to drive and as a result immense physical strain is involved in this occupation. But the earning of the pullers compared to the physical strain involved is low [8,9] . As mentioned earlier, a huge number of people are relying on rickshaw or rickshaw-van pulling profession, it is necessary to improve technologically in order to advance the living standard. The motivation for working on this research and development program has been originated from the observation that a substantial modernization in this sector will not only improve the living standard of a huge number of people involved in rickshaw pulling, but also improve the quality of life of upper and lower-middle income group people. The electrically assisted rickshaw-van will relieve the pullers from extreme physical exhaustion by assisting them electrically using torque sensor, which will limit the over-use of battery bank. Solar panel will help in sharing the load power and solar battery charging station will be used to charge the batteries instead of using power from national grid. Thus, we are making efficient use of renewable resources and the making the system completely independent of national grid.

1.4 Overview of the Content

The following chapters portray the work that has been accomplished, the drawbacks and suggested future plans. The second chapter gives an overview of the whole system with existing features. The third chapter describes the chronological development of rickshaw from traditional rickshaw to electrically assisted rickshaw-van with PV support and torque sensor pedal. The fourth chapter specifies the torque sensor and PV array integration into the system with control algorithm. The torque adjuster designs and lab simulation data are mentioned. The fifth chapter gives an overview of the existing solar battery charging station that has been used to charge batteries and the data obtained from the SBCS are represented graphically. The sixth chapter specifies the design and concept of easy swapping techniques of the batteries from SBCS to rickshaw-van and vice versa in order to make the system much more user friendly. The seventh chapter is the most important chapter of our thesis where it represents the data obtained from field tests, data analysis and calculations of the energy saved from the battery.

CHAPTER 2

Overview of the Whole System

2.1 Introduction

The motorized rickshaw-van which is under research and development has been a full throttle controlled rickshaw-van, manufactured by Beevatech Limited. Beevatech Limited is the first professional electric auto rickshaw manufacturer in Bangladesh, established in 2001 as a group company of Prime Logistics Ltd [10]. The motorized rickshaw-van is made with light weighed modern steel body and a different architecture from the traditional rickshaw or vans. The rickshaw-van is capable of carrying greater number of passengers compared to the traditional rickshaw or van. Usually traditional rickshaw is capable of carrying 2 or 3 passengers and rickshaw-van is capable of carrying 4 or 5 passengers, whereas the motorized rickshaw-van is capable of carrying 6 to 8 passengers. As the government has disapproved commercialization of such motorized vehicle due to consumption of electricity from the already overloaded grid [11] , companies like Beevatech Limited has had to bear loss and are having difficulties in gaining approval again. A massive modernization of such electric tri-wheeler will improve the lifestyle of huge number of people involved in rickshaw pulling profession. Our motive is to find a solution to conserve power for such green electric rickshaw-van with the use of PV panel, torque sensor pedal and solar battery charging station. The motorized rickshaw-van has a brushless DC gear motor, four 12V 25Ah lead acid batteries connected in series, a controller unit, a throttle, main power key, emergency motor stopper, traditional front wheel brake and an extra rear wheel break, charge controller, charge indicator and other components. The details of all the components are mentioned in the following sections. Various views of the customized rickshaw-van used in our experiment are shown from Fig 2.1 to 2.4



Fig 2.1 Side-view



Fig 2.2 Front-view



Fig 2.3 Back-view



Fig 2.4 Top view

2.2 Components used

2.2.1 The Batteries

Four 12V, 25Ah rechargeable batteries has been connected in series that supplies 48 Volts to the BLDC motor. These are lead-acid batteries. Each battery is 16.5 X 17.5 X 12.6 cm in dimension. The batteries are placed under both the seats as shown in Fig 2.5. Each fully charged battery shows 12.7 volts across their terminals and 50.8 volts after connecting those in a series combination.

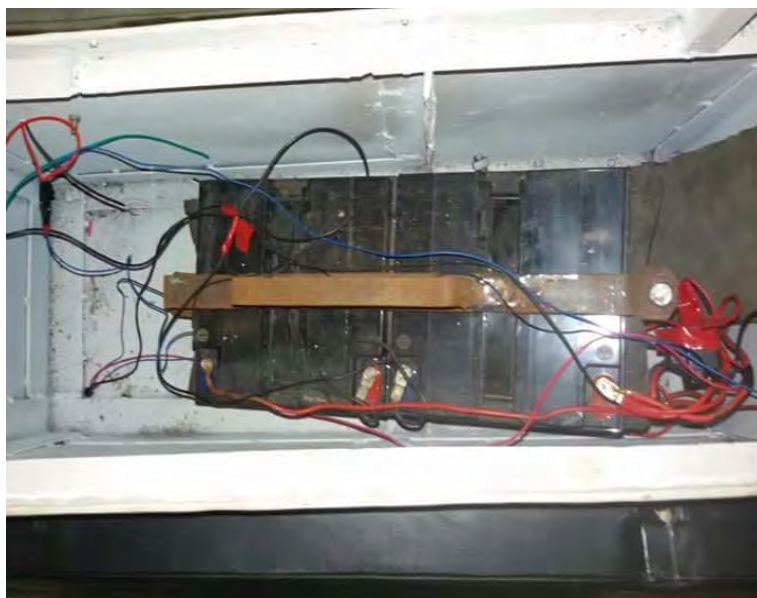

Fig 2.5 Two batteries

2.2.2 The Motor

A 500-550rpm rated brushless DC gear motor of 48V, 700W, 10-13.5A was used in the system which is attached with the main frame and is mounted under the seat as shown in Fig 2.6. The rotor of a brushless DC motor (BLDC) has permanent magnets and an electronically controlled rotating field stator, using sensors (rotary encoder or back-EMF) to detect rotor position. When at rest the brushless motors can produce a maximum torque which linearly decreases as velocity decreases. Because of their more torque per weight BLDC motors are most suitable for these kinds of vehicles. More torque per watt is highly beneficial for this vehicle as it has higher torque per watt (increased efficiency), increased reliability, reduced noise, longer lifetime (no brush and commutator erosion), elimination of ionizing sparks from the commutator, and overall reduction of electromagnetic interference (EMI).



Fig 2.6 BLDC motor

2.2.3 The Controller Box

The manufacturer integrated all the complicated electronics the brushless motor needs into a white box[12]. But due to the unavailability of proper resources, the controller wires were identified using some online resources, experiments, and exploring the connections in the system [12]. Fig 2.7 shows the controller box used in our experiment and Fig 2.8 shows identification of the controller cables

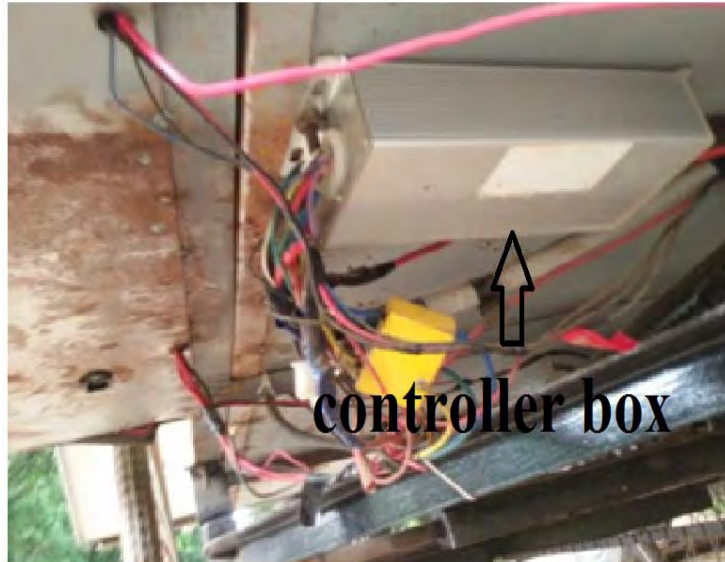

Fig 2.7 Controller box

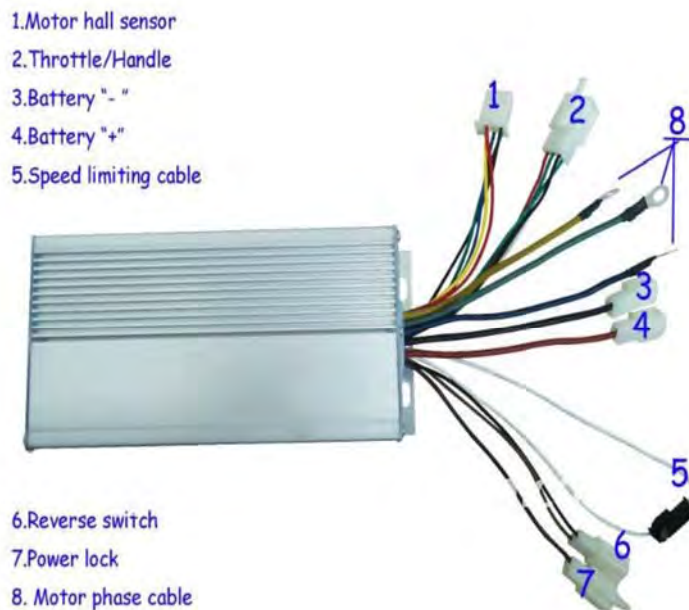

Fig 2.8 Identification of the controller cables [13]

2.2.4 The Throttle

The BLDC motor used throttle to control the speed of the motor. A throttle shown in Fig. 2.9 is a specially designed potentiometer. It has a biasing voltage of 5V which is provided by the motor controller unit. Its output voltage depends on the angle of the throttle. The output voltage is supplied to the controller. The speed of the motor depends on its output voltage. The motor speed

increases as the output voltage increases. The motor starts when the output voltage is 1.4 volts and when the output voltage is 3.5 volt the motor rotate at its maximum speed.



Fig 2.9 Throttle

2.2.5 The Power Key and Charge Indicator

A power key was used to turn the whole system 'on' or 'off' manually in the system. The rickshaw-pullers have to turn it on before they can use the throttle to drive the motor. It was a mechanism to 'short' two wires that go directly to the controller unit. Normally the wires are open switching 'off' the whole system. When it is keyed, the wires get 'shorted'.

The charge indicator shown in Fig 2.10 shows the SOC of the batteries from the moment it is connected across the 48V batteries. The charge indicator does not have a switch. There are three lead lights, when all the lights glow that indicates SOC of the battery is above 66%, when first light goes off it indicates SOC is below 66%, when second light goes off it indicates SOC is below 33%.

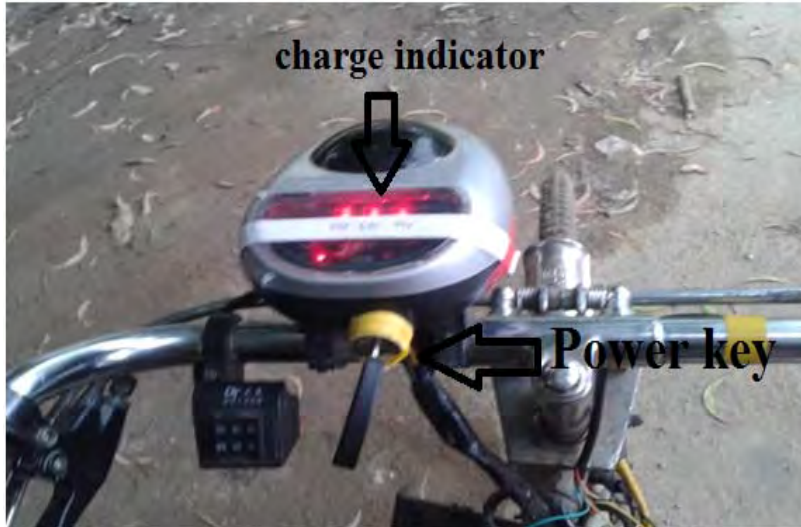

Fig 2.10 Power key and charge indicator

2.2.6 The Solar Panel

Solar panel in Fig 2.11 is placed at the top of the van on iron frame. Four 100W, 12V panels are connected in series that provides 48V to the batteries through the charge controller.



Fig 2.11 Solar panel

2.2.7 The Charge Controller

The charge controller in Fig 2.12 is used to ensure efficient charging of system battery and also supplying power to the load (which is the motor). While charging the battery the charge controller constantly check the current battery state and self-adjust accordingly to send only the right amount of charge to the battery. There are 4 terminals in the charge controller “PV+” , “PV-“, “48V+” and “48V-“.The “PV+” and “PV-“ terminals were to be connected with the positive and negative terminals of the 400-Watts Panel. The “48V+” and “48V-“ were to be connected across the 48V battery terminals.



Fig 2.12 Charge controller

2.2.8 The Torque Sensor

The torque sensor is a device used to measure and record the torque of a rotating system. It needs a biasing voltage of 5 volt from the DC source to operate. As the torque increases output voltage increases. The speed of the motor is directly proportional to the output voltage. Fig 2.13 shows the torque sensor pedal that has been installed in the rickshaw-van.

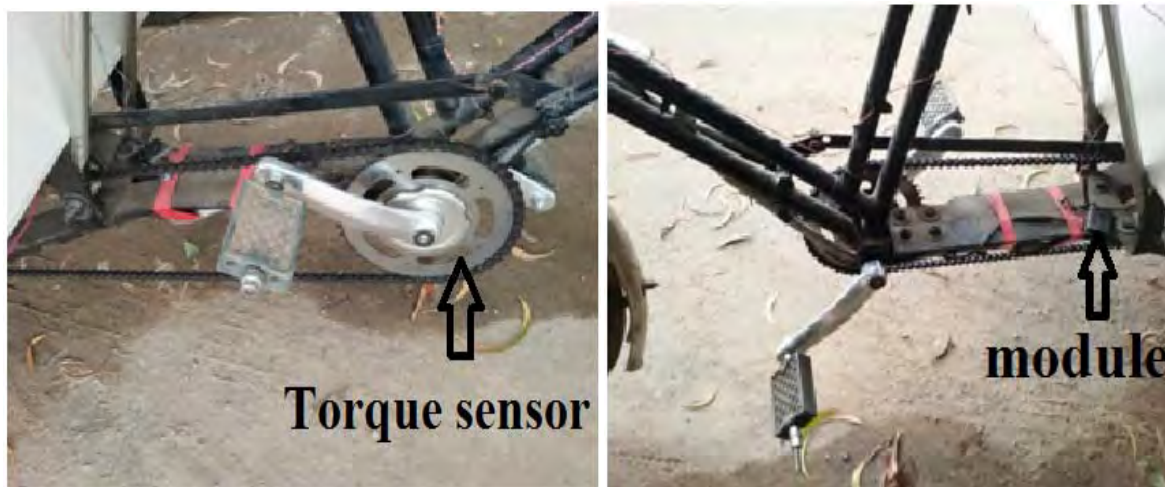

Fig 2.13 Torque sensor

2.2.9 The Brake System

Traditional hand clutch is used to stop the front wheels. Another hand-clutch is placed on the left hand-side shown in Fig 2.14 along the traditional hand-clutch. This hand-clutch is used to stop the motor at once. When the hand-clutch is released, it returns to its original position and it allows the motor to start again when needed. A rear wheel brake pedal shown in Fig 2.15 is

introduced in the system to stop the rear wheels. The rear wheel brake is a mechanical brake similar to cantilever brake that helps in stopping the moving central shaft or axle and thus stopping the rear wheels.



Fig 2.14 Hand-clutch



Fig. 2.15 Rear wheel brake



Fig 2.16 Traditional Hand-clutch

2.2.10 The Handle

The handle is placed inside the van as shown in fig 2.16. Handle supports the passengers from jerking.



Fig. 2.17Cabin handle

2.2.11 The Light system

Headlight is placed in front of the van, above the steering as shown in Fig 2.17. It helps the driver to see the obstacle at night while driving. Indicator, brake light and reflector are shown in Fig. 2.18. Indicator lights are used while taking turns. There are 6 indicator lights in the van, two at the back, two at the front, one at left side and one at right side. Fig. 2.20 shows that left indicator light is on. Brake light is used with rear wheel brake. When rear wheel brake is pressed, brake light is on as shown in Fig. 2.19. LED 12V, 6Watt light is placed inside the cabin as shown in fig. 2.21. Reflectors are placed at the back of the van. It glows when light falls on it.



Fig. 2.18 Headlight

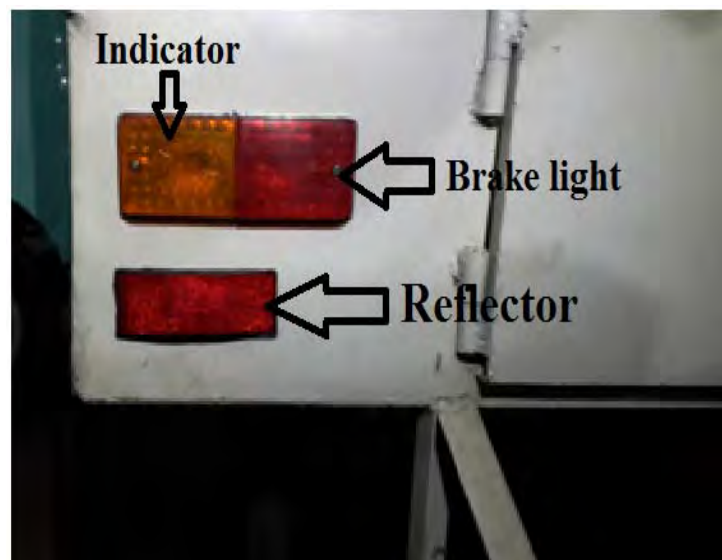

Fig. 2.19 Indicator, brake light and reflector



Fig. 2.20 Brake light is on



Fig. 2.21 Left indicator is on



Fig. 2.22 LED cabin light

2.3 Wiring of the Whole System

The components discussed above are all connected as shown in the wiring diagram attached in **APPENDIX A: Figure 1**.

2.4 Conclusion

Extra features such as handle, LED cabin light and reflector are added in order to make it much more user friendly. The most significant components here in this hybrid rickshaw are PV panel, charge controller and torque sensor pedal. A mechanism to reduce battery power consumption is developed with the use of torque sensor pedal and PV panel shares load power.

CHAPTER 3

Chronological Development of Rickshaw

3.1 Introduction

Many researches on electric improvement ideas have been implemented across the world to modernize the rickshaw which is the most popular fuel-free green transport. The main objective of modernization in this sector is to reduce the physical strain involved in this occupation and provide electric assistance to the puller. Modernization in this sector and researches has always encouraged many individuals since rickshaw is the most demanded mode of transport in Bangladesh. This chapter will describe the chronological development of the rickshaws from traditional rickshaw to electrically assisted rickshaw-van with PV support and torque sensor pedal. Five models, traditional rickshaw, electric rickshaw developed by Beevatech Limited [10], torque sensor based electric rickshaw [12], electric rickshaw with PV support [14] and electric rickshaw with both PV support and torque sensor, will be described in this chapter.

3.2 Traditional Rickshaw

The muscle driven tri-wheeler is very popular and most demanded mode of transport in Asia subcontinent, especially in Bangladesh. However this muscle driven rickshaw shown in Fig 3.1 causes enormous physical strains which makes the job extremely laborious. The income from this occupation is low compared to the physical stress involved in it. Due to its route flexibility and many other advantages, a significant number of people every year get involved in this occupation. Development in this sector for the sake of the rickshaw-puller and the users of rickshaw is always a concern.



Fig 3.1 Traditional rickshaw

3.3 Beevatech Model and Boraq Model of Electric Rickshaw

Beevatech Limited is the first professional electric auto rickshaw manufacturer in Bangladesh and was established in 2001 as a group company of Prime Logistics Ltd. The electric rickshaw eliminated the physical labour. It was made with a steel body which looks architecturally different than traditional rickshaw as shown in Fig 3.2. Four 12V, 20Ah lead acid batteries were used along with 48V, 500W brushless DC motor drive systems with throttle position sensor to control motor speed. The traditional chain wheel system was present but the rickshaw puller hardly used the pedal. However the throttle control mechanism consumes more electric power and it was seen that the battery gets discharged in 5 or 6 hours. All these batteries were charged from the national grid and thus consume more power from the overloaded grid. The system also reduces the battery life and motor due to frequent high current flow from battery to motor.



**Fig 3.2 Beevatech model
of electric rickshaw**

Boraq Limited is a smaller company compare to Beevatech Limited, but they converted old traditional rickshaw to electrically power assisted model. They made mechanical modifications in the traditional rickshaw to accommodate the batteries and motor. Boraq model of electric rickshaw used better and expensive lead acid batteries to increase the runtime. This increased the cost of the system and charging the batteries were still a concern.

3.4 Torque Sensor Based Electrically Assisted Rickshaw

CARC, BRAC University conducted research in 2012 in order to modernize the fuel free green rickshaw with torque sensor pedal integrated in Beevatech model of electric rickshaw [12]. A control system was designed with the help of torque sensor pedal that made the rickshaw pulling task much easier by assisting the human power with motor. Four 12V 20Ah lead acid batteries were used along with 48V, 500W brushless DC motor. The torque sensor was integrated in the system to reduce the over-use of the battery bank. This prevented frequent charging of the batteries and thus increased battery lifetime. It was seen that with torque sensor pedal, around 42% energy was saved. But at the end of the day, the battery got discharged and charging the batteries from the overloaded grid was still a concern.



Fig 3.3 Torque sensor based electric rickshaw

3.5 Electric Rickshaw with PV support

A research was conducted by CARC, BRAC University in 2013 to modernize and reduce the power consumption of electrically assisted rickshaw with PV support [14]. A 360W panel was placed on the roof of the Beevatech model of electric rickshaw. Four 12V, 20Ah lead acid battery along with 48V, 500W brushless DC motor was used. The research was conducted to find out the suitable panel state and it was found that future research and development program should be done in “flat panel state”. The ultimate result from the field test obtained was that around 50% can be saved with the use of PV panel in the electric rickshaw which would contribute to saving energy from the national grid as well as modernize the tri-wheeler. But the limitation of this model was the structure of the tri-wheeler. Due to the installation of 360Wp panel in flat state shown in Fig 3.4, the structure was heavy and the panel exceeded the maximum surface area of the rickshaw, making it unsafe in the road of Dhaka city.



Fig 3.4 Electric rickshaw with PV panel installed in “flat state”

3.6 Rickshaw-van with PV Support, Torque Sensor Pedal and Solar Battery Charging Station

CARC conducted a research on the use of torque sensor pedal used usually in some bicycles. Encouraged by the result obtained from the research with torque sensor pedal in the system and PV support in the system separately, CARC has developed battery operated rickshaw-van with PV support and torque sensor pedal. Solar battery charging station was implemented to charge the batteries and to make the whole system independent of national grid. The details of the components used in this green rickshaw-van are mentioned in chapter 2 and the ultimate results obtained from the field test are mentioned in chapter 7.



Fig 3.5 Rickshaw-van with torque sensor pedal and PV support

3.7 Conclusion

The chapter described the chronological development of rickshaw from traditional rickshaw to electrically assisted rickshaw-van with PV support, torque sensor and solar battery charging station. Chronological development of rickshaw is represented in a flow diagram attached in Appendix B Figure 2. At every stage of development the main objective was to reduce the physical stress and reduce power consumption from the battery and national grid.

CHAPTER 4

Integrating Torque Sensor and PV array into the System

4.1 Introduction

This chapter describes the overall features of torque sensor, its working principle and all aspects of integrating it into the system. This includes managing power source, mechanical fitting and testing the whole system's performance with it in lab conditions. The chapter describes the overall operation of the whole system with both torque sensor and PV array. The control algorithm of the system is mentioned in this chapter.

4.2 Introduction to the Torque Sensor

A torque sensor or torque transducer is a device for measuring and recording the torque on a rotating system, such as an engine, crankshaft, transmission, rotor, gearbox, a bicycle crank or cap torque tester [15]. It is a transducer that converts torque based mechanical input into an electrical output signal. There are two types of torque sensors, a reaction that measures static torque and rotary that measures dynamic torque [16]. Taking input from a DC voltage source, torque sensor generates output voltage corresponding to torque applied on specific crank or shaft. Within its operating region, the voltage output is linear with the applied torque.



Fig. 4.1 Complete set-view of torque sensor and other components [16]

4.3 Types of Torque Transducers and Torque Sensors [17]

- Brushless Rotary Torque Transducers
- Flange Torque Sensors

- Shaft Torque Sensors
- Multi-Axis Torque and Axial Force Transducers
- High Capacity Torque Transducers (>5000Nm)
- High Speed Rotary Torque Sensors (>55000rpm)
- Low Capacity Torque Transducers (<1N)
- Rotary Slip Ring Torque Sensors
- Miniature Torque Transducers
- Square Drive Torque Sensors
- Static / Reaction Torque Transducers
- Wireless Radio Telemetry Rotary Torque Transducers

4.4 Applications [17]

- Torque and Power Management on Drive Shafts
- Marine
- Steel Manufacturing
- Torque Wrench and Tool Testing/ Calibration
- Automotive and Motorsport
- Wind Turbine Development
- Aircraft Component Testing and Development
- Pump Development
- Production Process Monitoring

The torque sensor setup was purchased from Suzhou Victory Sincerity Technology Company Ltd (<http://www.jc-ebike.com>) which is located in Suzhou, China in order to use with the system. They undertake to develop, design and produce the components of e-bikes, mainly torque intelligent sensor system and relevant parts. The company has a group of experienced experts at designing and developing various e-bikes. The company has developed torque intelligent sensor system which conforms to the European standard --EN 15194, Japanese JIS standard [18]. Torque Sensor is their national patent product. To use with bicycles they have integrated the sensor technology inside the pedal-system. In the system, only the sensor and module were used.

4.5 Features of Torque Sensor [18]

- Brush/Brushless motor controllers are applicable for it
- The hardware may be installed like a normal chain wheel crank
- The electrical system is sensor/sensor-less motor type
- Main body parts are made of aluminium alloy
- Provides instant response while pressure is applied on pedal and pedalling is stopped or pressure on pedal is reduced

- Data collection per crank rotation from 18 to 96 times
- Magnet ring integrated with multi-pole improving greatly the precision of signal sampling
- The system is fully sealed against ingress of water and dirt



Fig. 4.2 Torque sensor and module

4.6 Technical Parameter Data [18]

- $V_{cc} = 5.15 \text{ V } (+/- 0.15\text{V})$
- Output, linear, zero-start, 0.5~4.5V
- Output torque >15N-m
- Delay time < 50ms

4.7 Electrical Connections

The electrical connection diagram for the entire setup was provided by the manufacturing company. This includes brushless-controller, torque adjustor, chain-wheels, module etc. But we will be using the torque sensor and the corresponding signal-producing module in the system.



Fig. 4.3 The torque-sensor pedal

The sensor was built in such a way that it could be fixed in any bicycle. However, assembling it in the tri-wheeler required a few mechanical modifications. The above figure shows the torque sensor pedal when implemented and installed to the rickshaw-van. This installation was done following the provided connection diagram provided by the manufacturing companies. This was ready for testing purpose.

In order to get input voltages from the controller connections, there are separate mechanisms. This has been shown in the diagram. But in the system, a different controller will be incorporated with the sensor. So, the independent operation connection diagram was extracted from the main diagram.

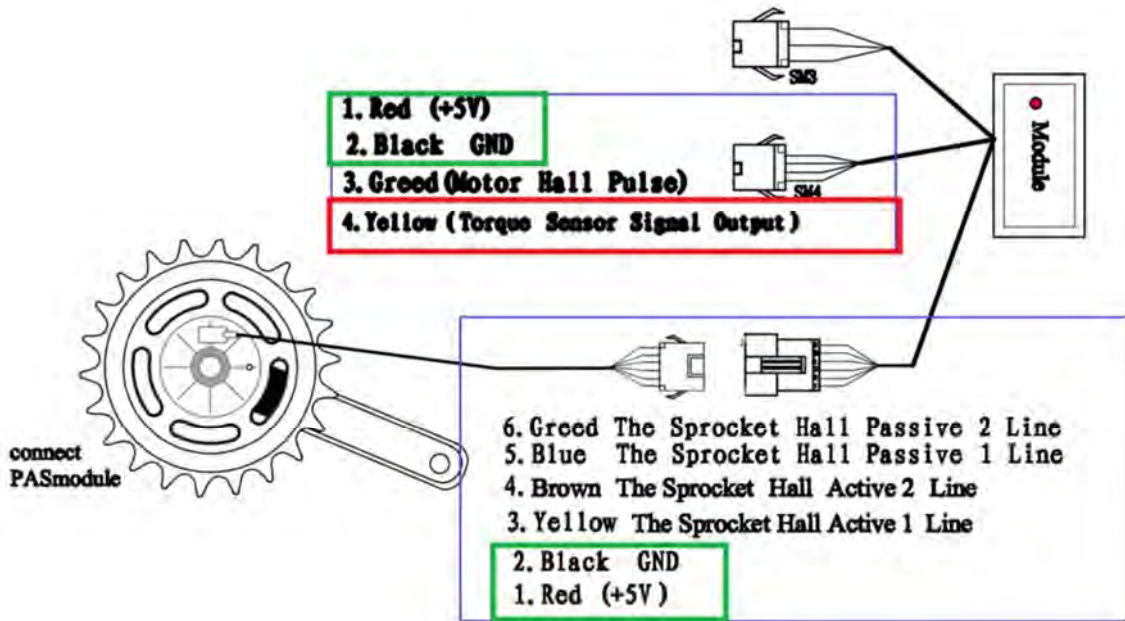

Fig. 4.4 Electrical connection diagram for independent operation of the sensor and module [18]

Figure 4.4 indicates that the Red and Black wires from SM6 (marked as +5V and GND) are the input biasing terminals for the sensor. For the module, the input voltages are marked in SM4. The Yellow wire from SM4 is the processed output from the torque sensor which will be used for motor control. According to applied torque in the pedal-crank of the sensor this wire gives the output voltage with respect to GND. So, this is the output which is supposed to be fed to the external control circuit.

4.8 Power Management

It is necessary to implement the whole system using a single power source from the main Rickshaw-van battery. A series of four 12V batteries have been used in the rickshaw-van. The external circuit design and the torque sensor specification setup require that only a +5V source is necessary to power all these devices. So, to serve the purpose LM7805 was used to get a fixed output of +5V. The power-source management used in the system is illustrated in figure 4.5.

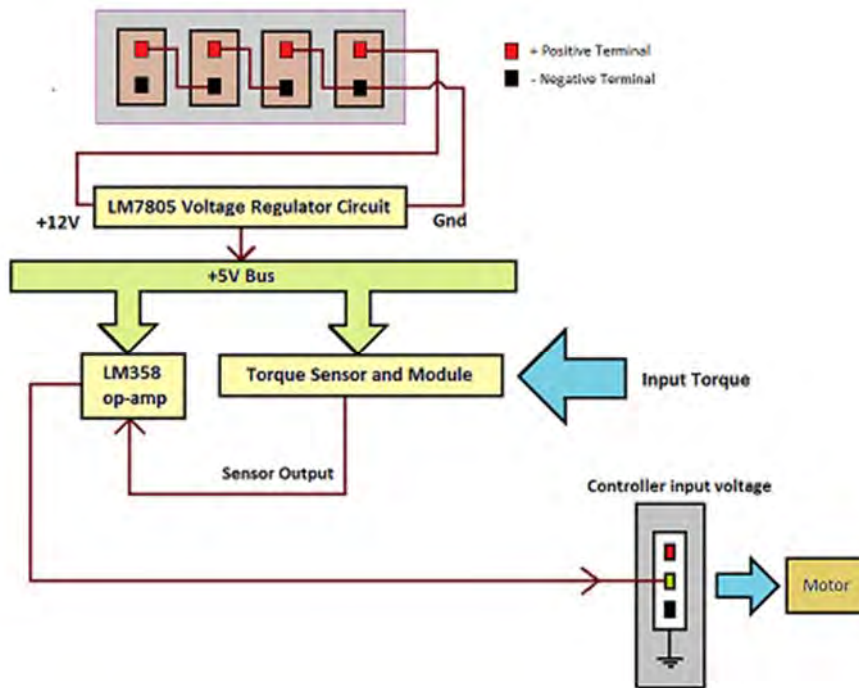

Fig. 4.5 Complete overview of the power management and signal flow

The above figure 4.5 illustrates the complete power management and signal flow of the system. Our system has four 12V batteries connected in series providing 48V. Only 12V is required as input to the voltage regulator circuit. The voltage regulator circuit will give +5V which will be fed to the amplifier circuit as biasing and also to power up torque signal producing module. When pressure is created on the pedal, there will be a certain torque for which the torque sensor and module will provide certain voltage to the amplifier circuit.

The torque adjuster will eventually output a voltage corresponding to the voltage provided by the sensor and module maintaining the ease while pedalling. This voltage is fed to the motor CU and eventually to the motor.

The hardware implementation of the complete system in PCB is illustrated in fig. 4.6.

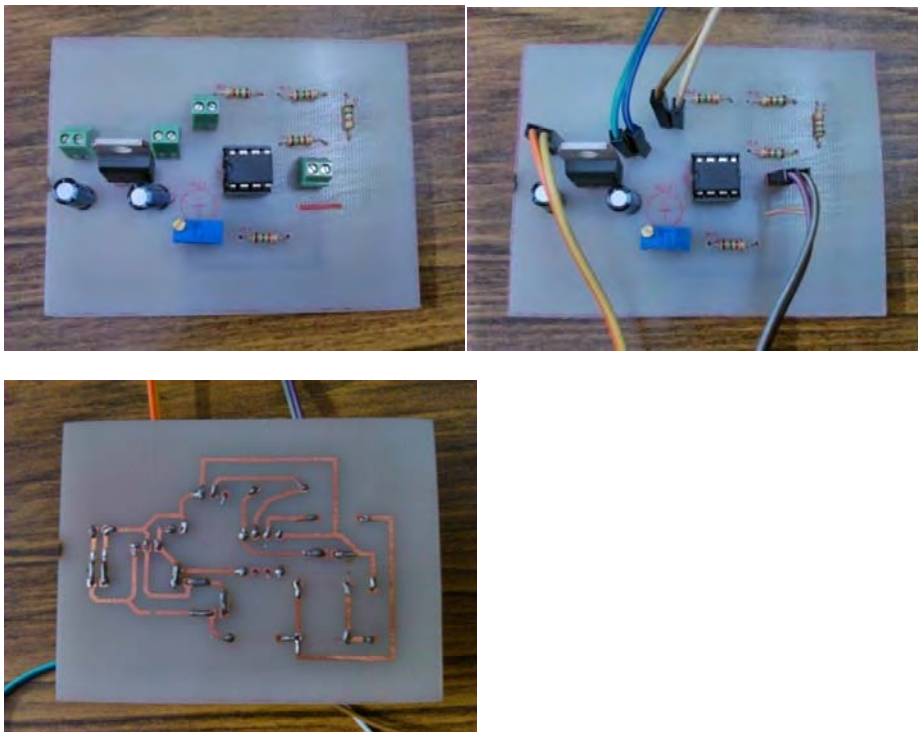

Fig. 4.6 Hardware implementation of the system in PCB

The torque adjuster was implemented in hardware. This way it will be a compact system and will eradicate problems arising due to the use of breadboard and a lot of wires connecting the components. While going for lab test and later on field test, the roads might not be smooth, so hardware implementation will resolve the problem as each of the components are soldered on the PCB board and there is no chance of any component to fall apart due to shakiness of the road.

4.9 Lab-Condition Testing of the Whole System

After the hardware implementation of the system in PCB board, the whole system was tested in lab condition. This time, the sensor was used in action and the system was run as it is supposed to ply on road. For testing the performance of it with the torque sensor, the wheels were connected and load was generated by generating friction on the wheels. The friction and load-dynamics from the road was kept in mind and imitated as approximate possible. For an approximate comfortable ease of the machine, a gain of 1.26 was set.

No external load was applied during the first few seconds. When the pedal was rotated in this condition, it was found out that the voltage was zero and the corresponding rpm in this region is due to the pedalling effort. Then a load friction was provided in the wheel and was increased with time. The motor started and pedalling seemed easier as the motor was assisting the pedalling effort. The threshold voltage, that is, the voltage at which the motor starts was found out to be 1.47 V. With a more increase in load, it was noticed that the maximum output voltage sustained at 3.6V as desired. Then the load was removed and the wheels were left to move freely. It was observed that pedalling became very comfortable.

In order to collect continuous data, a video camera was used to record corresponding data from multimeter and tachometer placed at proper positions. To note down the data, the video camera was replayed and paused with an approximate interval of a second.

4.10 Design-I

4.10.1. Introduction:

Limiting the use of the motor is the basic idea of this design. The basic concept used here is to limit the output of an op-amp by limiting its biasing voltage. It is known that the output of an op-amp is maximized to a value depending on the specific level of biasing voltage. LM358 operational amplifier is used in this design. It has a biasing voltage of +5V and its output is limited to 3.6V. This output will be directly fed in the CU terminals

4.10.2 The Circuit-Diagram and Explanation:

The external circuit diagram of the system is illustrated in Fig. 4.7. The key devices used here are LM7805 and LM358. LM7805 is a voltage regulator which gives an output of +5 V when a voltage more than 7.5 V is provided as input. The output is always fixed and it is +5 V.

The LM358 op-amp consists of two independent, high gains; internally frequency compensated operational amplifiers which were specifically designed to operate from a single power supply over a wide range of voltages. It is also possible to operate from split power

supplies and the low power supply current drain is independent of the magnitude of the power supply voltage.

The amplifier's maximum output is 3.6V when a voltage of +5V is supplied. This characteristic will help the system to maintain a maximum tolerable voltage input to the CU without interrupting the whole system by motor switching or sudden-stop-runs.

For instance, if gain is set to 2, an input of 1.5V will give 3V as output, but an input of 2.5V will give a fixed 3.6V instead of giving 5V as output. This advantage is utilized in the circuit diagram.

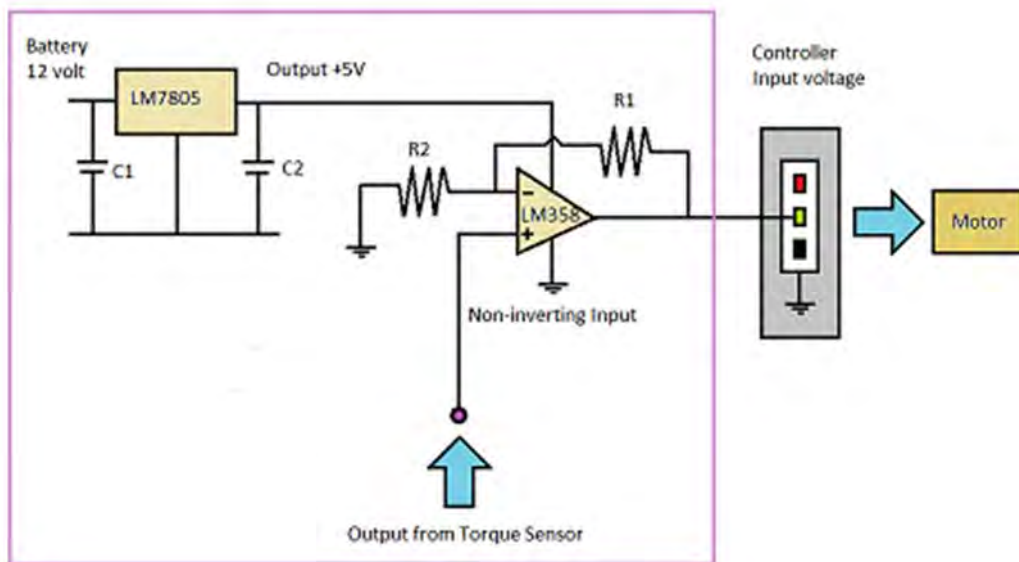

Fig. 4.7 Circuit Diagram for Design-I

4.10.3. Simulation and Results

For simulation in the lab, the biasing voltage was set to +5V. Voltage signals were provided following the pattern of 0 V to 5 V and again repeated from 5 V to 0 V. The output voltage was observed.

From the sensor simulation data it was observed that as input voltage increases, output voltage also increases. But after a certain value of input voltage, the output becomes fixed to 3.60 V. Again while decreasing the voltage, the output remains fixed at 3.60 V to that certain value of input voltage and then slowly decreases corresponding to the decreased value of input voltage. This satisfies the op-amp characteristics and limits the voltage fed to CU as a result limiting the use of the motor.

4.10.4. Sensor Simulation Data:

Input Voltage	Output Voltage	Input Voltage	Output Voltage
0	0	4.4	3.60
0.1	0.08	4.3	3.60
0.2	0.13	4.2	3.60
0.3	0.38	4.0	3.60
0.4	0.63	3.5	3.60
0.5	0.75	3.0	3.60
0.6	1.07	2.5	3.60
0.7	1.19	2.0	3.60
0.8	1.44	1.9	3.60
0.9	1.64	1.8	3.46
1.0	1.90	1.7	3.34
1.1	2.01	1.6	3.02
1.2	2.22	1.5	2.78
1.3	2.41	1.4	2.64
1.4	2.71	1.3	2.46
1.5	2.86	1.2	2.32
1.6	3.01	1.1	2.04
1.7	3.24	1.0	1.82
1.8	3.41	0.9	1.72
1.9	3.59	0.8	1.50
2.0	3.60	0.7	1.21
2.1	3.60	0.6	1.08
2.2	3.60	0.5	0.73
2.5	3.60	0.4	0.58
3.0	3.60	0.3	0.47
3.5	3.60	0.2	0.16
4.0	3.60	0.1	0.08
4.5	3.60	0	0

Table 4.1: Simulation Data for Design-I

4.11 Design-II

4.11.1. Introduction

The basic concept used in this design is the use of a voltage divider circuit. Instead of directly feeding the voltage coming from the torque sensor and module to op-amp, the input signal passes through a voltage divider to reduce the incoming voltage to 0.6 of the input voltage. This reduced voltage is then fed to the op-amp. This way even if the incoming voltage is higher, it will be reduced to certain value and eventually limit the use of motor.

4.11.2 The Circuit-Diagram and Explanation

While practically running the vehicle, it was seen that when puller uses torque sensor pedal, that is pressure is created on the pedal, the voltage generated is much higher around 3-4 V. So to minimize this voltage, a voltage divider is used in such a way that the output voltage becomes 0.6 of the input voltage. That is, $V_{out} = 0.6 * V_{in}$

The modified circuit diagram is shown in figure 4.8. Here a voltage regulator circuit has been used in order to limit the torque sensor input voltage.

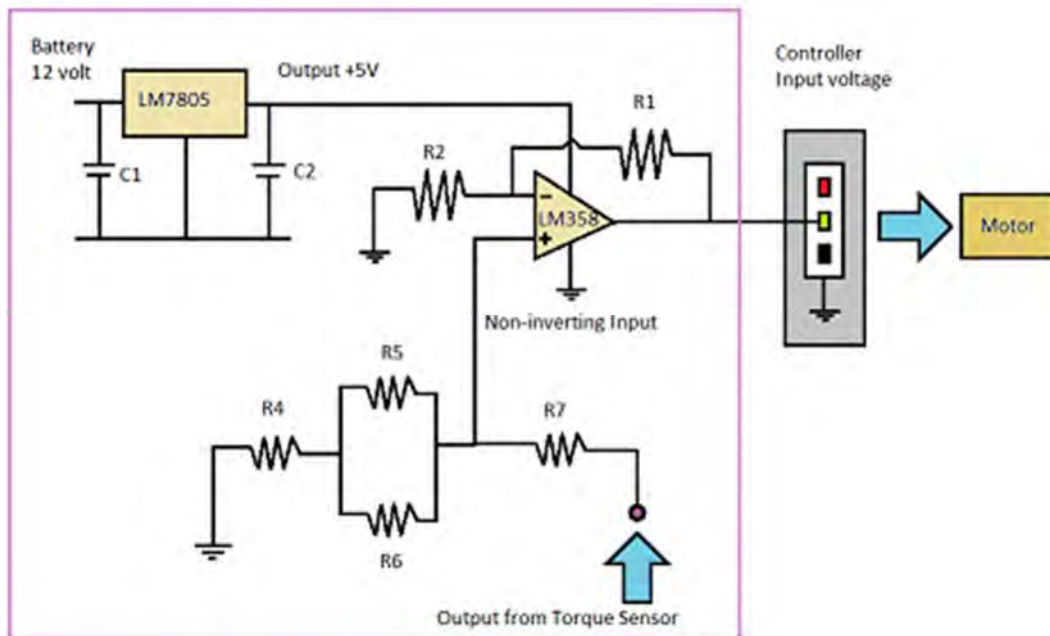

Fig. 4.8 Circuit diagram of the system for design-II

4.11.3. Sensor Simulation Data:

Input Voltage	Output Voltage	Input Voltage	Output Voltage
0	0	4.5	3.58
0.1	0.01	4.4	3.51
0.2	0.12	4.3	3.38
0.3	0.17	4.2	3.35
0.4	0.25	4.1	3.23
0.5	0.32	4.0	3.20
0.6	0.39	3.9	3.16
0.7	0.51	3.8	3.12
0.8	0.58	3.7	2.93
0.9	0.62	3.6	2.81
1.0	0.70	3.5	2.75
1.1	0.76	3.4	2.70
1.2	0.83	3.3	2.59
1.3	0.88	3.2	2.55
1.4	1.05	3.1	2.44
1.5	1.12	3.0	2.40
1.6	1.17	2.9	2.27
1.7	1.22	2.8	2.18
1.8	1.31	2.7	2.09
1.9	1.45	2.6	2.02
2.0	1.49	2.5	1.95
2.1	1.60	2.4	1.90
2.2	1.64	2.3	1.79
2.3	1.72	2.2	1.70
2.4	1.84	2.1	1.64
2.5	1.93	2.0	1.57
2.6	1.98	1.9	1.52
2.7	2.06	1.8	1.36
2.8	2.12	1.7	1.33
2.9	2.25	1.6	1.25
3.0	2.30	1.5	1.14
3.1	2.43	1.4	1.08
3.2	2.50	1.3	0.98
3.3	2.59	1.2	0.87

3.4	2.61		1.1	0.79
3.5	2.70		1.0	0.70
3.6	2.82		0.9	0.62
3.7	2.90		0.8	0.59
3.8	2.95		0.7	0.46
3.9	3.04		0.6	0.39
4.0	3.12		0.5	0.32
4.1	3.26		0.4	0.26
4.2	3.28		0.3	0.16
4.3	3.41		0.2	0.05
4.4	3.50		0.1	0.03

Table 4.2 Simulation data for design-II

4. 12 Comments

Some important benefits are added due to the circuit design. These are as follows:

- As the maximum output for op-amp is limited by limiting the biasing voltage that is motor's use has been limited, so the external circuit becomes independent of hand-clutch or power-keys.
- The circuit consists of only two IC, LM358 and LM7805 thus reduces complicity.
- For LM358 there's no requirement for negative biasing.
- It is easy to power torque sensor and all other devices from vehicle battery and bias the devices using single 5V supply using LM7805.
- The ride will be comfortable as no sudden thrust takes place.
- Incase of high input voltage coming from the torque sensor and module, it is first reduced to 0.6 of the input voltage and then fed to the operational amplifier. This way motor use can be limited.
- When required consistent high assistance can be achieved. For instance, while going uphill, it might be fatal if motor stops when maximum torque level is crossed. But this problem is eradicated and motor will keep on assisting with its maximum power corresponding to 3.6V.

The Design-II circuit using voltage divider has been used finally chosen for field tests. This way the torque adjuster has been integrated and simulated as a single circuit. The whole external circuit is powered up using 12V from the main vehicle battery and +5V that is required to power the torque sensor and module is obtained from the IC LM7805. Thus no other external power supply is required.

4.13 Integrating both Torque Sensor and PV Array in the System

A 400Wp panel is installed on the roof of the rickshaw-van that provides a share of the required electrical load alongside the battery bank to reduce the energy consumption from the battery bank. Four 100Wp panels are connected in series. The 400Wp PV array installed on the roof of the van is shown in Fig 4.9 and the specifications of the 100Wp PV array is mentioned below in section 4.14.1. The operation diagram of the whole system with both PV panel and torque sensor is shown in Fig 4.10

4.13.1 Specification of PV Array

- Maximum power output (5%) - 100w
- Open circuit voltage - 21.6v
- Short circuit current - 6.46amp
- Voltage at MPP – 17.2v
- Current at MPP – 5.8amp
- Nominal operating voltage – 12v
- Max system voltage – 600DC
- Cell type - Mono-Crystalline
- Dimension – 51cm*118cm
(+/-3%) at STC ; Irad-1000w/m² ; AM=1.5 ; Cell temperature = 25



Fig. 4.9 Solar panel on rickshaw -van

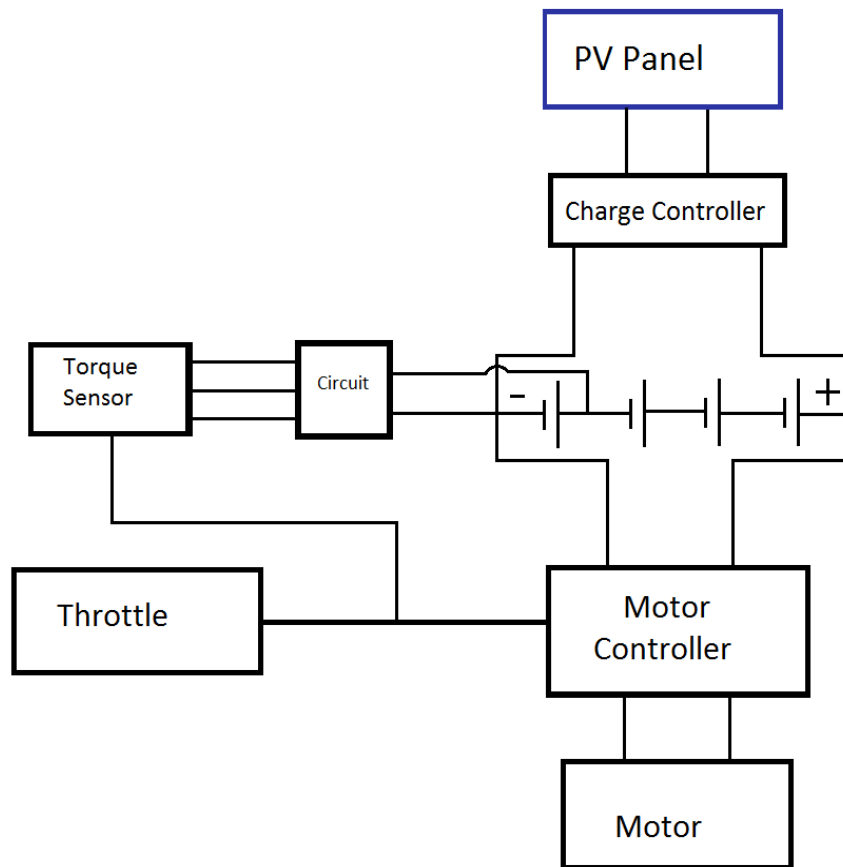

Fig 4.10 Block diagram of the whole operation

4.14 Control Algorithm

A signal from torque sensor or throttle controls the speed of the BLDC motor. When there is no signal from the torque sensor or throttle, the rickshaw is at stationary. The PV array is generating power but rickshaw is at stationary, the total generating power will be used to charge the battery only.

Fig 4.11 shows the flowchart of the whole system. When there is signal from the torque sensor or throttle three conditions may occur.

1. The PV array cannot generate any power due to solar irradiation, in this case battery supply the load motor solely.

- The PV array generates more power than required by the load, in such situation, excess power is used to charge the battery.
- The PV array is generating power but not adequate enough to run the load, in this situation load power is shared by the PV array and the battery bank.

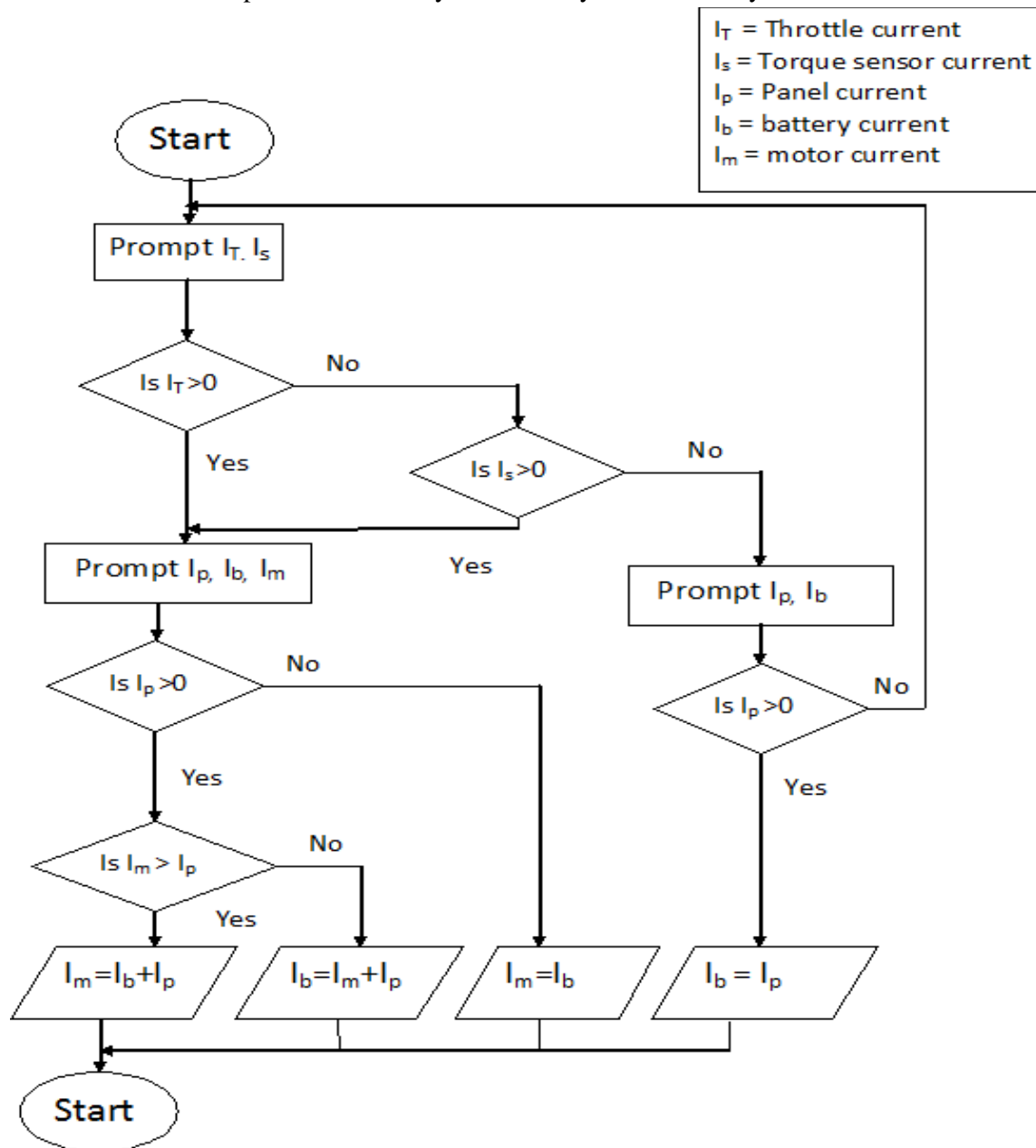

Fig 4.11 Flowchart of the whole system

4.15 Conclusion

From the data collected in lab condition it can be concluded that the behaviour of the whole system was satisfactory. During the few hours of experimentation and testing, no unexpected performance took place. So, the system was ready for field test and practical observation. The Design-II circuit using voltage divider has been used finally chosen for field tests. This way the torque adjuster has been integrated and simulated as a single circuit. The whole external circuit is powered up using 12V from the main vehicle battery and +5V that is required to power the torque sensor and module is obtained from the IC LM7805. Thus no other external power supply is required. Both PV array and torque sensor was integrated into the system and operated as shown in the operational diagram and control algorithm flowchart.

CHAPTER 5

Overview of the Solar Battery Charging Station

5.1 Introduction to the Solar Battery Charging Station

A solar battery charging station has been implemented on the rooftop of BRAC University building 2 to determine its feasibility, performance and applicability. The reason behind implementing the solar battery charging station was to charge the batteries instead of charging from the national grid. Although PV array and torque sensor combined together contributes to saving energy, at the end of the day, the battery still needs to get charged from the national grid. So in order to make it completely independent of the national grid and harness the solar energy, solar battery charging station (SBCS) is implemented on the rooftop of BRAC and make efficient use of it, solar battery charging station is implemented.



Fig 5.1 SBCS on the rooftop of BRAC university building 2

At least two sets of batteries should be allocated for each vehicle so that if one set of battery is discharged down to 50% SOC, then that set of battery will be handed over to the solar battery charging station to set for charge and be ready for service again and another set of 100% full charged battery will be there to replace the old sets of battery which is to be

discharged down to 50% SOC. The whole concept of the solar charging station is represented in the figure 5.2

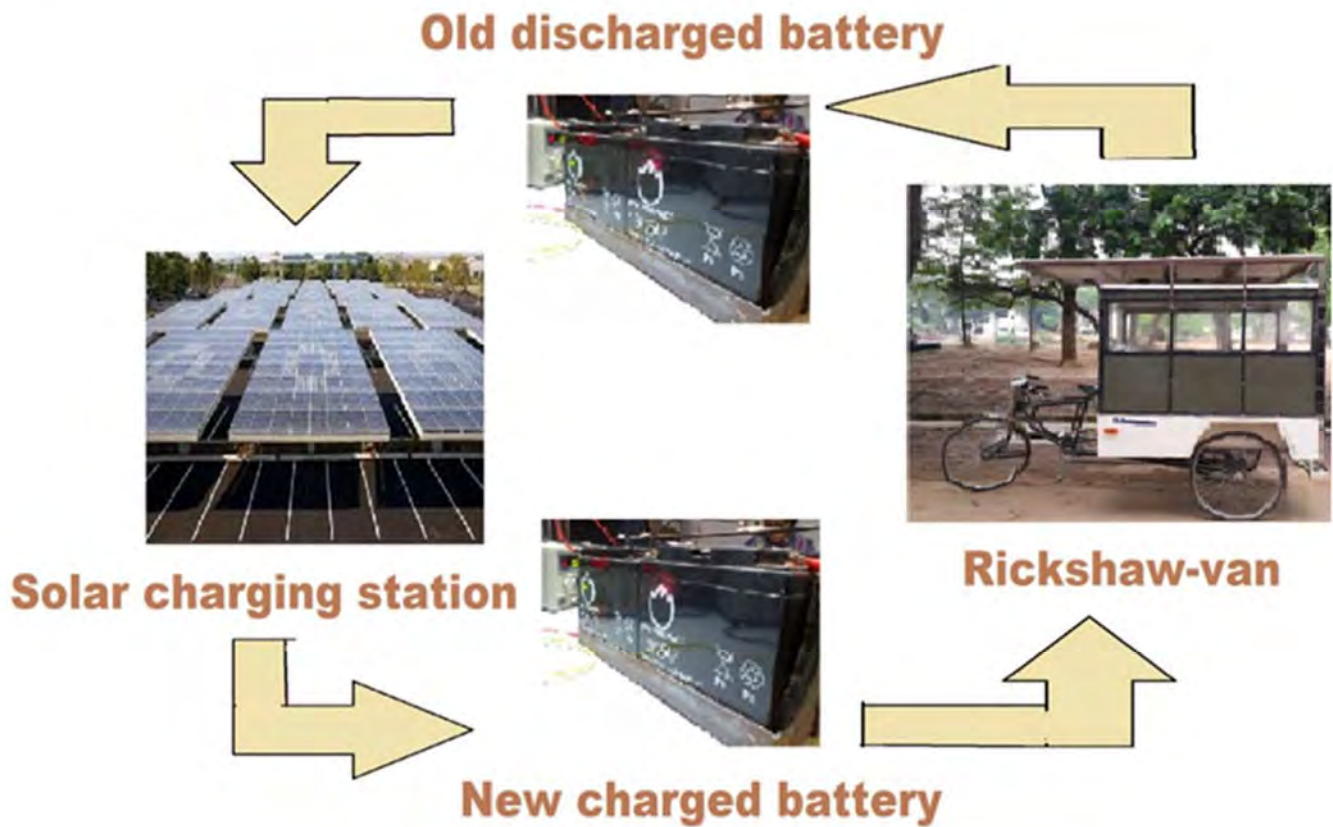

Fig 5.2 Solar battery charging station concept

5.2 Operation of Solar Battery Charging Station

The existing system has 400Wp PV array installed on the solar battery charging station where two panels are installed, 200Wp each. Two 200Wp PV modules are connected in series to provides power to a 68V DC bus. From there it is divided and fed in two sets of batteries using two charge controllers. The specifications of the modules are mentioned below. The operation diagram of the solar battery charging station is given below.

- Maximum Power: 200 Wp
- Nominal voltage: 34.92V
- Nominal current: 5.70A
- Open circuit voltage: 44.64V
- Short circuit current: 6.2A
- Number of cells: 72

- Weight: 14.5kg
- Dimensions: 1580*808(MM*MM)
- Max system voltage: 600DC
- Power tolerance: +-3%

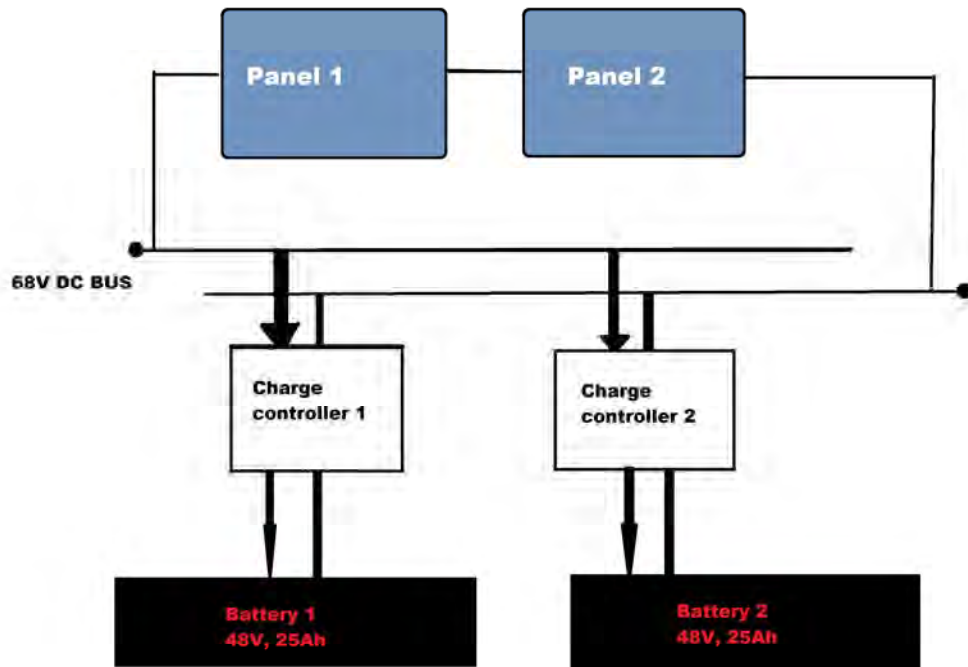

Fig 5.3 Functional block diagram of SBCS

5.3 SOC of the Battery

State of charge (SOC) is the equivalent of a fuel gauge for the battery pack in a battery electric vehicle (BEV), hybrid vehicle (HV), or plug-in hybrid electric vehicle (PHEV). The units of SOC are percentage points (0% = empty; 100% = full). An alternate form of the same measure is the **depth of discharge (DOD)**, the inverse of SOC (100% = empty; 0% = full). SOC is normally used when discussing the current state of a battery in use, while DOD is most often seen when discussing the lifetime of the battery after repeated use [19]. The SOC of the battery has been determined from online source. Measuring SOC is not accurate always and so SOC chart obtained from online source was used as a guideline. We have noted the battery voltage when the current has become approximately zero while battery charging. A fully charged battery 12V battery has 12.73V across its terminal and 50% discharged battery showed 12.1V across its terminal. The SOC chart is given in the table below in Table 5.1.

Charge (SOC)	12V Battery	48V Battery
100%	12.73	50.92
90%	12.62	50.48
80%	12.50	50
70%	12.37	49.48
60%	12.24	48.96
50%	12.10	48.40
40%	11.96	47.84
30%	11.81	47.24
20%	11.66	46.64
10%	11.50	46.04

Table 5.1 SOC chart of lead acid battery [20]

5.4 Data obtained from Solar Battery Charging Station

The 50% discharged batteries were brought to the solar battery charging station to charge the batteries. The batteries were charged during peak solar hours from 11am to 5pm. It was observed that it takes approximately 6 to 8 hours to charge a set of 48V 25Ah battery fully. The test was conducted from 11am to either 5pm or till the supply current was significantly lower (less than 1A). The data were obtained at hourly interval and used to compile the following graphs. Fig 5.4 is the graphical representation of the panel supply profile in SBCS and Fig 5.4 represents the voltage across the terminals of four 12V batteries connected in series vs. time.

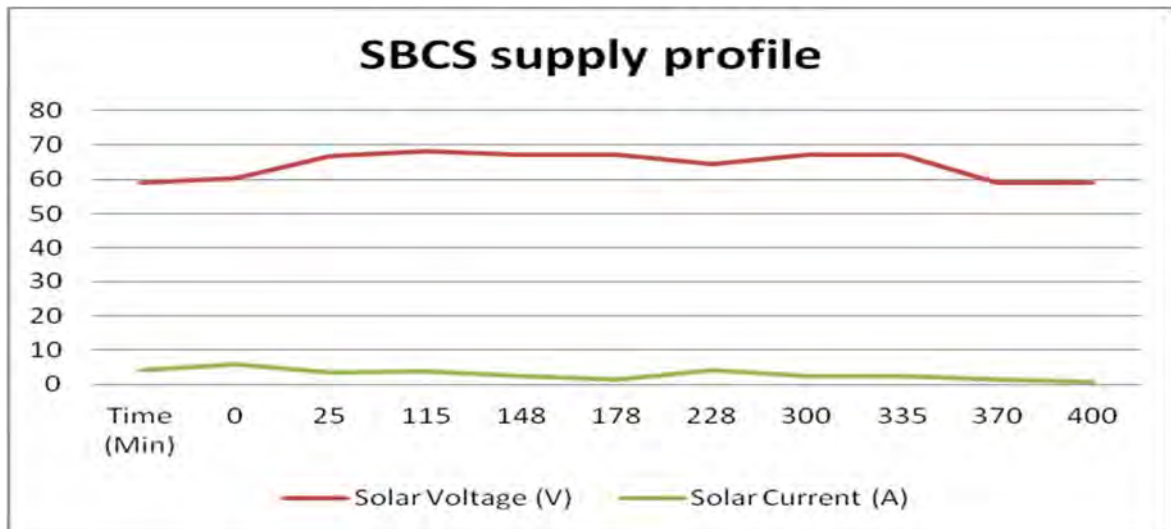

Fig 5.4 SBCS supply profile

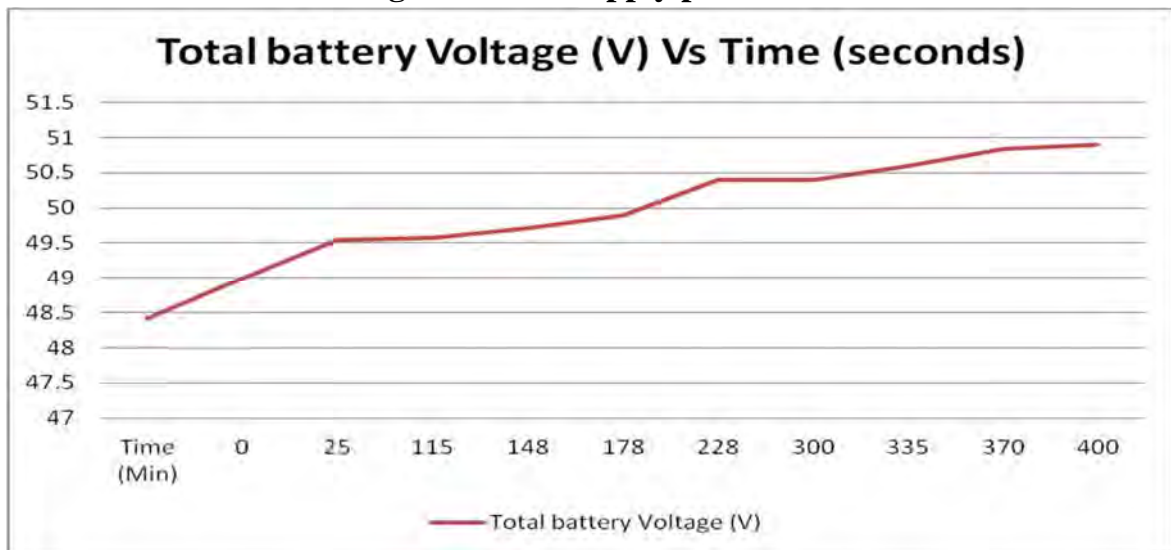

Fig 5.5 Total battery voltage (volts) vs time (seconds)

5.5 Conclusion

The whole concept and purpose of building solar battery charging station is mentioned in this chapter. From the data obtained, we can conclude that within 6 to 8 hours, four 12V 25Ah batteries gets fully charged provided that the average panel supply current is around 3A. A significant amount of energy will be saved with the commercialization of such type of charging station in future and thus save energy from the national grid.

CHAPTER 6

Easy Swapping of Batteries from Tri-Wheeler to Solar Charging Station and vice-versa

6.1 Introduction

Lead-Acid batteries are quite heavy and strenuous to sustain a long distance at a stretch. In our solar van, four of such Lead-Acid batteries have been used each weighting 7.1 kg and 181 X 77 X 171 mm in dimension. Due to their heavy weight it becomes very hard for a person to carry all four batteries at a time and take it to the charging station and also bring new sets of batteries from the charging station to replace the old ones on the van. To ease the task an effective battery swapping system has been developed.

6.2 Current Swapping System

In the current design of the Tri-Wheeler there is only one small gate at the rear side of the vehicle. When the charge of the batteries goes down, they need to be replaced by new sets of charged batteries. For charging batteries there is a solar charging station from where new batteries need to be swapped by the old ones.

Our solar van design is such that the batteries are placed under the passenger seats on both sides. So, one has to get inside the van, remove the seats, take out those batteries from the tri-wheeler and carry it to the charging station for charging purpose. At the same time, charged set of batteries has to be taken from the charging station, carry them to the van and place them inside the groove under the passengers' seats.

The batteries are quite heavy and so it becomes difficult to uphold a long distance. Taking them out of the van, carrying them to the solar charging station and again bringing new set of charged ones to the van kills a lot of energy and time as well and much strength is required for whole swapping purpose.



Fig.6.1 Side and rear view of solar tri-wheeler

6.3 Limitations of Conventional Swapping System

To carry the batteries certain trolleys are available. These trolleys are used to transfer different heavy loads from one place to other. Such trolleys are of fixed structure and the platform is not adjustable, i.e. it is kept fixed at a certain height.

There is a base support platform to place the batteries and other loads, underneath of which there are 4 wheels attached and a long handle attached to the base support to assist moving the trolley from place to place. The height of the platform of the trolley is very low compared to the conventional height of the vehicle at which the battery is placed on the battery groove. It can uphold heavy loads, but the rigid structure of such trolleys poses some drawbacks.



Fig.6.2 Conventional trolley used to transport load

The drawbacks of the conventional trolley design used for carrying batteries and other loads:

- The base support platform is fixed
- Not possible to adjust with the height of the vehicle
- Much strength is required to pull out batteries and place on the platform
- No automatic system
- Everything is done manually
- Not suitable for people to handle

So, the conventional design of the trolley has quite a number of drawbacks considering its fixed structure. This limits the facilities for adjusting with the height of the vehicle as different vehicles might be of different heights. This causes difficulty for older people as well. Since the batteries are heavy it is hard task for an aged one to take out and place on the trolley single handed. Everything has to be done manually using much strength.

6.4 Proposed Design-I:

6.4.1 Introduction

An easy and effective battery swapping system has been developed which will diminish most of the flaws of the conventional swapping system and trolleys.

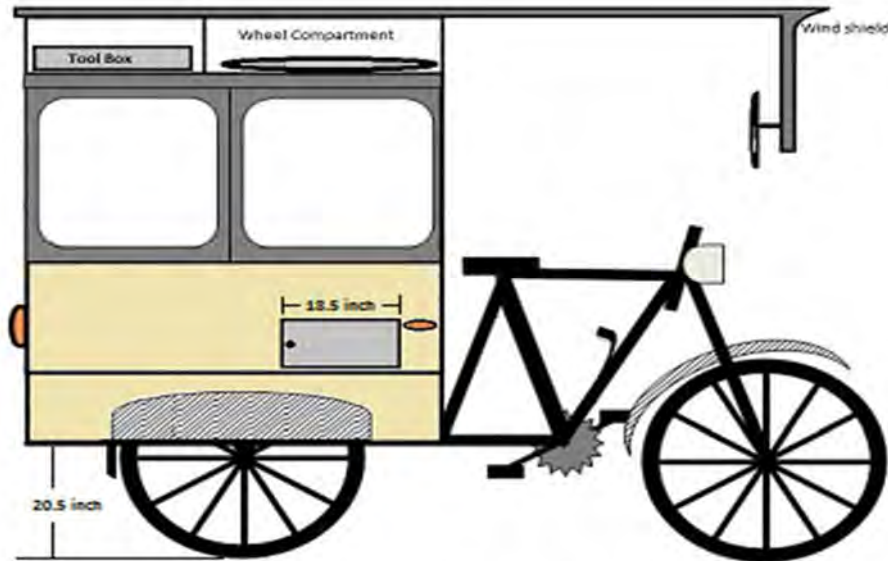

Fig.6.3 Solar tri-wheeler

The proposed new design includes a small door on both sides of the solar van just beside the battery groove. These side doors can be opened and closed from outside the vehicle. This will solve the problem of getting inside the van every time the batteries need to be taken out or put inside. It will eventually save time as well. In order to consider safety issues of the battery, there should be certain lock to keep the batteries secure from getting stolen.

6.4.2 Roller System underneath the Batteries

Inside the van and underneath the batteries a roller system is set just like the roller in treadmills. The rollers will have a handle attached to it which will be used to roll it both clockwise and anti-clockwise. When batteries get discharged they will need to be replaced by charged ones in order to keep the van going. With the help of the handle attached to the roller on both sides, batteries can be easily taken out without holding them and pulling them out

and putting them back inside using much strength. This will require comparatively less energy to do the job.

While taking out the old batteries from the van, the roller is rolled in clockwise direction. On the other hand, while placing new batteries inside, the roller is rolled in anti-clockwise direction using the handle. This mechanism is similar to a 'pulley system' where heavy loads can be pulled up and down using less strength and labour.

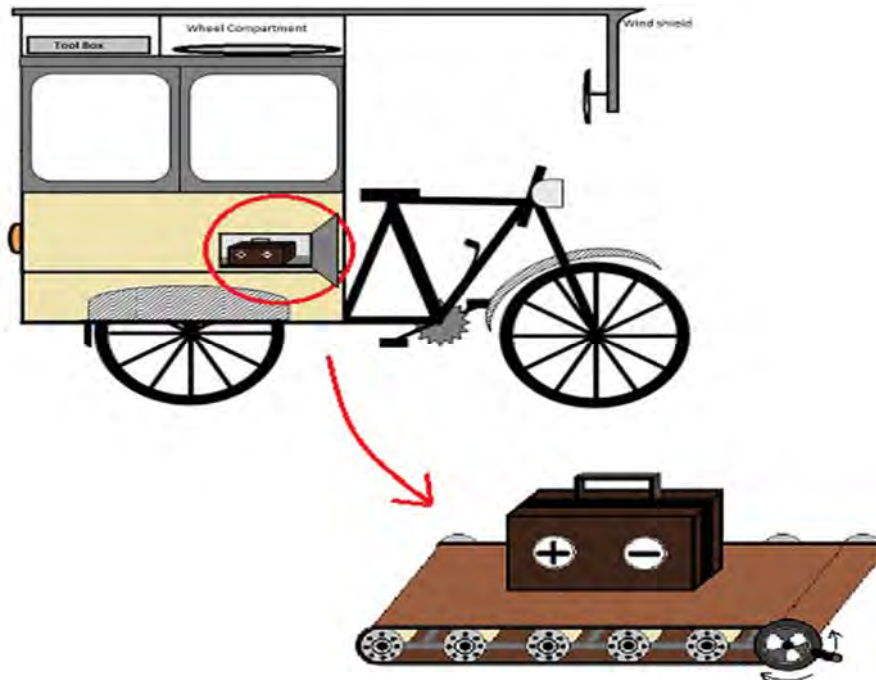

Fig.6.4 Roller system used to swap batteries

6.4.3 Adjustable Trolley

The conventional trolley is a fixed structure whose base platform cannot be adjusted in accordance to the height of different vehicles. Due to this structure of the trolley certain difficulties are faced while swapping batteries.

Our proposed new structure of the trolley is such that the length will be in accordance to the height of the vehicle. This will ease swapping and will not need much muscle power to move the batteries.

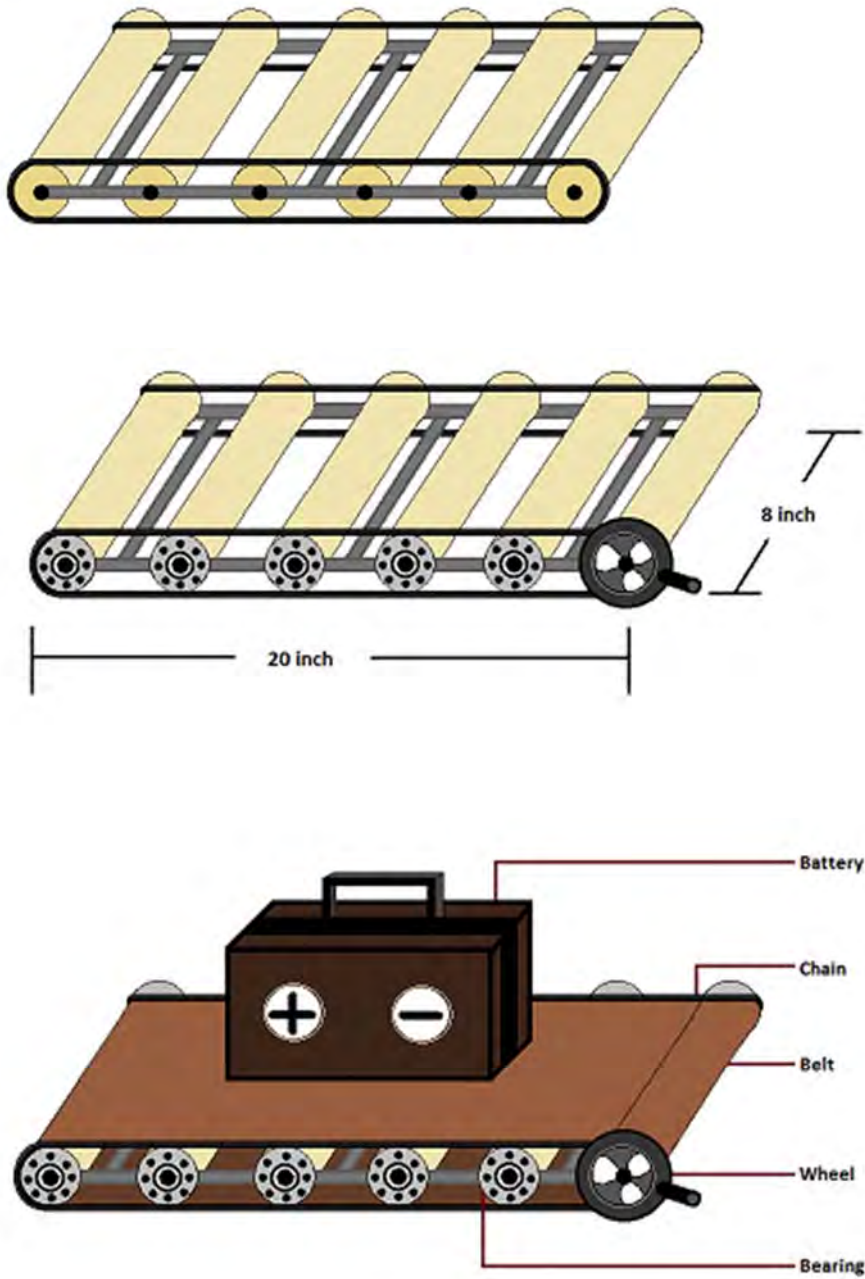

Fig.6.5 The skeleton of the roller system

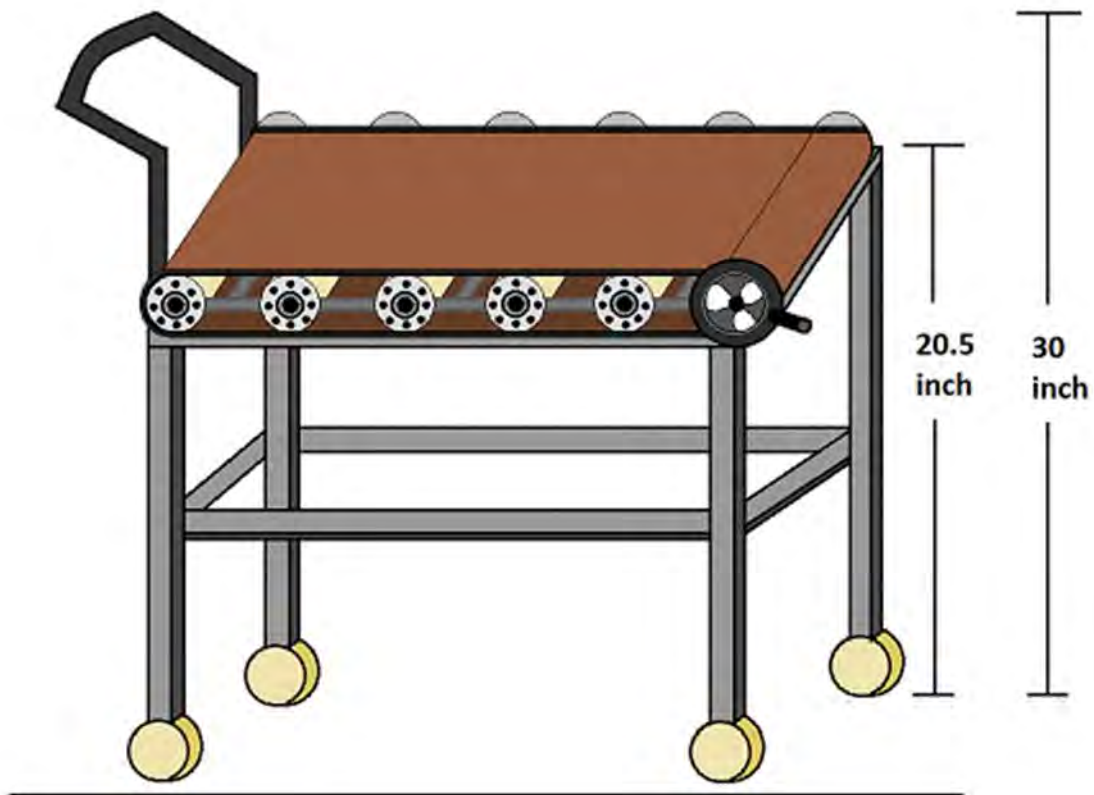

Fig.6.6 The proposed new design of the trolley

The structure of the trolley should be more like the one shown above. The roller system has a wheel attached to it which can rotate in both clockwise and anticlockwise direction. There are bearings so that it can rotate along the trolley table and above which chains are attached along the whole structure. A strong belt is then placed over the chains. On this belt batteries are to be placed. The four legs of the trolley should be connected to each other through metallic rods. This way the whole structure will be strong enough to bear the loads as well as the rollers attached to them.

6.4.4 Mechanism

The new proposed design of the trolley is made maintaining the height same as that of the vehicle where the batteries are place inside. A roller system is attached on top of the table which has wheels at the bottom so that it can be easily movable.

The old discharged batteries inside the van need to be replaced by the new ones which remain in the charging station. In order to replace the old ones, the trolley needs to be taken to the

van. When the trolley reaches the van, the small door on the side of the van is opened; the edge of the trolley is merged with the van where discharged batteries are kept maintaining the exact height. The wheels at the bottom of the trolley are locked so that it won't fall back due to the heavy weight of the batteries. Next the roller on the van is rolled clockwise with the help of the handle so that battery slides smoothly to the platform of the trolley and immediately the roller on the platform of the trolley is also rolled in clockwise direction to safely keep the old batteries towards the middle of the platform.

After this, the old batteries are taken to the charging station keeping them placed on the trolley. They are replaced by the new ones and taken again to the van. Like the process mentioned earlier, the trolley is merged with the van along the same height of the battery groove and door, wheels at the bottom of the trolley are locked. Next the wheel on the roller is rotated anti-clockwise direction so that the battery slowly moves and is placed inside the groove of the vehicle. The wheel attached to the roller inside the vehicle is rotated anti-clockwise to safely keep the battery toward the middle of this structure. After this the door on the side of the vehicle is closed and locked to keep the batteries safe.

6.4.5 Advantage of proposed Design-I

- Length is made according to the length of the vehicle
- No need for bending down to take out and place batteries on the trolley
- Requires less manual labour
- Roller system assists in moving the battery with less physical power
- Wheels are both way rotator

6.5 Proposed Design-II:

6.5.1 Introduction

The proposed Design-II for battery swapping purpose includes a trolley having height adjusted to the height of the battery groove inside the vehicle and an actuator attached to the handle of the trolley. The actuator is a 12V DC one and can be easily powered by the 12V batteries. The batteries will be placed on a tray on the trolley table. With the help of the actuator, the tray can be easily slide along the table.



Fig.6.7 12 volt Actuator

6.5.2 Actuator and Tray Based Trolley Table

This design uses a different technique to swap the discharged batteries from the van and also to place back the charged ones inside the rickshaw-van. Here a 12 volt actuator has been used. This actuator will be attached to the handle of the trolley table.

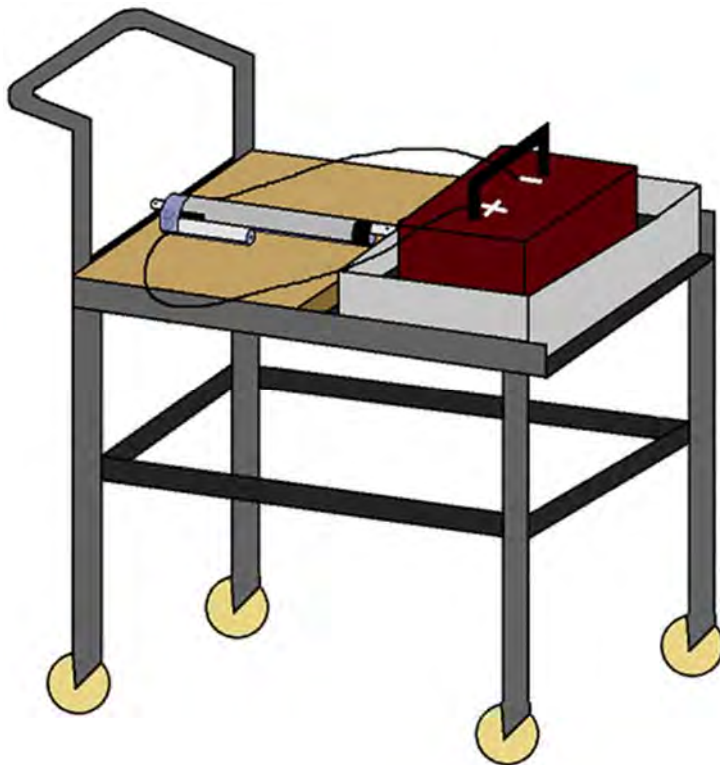

Fig.6.8 Actuator and tray based Trolley

The above Figure 7.3 illustrated the actuator and tray based trolley. 12 volt actuators are small in size and thus can be easily placed on the trolley table and attached to the handle. As the batteries used in our rickshaw-van are 12volt one, only a single battery is enough to power it up. Moreover 9 volt batteries can also power it up but in that case, it will move forward little bit slowly. There will also be a tray on the trolley-table on which batteries will be placed. There will be four wheels attached at the bottom of the trolley to make it easily movable and the legs are connected to one another with iron rods for a stronger structure.

6.5.3 Mechanism

The actuator is provided with 2 wires, one red and other black indicating +ve and -ve end. At first the trolley table is brought close to the vehicle. The small door on the side of the vehicle is opened and the table is merged to the van along the same height of the battery groove. The wheels below the trolley are locked so that it wouldn't fall back. The batteries inside the groove are placed on a tray and an actuator is also placed inside the groove taking proper measures. When the wires of the actuator are connected to the battery it will move forward and the tray will slowly be placed on the tray.

In the same way, when charged batteries need to be put inside the van, the trolley is brought close to the van and placed in such a way that it touches the outer side of the vehicle with the wheels locked below. When the wires on the actuator are connected to the battery, it moves forward. Thus the tray on the trolley table will also move forward and slowly be placed inside the battery groove. When we want to retract it, it can be stopped at any time and interchanging the +ve and -ve ends will make it move backward. This way discharged batteries can be taken out of the vehicle and charged batteries can again be placed inside it using an automated system.

6.5.4 Advantage of Proposed Design-II

- 12 volts actuator is powered by a single 12 volt battery
- No manual labour is done
- No physical strength is required
- Completely automatic
- Can uphold heavy load

6.6 Comments

Out of the two designs, DESIGN II is better for many reasons. These are as follows:

- Design II is completely automatic
- No hand lifting of battery is required
- Less manual labour
- Less physical strength spent
- Actuator requiring 12V is supplied by battery
- No extra voltage supply required
- Design II is much more expensive than design I

6.7 Conclusion

Swapping the batteries using the proposed new improved design trolley will make the whole process much easier and it requires comparatively less strength. These trolleys can be used effectively and efficiently. Less muscle power is required here, so that even aged people can do the swapping of batteries without facing much difficulty.

CHAPTER 7

Field Test

7.1 Objective

The objective of the field test was to determine the percentage of power saved from the battery by using solar panel to supply power to the vehicle and using torque sensor pedal to reduce the over-use of battery bank. The field test was carried out to obtain energy supplied by the panel, energy consumed from the battery and the energy consumed by the load. The multi-meters were used to determine voltage across the battery and PV panel. Clamp meter was used to measure current supplied by the panel and current supplied by the battery to the load.

The data was obtained during the peak sun hours from 12pm to 3pm. The test was conducted near the National Institute of Diseases of the Chest and Hospital area which had free road for running the rickshaw-van and sufficient amount of solar irradiation to determine the impact of the PV array on the performance of the rickshaw-van. The voltage and current readings for the PV array, the battery and the load were recorded. A GPS tracking system was used to estimate the average speed of the rickshaw-van and the distance travelled. The training manual is attached in Appendix G as a guide for new drivers.

The field test was carried out in four steps:

1. Without any PV array support and torque sensor pedal – the objective of the field test was to determine the distance that the rickshaw can travel with the battery discharged down to 50% SOC and the power consumed from the battery in full load condition.
2. With PV support only – to determine the distance that the rickshaw can travel with PV support with the battery discharged down to 50% SOC and obtain data to determine the load power shared by the battery and PV panel.
3. With torque sensor pedal only – to determine the distance that the rickshaw can travel with torque sensor pedal with the battery discharged down to 50% SOC and power consumed from the battery
4. With torque sensor pedal and PV support - to determine the distance that the rickshaw can travel with torque sensor pedal with the battery discharged down to 50% SOC and determine the load power shared by the battery and PV panel.

7.2 Data Acquisition Technique

The multi-meters were used to measure the voltage across the PV panel and the battery. One multi-meter was connected in parallel with 48V battery connected to the charge controller and the other one across the nodes connected to the charge controller. Clamp meter was clamped on to a wire connected in series with the panel to the charge controller and to

another wire connected in series with the battery and motor. A GPS tracking software was used in order to determine the distance travelled by the vehicle and the average speed of the vehicle. All the tests were carried out at full load conditions. All these readings were recorded by a video camera throughout the field tests. The data were retrieved from the video camera at 20 seconds time interval.

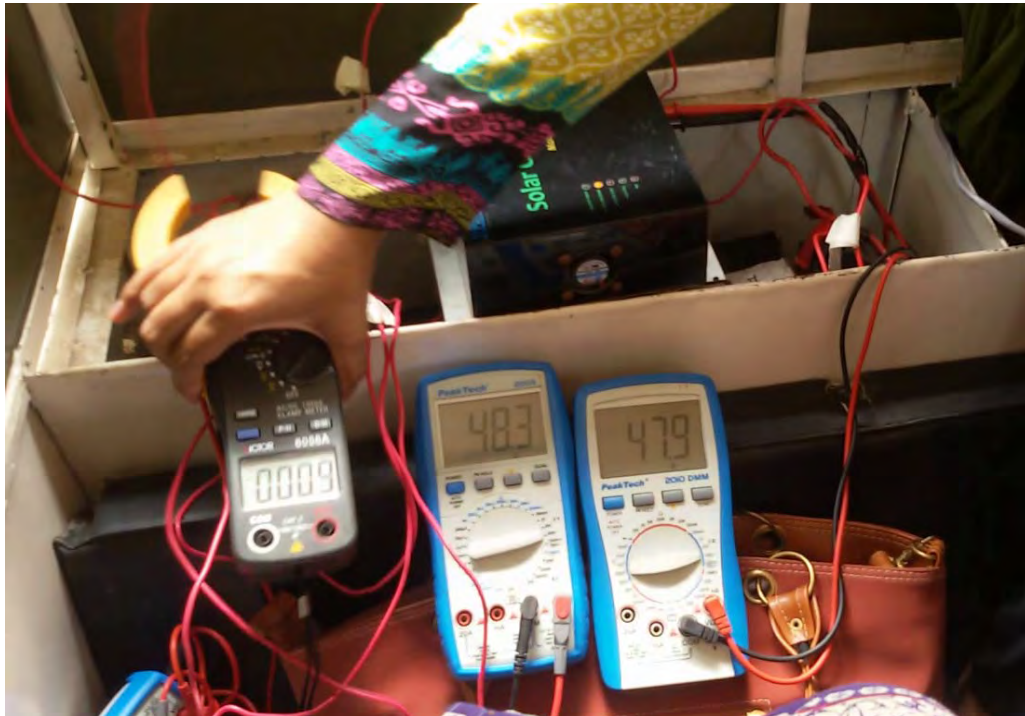

Fig 7.1 Data acquisition technique

7.3 Field Test Data without PV Support and Torque Sensor

At first stage of research, field test was carried out without any PV support and torque sensor pedal and data were obtained. During the test, voltage across battery and load current were recorded. The data was then retrieved from the video camera and used to compile the following graphs. The data obtained from the field test are attached in the **Appendix C TABLE 1**. Fig 7.2 represents the battery supply profile. Battery current and battery voltage obtained during the test is represented in Fig 7.2. Fig 7.3 represents the battery power [voltage*current]. Fig 7.4 is the graphical representation of load power. Battery power is equal to load power.

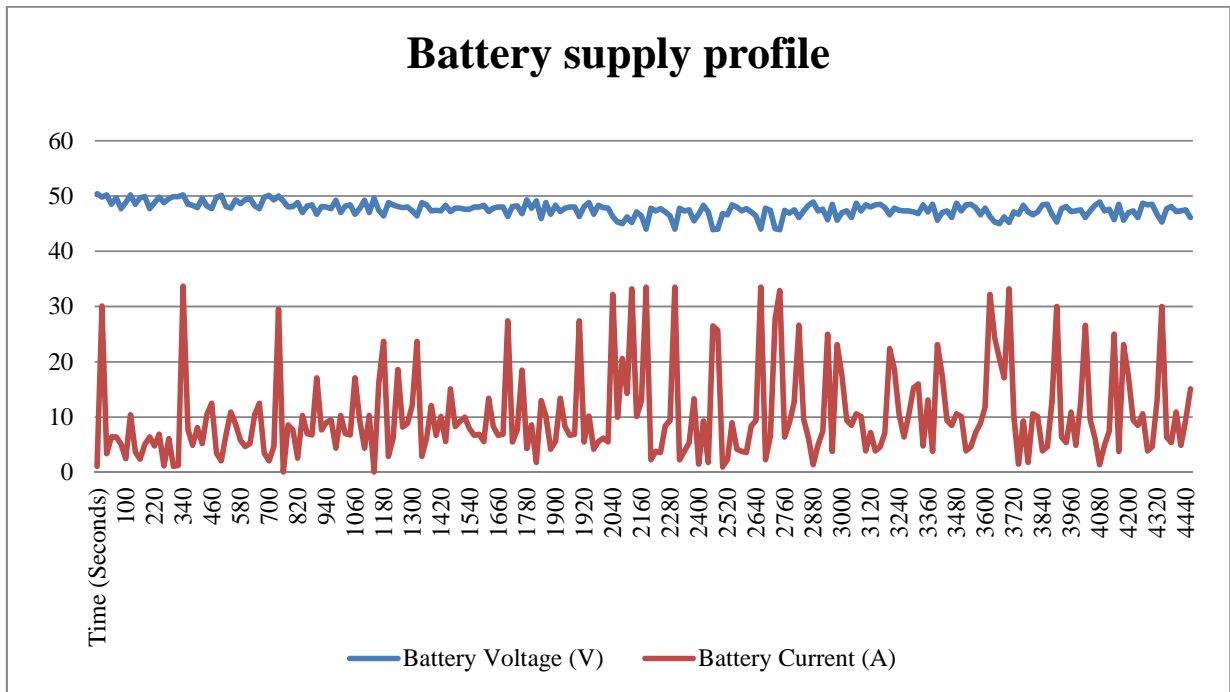

Fig 7.2 Battery supply profile

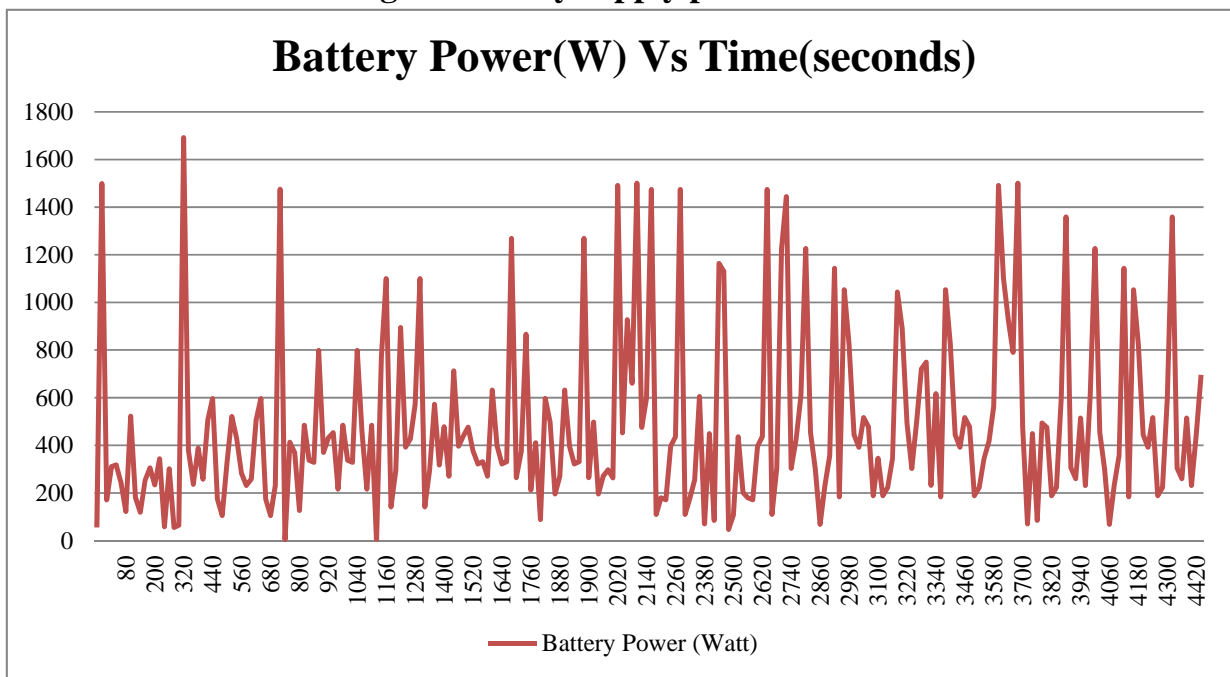

Fig 7.3 Battery power (watts) vs. time (seconds)

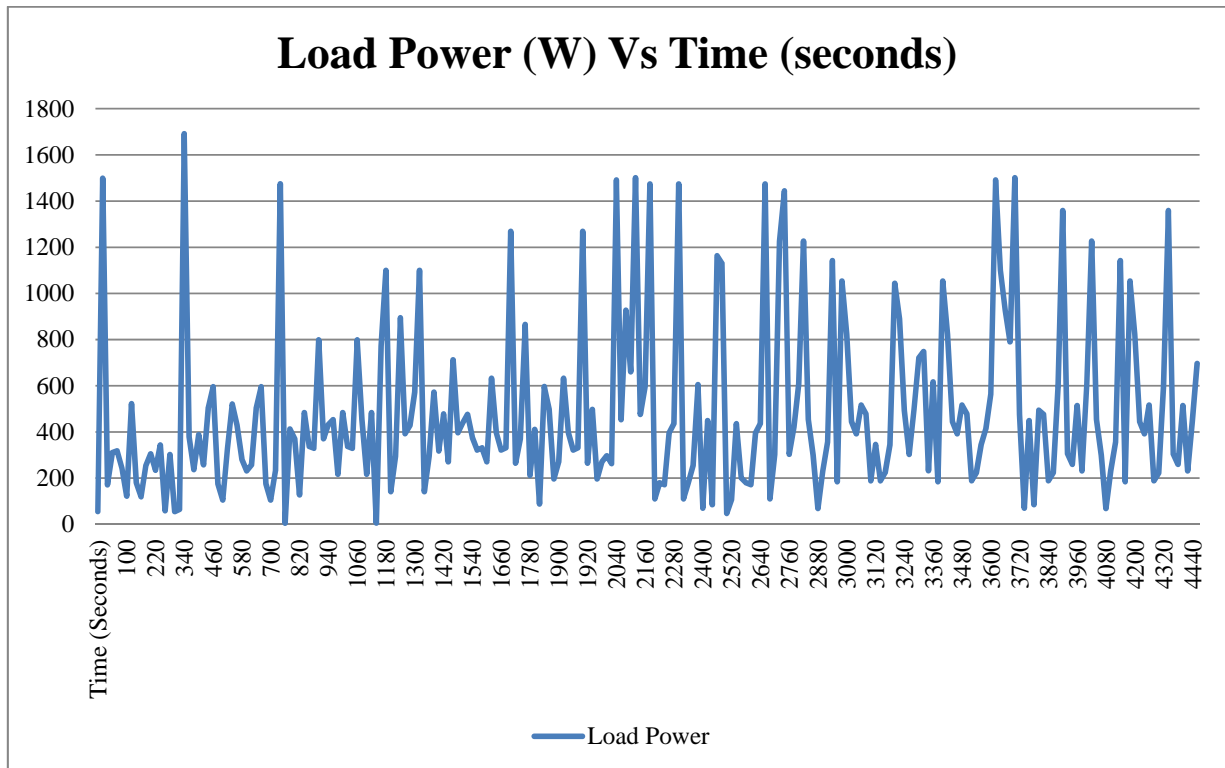

Fig 7.4 Load power (watts) vs. time (seconds) without PV support and torque sensor

The graph of battery power (watts) vs. time (seconds) is used to calculate the energy consumed from the battery bank. In this case, the energy supplied by the battery is equal to the energy consumed by the load. Therefore, battery power supplied is equal to load power consumed. The area under the graph in Fig 7.4 is used to calculate the energy consumed by the load from the battery. Since there was no PV support and torque sensor pedal in this test, so the energy supplied by the battery is equal to the energy consumed by the load. The energy consumed by the load from battery is **2183600.3 Joules**.

7.4 Field Test Data with PV support only

At second stage of research, field test was carried out with PV support only and torque sensor pedal was not used. The test was carried out during the peak sun hours from 12pm to 3pm. Voltage across the panel and battery, current drawn by the load from battery and current supplied by the panel were record using a video camera and later again retrieved at 20 seconds interval and used to compile the following graphs. The data obtained from the field test are attached in **Appendix D: TABLE 2**. Fig 7.5 shows the PV supply current and voltage and it is represented in a single graph. Fig 7.6 represents the battery supply profile and Fig 7.7 represents the load profile during the test.

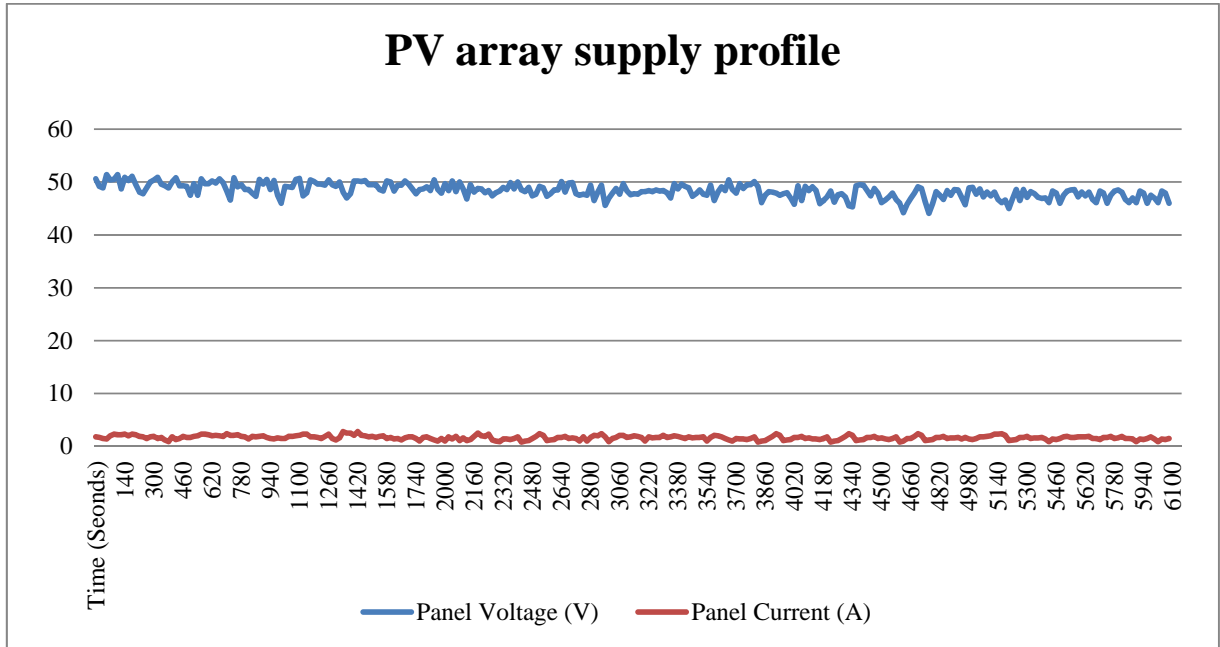

Fig 7.5 The PV array supply profile

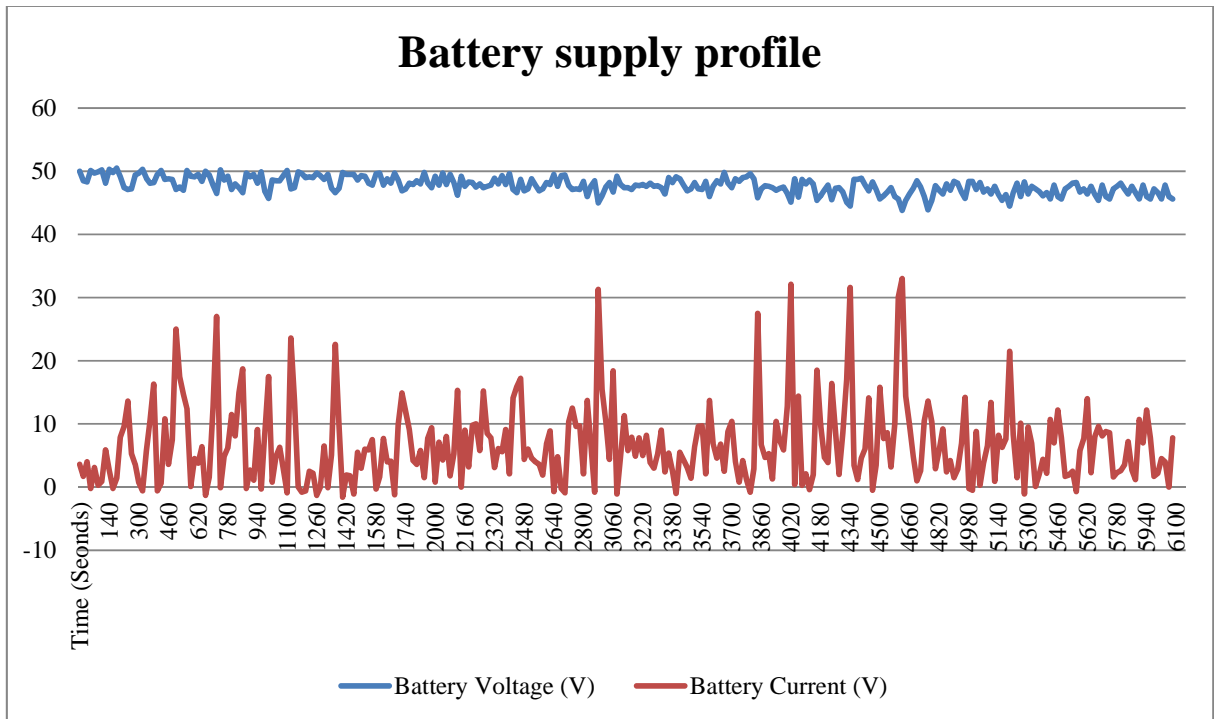

Fig 7.6 The battery supply profile with PV support

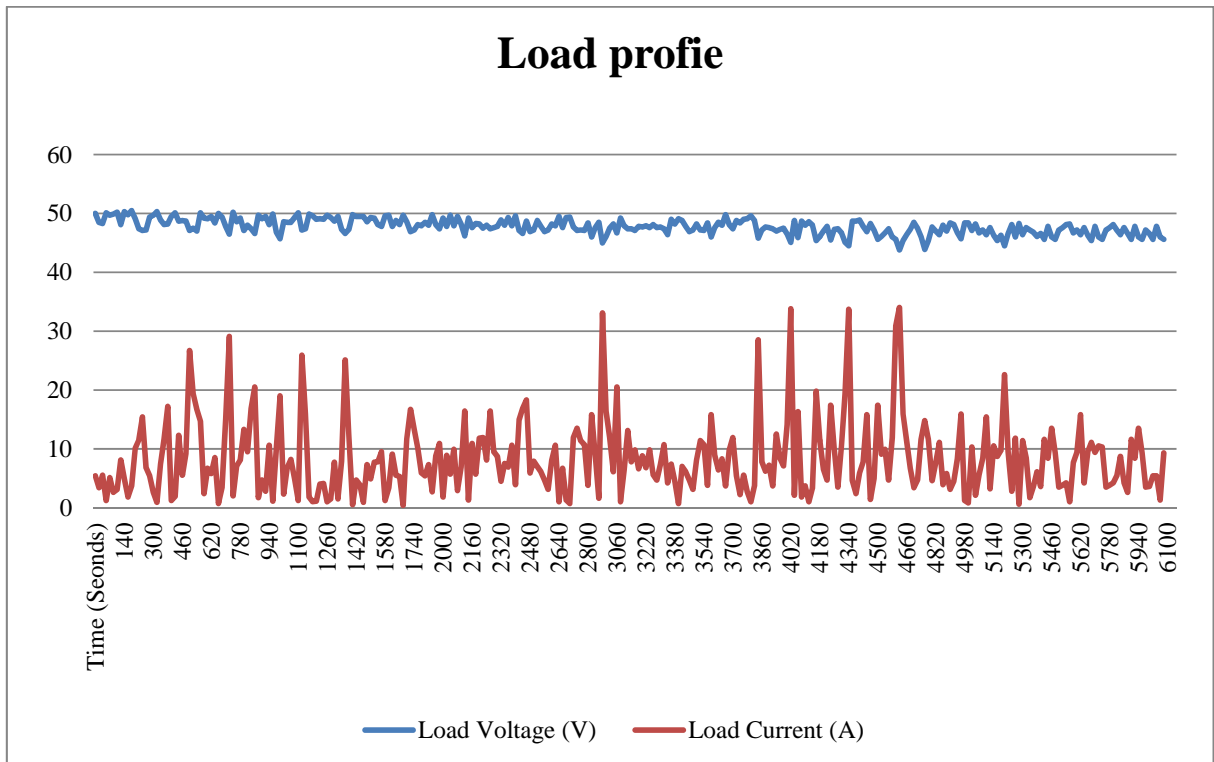

Fig 7.7 The load profile of the rickshaw-van

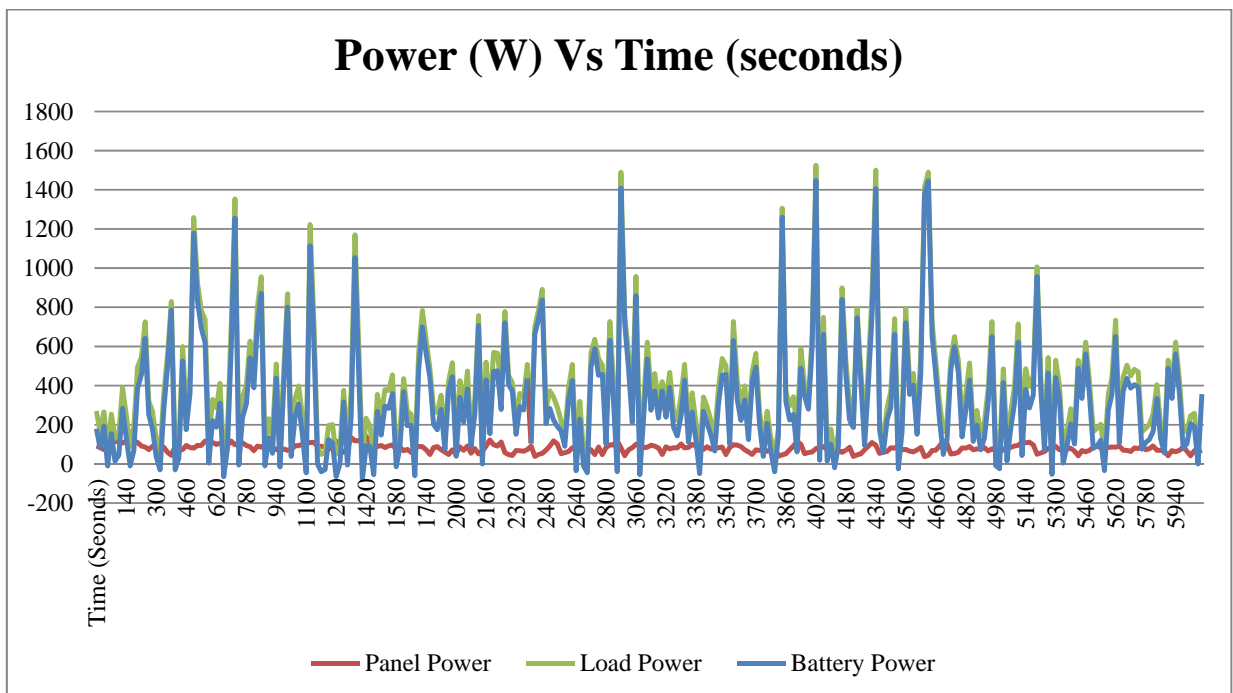

Fig 7.8 Comparison of load power (watts), battery power (watts) and panel power (watts) with respect to time (seconds)

The area under the graph of panel power (watts) vs. time (seconds) in Fig 7.8 is used to determine the energy supplied by the panel and the graph of battery power (watts) vs. time (seconds) is used to determine energy supplied by the battery. The area under the graph of load power (watts) vs. time (seconds) is used to determine the energy consumed by the load. The energy supplied by the panel estimates to **489483.9Joules** and the energy consumed from the battery estimates to **1941396 Joules**. The energy consumed by the load is **2420743 Joules**. From the result obtained we can calculate the sharing of total power supplied by the panel and the batteries. It is estimated that **20.1%** energy is supplied by the panel and the rest **79.9%** energy is supplied by the battery.

7.5 Field Test Data with Torque Sensor only

Field test was carried out with torque sensor pedal to determine the distance travelled by the vehicle up to battery discharged down to 50% SOC and the power consumed from the battery. Voltage across the battery and current drawn by the load were recorded. The data obtained from the field test are attached in **Appendix E TABLE 3**. The torque sensor input voltage to the controller unit and output voltage from the torque sensor pedal to the torque adjuster were recorded and represented in Fig 7.9. All the data were recorded with the help of a video camera and later retrieved at 20 second interval and used to compile the following graphs. Fig 7.10 represents the battery supply current and voltage. Fig 7.11 represents battery power [voltage* current]. Battery is supplying power to the load and therefore battery power is equal to load power and represented in Fig 7.12.

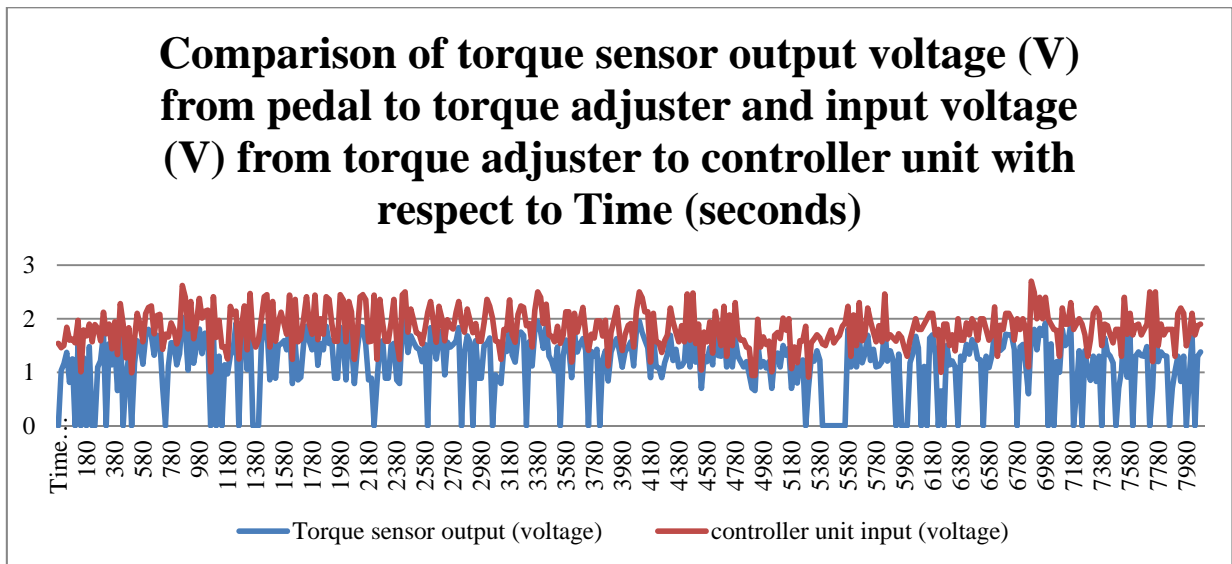

Fig 7.9 Comparison of torque sensor output voltage (volts) from the pedal to the torque adjuster circuit and input voltage(volts) from torque adjuster circuit to controller unit with respect to time (seconds)

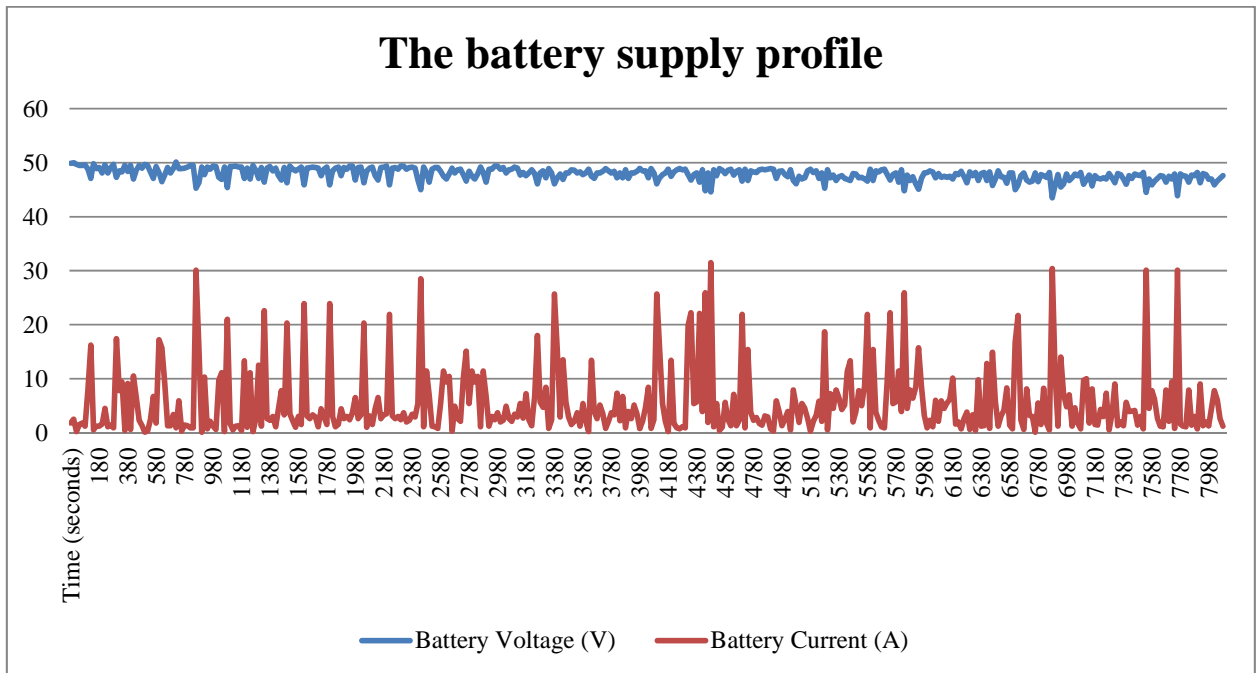

Fig 7.10 The battery supply profile with torque sensor pedal

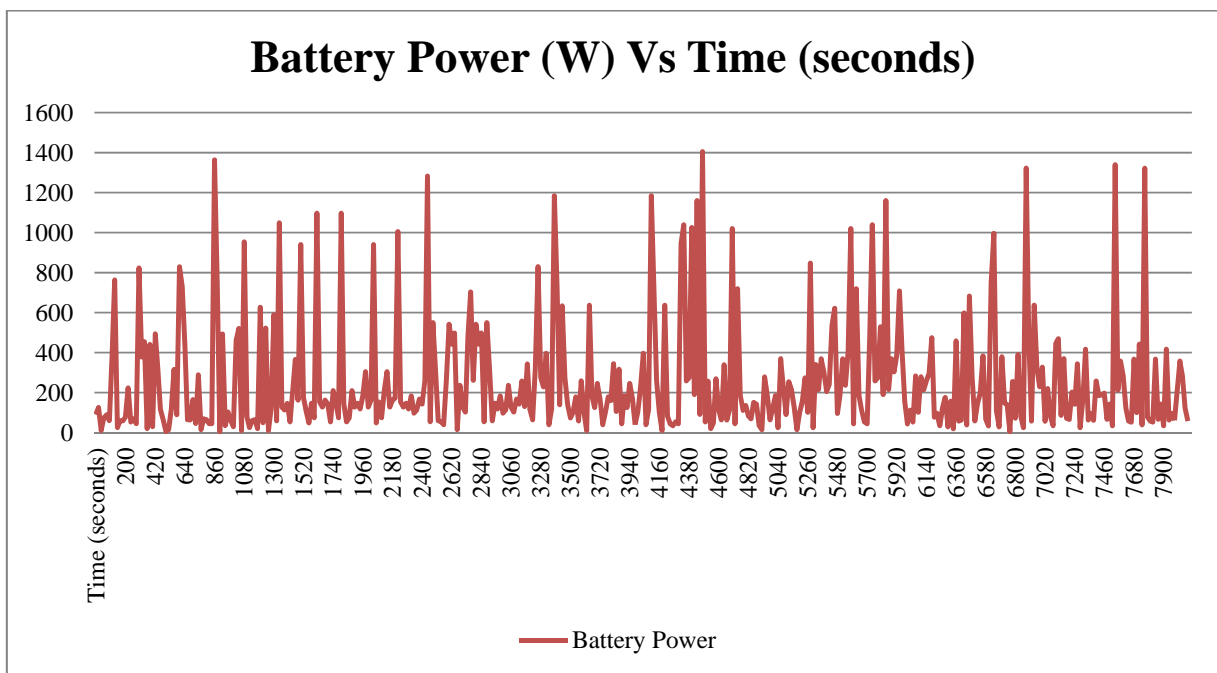

Fig 7.11 Battery power (watts) Vs time (seconds)

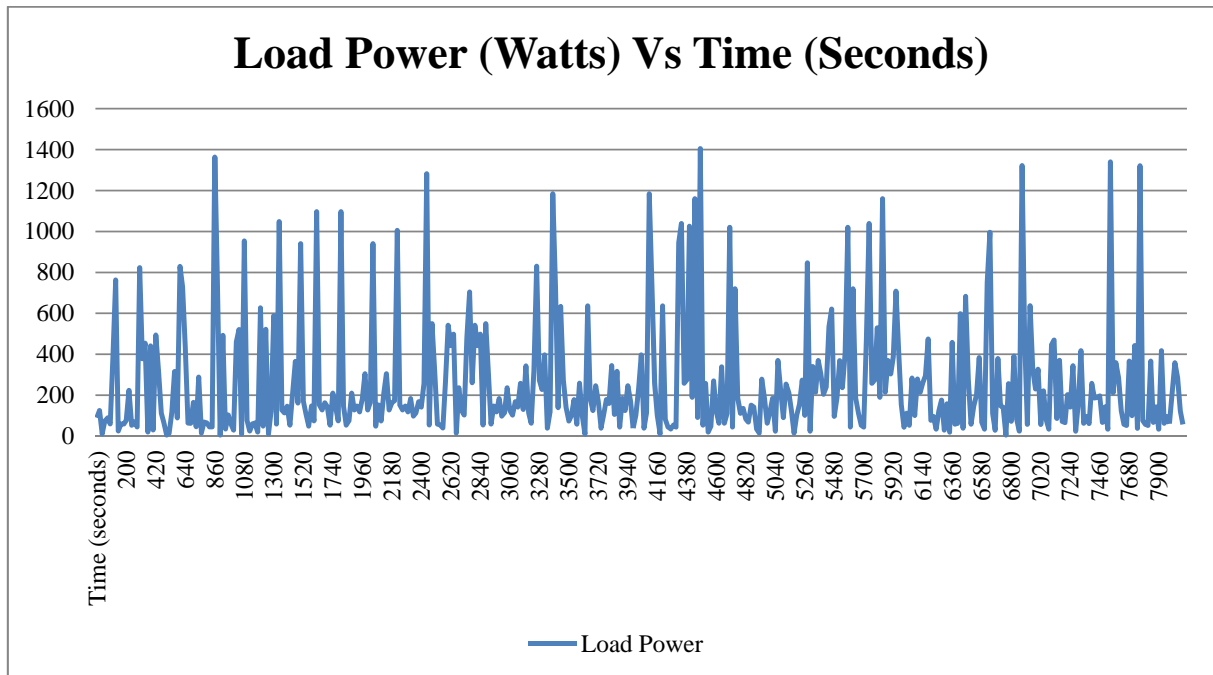

Fig 7.12 Load power (watts) Vs time (seconds)

Here, energy supplied by the battery is equal to the energy consumed by the load. The graph of battery power (watts) vs. time (seconds) in Fig 7.11 is used to calculate the energy consumed from the battery bank. The total energy supplied by the battery during the test without torque sensor and PV support was **2183600.3 Joules** and within 4480 seconds the battery discharged down to 50% SOC. But during the test with torque sensor only and no PV support, it took 8100 seconds for the battery to discharge down to 50% SOC. The energy supplied by the battery up to 4480 seconds during the test with torque sensor and no PV support is **1181021 Joules**.

7.6 Field Test Data with both PV Support and Torque Sensor

The test was carried out until the battery discharged down to 50% (SOC). Panel current, panel voltage, current drawn by the load, load voltage, the torque sensor input voltage to the controller unit and output voltage from the torque sensor pedal to the circuit were recorded. All these data were recorded with the help of video camera and later retrieved at 20 second interval and used to compile following graphs. The data obtained from the field test are attached in **Appendix F TABLE 4**. Fig 7.13 represents the PV array supply profile, Fig 7.14 represents the battery supply profile and Fig 7.15 represents load profile. Fig 7.16 represents panel power, battery power and load power in a single graph.

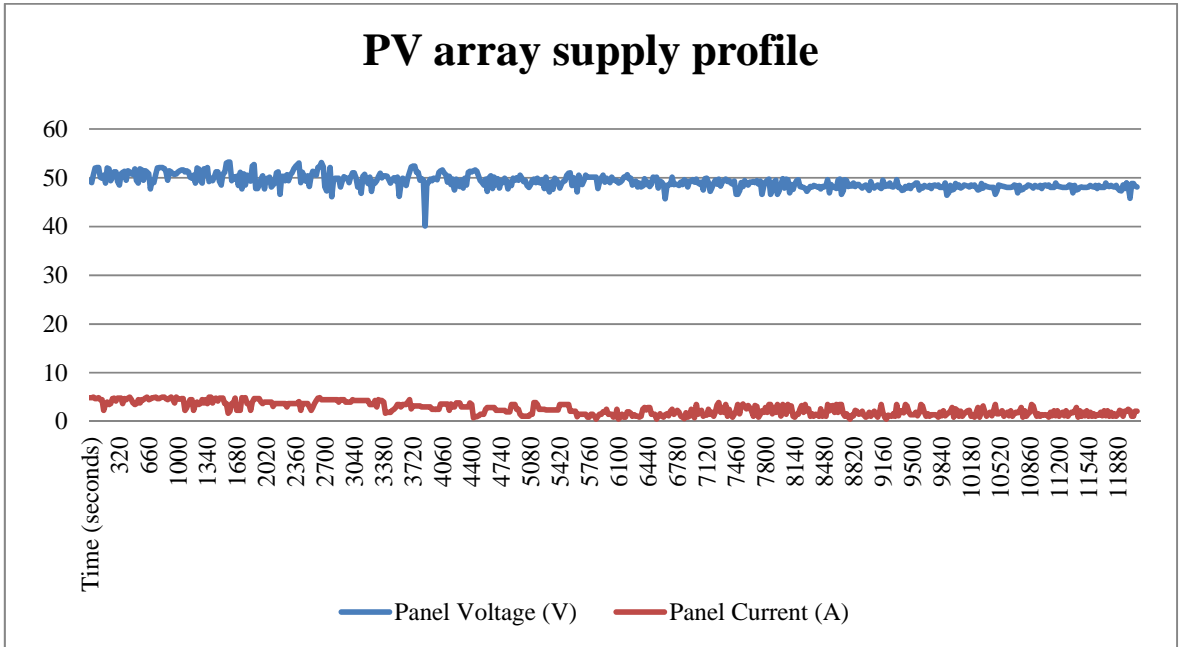

Fig 7.13 PV array supply profile

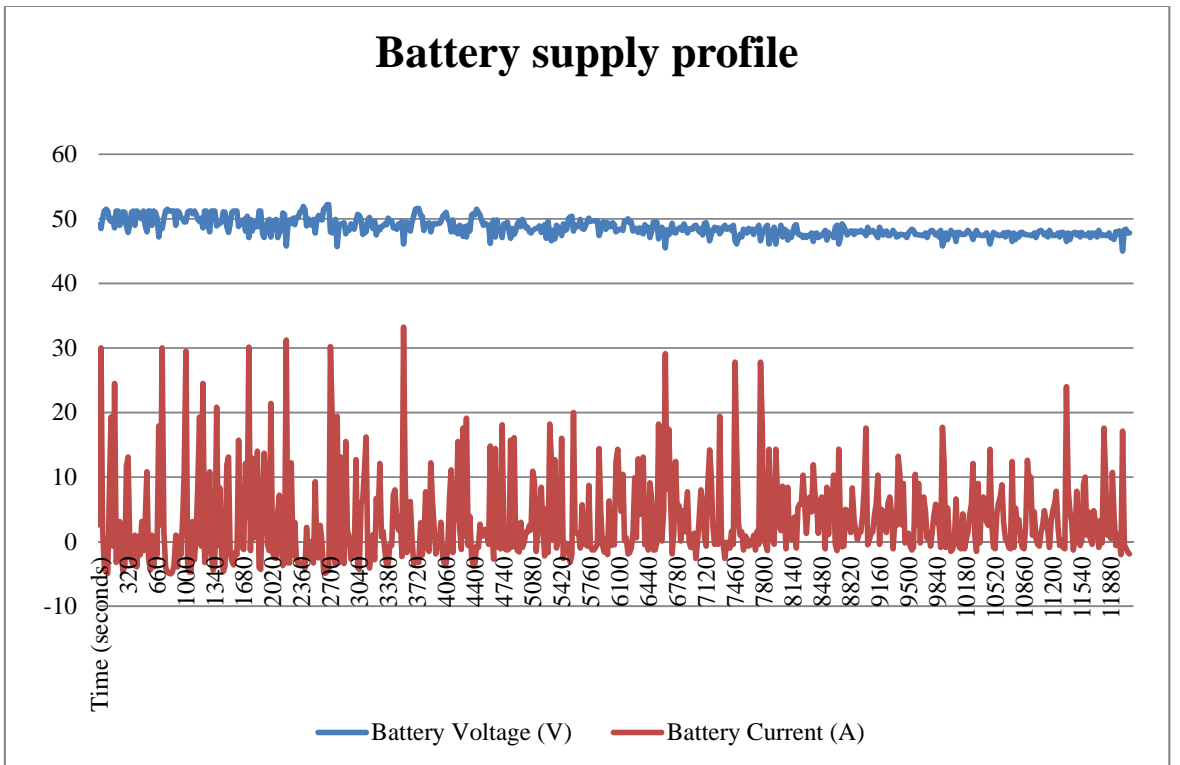

Fig 7.14 Battery supply profile

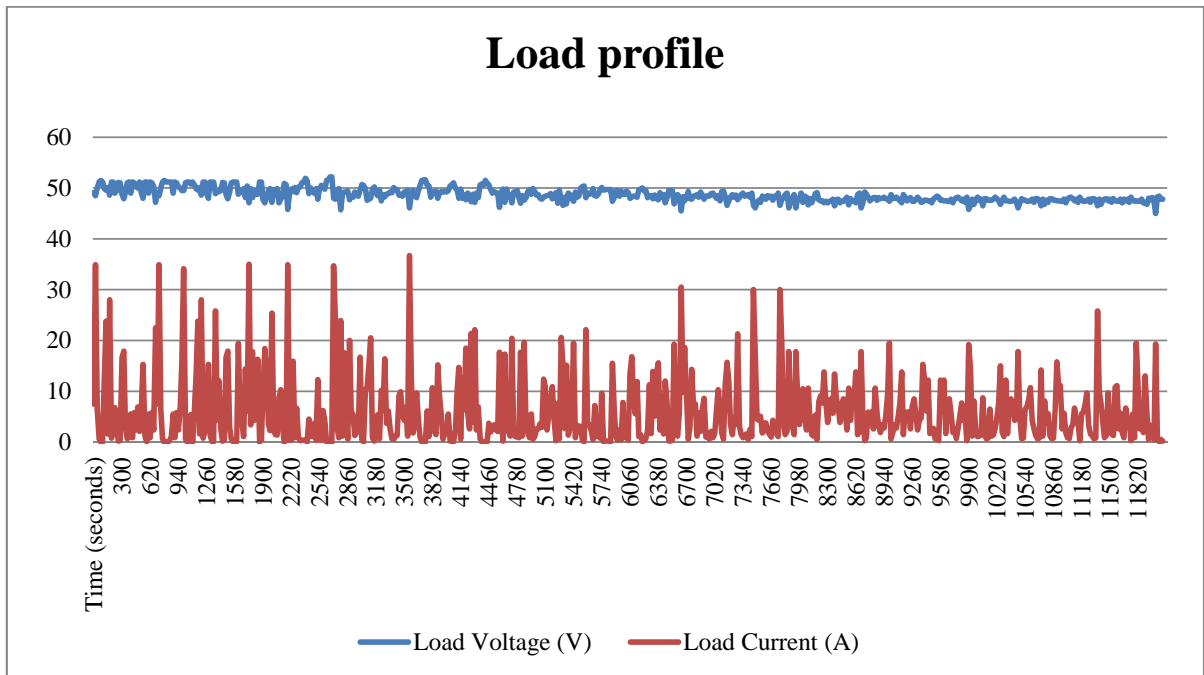

Fig 7.15 Load profile

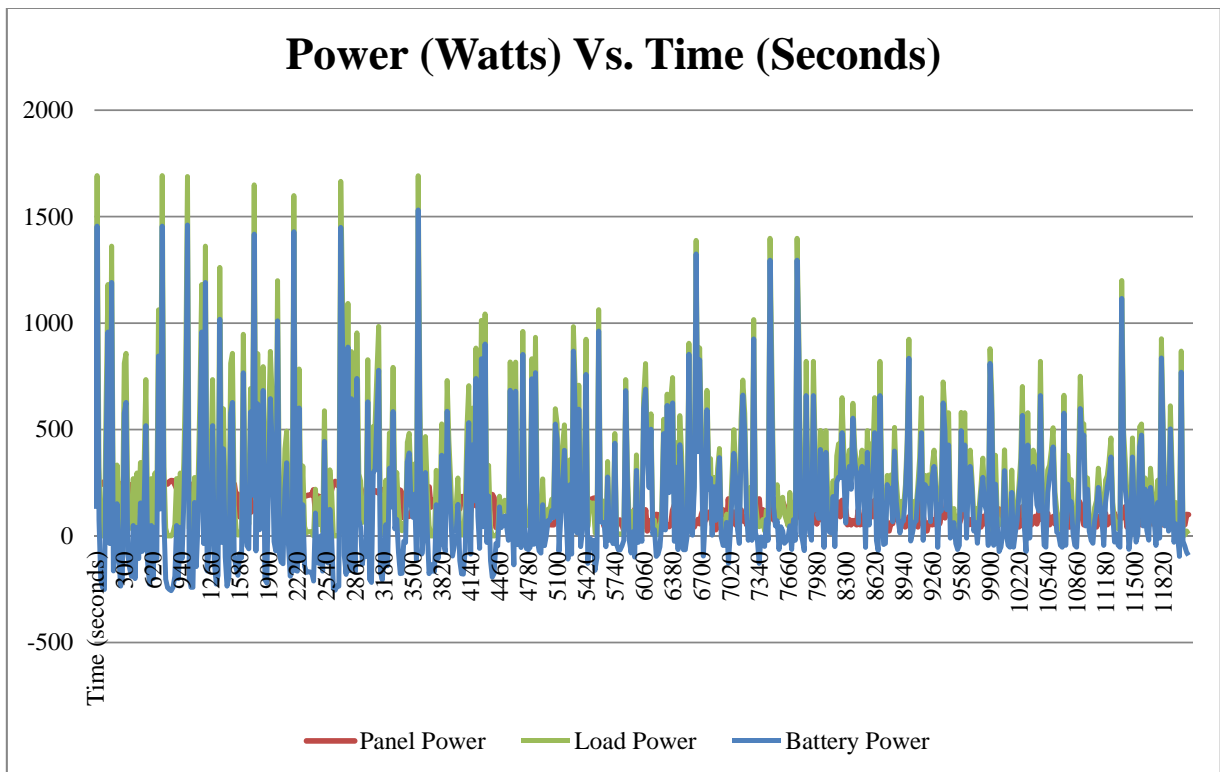

Fig 7.16 Comparison of panel power (watts), load power (watts) and battery power (watts) Vs time (seconds)

The area under the panel power curve, load power curve and battery power curve will give the energy supplied by the panel, energy consumed by the load and energy supplied by the battery respectively. From the calculations, it is estimated that the energy supplied by the panel was **1563291 Joules**, energy supplied by the battery was **1963950 Joules** and the energy consumed by the load was **3508080 Joules**. The energy supplied by the battery upto 4480 seconds is **575671.4 Joules**.

7.7 Comparative Study

7.7.1 With PV Support only Vs. Without PV Support and Torque Sensor

The field tests were carried out until the battery discharged to 50% SOC. The results obtained from the two field tests reveal that the vehicle can travel **17.2 km in 1.69hrs (6100 seconds) with PV support only** and the vehicle can travel **12.455km in 1.24hrs (4480 seconds) without PV support and torque sensor**. The test reveals that 20.1% energy is supplied by the PV array and the rest of the energy is supplied by the battery and thus 20.1% is saved. The following Fig 7.17 and the results of projected distance travelled in Fig 7.18 reveals that the presence of PV panel has significant impact on the performance of the vehicle.

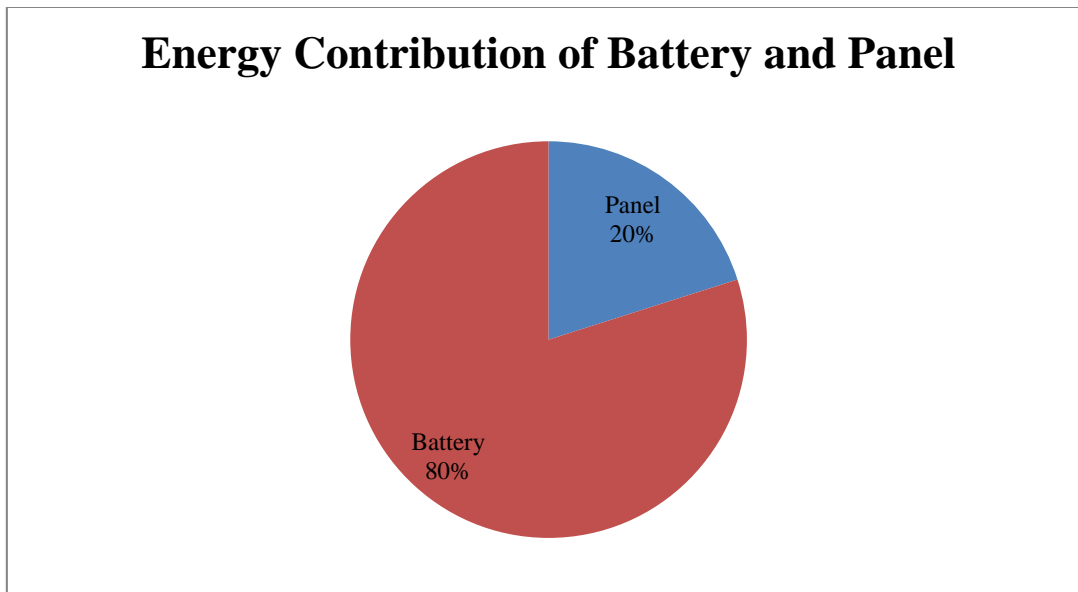

Fig 7.17 Power contribution of battery and panel

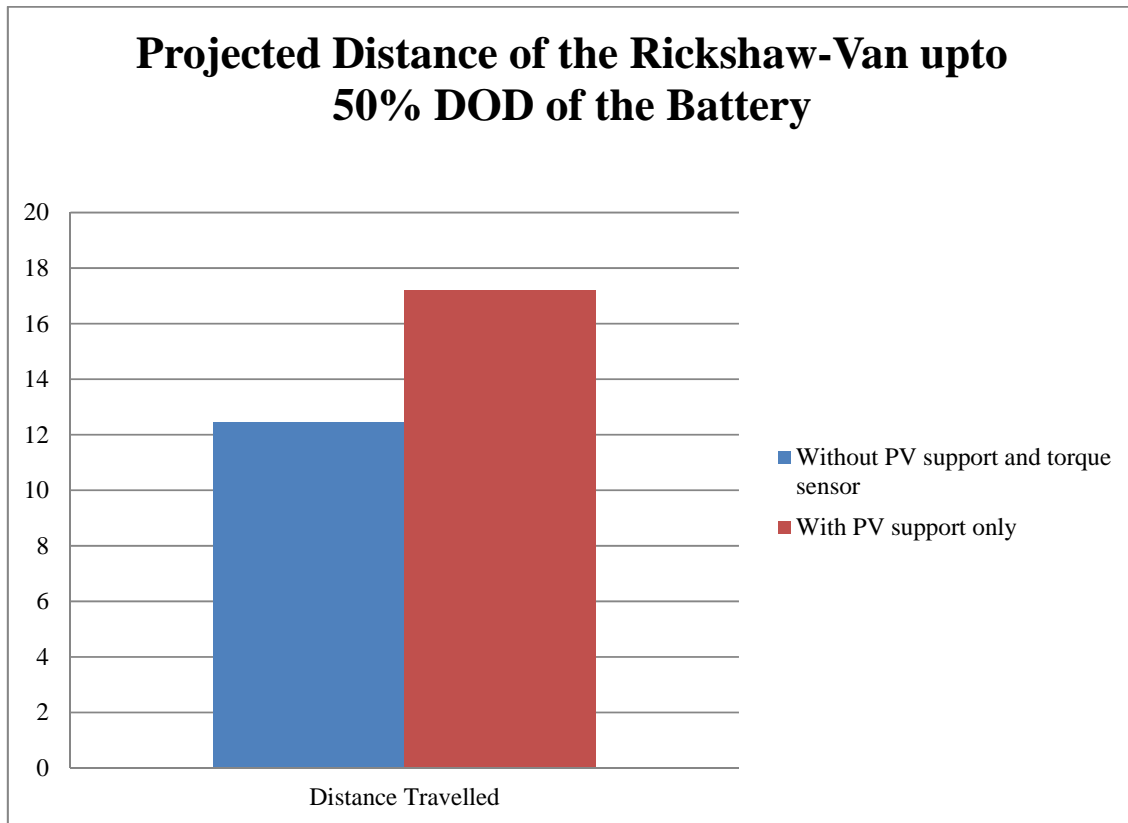

Fig 7.18 Projected distance of the rickshaw-van upto 50% DOD of the battery

7.7.2 Without PV Support and Torque Sensor Vs. With Torque Sensor

The results obtained from the field tests reveal that the vehicle can travel **12.455km in 1.24hrs (4480 seconds) without PV support and torque sensor** whereas the vehicle can travel **23.75km in 2.25 hrs with torque sensor pedal**. Fig 7.19 represents the projected distance of the rickshaw-van upto 50% DOD of the battery during the test with torque sensor pedal and without torque sensor and PV support. The graph in Fig 7.20 reveals that with the use of torque sensor pedal, the overuse of the battery bank has reduced. The area under the battery power curve with torque sensor is less than the battery power curve without torque sensor and PV support.

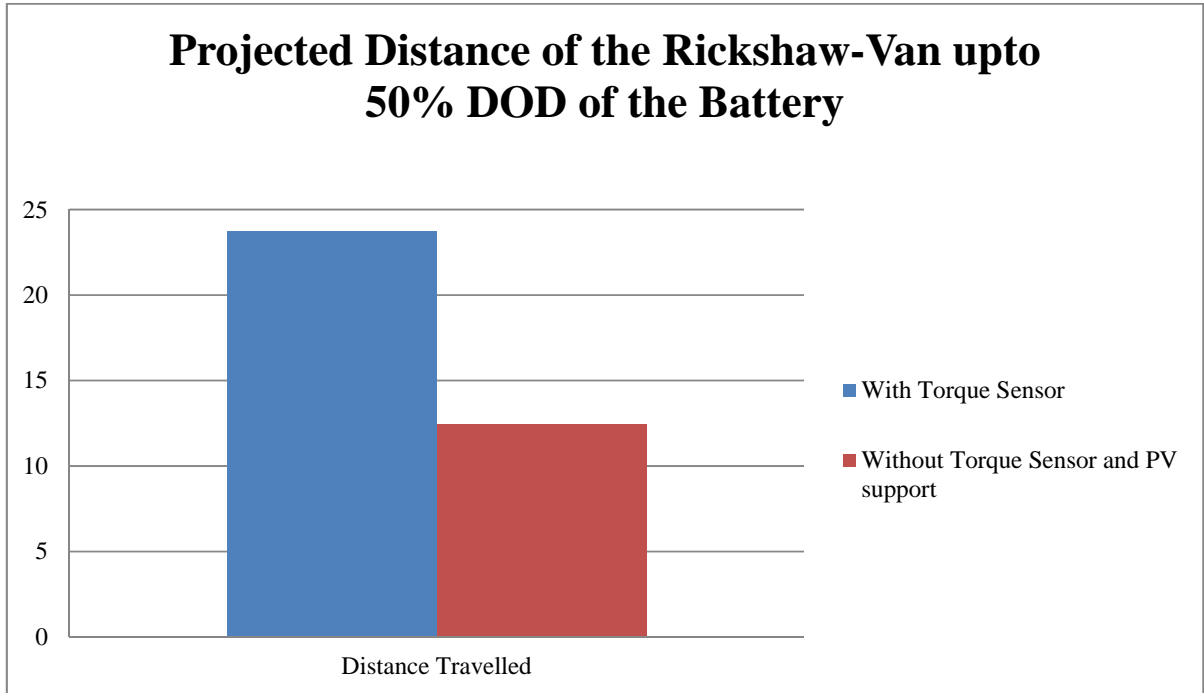

Fig 7.19 Projected distance of the rickshaw-van upto 50% DOD of the battery

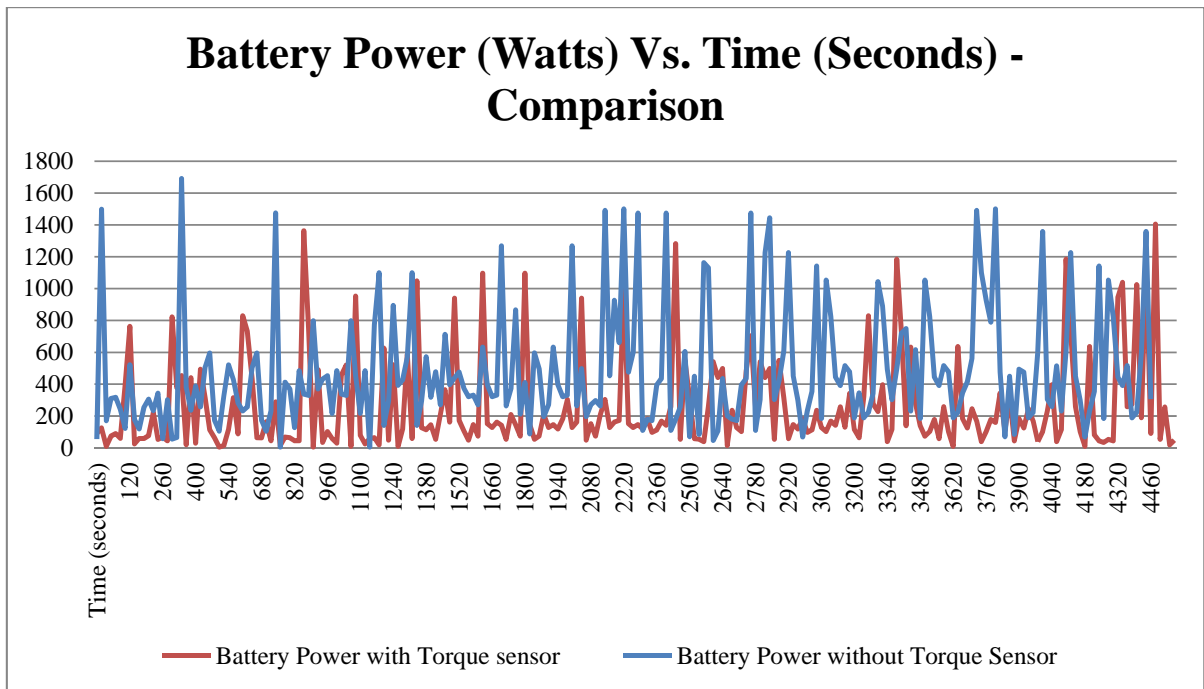

Fig 7.20 Comparison of battery power consumed with throttle system and torque sensor

The battery power curves are used to determine the energy consumed by the system using throttle and torque sensor. The battery was discharged upto 50% SOC within 4480 seconds with throttle whereas with torque sensor pedal it was found that the battery still had more than 75% charge (SOC). From the power curves, it is estimated that the energy consumed from the battery with throttle system within 4480 seconds is **2183600.9 Joules** and the energy consumed from the battery with torque sensor pedal in the system within 4480 seconds is **1181021 Joules**. Thus, we can say that with torque sensor pedal integrated into the system, the system consumes **54.1%** energy of the throttle controlled design and it saves **45.9%** energy. Fig 7.21 represents the comparison between the energy saved with torque sensor and without torque sensor and PV support.

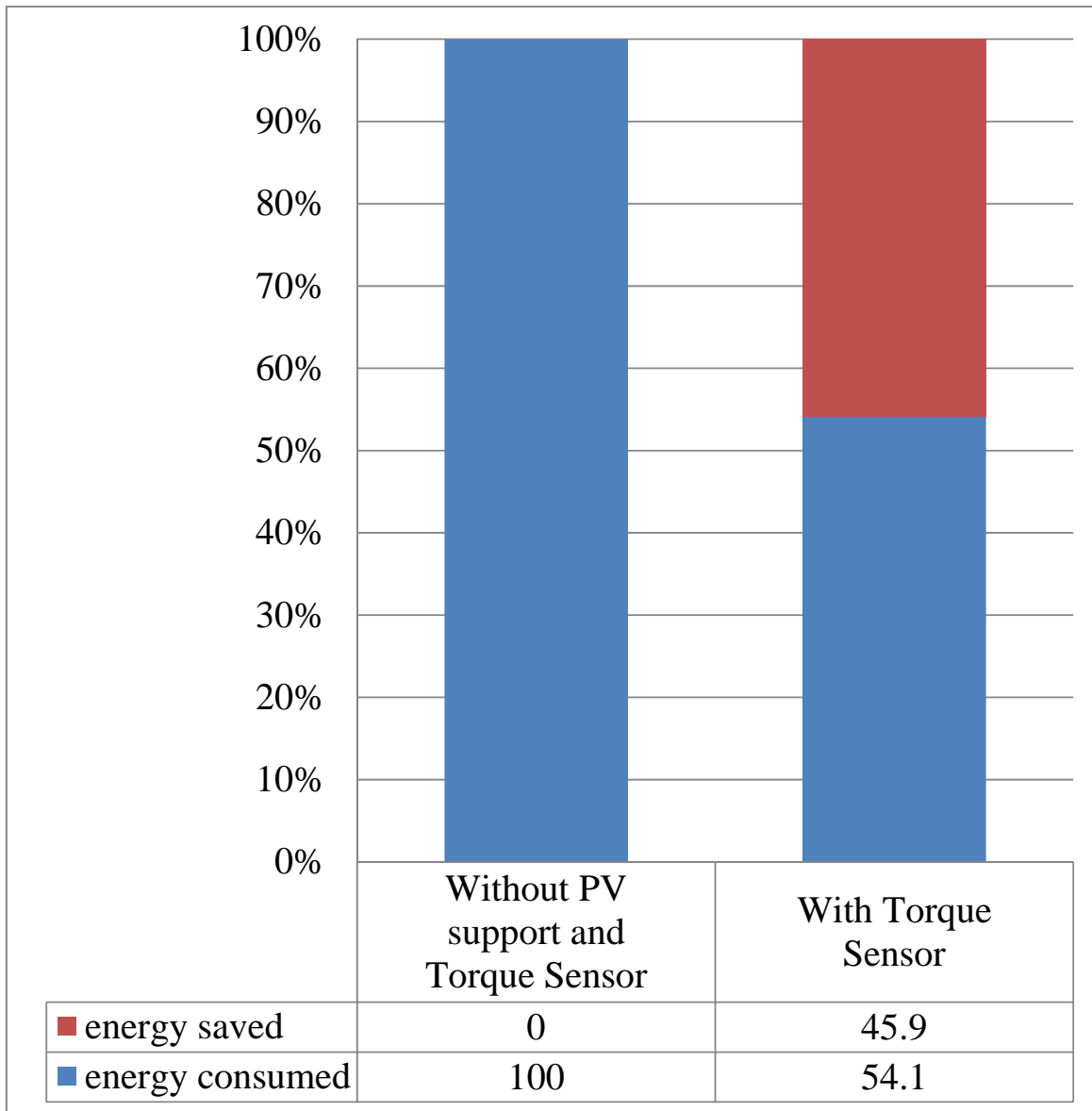

Fig 7.21 Comparison between energy saved with torque sensor and without PV support and torque sensor

7.7.3 Without PV Support and Torque Sensor Vs. with both PV Support and Torque Sensor

The result obtained from the field test with both torque sensor and PV support reveals that the vehicle can travel **35.49km in 3.36 hrs (12120 seconds)** whereas the vehicle can travel **only 12.455km in 1.24 hours (4480 seconds)** without PV support and torque sensor. The result is represented in Fig 7.22.

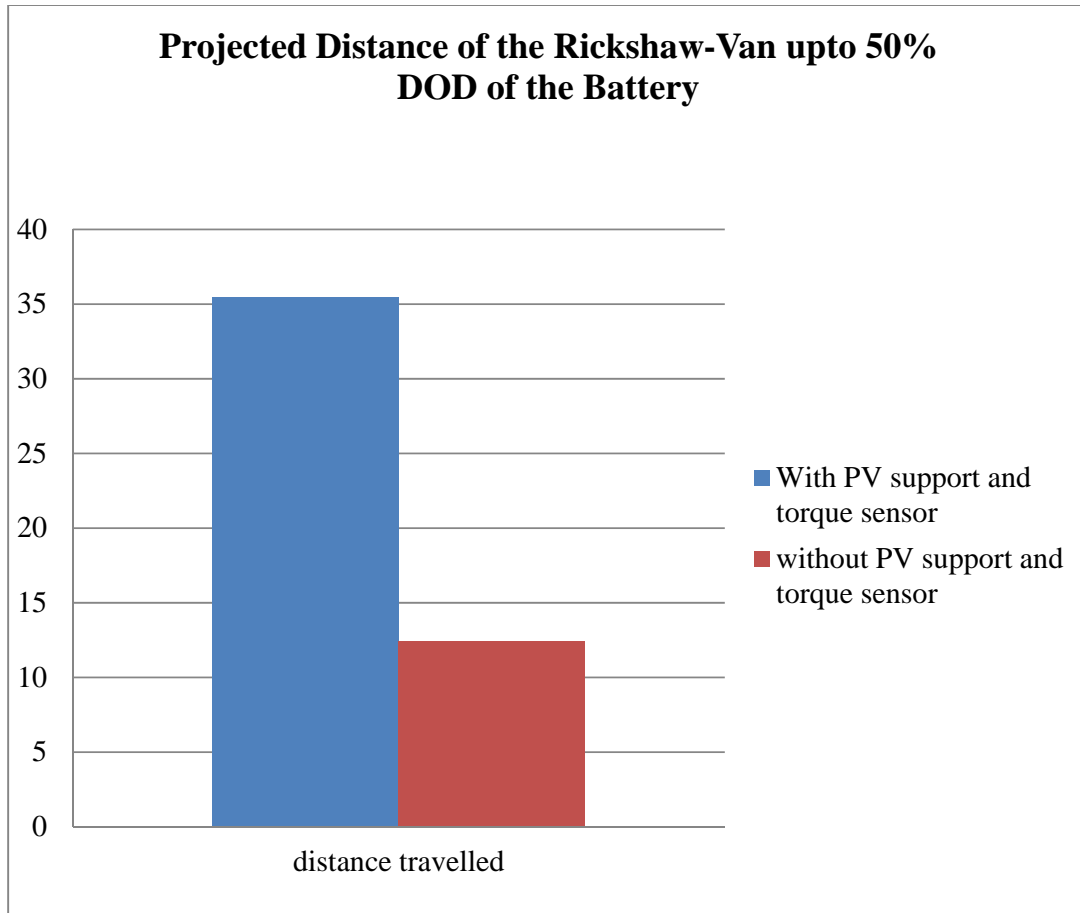

Fig 7.22 Projected distance of the rickshaw-van upto 50% DOD of the battery

From the battery power curves, it is determined that energy supplied by the battery during the test with both PV support and torque sensor was **1963950 Joules in 3.36 hours (12120 seconds)**. The energy supplied by the battery was **575671.4 Joules in 1.24 hours (4480 seconds)**. The energy supplied by the battery during the test without PV support and torque sensor was **2183600.9 joules in 1.24 hours (4480 seconds)**. Thus, from the calculations we can say that the system consumed **26.3%** energy of the throttle controlled design and with PV support and torque sensor, it saves **73.6%** energy. Fig 7.23 represents the comparison between energy consumed and energy saved with torque sensor and with both PV support

and torque sensor. Fig 7.24 represents the comparison of distance travelled by the rickshaw- van upto 50% DOD in all four field tests.

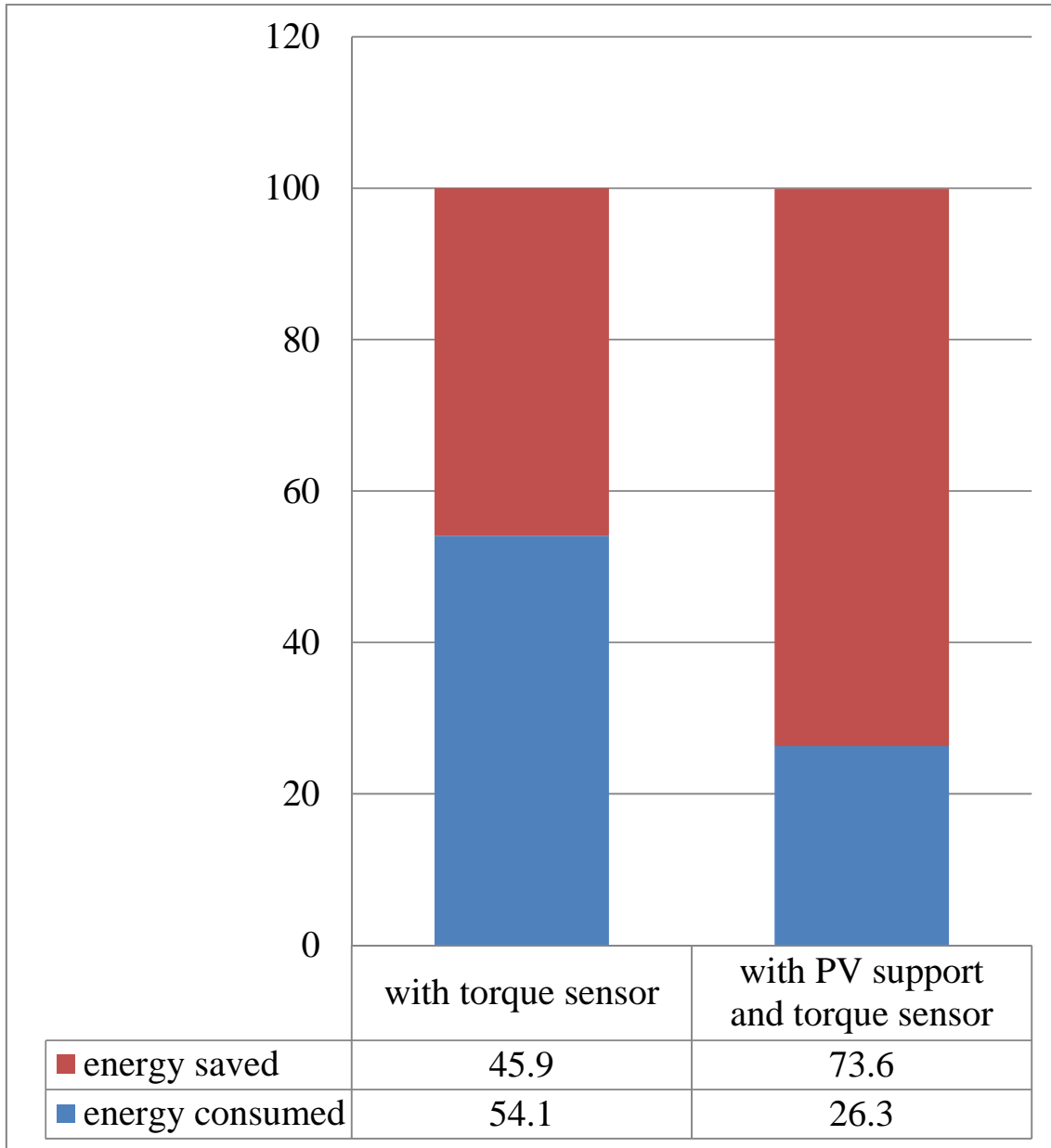

Fig 7.23 Comparison Between Energy Consumed And Energy Saved With Torque Sensor And With Both PV Support And Torque Sensor

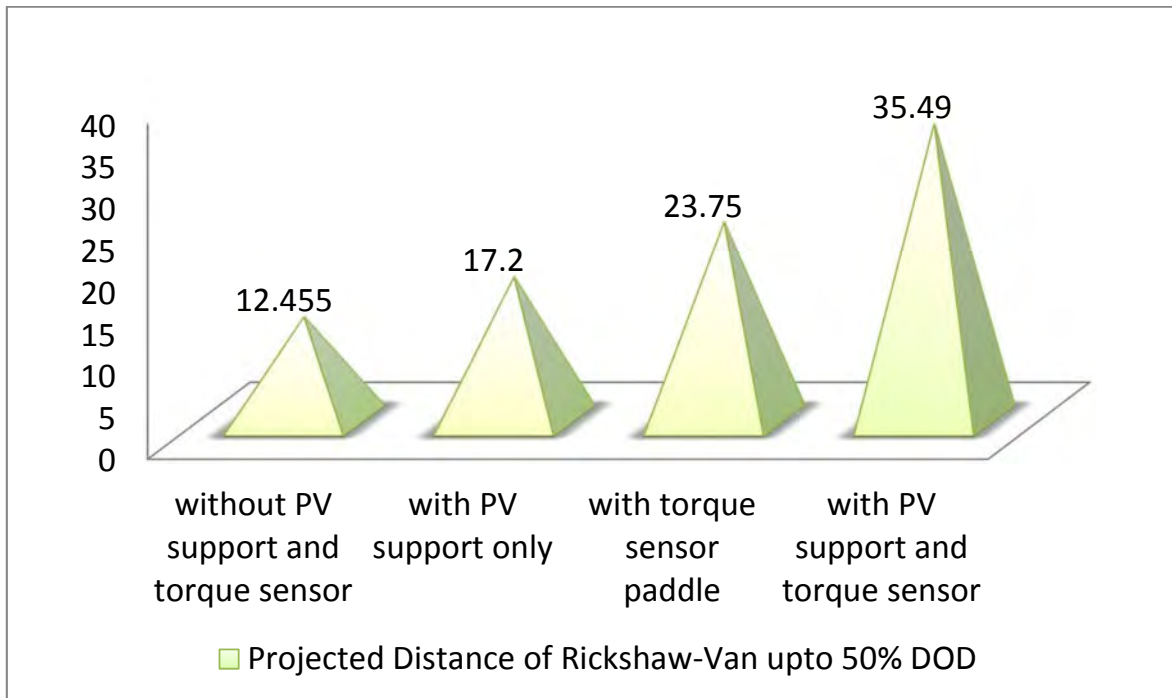

Fig 7.24 Comparison of distance travelled by the rickshaw-van upto 50% DOD

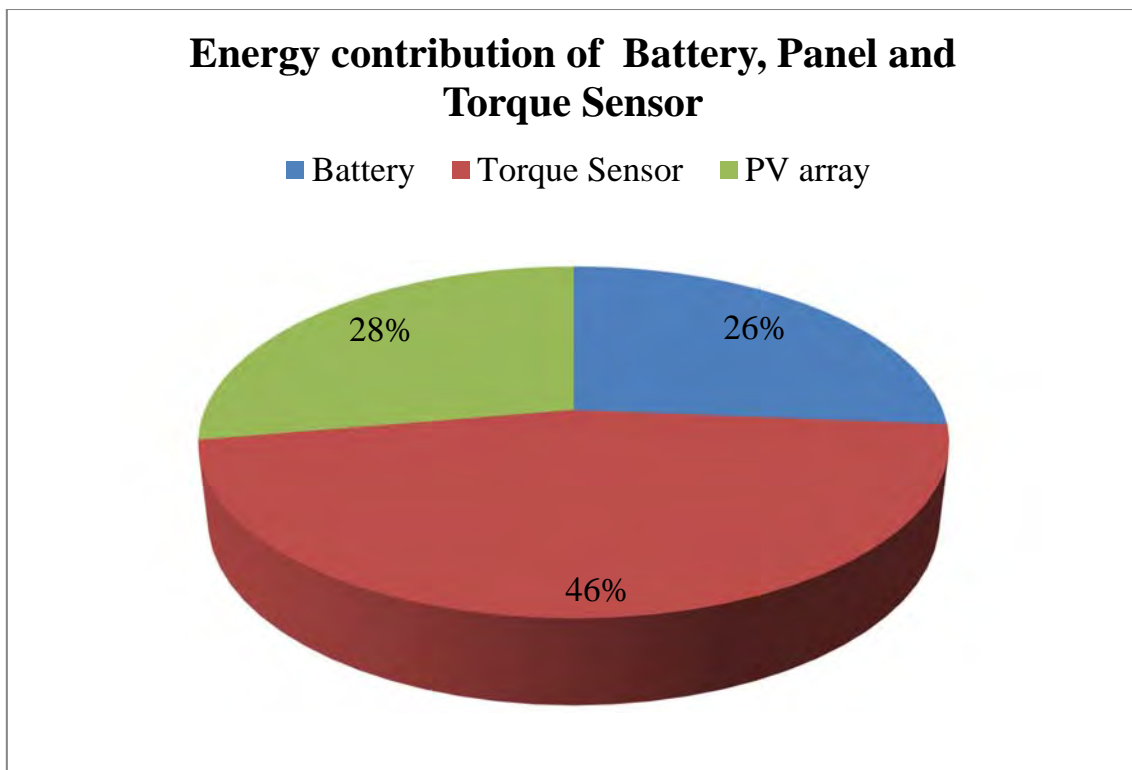

Fig 7.25 Energy contribution of battery, panel and torque sensor

7.8 Conclusion

The chapter quantitatively proves that the use of both PV array and torque sensor in rickshaw-van has significant impact on the performance of the vehicle. The distance travelled by the vehicle with both PV support and torque sensor is 2.8 times greater than normal battery operated rickshaw-van and thus this system lengthens the battery lifetime. From the final result, it is estimated that around 73.6% energy is saved with both PV array and torque sensor in the system where torque sensor contributes to saving 45.9% energy and PV array contributes to saving 27.7% energy.

CHAPTER 8

Conclusion

8.1 Summary

After a year of research, our project *Power conservation for electrically assisted rickshaw-vans with PV support, torque sensor pedal and the solar battery charging station- A complete off-grid solution* was a success. The objective of this project is to develop the motorized rickshaw-van more efficient with the use of both PV array and torque sensor pedal in the system and make the whole system independent of national grid. The results obtained from the field tests have proved that the vehicle is significantly efficient than all other commercial models. It increases the lifetime of the battery and thus sustain longer. The efficiency enhances the opportunities of future work.

8.2 Future Work

The basic goal of the whole project was to transform the existing traditional rickshaw-van to the motorized modern tri-wheeler and analyse its performance. There are also scopes of future research to develop more power assisted tri-wheeler in the form of ambulance and cargo hauler. To make it commercially feasible it is important to add extra features in order to make much more user friendly. The extra features are listed below:

Spare wheel compartment: There should be a compartment for at least one extra wheel for the vehicle, for that we have chosen a suitable place, in between the roof top of the vehicle and underneath the PV panel.

Tool box: This vehicle is an On-Road vehicle, for any emergency issues we should keep a tool box in order to avoid unavoidable circumstances which must contain at least

- a Tire-inflator
- Tire lever, Sealer
- Jumper Cables
- Duct-tape,
- Flash-light
- Pliers
- Multi-tool package
- Washer Fluid
- Adjustable-wrench
- An umbrella.

Wind shield: In order to keep the driver away from dust and heavy wind, there must be a wind shield, so that the driver is secured.

Better head light: In case of heavy fog, the lighting system should be improved like installing a High-LED fog lamp.

Easy swapping system for battery: For the sake of the driver, there should be an easy way of swapping batteries from the van to the charging station as mentioned in chapter 6. The system has not implemented yet but in future, the system can be implemented to make the whole system much more user friendly.

Window for air circulation: To avoid suffocation inside the cabin, there must be some windows.

Reverse gear system: Most small vehicle do not require any reverse system, as they have sharp turning radius, for this vehicle the reverse gear system is strongly recommended for future.

Stability issue: The stability issues can be solved using five wheels and by using thick tyres

Lock system: Use strong iron chain to lock the vehicle while parking.

Casing for the Motor controller: In order to avoid from getting drenched and stolen, the motor controller must be covered using a casing

ADVISOR Software: Special simulation software like ADVISOR can be used in future in order to simulate and compare with the practical data obtained.

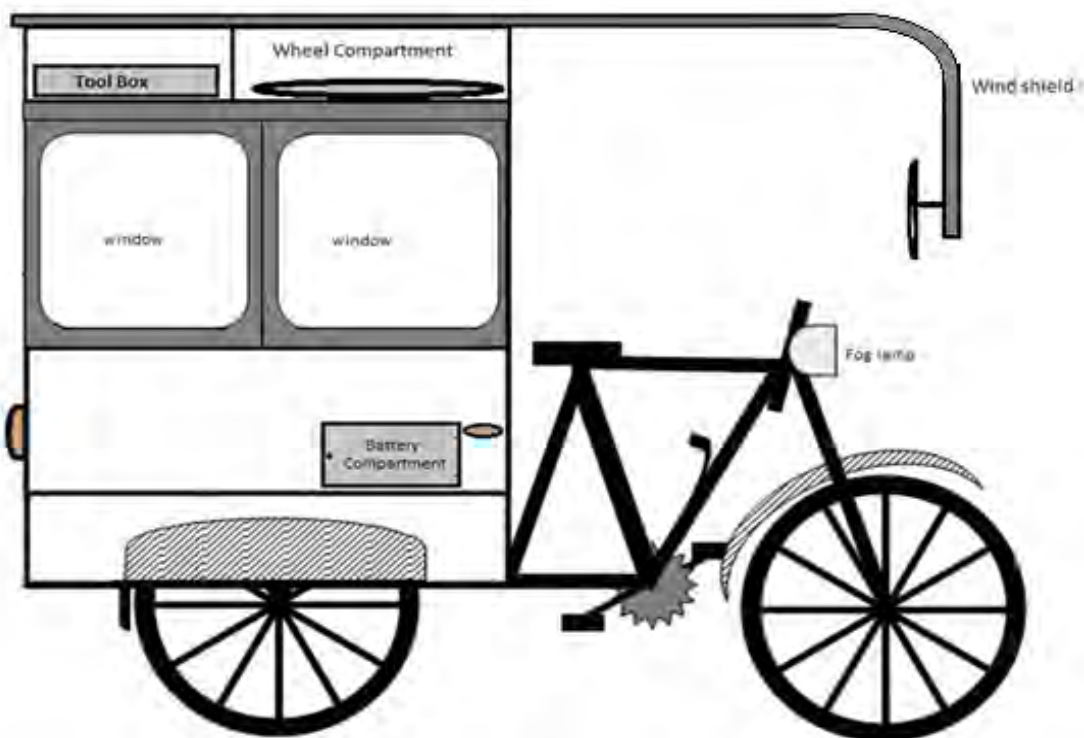

Fig 8.1 Extra features that can be added in future in order to make the system much more feasible and user friendly

REFERENCES

- [1] "We Love Our Bangladesh." : *Rickshaw and Bangladesh from Economic Perspective : One for Another – Why and How*. Web. 18 Aug. 2015.
<<http://weloveourbangladesh.blogspot.se/2013/03/rickshaw-and-bangladesh-from-economic.html>>.
- [2] Strategic Transport Plan, "Strategic Transport Plan for Dhaka- Final Report", Dhaka Transport Co-ordination Board, Dhaka, Bangladesh, 2005.
- [3] We love Our Bangladesh. (n.d.). Retrieved August 16, 2015, from http://weloveourbangladesh.blogspot.com/2012/08/rickshaws-of-bangladesh-and-its-history_7522.html
- [4] Dhaka. (n.d.). Retrieved August 16, 2015. From <http://www.trekearth.com/gallery/Asia/Bangladesh/North/Dhaka/Dhaka/photo1353096.htm>
- [5] 2009 MSU Global Focus Winners Gallery. (n.d.). Retrieved August 16, 2015, from <http://www.isp.msu.edu/awards/photocontest/byyear/2009/photos.php?i=3&x=2>
- [6] T. Wipperman, and T. Sowula, (2007) "The rationalization of non motorized public transport in Bangladesh", 2007. Retrieved August 10, 2009, from <http://www.drishtipat.org/blog/wpcontent/uploads/2007/08/rickshawdevelopment-proposal.pdf>
- [7] S. Begum and B. Sen, "Unsustainable livelihoods, health shocks and urban chronic poverty: Rickshaw pullers as a case study", Chronic Poverty Research Centre, Working Paper 46, 2004. Retrieved May 12, 2009, from http://www.chronicpoverty.org/pubfiles/46Begum_Sen.pdf
- [8] M.M. Ali and M.R. Islam, *Livelihood Status of the Rickshaw Pullers*. Dhaka, Bangladesh: Good Earth, 2005; A. Khaligh and O.C. Onar, *Energy Harvesting: Solar, Wind, and Ocean Energy Conversion Systems*. Boca Raton, FL: CRC Press Inc., 2009.
- [9] R. Gallagher, *The Rickshaws of Bangladesh Dhaka*, Bangladesh; University Press Ltd., 1992
- [10] Beevatech Limited Homepage: <http://www.beevatech.com/index.php>
- [11] M. Asaduzzaman et al., "Power from the sun: An evaluation of institutional effectiveness and impact of solar home systems in Bangladesh," Bangladesh Inst. Dev. Stud. (BIDS), Dhaka Bangladesh, Final Rep. to the World Bank Report, May 30, 2013.
- [12] Rachaen Mahfuz Huq, Numayer Tahmid Shuvo, Partha Chakraborty, Md. Anamul Hoque 'Development of Torque Sensor Based Electrically Assisted Hybrid Rickshaw', 2012.

- [13] http://www.tomcatso.com/upload/20111028/Brushless_DC_electric_tricycle_controller.jpg retrieved June 23, 2012
- [14] Shadman Shabaab Haque, Sabrina Hoque, Sanam Sabnin, Shah Omer Zahid. 'Energy Conservation of Electric Hybrid Rickshaw with PV Support', 2013
- [15] *Wikipedia*. Wikimedia Foundation. Web. 16 Aug. 2015. <https://en.wikipedia.org/wiki/Torque_sensor>.
- [16] "Rotary Torque Sensor." *Torque Sensor*. Web. 16 Aug. 2015. <<https://www.transducertechniques.com/torque-sensor.aspx>>.
- [17] <http://www.appmeas.co.uk/torque-transducers-and-torque-sensors.html> Retrieved August 9, 2015
- [18] Torque sensor operation manual v4.0; Suzhou Victory Sincerity Technology Company Ltd Retrieved
- [19] *Wikipedia*. Wikimedia Foundation. Web. 16 Aug. 2015. <https://en.wikipedia.org/wiki/State_of_charge>.
- [20] <http://www.homepower.com/articles/solar-electricity/equipment-products/managing-your-batteries/page/0/2> Retrieved 10/06/2015

APPENDIX

Appendix A

WIRING DIAGRAM

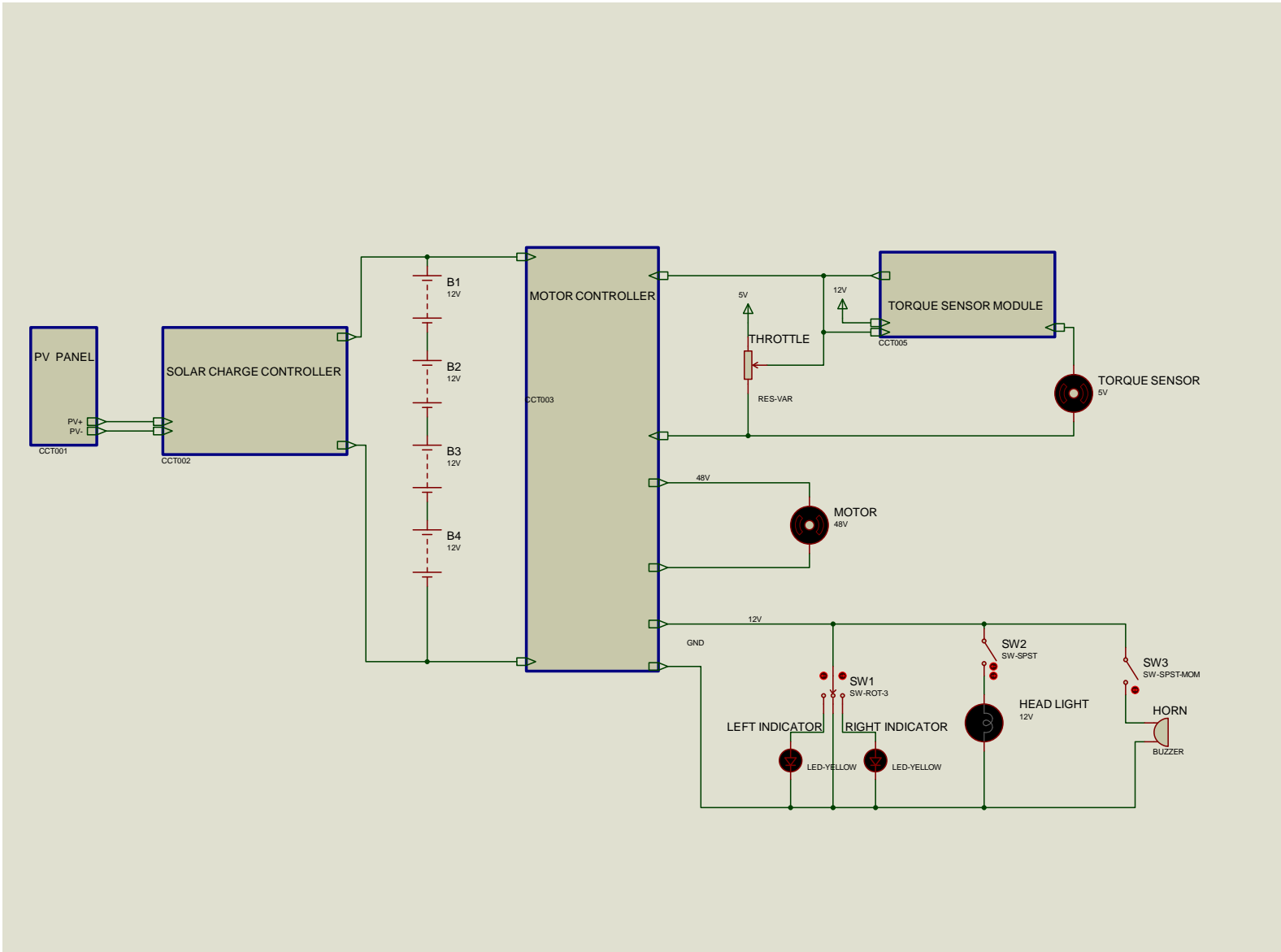

Figure 1 Total System Design

Appendix B

CHRONOLOGICAL DEVELOPMENT OF RICKSHAW

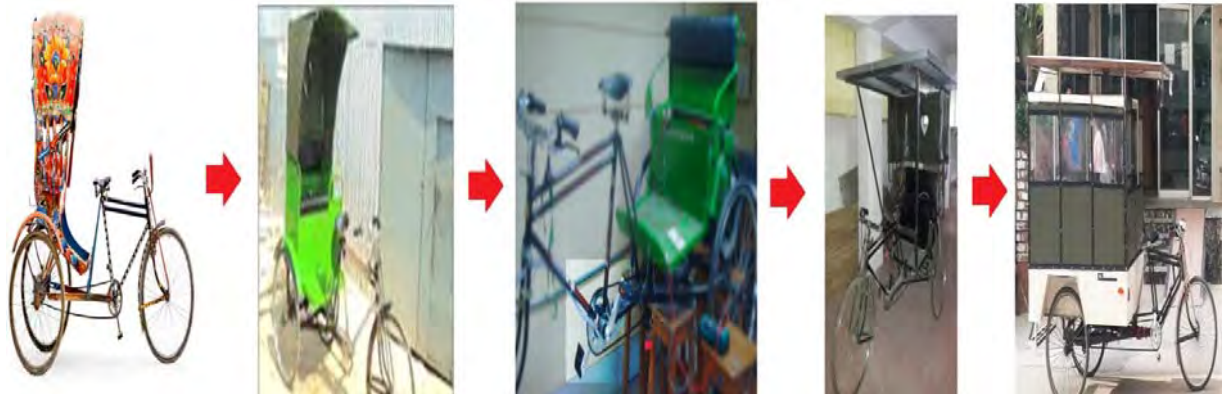

Figure 2 Flow Diagram of Chronological Development of Rickshaw

Appendix C

Table 1: FIELD TEST DATA WITHOUT PV SUPPORT AND TORQUE SENSOR PEDAL

Time (Seconds)	Battery Voltage (V)	Battery Current (A)
0	50.4	1.1
20	49.8	30.1
40	50.2	3.4
60	48.5	6.4
80	49.7	6.4
100	47.7	5.1
120	48.8	2.5
140	50.2	10.4
160	48.5	3.7
180	49.7	2.4
200	49.9	5.1
220	47.7	6.4
240	48.8	4.8
260	49.8	6.9
280	48.8	1.2
300	49.5	6.1
320	49.9	1.1
340	49.9	1.3
360	50.2	33.7
380	48.5	7.8
400	48.3	4.9
420	47.9	8.1
440	49.6	5.2
460	48.2	10.5
480	47.7	12.5
500	49.8	3.5
520	50.1	2.1
540	48.1	6.8
560	47.8	10.9
580	49.3	8.7
600	48.6	5.8
620	49.3	4.7
640	49.6	5.2
660	48.2	10.5
680	47.7	12.5
700	49.8	3.5
720	50.1	2.1
740	49.3	4.7
760	50	29.5
800	48.1	5.5
820	48.1	7.7
840	48.8	2.6

860	47	10.3
880	48.2	7
900	48.4	6.8
920	46.7	17.1
940	48.1	7.7
960	48	9
980	47.7	9.5
1000	49.2	4.4
1020	47	10.3
1040	48.2	7
1060	48.4	6.8
1080	46.7	17.1
1100	47.7	9.5
1120	49.2	4.4
1140	47	10.3
1160	49.6	0.1
1180	47.4	16.3
1200	46.4	23.7
1220	48.8	2.9
1240	48.4	6.1
1260	48.1	18.6
1280	47.9	8.2
1300	48	8.9
1320	47.3	12.1
1340	46.4	23.7
1360	48.8	2.9
1380	48.4	6.1
1400	47.3	12.1
1420	47.4	6.7
1440	47.3	10.1
1460	48.3	5.6
1480	47.2	15.1
1500	47.8	8.3
1520	47.8	9.2
1540	47.6	10
1560	47.6	7.9
1600	48	6.9
1620	48.3	5.6
1640	47.2	13.4
1660	47.8	8.3
1680	48	6.7
1700	48	6.9
1720	46.3	27.4
1740	48.1	5.5
1760	48.2	7.7
1780	46.8	18.5
1800	49.3	4.3
1820	47.8	8.6
1840	49.1	1.8

1860	45.9	13
1880	48.8	10.2
1900	46.7	4.2
1920	48.3	5.6
1940	47.2	13.4
1960	47.8	8.3
1980	48	6.7
1900	48	6.9
1920	46.3	27.4
1940	48.1	5.5
1960	48.8	10.2
1980	46.7	4.2
2000	48.3	5.6
2020	47.9	6.2
2040	47.8	5.5
2060	46.3	32.2
2080	45.3	10
2100	45	20.6
2120	46.2	14.3
2140	45.2	33.2
2160	47.1	10.1
2180	46.4	12.9
2200	44	33.5
2220	47.8	2.3
2240	47.3	3.8
2260	47.7	3.6
2280	47.1	8.4
2300	46.4	9.4
2320	44	33.5
2340	47.8	2.3
2360	47.3	3.8
2380	47.5	5.4
2400	45.5	13.3
2420	46.7	1.5
2440	48.3	9.3
2460	47.1	1.8
2480	43.9	26.5
2500	44	25.7
2520	46.8	1
2540	46.6	2.3
2560	48.4	9
2580	48	4.2
2600	47.3	3.8
2620	47.7	3.6
2640	47.1	8.4
2660	46.4	9.4
2680	44	33.5
2700	47.8	2.3
2720	47.4	6.4
2740	44.1	27.8

2760	43.9	32.9
2780	47.4	6.4
2800	46.9	9
2820	47.5	12.8
2840	46.1	26.6
2860	47.3	9.6
2880	48.3	6.2
2900	48.9	1.4
2920	47.3	4.9
2940	47.6	7.5
2960	45.7	25
2980	48.5	3.8
3000	45.6	23.1
3020	47	17.5
3040	47.3	9.4
3060	46.1	8.5
3080	48.7	10.6
3100	47.3	10.1
3120	48.4	3.9
3140	48	7.2
3160	48.4	3.9
3180	48.5	4.6
3200	47.9	7.2
3220	46.6	22.4
3240	47.8	18.6
3260	47.4	10.4
3280	47.3	6.4
3300	47.3	10.5
3320	47.1	15.3
3340	46.8	16
3360	48.4	4.8
3380	47.1	13.1
3400	48.5	3.8
3420	45.6	23.1
3440	47	17.5
3460	47.3	9.4
3480	46.1	8.5
3500	48.7	10.6
3520	47.3	10.1
3540	48.4	3.9
3560	48.5	4.6
3580	47.9	7.2
3600	46.6	8.9
3620	47.8	11.8
3640	46.3	32.2
3660	45.3	24.3
3680	45	20.6
3700	46.2	17.1
3720	45.2	33.2
3740	47.1	10.1

3760	46.7	1.5
3780	48.3	9.3
3800	47.1	1.8
3820	46.6	10.6
3840	47.1	10.1
3860	48.4	3.9
3880	48.5	4.6
3900	46.7	12.8
3920	45.3	30
3940	47.7	6.4
3960	48.1	5.4
3980	47.2	10.9
4000	47.3	4.9
4020	47.5	12.8
4040	46.1	26.6
4060	47.3	9.6
4080	48.3	6.2
4100	48.9	1.4
4120	47.3	4.9
4140	47.6	7.5
4160	45.7	25
4180	48.5	3.8
4200	45.6	23.1
4220	47	17.5
4240	47.3	9.4
4260	46.1	8.5
4280	48.7	10.6
4300	48.4	3.9
4320	48.5	4.6
4340	46.7	12.8
4360	45.3	30
4380	47.7	6.4
4400	48.1	5.4
4420	47.2	10.9
4440	47.3	4.9
4460	47.5	9.4
4480	46.1	15.1

Appendix D

TABLE 2: FIELD TEST DATA WITH PV SUPPORT ONLY

Time (Seconds)	Panel Voltage (V)	Panel Current (A)	Load Voltage (V)	Load Current (A)	Battery Voltage (A)	Battery Current (A)
5	50.6	1.8	50	5.4	50	3.6
20	49.2	1.7	48.5	3.4	48.5	1.7
40	48.9	1.5	48.3	5.5	48.3	4
60	51.4	1.4	50.1	1.2	50.1	-0.2
80	50.4	2	49.7	5.1	49.7	3.1
100	50.5	2.3	49.9	2.6	49.9	0.3
120	51.4	2.2	50.2	3.1	50.2	0.9
140	48.7	2.2	48.1	8.1	48.1	5.9
160	50.9	2.3	50.3	4.9	50.3	2.6
180	50.3	2	49.8	1.8	49.8	-0.2
200	51.1	2.3	50.5	3.7	50.5	1.4
220	49.5	2.2	49.1	10.1	49.1	7.9
240	48.1	1.9	47.4	11.5	47.4	9.6
260	47.8	1.8	47.1	15.4	47.1	13.6
280	48.9	1.5	47.2	6.8	47.2	5.3
300	50	1.8	49.4	5.4	49.4	3.6
320	50.4	1.9	49.7	2.6	49.7	0.7
340	50.9	1.5	50.3	0.9	50.3	-0.6
360	49.6	1.7	48.9	7.4	48.9	5.7
380	49.3	1.2	48.1	11.7	48.1	10.5
400	48.9	0.9	48.2	17.2	48.2	16.3
420	50	1.8	49.5	1.2	49.5	-0.6
440	50.8	1.3	50.1	1.9	50.1	0.6
460	49.3	1.5	48.7	12.3	48.7	10.8
480	49.3	1.9	48.8	5.5	48.8	3.6
500	49.2	1.7	48.7	9.2	48.7	7.5
520	47.5	1.7	47.1	26.7	47.1	25
540	49.7	1.9	47.5	19.4	47.5	17.5
560	47.5	2	47	16.7	47	14.7
580	50.6	2.3	50.1	14.7	50.1	12.4
600	49.7	2.3	49.2	2.4	49.2	0.1
620	49.7	2.2	49.1	6.7	49.1	4.5
640	50.2	2	49.5	5.8	49.5	3.8
660	49.8	2.1	48.4	8.5	48.4	6.4
680	50.6	2	50	0.7	50	-1.3
700	49.9	1.9	49.4	3.5	49.4	1.6
720	48.3	2.4	47.8	15.1	47.8	12.7
740	46.6	2.1	46.5	29.1	46.5	27

760	50.8	2.1	50.2	2	50.2	-0.1
780	49.1	2.2	48.6	7.1	48.6	4.9
800	49.5	1.9	49.2	8.1	49.2	6.2
820	48.6	1.8	47.1	13.3	47.1	11.5
840	48.6	1.4	48	9.5	48	8.1
860	47.9	1.9	47.4	16.9	47.4	15
880	47.3	1.8	46.6	20.5	46.6	18.7
900	50.5	1.9	49.7	1.7	49.7	-0.2
920	49.6	2	49.1	4.7	49.1	2.7
940	50.5	1.7	49.5	2.8	49.5	1.1
960	48.6	1.5	48.1	10.6	48.1	9.1
980	50.3	1.4	49.9	1.1	49.9	-0.3
1000	47.5	1.6	46.8	10.3	46.8	8.7
1020	46	1.5	45.7	19	45.7	17.5
1040	49.2	1.5	48.6	2.3	48.6	0.8
1060	49.1	1.9	48.5	6.8	48.5	4.9
1080	49	1.9	48.5	8.2	48.5	6.3
1100	50.5	2	49.3	4.9	49.3	2.9
1120	50.7	2.1	50.1	1.2	50.1	-0.9
1140	47.4	2.3	47.2	25.9	47.2	23.6
1160	48	2.3	47.4	15.9	47.4	13.6
1180	50.4	1.8	49.9	1.8	49.9	0
1200	50.1	1.8	49.6	1	49.6	-0.8
1220	49.6	1.7	49	1.1	49	-0.6
1240	49.6	1.5	49.1	4	49.1	2.5
1260	49.4	1.9	49	4.1	49	2.2
1280	50.4	2.3	49.7	1	49.7	-1.3
1300	49.5	1.5	49.3	1.5	49.3	0
1320	49.2	1.2	48.7	7.7	48.7	6.5
1340	50	1.6	49.5	1.5	49.5	-0.1
1360	48.1	2.8	47.3	7.9	47.3	5.1
1380	47	2.5	46.6	25.1	46.6	22.6
1400	47.8	2.5	47.3	12.3	47.3	9.8
1420	50.2	2.1	49.8	0.5	49.8	-1.6
1440	50.2	2.8	49.5	4.7	49.5	1.9
1460	50.1	2.1	49.5	3.9	49.5	1.8
1480	50.3	2	49.5	0.9	49.5	-1.1
1500	49.5	1.8	48.6	7.3	48.6	5.5
1520	49.5	1.9	49.3	4.9	49.3	3
1540	49.5	1.7	49.2	7.7	49.2	6
1560	48.6	1.9	48.1	7.8	48.1	5.9
1580	48.3	2	47.8	9.5	47.8	7.5
1600	50.2	1.5	49.6	1.2	49.6	-0.3
1620	50	1.7	49.7	3.3	49.7	1.6

1640	48.3	1.4	47.8	9.1	47.8	7.7
1660	49.4	1.5	48.8	5.5	48.8	4
1680	49.4	1.2	48.1	5.3	48.1	4.1
1700	50.2	1.6	49.7	0.4	49.7	-1.2
1720	49.6	1.8	48.6	11.7	48.6	9.9
1740	48.7	1.8	46.9	16.7	46.9	14.9
1760	47.8	1.5	47.2	13.4	47.2	11.9
1780	48.6	1	48.1	10.1	48.1	9.1
1800	48.7	1.7	47.9	5.9	47.9	4.2
1820	49.1	1.8	48.5	5.4	48.5	3.6
1840	48.4	1.5	48	7.3	48	5.8
1860	50.4	1.2	49.8	2.7	49.8	1.5
1880	48.6	1	48.1	8.8	48.1	7.8
2000	47.9	1.5	47.4	10.9	47.4	9.4
2020	49.7	1	49.2	1.8	49.2	0.8
2040	48.4	1.8	47.8	8.9	47.8	7.1
2060	50.2	1.4	49.7	5.7	49.7	4.3
2080	48.2	1.9	47.9	9.9	47.9	8
2100	50	1.1	49.5	2.9	49.5	1.8
2120	48.7	1.6	48.2	6.9	48.2	5.3
2140	46.8	1.1	46.2	16.4	46.2	15.3
2160	49.5	1.3	49.2	1.3	49.2	0
2180	48.1	1.9	47.6	10.9	47.6	9
2200	48.8	2.5	48.3	5.7	48.3	3.2
2220	48.7	2	48.2	11.8	48.2	9.8
2240	48	1.9	47.5	11.9	47.5	10
2260	48.4	2.3	48	8.1	48	5.8
2280	47.4	1.2	47.4	16.4	47.4	15.2
2300	48	1	47.6	9.5	47.6	8.5
2320	48.3	0.9	47.8	8.7	47.8	7.8
2340	49	1.4	48.9	4.5	48.9	3.1
2360	48.6	1.4	48	7.5	48	6.1
2380	49.9	1.3	49.3	6.9	49.3	5.6
2400	48.7	1.5	47.9	10.6	47.9	9.1
2420	50	1.8	49.6	3.9	49.6	2.1
2440	48.5	0.8	47.1	14.9	47.1	14.1
2460	48.2	1	46.6	16.9	46.6	15.9
2480	49	1.1	48.7	18.3	48.7	17.2
2500	47.4	1.5	46.9	5.9	46.9	4.4
2520	47.7	1.9	47.2	7.9	47.2	6
2540	49.2	2.4	48.8	7	48.8	4.6
2560	48.9	2.1	47.8	6.1	47.8	4
2580	47.3	1.1	46.9	4.7	46.9	3.6
2600	47.8	1.2	47.2	3.1	47.2	1.9

2620	48.5	1.3	48.2	8.1	48.2	6.8
2640	48.5	1.7	47.9	10.6	47.9	8.9
2660	50.1	1.7	49.5	1	49.5	-0.7
2680	48.1	1.9	47.6	6.7	47.6	4.8
2700	49.8	1.5	49.3	1.3	49.3	-0.2
2720	49.9	1.6	49.4	0.7	49.4	-0.9
2740	47.8	1.5	47.7	11.9	47.7	10.4
2760	47.5	1	47.1	13.5	47.1	12.5
2780	47.7	1.8	47.2	11.4	47.2	9.6
2800	47.5	1	47.1	10.7	47.1	9.7
2820	49.4	1.7	48.4	3.8	48.4	2.1
2840	46.5	2.1	46	15.8	46	13.7
2860	48.1	2	47.6	8.9	47.6	6.9
2880	49.4	2.4	48.5	1.6	48.5	-0.8
3000	45.6	1.8	45	33.1	45	31.3
3020	46.9	0.9	46.1	16.4	46.1	15.5
3040	47.9	1.5	47.5	11.9	47.5	10.4
3060	48.8	1.7	48.2	6.1	48.2	4.4
3080	47.7	2.1	46.7	20.5	46.7	18.4
3100	49.7	2.1	49.2	1	49.2	-1.1
3120	48.3	1.7	47.9	6.4	47.9	4.7
3140	47.6	1.8	47.4	13.1	47.4	11.3
3160	47.8	2	47.4	7.8	47.4	5.8
3180	47.7	1.9	47.1	9.8	47.1	7.9
3200	48.2	1.7	47.8	6.6	47.8	4.9
3220	48.2	1	47.7	8.8	47.7	7.8
3240	48.4	1.8	47.9	6.8	47.9	5
3260	48.2	1.6	47.6	9.8	47.6	8.2
3280	48.5	1.7	48.1	5.6	48.1	3.9
3300	48.3	1.7	47.6	4.7	47.6	3
3320	48.4	2.1	47.7	7.3	47.7	5.2
3340	48	1.7	47.4	10.7	47.4	9
3360	47	1.8	46.4	4.2	46.4	2.4
3380	49.7	2	49	7.4	49	5.4
3400	48.7	1.9	48.2	4.4	48.2	2.5
3420	49.6	1.7	49.1	0.7	49.1	-1
3440	49.2	1.5	48.8	7	48.8	5.5
3460	48.9	1.8	47.8	6.1	47.8	4.3
3480	47.3	1.6	46.9	4.7	46.9	3.1
3500	47.8	1.7	47.2	3.1	47.2	1.4
3520	48.5	1.7	48.2	8.1	48.2	6.4
3540	47.7	1.8	47.2	11.4	47.2	9.6
3560	47.5	1	47.1	10.7	47.1	9.7
3580	49.4	1.7	48.4	3.8	48.4	2.1

3600	46.5	2.1	46	15.8	46	13.7
3620	48.1	2	47.6	8.9	47.6	6.9
3640	49.1	1.8	48.5	6.4	48.5	4.6
3660	48.4	1.5	48	8.3	48	6.8
3680	50.4	1.2	49.8	3.7	49.8	2.5
3700	48.6	1	48.1	9.8	48.1	8.8
3720	47.9	1.5	47.4	11.9	47.4	10.4
3740	49.7	1.4	48.8	5.4	48.8	4
3760	48.8	1.4	48.4	2.2	48.4	0.8
3780	49.5	1.3	49	5.5	49	4.2
3800	49.5	1.5	49.1	2.7	49.1	1.2
3820	50.1	1.8	49.6	1	49.6	-0.8
3840	49.2	0.8	48.8	3.7	48.8	2.9
3860	46.1	1	45.8	28.5	45.8	27.5
3880	47.5	1.1	47.2	7.8	47.2	6.7
3900	48.2	1.5	47.7	6.2	47.7	4.7
3920	48.1	1.9	47.6	7.2	47.6	5.3
3940	47.9	2.4	47.4	3.7	47.4	1.3
3960	47.5	2.1	47	12.5	47	10.4
3980	47.8	1.1	47.3	8.4	47.3	7.3
4000	48	1.2	47.5	7.1	47.5	5.9
4020	47	1.3	46.5	14.1	46.5	12.8
4040	45.8	1.7	45.1	33.8	45.1	32.1
4060	49.3	1.7	48.8	2.1	48.8	0.4
4080	46.5	1.9	45.9	16.3	45.9	14.4
4100	49.2	1.5	48.7	1.8	48.7	0.3
4120	48.4	1.6	48	3.7	48	2.1
4140	49.1	1.4	48.6	1	48.6	-0.4
4160	48.4	1.4	48	3.3	48	1.9
4180	45.9	1.3	45.4	19.8	45.4	18.5
4200	46.5	1.5	46.1	11.4	46.1	9.9
4220	47.2	1.8	47	6.5	47	4.7
4240	48.3	0.8	47.8	4.7	47.8	3.9
4260	46.2	1	45.5	17.4	45.5	16.4
4280	47.6	1.1	47.3	9.9	47.3	8.8
4300	47.8	1.5	47.4	3.5	47.4	2
4320	47.2	1.9	46.7	10.5	46.7	8.6
4340	45.5	2.4	45.1	19.4	45.1	17
4360	45.3	2.1	44.5	33.7	44.5	31.6
4380	49.3	1.1	48.7	4.6	48.7	3.5
4400	49.5	1.2	48.7	2.4	48.7	1.2
4420	49.4	1.3	48.9	5.9	48.9	4.6
4440	48.4	1.7	47.8	7.8	47.8	6.1
4460	47.4	1.7	46.9	15.8	46.9	14.1

4480	48.8	1.9	48.3	1.4	48.3	-0.5
4500	47.9	1.5	47.1	5	47.1	3.5
4520	46.1	1.6	45.6	17.4	45.6	15.8
4540	46.6	1.4	46.1	9.1	46.1	7.7
4560	47.2	1.3	46.7	9.9	46.7	8.6
4580	47.9	1.5	47.4	4.7	47.4	3.2
4600	46.7	1.8	46	11.9	46	10.1
4620	46	0.8	45.6	31	45.6	30.2
4640	44.2	1	43.8	34	43.8	33
4660	45.8	1.5	45.4	15.9	45.4	14.4
4680	46.9	1.5	46.4	11.3	46.4	9.8
4700	47.9	1.9	47.3	6.7	47.3	4.8
4720	49.1	2.4	48.5	3.4	48.5	1
4740	48.8	2.1	47.5	4.7	47.5	2.6
4760	46.3	1.1	46	11.6	46	10.5
4780	44.1	1.2	43.9	14.8	43.9	13.6
4800	45.9	1.3	45.4	11.6	45.4	10.3
4820	48.2	1.7	47.7	4.6	47.7	2.9
4840	47.5	1.7	47	7.6	47	5.9
4860	46.7	1.9	46.4	11.1	46.4	9.2
4880	48.4	1.5	48	3.9	48	2.4
4900	47.5	1.6	47	5.8	47	4.2
4920	48.6	1.6	48.4	3.1	48.4	1.5
4940	48.5	1.7	48.1	4.5	48.1	2.8
4960	47.1	1.4	46.7	8.3	46.7	6.9
4980	45.7	1.7	45.7	15.9	45.7	14.2
5000	48.9	1.4	48.4	1.2	48.4	-0.2
5020	49	1.3	48.4	0.8	48.4	-0.5
5040	47.7	1.5	47.1	10.3	47.1	8.8
5060	48.7	1.8	48.2	2.1	48.2	0.3
5080	47.2	1.8	46.7	5.6	46.7	3.8
5100	48.1	1.9	47.2	8.4	47.2	6.5
5120	47.4	2	46.4	15.4	46.4	13.4
5140	48.1	2.3	47.6	3.2	47.6	0.9
5160	46.7	2.3	46.3	10.5	46.3	8.2
5180	46.1	2.4	45.4	8.7	45.4	6.3
5200	46.6	2.1	46.3	9.7	46.3	7.6
5220	45	1.1	44.5	22.6	44.5	21.5
5240	46.9	1.2	46.6	9.5	46.6	8.3
5260	48.6	1.3	48.1	2.8	48.1	1.5
5280	46.5	1.7	46	11.8	46	10.1
5300	48.6	1.7	48.3	0.6	48.3	-1.1
5320	47.1	1.9	46.4	11.4	46.4	9.5
5340	48.2	1.5	47.6	8.4	47.6	6.9

5360	47.8	1.6	47.2	1.7	47.2	0.1
5380	47.1	1.6	46.8	3.58	46.8	1.98
5400	46.9	1.7	46.1	6.1	46.1	4.4
5420	47	1.4	46.6	3.6	46.6	2.2
5440	46.1	0.9	45.6	11.6	45.6	10.7
5460	48.3	1.4	47.8	8.4	47.8	7
5480	47.9	1.3	46	13.5	46	12.2
5500	46	1.5	45.6	9.3	45.6	7.8
5520	47.5	1.8	47.2	3.5	47.2	1.7
5540	48.3	1.9	47.6	3.8	47.6	1.9
5560	48.5	1.7	48.1	4.2	48.1	2.5
5580	48.6	1.7	48.2	1	48.2	-0.7
5600	47.2	1.8	46.7	7.6	46.7	5.8
5620	48.1	1.8	47.2	9.4	47.2	7.6
5640	47.4	1.8	46.4	15.8	46.4	14
5660	48.1	1.9	47.6	4.2	47.6	2.3
5680	46.7	1.5	46.3	9.5	46.3	8
5700	46.1	1.5	45.4	11.1	45.4	9.6
5720	48.3	1.3	47.8	9.4	47.8	8.1
5740	47.9	1.7	46	10.5	46	8.8
5760	46	1.7	45.6	10.3	45.6	8.6
5780	47.5	1.9	47.2	3.5	47.2	1.6
5800	48.3	1.5	47.6	3.8	47.6	2.3
5820	48.5	1.6	48.1	4.2	48.1	2.6
5840	48.1	1.9	47.2	5.4	47.2	3.5
5860	46.7	1.5	46.4	8.7	46.4	7.2
5880	46.1	1.5	47.6	4.2	47.6	2.7
5900	47	1.4	46.6	2.6	46.6	1.2
5920	46.1	0.9	45.6	11.6	45.6	10.7
5940	48.3	1.4	47.8	8.4	47.8	7
5960	47.9	1.3	46	13.5	46	12.2
5980	46	1.5	45.6	9.3	45.6	7.8
6000	47.5	1.8	47.2	3.5	47.2	1.7
6020	47	1.4	46.6	3.6	46.6	2.2
6040	46.1	0.9	45.6	5.4	45.6	4.5
6060	48.3	1.4	47.8	5.4	47.8	4
6080	47.9	1.3	46	1.3	46	0
6100	46	1.5	45.6	9.3	45.6	7.8

Appendix E

TABLE 3: FIELD TEST DATA WITH TORQUE SENSOR ONLY

Time (seconds)	Torque sensor input to torque adjuster (v)	Torque sensor output to controller unit ()	Battery Voltage (V)	Battery Current (V)
5	0	1.54	49.9	1.8
20	1.03	1.46	50	2.5
40	1.16	1.5	49.7	0.2
60	1.37	1.84	49.5	1.5
80	0.81	1.6	49.5	1.8
100	1.25	1.62	49.6	1.2
120	0	1.55	48.8	8
140	1.5	1.97	47.1	16.2
160	0	1.01	49.8	0.5
180	1.27	1.79	48.9	1.2
200	0	1.68	49.1	1.2
220	1.48	1.9	48.1	1.6
240	0	1.57	49.6	4.5
260	0	1.89	48.1	1.1
280	1.1	1.82	49.1	1.4
300	1.22	1.59	49.7	0.9
320	1.71	2.12	47.3	17.4
340	0	1.72	48.5	7.8
360	1.53	1.9	48.3	9.4
380	1.14	1.44	49.5	0.4
400	1.5	1.94	48.4	9.1
420	0.66	1.33	49.5	0.6
440	1.97	2.28	47	10.5
460	0	1.89	48.6	6.5
480	0.97	1.27	49.5	2.3
500	1.27	1.83	49	1.3
520	0	0.99	49.7	0.1
540	1.17	1.63	49.5	0.3
560	1.59	2.1	48.3	2.4
580	1.51	1.89	47.1	6.7
600	1.15	1.57	49.3	1.8
620	1.68	2.1	48.2	17.2
640	1.8	2.21	46.5	15.7
660	1.7	2.24	47.7	9.1
680	1.32	1.72	49.1	1.3
700	1.69	2.06	48.1	1.3
720	1.61	2.08	48.9	3.36

740	0.72	1.43	50.1	0.9
760	0	1.71	48.9	5.9
780	1.12	1.66	48.9	0.3
800	1.55	1.92	49	1.4
820	1.55	1.8	49.2	1.3
840	1.14	1.53	49.5	0.9
860	1.34	1.69	49.5	0.9
880	2.03	2.62	45.3	30.1
900	1.82	2.41	46.3	16.1
920	1.04	1.81	49.2	0.1
940	1.86	2.32	47.8	10.3
960	1.17	1.63	49.2	0.7
980	1.48	1.93	48.8	2.1
1000	1.81	2.38	49.4	1.2
1020	1.35	2.01	49.3	0.6
1040	1.73	2.14	47.3	9.7
1060	1.7	2.16	46.9	11.1
1080	0	1.01	49.2	0.2
1100	1.77	2.41	45.4	21
1120	0	1.65	49.3	1.6
1140	1.3	1.97	49.3	0.5
1160	0	1.47	49.4	1.2
1180	1.14	1.47	49.2	1.3
1200	0.97	1.25	49.2	0.4
1220	1.32	2.23	47.1	13.3
1240	1.4	2.08	49	1
1260	1.91	2.14	47	11.1
1280	0	1.25	49.5	0.2
1300	1.64	1.88	48.6	2.5
1320	1.89	2.24	47.1	12.5
1340	1.05	1.42	49.1	1.2
1360	1.94	2.47	46.4	22.6
1380	0	1.65	49	2.6
1400	0	1.47	49.3	2.3
1420	0	1.61	48.5	3
1440	1.54	2	49	1.1
1460	1.86	2.41	47.6	4.4
1480	1.84	2.45	46.8	7.8
1500	0.86	1.47	49.1	3.3
1520	1.91	2.32	46.3	20.3
1540	0.89	1.58	49.4	3.5
1560	1.5	1.93	48.8	2.2
1580	1.53	2.12	48.5	1
1600	1.59	1.91	48.8	3

1620	1.42	1.71	49.2	1.5
1640	1.89	2.44	45.9	23.9
1660	0.79	1.24	49	3.1
1680	1.54	2.36	49.1	2.6
1700	0.86	1.57	49.2	3.3
1720	0.91	1.62	49.1	2.9
1740	1.54	2	49	1.1
1760	1.86	2.41	47.6	4.4
1780	1.59	1.91	48.8	3
1800	1.42	1.71	49.2	1.5
1820	1.89	2.44	45.9	23.9
1840	1.13	1.61	48.5	3
1860	1.54	2	49	1.1
1880	1.42	1.71	49.2	1.5
1900	1.86	2.41	47.6	4.4
1920	1.54	2.36	49.1	2.6
1940	1.59	1.91	48.8	3
1960	0.89	1.58	49.4	2.4
1980	0.89	1.58	49.4	3.7
2000	1.84	2.45	46.8	6.5
2020	1.54	2.36	49.1	2.6
2040	0.86	1.57	49.2	3.3
2060	1.91	2.32	46.3	20.3
2080	1.53	2.12	48.5	1
2100	0.79	1.24	49	3.1
2120	1.42	1.71	49.2	1.5
2140	1.86	2.41	47.6	4.4
2160	1.84	2.45	46.8	6.5
2180	1.54	2.36	49.1	2.6
2200	0.86	1.57	49.2	3.3
2220	0.89	1.58	49.4	3.5
2240	0	2.44	45.9	21.9
2260	0.79	1.24	49	3.1
2280	1.54	2.36	49.1	2.6
2300	1.59	1.91	48.8	3
2320	0.89	1.58	49.4	2.4
2340	0.89	1.58	49.4	3.7
2360	1.5	1.93	48.8	2
2380	1.54	2.36	49.1	2.3
2400	0.86	1.57	49.2	3.4
2420	0.79	1.24	49	2.9
2440	1.84	2.45	46.8	5.5
2460	1.97	2.5	45	28.5
2480	1.37	1.75	49.2	1.1

2500	1.68	2.18	48.2	11.4
2520	1.56	1.97	46.4	6.8
2540	1.46	1.74	48.8	1.2
2560	1.43	1.71	49.1	1.1
2580	1.2	1.53	49.1	0.8
2600	1.52	1.81	48.4	5.4
2620	0	2.12	47.5	11.4
2640	1.83	2.32	47	9.4
2660	1.57	1.95	47.9	10.4
2680	1.25	1.56	49	0.3
2700	1.64	2.23	48.1	4.9
2720	1.77	2.01	48.7	2.6
2740	0.95	1.59	48.8	2.1
2760	1.56	1.98	47.8	10.1
2780	1.47	1.85	46.6	15.1
2800	1.52	1.81	48.4	5.4
2820	1.58	2.12	47.5	11.4
2840	1.83	2.32	47	9.4
2860	0	1.95	47.9	10.4
2880	1.37	1.75	49.2	1.1
2900	1.68	2.18	48.2	11.4
2920	1.56	1.97	46.4	6.8
2940	0	1.74	48.8	1.2
2960	1.59	1.91	48.8	3
2980	0.89	1.58	49.4	2.4
3000	0.89	1.58	49.4	3.7
3020	1.5	1.93	48.8	2
3040	1.54	2.36	49.1	2.3
3060	1.64	2.23	48.1	4.9
3080	0	2.01	48.7	2.6
3100	0.95	1.59	48.8	2.1
3120	0.86	1.57	49.2	3.4
3140	0.79	1.24	49	2.9
3160	1.45	1.8	47.7	5.4
3180	1.39	1.79	48.2	2.7
3200	1.83	2.35	47.6	7.2
3220	1.32	1.69	48.1	2.4
3240	1.19	1.56	48.7	1.3
3260	1.69	2.08	48	6.7
3280	1.75	2.24	46.1	18
3300	1.69	2.21	48.1	5.7
3320	0	1.87	48.5	4.7
3340	1.57	1.91	47.2	8.4
3360	1.12	1.47	48.9	0.8

3380	1.79	2.16	48.1	2.4
3400	1.95	2.5	46.1	25.7
3420	1.75	2.4	47.2	15.4
3440	1.45	1.91	47.9	2.9
3460	1.84	2.27	46.9	13.5
3480	1.3	1.7	48.1	5.7
3500	1.2	1.67	48.1	2.9
3520	1.03	1.57	48.7	1.5
3540	1.47	1.86	48.6	2.1
3560	0	1.54	48.1	3.7
3580	1.31	1.69	48.3	1.2
3600	1.6	2.13	47.8	5.4
3620	1.46	2.13	48.1	2.1
3640	0.9	1.19	48.8	0.2
3660	1.72	2.1	47.5	13.4
3680	1.38	1.75	47.1	3.9
3700	1.53	1.97	48.1	2.6
3720	1.63	2.21	48.1	5.1
3740	1.4	1.71	48.4	3.5
3760	0	1.41	48.9	0.8
3780	1.39	1.71	48.5	2.1
3800	1.3	1.64	48.1	3.7
3820	1.43	1.96	48.4	3.3
3840	0	1.96	47.2	7.3
3860	1.23	1.68	48.1	2.2
3880	1.4	1.97	47.2	6.7
3900	0.84	1.12	48.7	0.9
3920	1.38	1.75	47.1	3.9
3940	1.53	1.97	48.1	2.6
3960	1.63	2.21	48.1	5.1
3980	1.4	1.71	48.4	3.5
4000	1.1	1.41	48.9	0.8
4020	1.39	1.71	48.5	2.1
4040	1.47	1.87	48.5	4.7
4060	1.57	1.91	47.2	8.4
4080	1.12	1.47	48.9	0.8
4100	1.79	2.16	48.1	2.4
4120	1.95	2.5	46.1	25.7
4140	1.75	2.4	47.2	15.4
4160	1.6	2.13	47.8	5.4
4180	1.46	2.13	48.1	2.1
4200	0.9	1.19	48.8	0.2
4220	1.72	2.1	47.5	13.4
4240	1.1	1.57	48.3	1.7

4260	1.08	1.55	48.7	0.9
4280	0.9	1.37	48.9	0.7
4300	1.18	1.59	48.7	1.1
4320	1.34	1.7	48.8	0.9
4340	1.69	2.2	47.8	19.8
4360	1.22	1.95	46.8	22.2
4380	1.43	1.75	47.8	5.4
4400	1.1	1.57	48.1	5.7
4420	1.12	1.87	46.4	22.1
4440	1.2	1.57	48.7	3.9
4460	1.88	2.46	44.8	25.9
4480	1.1	1.6	48.1	1.9
4500	1.95	2.48	44.6	31.5
4520	1.19	1.54	48.7	1.1
4540	1.5	1.9	47.6	5.4
4560	0.7	1.04	48.9	0.4
4580	1.3	1.75	48.6	1
4600	1.2	1.57	48	5.6
4620	1.46	1.94	48.6	2.4
4640	1.14	1.36	48.8	1.3
4660	1.88	2.14	47.7	7.1
4680	1.31	1.81	48.4	1.3
4700	1.3	1.5	48.7	2.3
4720	1.8	2.23	46.6	21.9
4740	1.1	1.3	48.8	0.9
4760	1.6	2.07	46.7	15.4
4780	1.1	1.5	48.5	3.8
4800	1.62	2.3	48.3	2.3
4820	1.3	1.7	48.2	2.8
4840	1.2	1.6	48.7	1.7
4860	1.1	1.6	48.8	1.4
4880	1.2	1.47	48.7	3.1
4900	0.97	1.45	48.8	2.9
4920	0.7	0.94	48.9	0.7
4940	0.66	0.94	48.8	0.3
4960	1.57	1.99	47.1	5.9
4980	1.1	1.47	48.4	3.8
5000	1.2	1.66	48.5	1.3
5020	1.08	1.52	47.8	2.5
5040	1.2	1.58	47.4	3.9
5060	0.7	1.01	48.7	0.5
5080	1.3	1.69	46.7	7.9
5100	1.36	1.74	46.1	4.9
5120	1.1	1.63	47.5	1.9

5140	1.5	2.01	47	5.4
5160	1.32	1.79	47.2	4.5
5180	1.45	2	48.5	2.6
5200	0.7	1.07	48.8	0.3
5220	1.1	1.47	48.2	2.1
5240	0.8	1.18	48.5	3.2
5260	1.18	1.59	47.1	5.8
5280	1.23	1.59	48.1	2.1
5300	0	1.86	45.3	18.7
5320	0.71	0.91	48.7	0.5
5340	1.25	1.55	47.2	7.2
5360	1.21	1.62	47.7	4.5
5380	1.4	1.7	46.7	7.9
5400	1.23	1.64	47.4	6.4
5420	0	1.53	47.6	4.3
5440	0	1.5	47.1	5.1
5460	0	1.66	46.9	11.4
5480	0	1.79	46.7	13.3
5500	0	1.55	48	2
5520	0	1.63	47.9	3.9
5540	0	1.69	47.2	7.8
5560	0	1.86	47.3	5
5580	0	1.92	47	8.6
5600	1.8	2.23	46.6	21.9
5620	1.1	1.3	48.8	0.9
5640	1.6	2.07	46.7	15.4
5660	1.1	1.5	48.5	3.8
5680	1.62	2.3	48.3	2.3
5700	1.18	1.59	48.7	1.1
5720	1.34	1.7	48.8	0.9
5740	1.69	2.2	47.8	10
5760	1.22	1.95	46.8	22.2
5780	1.43	1.75	47.8	5.4
5800	1.1	1.57	48.1	5.7
5820	1.12	1.87	46.4	11.4
5840	1.2	1.57	48.7	3.9
5860	1.88	2.46	44.8	25.9
5880	1.21	1.62	47.7	4.5
5900	1.4	1.7	46.7	7.9
5920	1.23	1.64	47.4	6.4
5940	0	1.58	46.1	8.4
5960	1.34	1.72	45.1	15.7
5980	0	1.65	47.1	8.7
6000	0	1.45	48.1	3.2

6020	0	1.3	48.2	0.9
6040	1.18	1.6	48.5	2.3
6060	1.35	1.8	48.3	1.1
6080	1.67	2	47.2	6
6100	1.45	1.8	48	2.1
6120	0	1.8	47.3	5.9
6140	1.11	1.9	47.5	4.5
6160	0	2	47.3	5.5
6180	1.64	2.1	47.5	6.2
6200	1.7	2.1	47	10.1
6220	1.32	1.7	48	1.6
6240	0	1.8	47.8	2
6260	0.65	1	48.4	0.7
6280	0	1.9	47.4	2.6
6300	1.5	1.9	46.3	3.8
6320	1.14	1.5	48.3	0.6
6340	1.21	1.7	47.6	3.3
6360	1.1	1.4	48.2	0.4
6380	0	2	46.7	9.8
6400	1.3	1.6	48	1.2
6420	1.23	1.6	48.2	1.3
6440	1.52	1.92	46.7	12.8
6460	1.34	1.7	48.3	0.8
6480	1.61	2	45.8	14.9
6500	1.52	1.9	47	5.9
6520	1.25	1.6	48.5	1.2
6540	1.23	2	47.4	3.1
6560	0	2	47.3	4.2
6580	1.3	1.8	46.2	8.3
6600	1.09	1.6	48.1	1.4
6620	1.31	1.7	48.1	0.7
6640	1.77	2.22	45	16.7
6660	1.82	1.3	45.9	21.7
6680	1.41	1.88	47.6	2.3
6700	1.46	1.8	48.1	0.6
6720	1.71	2.1	46.8	8.1
6740	1.7	2.1	46.4	3.2
6760	1.7	2	46.6	3
6780	1.43	1.6	48.1	0.1
6800	0	2	46.5	5.5
6820	1.47	1.8	47.8	1.5
6840	1.52	2	47.6	8.2
6860	1.17	1.8	47.3	1.7
6880	0.6	1.1	48.2	0.5

6900	1.73	2.7	43.5	30.4
6920	1.8	2.5	45.8	10.5
6940	1.42	2	47.8	1.2
6960	1.82	2.4	45.5	14
6980	1.69	2	46.1	7
7000	1.92	2.4	47.9	4.8
7020	0	2	46.7	7
7040	1.53	1.9	47.2	1.2
7060	0	1.8	47.9	4.6
7080	1.2	1.78	47.6	1.7
7100	1	1.3	48.2	0.7
7120	1.8	2.2	46	9.7
7140	1.5	1.9	46.9	10
7160	1.55	1.9	47.7	1.8
7180	1.9	2.3	45.7	8.1
7200	0	1.8	47.6	1.5
7220	0.64	1.9	47.1	1.4
7240	1.4	2	47	4.3
7260	0	1.9	47.2	3
7280	1.4	1.7	47	7.3
7300	1.03	1.3	48	0.5
7320	0.85	1.6	47.2	3.5
7340	1.3	2.1	46.3	9
7360	0.83	2.2	48	1.3
7380	1.3	2.1	47.8	2
7400	0	1.5	47	1.3
7420	1.64	1.9	46	5.6
7440	1.36	1.87	47.6	3.9
7460	1.3	1.7	47.1	4
7480	1.18	1.55	47.9	4.1
7500	0	1.8	47.7	1.4
7520	0.7	1.8	47.6	3
7540	1.03	1.3	48.2	0.7
7560	1.98	2.4	44.5	30.1
7580	0.91	1.71	47	4.5
7600	1.65	2.1	45.9	7.8
7620	0	1.7	46.6	6.1
7640	1.3	1.87	47.1	2.6
7660	1.38	1.9	47.6	1.2
7680	1.31	1.7	47.5	1.1
7700	1.3	1.8	46.4	7.9
7720	1.48	1.9	47.5	2.1
7740	0	2.5	47	9.4
7760	0.7	1.2	47.9	0.8

7780	1.91	2.5	43.9	30.1
7800	1.2	1.5	47.9	1.6
7820	1.38	1.9	47.6	1.2
7840	1.31	1.7	47.5	1.1
7860	1.3	1.8	46.4	7.9
7880	0	1.8	47.7	1.4
7900	0.7	1.8	47.6	3
7920	1.03	1.3	48.2	0.7
7940	1.3	2.1	46.3	9
7960	0.83	2.2	48	1.3
7980	1.3	2.1	47.8	2
8000	0	1.5	47	1.3
8020	0.91	1.71	47	4.5
8040	1.65	2.1	45.9	7.8
8060	0	1.7	46.6	6.1
8080	1.3	1.87	47.1	2.6
8100	1.38	1.9	47.6	1.2

Appendix F

TABLE 4: FIELD TEST DATA WITH BOTH PV SUPPORT AND TORQUE SENSOR

Time (seconds)	Torque sensor input to torque adjuster (V)	Torque sensor input to the controller unit (V)	Panel Voltage (V)	Panel Current (V)	Load Voltage (V)	Load Current (A)	Battery Voltage (V)	Battery Current (A)
5	0	2	49.4	4.9	49.1	7.5	49.1	2.6
20	1.2	2.2	49	4.9	48.5	34.9	48.5	30
40	1.4	2.1	50.6	5	50.1	6.5	50.1	1.5
60	1.5	1.1	52	4.7	51.2	0.7	51.2	-4
80	1.5	0.7	52.1	4.7	51.5	0	51.5	-4.7
100	0.7	0.7	52.1	4.9	51.2	0	51.2	-4.9
120	0	2	50.1	4.5	49.9	13.2	49.9	8.7
140	1.5	2.2	49.9	4.5	49.6	23.8	49.6	19.3
160	1.63	1.9	50.5	2.3	50.1	1.6	50.1	-0.7
180	1.69	2.3	48.9	3.5	48.6	28	48.6	24.5
200	1.48	1.8	52	4	51.2	0.8	51.2	-3.2
220	1.77	2.2	51.8	3.5	51.2	2.1	51.2	-1.4
240	1.39	2	49.4	3.7	49	6.8	49	3.1
260	1.61	2	50.2	4.7	49.5	2.7	49.5	-2
280	1.76	0.7	51.2	4.8	51.1	0.2	51.1	-4.6
300	1.64	1	51.2	4.2	51	0.4	51	-3.8
320	0	2	49.2	4.8	48.8	16.6	48.8	11.8
340	0.88	2	48.5	4.8	47.9	17.9	47.9	13.1
360	1.66	1.9	50.8	4.8	49.2	3	49.2	-1.8
380	1.84	0.7	51.1	3.7	51	0.7	51	-3
400	0	1.6	51.3	4.7	51.2	1	51.2	-3.7
420	0.8	2.2	49.5	4.5	49	5.5	49	1
440	1.1	1.8	51.4	4.8	51.2	0.9	51.2	-3.9
460	1.5	2	51.2	5	51	5.8	51	0.8
480	1.5	1.9	50.8	4.5	50.2	2.4	50.2	-2.1
500	1.7	2	50.7	3.8	50	6.9	50	3.1
520	1.77	2.2	51.8	3.5	51.2	2.1	51.2	-1.4
540	1.39	2	49.4	3.7	49	6.8	49	3.1
560	1.69	2.2	48.9	4.5	48	15.3	48	10.8
580	1.68	1.9	51.8	3.8	51.2	1.3	51.2	-2.5
600	1.74	0.78	51.6	4.5	51.2	0.1	51.2	-4.4
620	0.8	2.2	49.5	4.5	49	5.5	49	1
640	1.1	1.8	51.4	4.8	51.2	0.9	51.2	-3.9
660	1.5	2	51.2	5	51	5.8	51	0.8
680	1.5	1.9	50.8	4.5	50.2	2.4	50.2	-2.1

700		2	47.7	4.6	47.2	22.5	47.2	17.9
720		2	49.4	4.9	49.1	7.5	49.1	2.6
740	1.2	2.2	49	4.9	48.5	34.9	48.5	30
760	1.4	2.1	50.6	5	50.1	6.5	50.1	1.5
780	1.5	1.1	52	4.7	51.2	0.7	51.2	-4
800	1.5	0.7	52.1	4.7	51.5	0	51.5	-4.7
820	0.7	0.7	52.1	4.9	51.2	0	51.2	-4.9
840	0	0.78	52.1	5	51.2	0	51.2	-5
860	0	1.3	51.9	5	51.2	0.3	51.2	-4.7
880	0	1.6	51.3	4.7	51.2	1	51.2	-3.7
900	0.8	2.2	49.5	4.5	49	5.5	49	1
920	1.1	1.8	51.4	4.8	51.2	0.9	51.2	-3.9
940	1.5	2	51.2	5	51	5.8	51	0.8
960	1.5	1.9	50.8	4.5	50.2	2.4	50.2	-2.1
980	1.7	2	50.7	3.8	50	6.9	50	3.1
1000	1.4	2.2	50.8	5	49.5	15.8	49.5	10.8
1020	1.7	1.5	51.2	4.6	49.5	34.1	49.5	29.5
1040	1.8	1.4	51.4	4.6	51	0.7	51	-3.9
1060	1.8	0.8	51.6	4.7	51.2	0	51.2	-4.7
1080	0.9	0.8	51.6	4.7	51.2	0	51.2	-4.7
1100	0	1.47	51.2	2.3	50.8	5.4	50.8	3.1
1120	0	0.8	51.4	2.8	51.2	0	51.2	-2.8
1140	1.2	1.9	51.2	3.8	50.7	5.4	50.7	1.6
1160	0	2	50.1	4.5	49.9	13.2	49.9	8.7
1180	1.5	2.2	49.9	4.5	49.6	23.8	49.6	19.3
1200	1.63	1.9	50.5	2.3	50.1	1.6	50.1	-0.7
1220	1.69	2.3	48.9	3.5	48.6	28	48.6	24.5
1240	1.48	1.8	52	4	51.2	0.8	51.2	-3.2
1260	1.77	2.2	51.8	3.5	51.2	2.1	51.2	-1.4
1280	1.39	2	49.4	3.7	49	6.8	49	3.1
1300	1.69	2.2	48.9	4.5	48	15.3	48	10.8
1320	1.68	1.9	51.8	3.8	51.2	1.3	51.2	-2.5
1340	1.74	0.78	51.6	4.5	51.2	0.1	51.2	-4.4
1360	1.63	1.8	52.1	3.7	51.2	0.1	51.2	-3.6
1380	0	0.22	49.2	5	48.9	25.8	48.9	20.8
1400	0	2.1	49.9	5	49.2	4.4	49.2	-0.6
1420	1.85	2.1	49.4	3.8	49.3	12.1	49.3	8.3
1440	1.61	2	50.2	4.7	49.5	2.7	49.5	-2
1460	1.76	0.7	51.2	4.8	51.1	0.2	51.1	-4.6
1480	1.64	1	51.2	4.2	51	0.4	51	-3.8
1500	0	2	49.2	4.8	48.8	16.6	48.8	11.8
1520	0.88	2	48.5	4.8	47.9	17.9	47.9	13.1
1540	1.66	1.9	50.8	4.8	49.2	3	49.2	-1.8
1560	1.84	0.7	51.1	3.7	51	0.7	51	-3
1580	1.58	0	53	3.7	51.2	0.1	51.2	-3.6

1600	0.34	0.8	53.2	1.7	51.2	0.1	51.2	-1.6
1620	0	0.8	53.2	2.1	51.2	0.1	51.2	-2
1640	0	1.9	49.4	3.7	48.8	19.4	48.8	15.7
1660	0	2.2	50.2	3.7	49.3	4.5	49.3	0.8
1680	1.55	2.1	49.7	4.8	49.2	3.9	49.2	-0.9
1700	1.68	2.1	50.3	2.3	49.9	1.1	49.9	-1.2
1720	1.61	2.2	48.4	2.3	48.1	14.4	48.1	12.1
1740	1.4	1.9	51.1	2.3	50.4	6.1	50.4	3.8
1760	1.73	2.5	47.7	4.9	47.1	35	47.1	30.1
1780	1.61	2	50.8	4.8	49.9	3.4	49.9	-1.4
1800	1.88	2.1	48.5	4.9	48.1	17.8	48.1	12.9
1820	1.58	2	50.5	3.7	49.5	4.3	49.5	0.6
1840	1.78	2	49.5	3.7	48.8	5.3	48.8	1.6
1860	1.76	2.1	49.3	2.3	48.8	16.3	48.8	14
1880	1.74	0	52.4	4	51.2	0	51.2	-4
1900	1.78	0.6	52.7	4.7	51.2	0.4	51.2	-4.3
1920	0	2.3	47.8	4.7	47.7	10.8	47.7	6.1
1940	0	2.1	47.8	4.7	47.1	18.4	47.1	13.7
1960	1.86	2.2	48.5	4.7	48.1	13.4	48.1	8.7
1980	1.65	1.9	49.7	4	49.5	3.5	49.5	-0.5
2000	1.69	1.9	50.4	3.7	49.9	2.3	49.9	-1.4
2020	1.65	2	47.7	4	47.2	25.4	47.2	21.4
2040	1.52	1.9	49.8	4	49.7	2.3	49.7	-1.7
2060	1.53	2.1	49.9	4	49.2	1.5	49.2	-2.5
2080	1.47	1.9	50.1	4	49.9	1.4	49.9	-2.6
2100	1.67	2	48.1	4	47.1	8.7	47.1	4.7
2120	1.53	2.2	48.5	3.1	47.8	10.3	47.8	7.2
2140	1.83	1.8	48.9	3.7	48.4	2.9	48.4	-0.8
2160	1.79	0.8	51	3.7	50.9	0	50.9	-3.7
2180	1.45	1.3	51.2	3.7	50.7	0.5	50.7	-3.2
2200	0	2.3	46.6	3.7	45.8	34.9	45.8	31.2
2220	1.11	1.6	50.3	3.7	49	0.4	49	-3.3
2240	1.97	1.7	50.3	3.7	49.8	0.4	49.8	-3.3
2260	1.25	2	49.4	3.7	49.3	15.9	49.3	12.2
2280	1.29	1.3	50.6	3	50.1	0.9	50.1	-2.1
2300	1.64	1.7	49.4	3.7	49.1	6.7	49.1	3
2320	1.04	1.1	50.6	3.7	50.2	0.9	50.2	-2.8
2340	1.4	1.8	51	3.7	50.2	0.3	50.2	-3.4
2360	0.9	0.8	51.8	3.7	51	0.4	51	-3.3
2380	1.32	0.8	52.3	3.7	51.2	0.4	51.2	-3.3
2400	0	0.8	52.7	3.7	51.9	0.4	51.9	-3.3
2420	0	0.8	53	4.1	51.4	0	51.4	-4.1
2440	0	2	49	2.3	48.9	4.5	48.9	2.2
2460	0	1.6	51.1	3.7	50	1.2	50	-2.5
2480	1.6	1.1	50.3	3.7	49.4	1.1	49.4	-2.6

2500	1.1	1.47	49.3	3.7	49	3.7	49	0
2520	0.94	1.4	50.4	3.7	49.9	0.4	49.9	-3.3
2540	1.2	2.5	48.2	3	47.8	12.3	47.8	9.3
2560	0.9	0.9	50.4	2.3	49.9	0.4	49.9	-1.9
2580	1.76	0.8	51.3	2.9	50.5	0.4	50.5	-2.5
2600	0.76	1.6	50.7	3.7	50.1	6.2	50.1	2.5
2620	0	1.5	50.5	4.3	49.8	4.2	49.8	-0.1
2640	1.2	0.8	52.1	4.8	51.5	0	51.5	-4.8
2660	1.2	0.8	52.3	4.9	51.7	0	51.7	-4.9
2680	0	0.8	53.1	4.5	52.2	0	52.2	-4.5
2700	0	0.8	52.3	4.5	52.2	0	52.2	-4.5
2720	0	2.2	48.1	4.5	48	34.7	48	30.2
2740	0	2.1	47.3	4.5	47.8	23.6	47.8	19.1
2760	1.88	2.3	48.9	4.5	49	2.6	49	-1.9
2780	1.56	0.8	52.1	4.5	49.9	0.9	49.9	-3.6
2800	1.65	2.5	46.1	4.5	45.7	23.9	45.7	19.4
2820	0	2	49.5	4.5	48.9	1.2	48.9	-3.3
2840	2	2.2	49.9	4.5	49.2	17.6	49.2	13.1
2860	1.58	2.1	49.9	4.5	49.2	6.5	49.2	2
2880	1.69	1.6	49.9	4	49.4	0.6	49.4	-3.4
2900	1.68	2.2	48.1	4.5	47.7	20	47.7	15.5
2920	1.37	1.8	49.2	4.5	48.3	6.1	48.3	1.6
2940	1.81	2.2	50.2	4.5	48.2	5.4	48.2	0.9
2960	1.2	1.9	49.9	4	49.2	1.3	49.2	-2.7
2980	1.61	2	49.9	4	48.8	2.9	48.8	-1.1
3000	1.57	2	49	4	48.4	2	48.4	-2
3020	1.72	2.4	50.2	4	49.6	16.7	49.6	12.7
3040	1.57	1.47	51	4.5	50.7	0.5	50.7	-4
3060	1.72	0.8	51	4.3	50.5	0	50.5	-4.3
3080	1.3	1.8	50	4.3	49.9	10.3	49.9	6
3100	0	2.3	48.1	4.3	47.6	10.8	47.6	6.5
3120	1.24	2.4	49.2	4.3	47.8	15.6	47.8	11.3
3140	1.74	2.1	46.8	4.3	48	20.5	48	16.2
3160	1.68	0.8	50.3	4.3	49.8	0.9	49.8	-3.4
3180	1.88	1.96	50.7	4.3	50.2	0.2	50.2	-4.1
3200	0	1.9	49.5	4.3	49.1	2.3	49.1	-2
3220	1.3	2	48.8	4.3	48.5	5.4	48.5	1.1
3240	1.43	1.8	50.1	3.5	49.6	0.7	49.6	-2.8
3260	1.43	2.2	47.2	3.5	47.5	10.2	47.5	6.7
3280	1.31	2.2	49.2	3.5	48.7	6.3	48.7	2.8
3300	1.6	2.3	48.9	4.3	48.3	16.4	48.3	12.1
3320	1.69	2	49.4	3	48.8	3.7	48.8	0.7
3340	1.82	2	50.2	4.5	48.9	6.1	48.9	1.6
3360	1.55	2	50.9	4.3	49.2	2.7	49.2	-1.6

3380	1.6	0.7	50	4.3	49.1	0.7	49.1	-3.6
3400	1.43	0.8	50.4	4	50.1	0.5	50.1	-3.5
3420	0	1.5	50.4	1.7	49.7	1.2	49.7	-0.5
3440	0	1.9	50.3	1.9	49.7	1.3	49.7	-0.6
3460	1.2	2.2	49.6	1.9	48.6	9.1	48.6	7.2
3480	1.45	2.1	48.9	1.9	48.7	9.9	48.7	8
3500	1.88	1.9	49.6	2.3	48.4	5.4	48.4	3.1
3520	1.58	2.1	50	2.5	49.2	4.3	49.2	1.8
3540	1.56	1.9	49.3	2.9	49	6.9	49	4
3560	1.68	1.9	50.1	3.5	49.6	1.2	49.6	-2.3
3580	1.61	2.5	46.2	3.5	46.1	36.7	46.1	33.2
3600	1.5	2.1	48.6	3	48.6	12.5	48.6	9.5
3620	2.02	1.8	49.9	3.5	49.5	1.8	49.5	-1.7
3640	1.47	1.8	49.6	3.5	49	3.9	49	0.4
3660	1.44	2.1	48.4	3.5	48.1	9.7	48.1	6.2
3680	1.46	1.9	50	4	49.4	4.4	49.4	0.4
3700	1.66	0.8	51.2	4.5	50.5	1	50.5	-3.5
3720	1.47	0.8	52.2	2.6	51.5	0	51.5	-2.6
3740	0	0.8	52.4	3.2	51.6	0	51.6	-3.2
3760	0	0.7	52.4	3.2	51.6	0	51.6	-3.2
3780	0	1.6	51.1	3.2	50.6	6.1	50.6	2.9
3800	0	2	51.1	3.2	50.4	1.1	50.4	-2.1
3820	1.14	2	49.5	3.2	48.2	2.9	48.2	-0.3
3840	1.52	1.8	49.8	3	49.2	10.7	49.2	7.7
3860	1.52	2	49.5	3	49	2.4	49	-0.6
3880	1.32	2.1	40.1	3	49.4	1.5	49.4	-1.5
3900	1.57	2	48.6	3	48	15.2	48	12.2
3920	1.53	2	49.1	3	49	9.1	49	6.1
3940	1.55	2.1	49.7	3	49.3	5.3	49.3	2.3
3960	1.65	2	49.4	2.5	49.2	0.6	49.2	-1.9
3980	1.67	1.9	49.9	2.5	49.3	1.6	49.3	-0.9
4000	1.42	1.7	49.8	2.5	49.3	2.7	49.3	0.2
4020	1.58	1.9	49.6	2.5	49.5	5.5	49.5	3
4040	1.51	0.8	51.1	2.5	50.4	0.2	50.4	-2.3
4060	1.55	0.8	51.4	3.6	50.7	0.1	50.7	-3.5
4080	0	0.8	51.6	3.6	51	0.1	51	-3.5
4100	0	1.47	51	3.6	50	2.4	50	-1.2
4120	0	1.8	50.6	3.6	49.6	10.3	49.6	6.7
4140	0.9	2.1	49.1	3.6	48	14.7	48	11.1
4160	1.4	1.5	50.3	2.3	49.8	0.6	49.8	-1.7
4180	1.45	2.1	48.6	3.6	48	12.5	48	8.9
4200	1.11	2.1	49.7	3	48.7	6.4	48.7	3.4
4220	1.8	2.1	47.5	3	47.7	18.5	47.7	15.5
4240	1.6	2.1	49.7	3.8	49	5.7	49	1.9
4260	1.58	1.9	48.9	3.8	48.2	2.6	48.2	-1.2

4280	1.58	2.2	48.2	3.8	47.3	21.4	47.3	17.6
4300	1.57	2	49.5	3	48.8	3.9	48.8	0.9
4320	1.66	2.3	47.9	3	47.2	22.1	47.2	19.1
4340	1.56	2	49.9	3	49	2.4	49	-0.6
4360	1.82	2.2	48.5	3	48.1	6.9	48.1	3.9
4380	1.55	0.9	51.1	3	50.6	0.7	50.6	-2.3
4400	1.64	0.8	51.3	3.8	50.8	0	50.8	-3.8
4420	0.74	0.8	51.2	3.5	50.6	0	50.6	-3.5
4440	0	0.8	51.4	0.8	51.5	0.1	51.5	-0.7
4460	0	0.8	51.6	1	51	0.1	51	-0.9
4480	0	1.47	51.3	1	50.6	3.7	50.6	2.7
4500	0	17	50.2	1.2	49.7	2	49.7	0.8
4520	1.1	2	49.4	1.5	49	2.6	49	1.1
4540	1.44	1.95	49	1.5	49.3	3.4	49.3	1.9
4560	1.63	2.07	48.5	1.5	49.1	2.4	49.1	0.9
4580	1.51	2.13	49.7	2.5	49	2.1	49	-0.4
4600	1.41	2.2	47.2	2.9	46.2	17.7	46.2	14.8
4620	1.49	1.69	50	2.9	49.1	5.5	49.1	2.6
4640	1.85	1.29	50.4	2.9	49.8	0.2	49.8	-2.7
4660	1.39	1.9	47.8	2.9	47.2	17.3	47.2	14.4
4680	0.92	1.57	50.1	2.9	49.8	2.1	49.8	-0.8
4700	1.57	1.75	48.6	2.3	48.3	6	48.3	3.7
4720	1.2	1.81	49.8	2.3	48.6	1.2	48.6	-1.1
4740	1.37	2.25	47.9	2.3	47.1	20.4	47.1	18.1
4760	1.38	1.83	49.3	2.3	49.2	3.2	49.2	0.9
4780	1.78	1.86	49	2.3	48.9	1.1	48.9	-1.2
4800	1.49	2.09	49.9	2.3	49.5	1	49.5	-1.3
4820	1.49	1.93	49.4	2	48.2	0.9	48.2	-1.1
4840	1.57	2.25	47.7	2	47	17.7	47	15.7
4860	1.63	2.03	49.1	2	48.5	1.2	48.5	-0.8
4880	1.68	2.29	48.4	3.5	47.6	19.6	47.6	16.1
4900	1.87	1.97	49.9	3.5	48.1	3.1	48.1	-0.4
4920	1.65	2.25	49.5	3.5	49.2	2.1	49.2	-1.4
4940	1.47	1.95	50	2.5	49.7	0.9	49.7	-1.6
4960	1.63	2.01	49.5	2.5	48.8	5.5	48.8	3
4980	1.38	1.2	50.5	1.5	49.9	0.6	49.9	-0.9
5000	1.56	1.01	49.9	1.1	49.3	1.1	49.3	0
5020	0.98	2.15	49.2	1.1	48.6	2.6	48.6	1.5
5040	0.67	2.14	49.4	1.1	48.7	2.6	48.7	1.5
5060	1.52	1.91	48.4	1.1	48	3.6	48	2.5
5080	1.51	2.19	48	1.1	47.8	2.9	47.8	1.8
5100	1.46	2.28	48.5	1.5	48.2	12.4	48.2	10.9
5120	1.67	2.2	49.5	1.5	48.4	10.9	48.4	9.4
5140	1.57	1.95	49.7	3.9	48.5	2.4	48.5	-1.5
5160	1.67	2	49	3.9	48.6	5.7	48.6	1.8

5180	1.57	2	49.9	3.5	48.9	8.6	48.9	5.1
5200	1.7	2.14	49	2.5	47.9	10.9	47.9	8.4
5220	1.71	2.13	48.9	2.5	48.4	4.2	48.4	1.7
5240	1.59	0.8	49.6	2.5	49.1	0.3	49.1	-2.2
5260	1.62	2.18	47.8	2.5	47	7.6	47	5.1
5280	0	0.8	50.1	2.4	49.6	0.7	49.6	-1.7
5300	1.65	2.1	48	2.4	47.7	20.6	47.7	18.2
5320	0	2.13	47.1	2.4	46.6	15	46.6	12.6
5340	1.87	2.11	49.1	2.4	48.2	2.7	48.2	0.3
5360	1.77	2.14	47.6	2.4	46.9	15.1	46.9	12.7
5380	1.71	2.08	49.9	2.4	49	1.4	49	-1
5400	1.76	1.89	49.6	2.4	48.7	2.8	48.7	0.4
5420	1.48	2.18	48.9	2.4	47.9	5.7	47.9	3.3
5440	1.55	2.29	47.9	3.5	47.4	19.5	47.4	16
5460	1.57	1.94	48.8	3.5	49.2	0.9	49.2	-2.6
5480	1.88	2.07	49.2	3.5	48.2	3.3	48.2	-0.2
5500	1.64	2.26	49.4	3.5	48.4	3.1	48.4	-0.4
5520	1.51	1.22	50.5	3.5	50	3.1	50	-0.4
5540	1.59	1.03	50.9	3.5	50.3	0.3	50.3	-3.2
5560	0.95	0.79	51	2.1	50.4	0.1	50.4	-2
5580	0.6	1.85	48.4	2.1	48.1	22.1	48.1	20
5600	0	2.13	50	2.1	49	3.5	49	1.4
5620	1.57	2.21	49.5	2.1	48.8	3.4	48.8	1.3
5640	1.61	2.13	47.1	1	48.9	2.3	48.9	1.3
5660	1.51	1.85	50.5	1.5	49.9	0.5	49.9	-1
5680	1.56	2.12	49.1	1.5	48.5	7.2	48.5	5.7
5700	1.31	2.02	48.6	1.5	48.4	1.1	48.4	-0.4
5720	1.49	2.12	49.5	1.5	48.8	2.6	48.8	1.1
5740	1.48	0.79	50.5	1.5	49.6	0.8	49.6	-0.7
5760	1.66	0.79	50.1	0.9	50.1	9.6	50.1	8.7
5780	0	0.79	50.1	0.9	49.6	0.1	49.6	-0.8
5800	0	0.79	50.1	1.5	49.7	0.2	49.7	-1.3
5820	0	0.79	50.1	1.5	49.7	0.2	49.7	-1.3
5840	0	0.79	50.1	1.1	49.7	0.2	49.7	-0.9
5860	0	0.8	50.1	0.5	49.7	0.1	49.7	-0.4
5880	0	1.72	47.8	1.1	47.4	15.5	47.4	14.4
5900	0	2.03	49.1	1.5	48.1	6.5	48.1	5
5920	0	0.84	50	1.5	49.4	1.1	49.4	-0.4
5940	1.55	1.67	50.5	2	49.5	0.4	49.5	-1.6
5960	0	2	49.1	2	48.4	2.4	48.4	0.4
5980	1.37	2.11	49.9	2.5	49.4	0.5	49.4	-2
6000	1.59	2.09	49.6	1.5	48.8	7.8	48.8	6.3
6020	1.54	2.93	49	1.5	48.8	0.9	48.8	-0.6
6040	1.7	1.29	50.1	1.5	49.4	2.6	49.4	1.1
6060	1.49	2.04	49.6	0.9	49.1	0.4	49.1	-0.5

6080	0.73	2.12	49.4	1	48	13.5	48	12.5
6100	1.58	2.12	49.4	2.5	48.2	16.8	48.2	14.3
6120	1.65	2.23	48.9	0.5	48.4	8.5	48.4	8
6140	1.64	2.02	49.1	0.9	48.4	5.6	48.4	4.7
6160	1.74	2.25	49.4	1.5	48.2	11.9	48.2	10.4
6180	1.57	0.86	50.1	0.9	49.7	1.1	49.7	0.2
6200	1.74	0.96	50.1	0.9	49.7	1.5	49.7	0.6
6220	0	0.85	50.6	2	50	0.1	50	-1.9
6240	0.68	1.32	49.8	2	49.4	0.3	49.4	-1.7
6260	0	1.6	49.9	1.7	49.5	0.7	49.5	-1
6280	0.54	2.08	48.5	1.1	48.1	2.3	48.1	1.2
6300	1.35	1.94	49.1	1.4	48.5	11.3	48.5	9.9
6320	1.54	2.2	49.3	1.1	48.5	1.7	48.5	0.6
6340	1.54	2.14	48.1	1.1	47.9	13.9	47.9	12.8
6360	1.49	2.1	48.9	0.9	48.6	5.1	48.6	4.2
6380	1.71	2.1	48.1	1.1	47.9	13.5	47.9	12.4
6400	1.55	2.21	48.3	2.5	47.7	15.6	47.7	13.1
6420	1.62	1.8	49.8	2.9	49.1	2.4	49.1	-0.5
6440	1.62	2.18	48.6	2.4	48.2	9.1	48.2	6.7
6460	1.57	2.02	49.1	2.9	48.7	1.6	48.7	-1.3
6480	1.53	2.2	48.2	2.9	47.1	12	47.1	9.1
6500	1.44	1.99	48.7	1.5	48.1	7.8	48.1	6.3
6520	1.64	0.87	50.1	1.5	49.5	0.2	49.5	-1.3
6540	1.61	0.85	50	1.5	49.5	0.2	49.5	-1.3
6560	0	0.8	50.1	0.5	49.5	0.4	49.5	-0.1
6580	0	2.15	47.9	1.1	46.9	19.3	46.9	18.2
6600	0	2.1	49.3	1.6	48.2	2.6	48.2	1
6620	1.8	1.98	49.1	1.1	48.7	1.2	48.7	0.1
6640	1.73	1.9	48.6	0.9	48.2	5.7	48.2	4.8
6660	1.44	2.12	45.7	1.4	45.5	30.5	45.5	29.1
6680	1.5	2.19	48.4	1.6	48.3	9.8	48.3	8.2
6700	1.63	2.2	48.6	1.2	47.5	18.6	47.5	17.4
6720	1.71	2.09	48.6	2.1	48.2	9.5	48.2	7.4
6740	1.65	1.31	50.1	2.5	49.3	0.6	49.3	-1.9
6760	1.59	2.16	48.6	1.5	47.9	2.9	47.9	1.4
6780	0.97	2.25	48.7	1.9	47.8	14.3	47.8	12.4
6800	1.7	2.13	48.6	2.3	48.4	6.8	48.4	4.5
6820	1.7	2.1	48.4	1.9	48.5	7.5	48.5	5.6
6840	1.64	1.98	49.1	1.1	48.7	1.2	48.7	0.1
6860	1.57	1.9	48.6	0.9	48.2	5.7	48.2	4.8
6880	1.44	2.18	49.6	0.6	49.2	2.1	49.2	1.5
6900	1.5	2.12	49.3	1.8	48.6	6.5	48.6	4.7
6920	1.74	2.16	48.1	0.9	47.8	8.6	47.8	7.7
6940	1.56	2.02	49.2	1.1	48.4	1	48.4	-0.1
6960	1.74	2.12	49.4	2.5	48.5	1.6	48.5	-0.9

6980	1.49	1.96	49.6	1.5	48.4	0.6	48.4	-0.9
7000	1.64	2.08	49.1	0.8	48.9	2.1	48.9	1.3
7020	1.48	2	49.7	3.5	49	0.9	49	-2.6
7040	1.63	2.12	48.9	1.5	48.4	1.7	48.4	0.2
7060	1.51	2.09	48.7	1.9	48	6.1	48	4.2
7080	1.52	2.13	49.1	2.3	48.5	10.3	48.5	8
7100	1.65	2.22	47.5	1.1	47.5	6.8	47.5	5.7
7120	1.61	1.3	49.8	1.3	49.3	1.9	49.3	0.6
7140	1.73	0.82	49.9	1.3	49.4	0.6	49.4	-0.7
7160	0.98	1.72	49	2.5	48.3	11.4	48.3	8.9
7180	0	2.22	47.2	1.5	46.6	15.7	46.6	14.2
7200	1.2	2.34	47.9	1.9	47.5	12.1	47.5	10.2
7220	1.78	1.93	48.9	1.1	48.3	3.4	48.3	2.3
7240	1.8	2.16	49.5	1.9	48.7	1.5	48.7	-0.4
7260	1.46	2.12	48.7	3.4	48.2	4.7	48.2	1.3
7280	1.69	1.96	49.7	3.9	48.6	3.5	48.6	-0.4
7300	1.67	2.18	48.3	1.9	47.7	21.3	47.7	19.4
7320	1.62	2.05	49.1	2.9	48.1	3.2	48.1	0.3
7340	1.8	2.16	49.5	1.9	48.7	1.5	48.7	-0.4
7360	1.7	2	49.7	3.5	49	0.9	49	-2.6
7380	1.69	2.02	49.2	1.1	48.4	1	48.4	-0.1
7400	1.51	2.12	49.4	2.5	48.5	1.6	48.5	-0.9
7420	1.49	1.66	48.9	1.5	48.7	0.5	48.7	-1
7440	1.64	2.16	48.7	0.9	48.2	2.5	48.2	1.6
7460	1.12	2.04	49.3	1.5	49	1.1	49	-0.4
7480	1.66	2.14	46.6	2.2	46.6	30	46.6	27.8
7500	1.66	2.26	46.6	3.5	46.1	17.8	46.1	14.3
7520	1.81	2.1	47.3	1.6	47.1	4.5	47.1	2.9
7540	1.82	2.14	49	3.3	47.6	4.3	47.6	1
7560	1.72	2.12	48.2	3.6	47.2	5.1	47.2	1.5
7580	1.67	1.92	49.4	3.1	48.4	1.8	48.4	-1.3
7600	1.6	2.14	48.8	2.6	48.2	3.5	48.2	0.9
7620	1.52	2.14	48.5	3.3	47.8	3.8	47.8	0.5
7640	1.54	2.16	49.1	2.8	48.5	2.1	48.5	-0.7
7660	1.66	1.82	49.1	2.1	48.1	1.6	48.1	-0.5
7680	1.64	2.02	49.2	1.1	48.4	1	48.4	-0.1
7700	1.4	2.14	49	3.3	47.6	4.3	47.6	1
7720	1.49	1.92	49.4	3.1	48.4	1.8	48.4	-1.3
7740	1.67	2.16	48.7	0.9	48.2	2.5	48.2	1.6
7760	1.52	2.04	49.3	1.5	49	1.1	49	-0.4
7780	1.66	2.14	46.6	2.2	46.6	30	46.6	27.8
7800	1.66	2.18	48.3	1.9	47.7	19.8	47.7	17.9
7820	1.81	2.05	49.1	2.9	48.1	3.2	48.1	0.3
7840	1.8	2.16	49.5	1.9	48.7	1.5	48.7	-0.4
7860	1.7	2	49.7	3.5	49	2.1	49	-1.4

7880	1.69	2.26	46.6	3.5	46.1	17.8	46.1	14.3
7900	1.51	2.1	47.3	1.6	47.1	4.5	47.1	2.9
7920	1.82	2.05	49.1	2.9	48.1	3.2	48.1	0.3
7940	1.72	2.16	49.5	1.9	48.7	1.5	48.7	-0.4
7960	1.7	2.3	46.6	3.5	46.1	17.8	46.1	14.3
7980	1.69	2.13	47.4	2.1	47.9	9.2	47.9	7.1
8000	1.79	1.9	48.7	1.2	47.9	3.5	47.9	2.3
8020	1.9	1.47	49.8	3.5	49	5.2	49	1.7
8040	1.58	2.16	47.9	1.9	47.2	10.5	47.2	8.6
8060	1.27	1.31	49.7	1.5	48.4	5.3	48.4	3.8
8080	1.73	2.18	49.6	3.5	48.2	2.4	48.2	-1.1
8100	0.96	2.1	46.9	2.2	46.7	10.6	46.7	8.4
8120	1.57	1.92	48.6	3.2	47.9	4.3	47.9	1.1
8140	1.71	2.06	47.6	1.1	47.1	1.5	47.1	0.4
8160	1.48	1.9	48.7	0.9	47.9	1.2	47.9	0.3
8180	1.64	0.79	49.4	1.5	48.9	5.3	48.9	3.8
8200	1.5	0.89	49.6	1.5	49.1	0.5	49.1	-1
8220	0	1.89	48.2	2.6	47.7	7.9	47.7	5.3
8240	0	1.96	48.1	3.3	47.5	9.1	47.5	5.8
8260	1.52	2.05	48	1.9	47.5	7.7	47.5	5.8
8280	1.54	2.18	47.8	3.5	47.1	13.8	47.1	10.3
8300	1.56	1.94	47.2	2.2	47.4	7.9	47.4	5.7
8320	1.76	1.97	47.7	2.6	47.1	3.9	47.1	1.3
8340	1.5	1.91	48.2	1.1	47.4	7	47.4	5.9
8360	1.5	1.87	48.1	1.6	47.4	8.5	47.4	6.9
8380	1.6	1.92	48.4	1.1	47.8	5.7	47.8	4.6
8400	1.56	2.07	48.3	1.5	46.5	13.4	46.5	11.9
8420	1.69	1.94	48.1	1.3	47.7	8.7	47.7	7.4
8440	1.7	1.65	48.2	1.1	47.8	7	47.8	5.9
8460	1.67	1.97	47.7	2.6	47.1	3.9	47.1	1.3
8480	1.32	1.91	48.2	1.1	47.4	7	47.4	5.9
8500	1.5	1.87	48.1	1.6	47.4	8.5	47.4	6.9
8520	1.6	1.92	48.4	1.1	47.8	5.7	47.8	4.6
8540	1.56	2.18	49.6	3.5	48.2	2.4	48.2	-1.1
8560	1.69	2.1	46.9	2.2	46.7	10.6	46.7	8.4
8580	1.57	1.92	48.6	3.2	47.9	4.3	47.9	1.1
8600	1.71	1.96	48.1	3.3	47.5	9.1	47.5	5.8
8620	1.48	2.05	48	1.9	47.5	7.7	47.5	5.8
8640	1.54	2.18	47.8	3.5	47.1	13.8	47.1	10.3
8660	1.56	2.16	49.5	1.9	48.7	1.5	48.7	-0.4
8680	1.76	2	49.7	3.5	49	2.1	49	-1.4
8700	1.69	2.26	46.6	3.5	46.1	17.8	46.1	14.3
8720	1.51	2.1	47.3	1.6	47.1	4.5	47.1	2.9
8740	1.82	0.78	49.6	1.1	49.2	0.3	49.2	-0.8
8760	1.72	1.51	49.4	1.6	48.8	0.9	48.8	-0.7

8780	0	2.1	48.2	0.9	48.2	5.9	48.2	5
8800	1.27	2.16	48.6	0.5	47.5	4.4	47.5	3.9
8820	1.59	2.19	48.3	1.3	47.8	6	47.8	4.7
8840	1.7	1.98	48.9	1.2	48.1	2.6	48.1	1.4
8860	1.67	2.08	48.2	2.3	48.1	10.6	48.1	8.3
8880	1.45	2.17	48.6	2.1	47.6	5.5	47.6	3.4
8900	1.71	2.02	48.6	1.5	48.1	3.2	48.1	1.7
8920	1.51	2.09	48.2	1.6	47.9	1.9	47.9	0.3
8940	1.47	2.19	47.9	2.1	48	3.4	48	1.3
8960	1.5	2.11	48.3	1.3	48.2	2.8	48.2	1.5
8980	1.68	2.11	48.5	0.9	47.9	5	47.9	4.1
9000	1.68	2.24	47.9	1.1	47.9	9.4	47.9	8.3
9020	1.78	2.3	47.4	1.9	47.4	19.5	47.4	17.6
9040	1.67	1.05	49.2	1.1	48.7	0.63	48.7	-0.47
9060	1.71	2.09	48.2	1.6	47.9	1.9	47.9	0.3
9080	0.8	2.19	47.9	2.1	48	3.4	48	1.3
9100	1.5	2.11	48.3	1.3	48.2	2.8	48.2	1.5
9120	1.68	2.11	48.5	0.9	47.9	5	47.9	4.1
9140	1.68	2.05	48	1.9	47.5	7.7	47.5	5.8
9160	1.78	2.18	47.8	3.5	47.1	13.8	47.1	10.3
9180	1.56	2.16	49.5	1.9	48.7	1.5	48.7	-0.4
9200	1.76	2.1	48.2	0.9	48.2	5.9	48.2	5
9220	1.69	2.16	48.6	0.5	47.5	4.4	47.5	3.9
9240	1.59	2.19	48.3	1.3	47.8	6	47.8	4.7
9260	1.7	1.98	48.9	1.2	48.1	2.6	48.1	1.4
9280	1.67	1.91	48.2	1.1	47.4	7	47.4	5.9
9300	1.45	1.87	48.1	1.6	47.4	8.5	47.4	6.9
9320	1.6	1.92	48.4	1.1	47.8	5.7	47.8	4.6
9340	1.56	2.18	49.6	3.5	48.2	2.4	48.2	-1.1
9360	1.69	2.25	48	1.2	47.8	4.3	47.8	3.1
9380	1.57	2.1	48	2.2	47.2	4.7	47.2	2.5
9400	1.75	2.26	47.4	2.1	47.3	15.3	47.3	13.2
9420	1.62	2.25	47.5	1.8	47.6	12.2	47.6	10.4
9440	1.76	2.26	48.2	3.5	47.6	6.1	47.6	2.6
9460	1.68	2.11	47.9	3.2	47.5	12.2	47.5	9
9480	1.73	2.07	48.4	1.9	47.5	1.7	47.5	-0.2
9500	1.6	2.11	47.8	1.4	47.1	1.9	47.1	0.5
9520	1.52	2	48.4	1.4	47.8	2.7	47.8	1.3
9540	1.71	1.91	48.5	1.4	48.1	0.7	48.1	-0.7
9560	1.51	1.3	48.9	1.9	48.4	0.6	48.4	-1.3
9580	1.52	0.82	48.9	1.2	48.2	0.3	48.2	-0.9
9600	0.67	2.25	47.5	1.8	47.6	12.2	47.6	10.4
9620	0	2.26	48.2	3.5	47.6	6.1	47.6	2.6
9640	1.68	2.11	47.9	3.2	47.5	12.2	47.5	9
9660	1.73	2.07	48.4	1.9	47.5	1.7	47.5	-0.2

9680	1.6	1.91	48.2	1.1	47.4	7	47.4	5.9
9700	1.52	1.87	48.1	1.6	47.4	8.5	47.4	6.9
9720	1.6	1.92	48.4	1.1	47.8	5.7	47.8	4.6
9740	1.56	2.11	47.8	1.4	47.1	1.9	47.1	0.5
9760	1.69	2	48.4	1.4	47.8	2.7	47.8	1.3
9780	1.71	1.91	48.5	1.4	48.1	0.7	48.1	-0.7
9800	1.51	2.11	48.3	1.3	48.2	2.8	48.2	1.5
9820	1.52	2.11	48.5	0.9	47.9	5	47.9	4.1
9840	1.68	2.05	48	1.9	47.5	7.7	47.5	5.8
9860	1.78	2.25	48	1.2	47.8	4.3	47.8	3.1
9880	1.56	2.1	48	2.2	47.2	4.7	47.2	2.5
9900	1.75	0.82	48.9	1.2	48.2	0.3	48.2	-0.9
9920	1.62	2.27	46.4	1.5	45.8	19.2	45.8	17.7
9940	1.7	2.25	46.9	1.8	46.5	14.2	46.5	12.4
9960	1.74	2.1	48.4	2.1	47.8	1.2	47.8	-0.9
9980	1.79	2.32	47.5	2.9	46.8	8.1	46.8	5.2
10000	1.91	2.16	47.6	0.9	47.6	1.9	47.6	1
10020	1.37	1.87	48.8	2.6	48.2	1.1	48.2	-1.5
10040	1.54	1.98	48.1	2.3	47.6	1.2	47.6	-1.1
10060	1.49	1.69	48.5	1.1	47.8	1.4	47.8	0.3
10080	1.87	2.15	47.9	2.1	46.5	8.7	46.5	6.6
10100	1.57	2.09	48.1	1.1	47.9	1.3	47.9	0.2
10120	1.63	2.02	48.5	1.6	47.9	0.7	47.9	-0.9
10140	1.51	2.06	48.4	1.9	47.6	0.8	47.6	-1.1
10160	1.61	2.17	48.3	2.2	47.6	6.5	47.6	4.3
10180	1.54	1.98	48.1	2.3	47.6	1.2	47.6	-1.1
10200	1.49	1.69	48.5	1.1	47.8	1.4	47.8	0.3
10220	1.51	2.11	48.3	1.3	48.2	2.8	48.2	1.5
10240	1.52	2.11	48.5	0.9	47.9	5	47.9	4.1
10260	1.68	2.05	48	1.9	47.5	7.7	47.5	5.8
10280	1.79	2.32	47.5	2.9	46.8	15	46.8	12.1
10300	1.91	2.16	47.6	0.9	47.6	1.9	47.6	1
10320	1.37	1.87	48.8	2.6	48.2	1.1	48.2	-1.5
10340	1.68	2.11	47.9	3.2	47.5	12.2	47.5	9
10360	1.73	2.07	48.4	1.9	47.5	1.7	47.5	-0.2
10380	1.6	1.91	48.2	1.1	47.4	7	47.4	5.9
10400	1.52	1.87	48.1	1.6	47.4	8.5	47.4	6.9
10420	1.68	2.05	48	1.9	47.5	7.7	47.5	5.8
10440	1.78	2.25	48	1.2	47.8	4.3	47.8	3.1
10460	1.56	2.1	48	2.2	47.2	4.7	47.2	2.5
10480	1.69	2.26	46.6	3.5	46.1	17.8	46.1	14.3
10500	1.51	2.1	47.3	1.6	47.1	4.5	47.1	2.9
10520	1.63	2.02	48.5	1.6	47.9	0.7	47.9	-0.9
10540	1.51	2.06	48.4	1.9	47.6	0.8	47.6	-1.1
10560	1.61	2.17	48.3	2.2	47.6	6.5	47.6	4.3

10580	1.6	1.91	48.2	1.1	47.4	7	47.4	5.9
10600	1.52	1.87	48.1	1.6	47.4	8.5	47.4	6.9
10620	1.68	2.05	48	1.9	47.5	10.7	47.5	8.8
10640	1.78	2.25	48	1.2	47.8	4.3	47.8	3.1
10660	1.56	2.1	48	2.2	47.2	2.6	47.2	0.4
10680	1.57	2.09	48.1	1.1	47.9	1.3	47.9	0.2
10700	1.63	2.02	48.5	1.6	47.9	0.7	47.9	-0.9
10720	1.51	2.06	48.4	1.9	47.6	0.8	47.6	-1.1
10740	1.7	2.25	46.9	1.8	46.5	14.2	46.5	12.4
10760	1.74	2.1	48.4	2.1	47.8	1.2	47.8	-0.9
10780	1.79	2.32	47.5	2.9	46.8	8.1	46.8	5.2
10800	1.91	2.16	47.6	0.9	47.6	3.9	47.6	3
10820	1.56	2.1	48	2.2	47.2	5.6	47.2	3.4
10840	1.57	2.09	48.1	1.1	47.9	1.3	47.9	0.2
10860	1.63	2.02	48.5	1.6	47.9	0.7	47.9	-0.9
10880	1.51	2.06	48.4	1.9	47.6	0.8	47.6	-1.1
10900	0	2.26	48.2	3.5	47.6	6.1	47.6	2.6
10920	1.68	2.11	47.9	3.2	47.5	15.8	47.5	12.6
10940	1.73	2.07	48.4	1.9	47.5	10.8	47.5	8.9
10960	1.6	1.91	48.2	1.1	47.4	11.1	47.4	10
10980	1.52	1.87	48.1	1.6	47.4	2.6	47.4	1
11000	1.6	1.92	48.4	1.1	47.8	5.7	47.8	4.6
11020	1.56	2.11	47.8	1.4	47.1	1.9	47.1	0.5
11040	1.69	2	48.4	1.3	47.8	0.9	47.8	-0.4
11060	1.71	1.91	48.5	1.4	48.1	0.7	48.1	-0.7
11080	1.51	2.11	48.3	1.3	48.2	2.8	48.2	1.5
11100	1.52	2.11	48.5	0.9	47.9	3.5	47.9	2.6
11120	1.68	2.05	48	1.9	47.5	6.7	47.5	4.8
11140	1.78	2.25	48	1.2	47.8	4.3	47.8	3.1
11160	1.56	2.1	48	2.2	47.2	3.8	47.2	1.6
11180	1.75	0.82	48.9	1.2	48.2	0.3	48.2	-0.9
11200	1.61	2.17	48.3	2.2	47.6	5.5	47.6	3.3
11220	1.6	1.91	48.2	1.1	47.4	6	47.4	4.9
11240	1.52	1.87	48.1	1.6	47.4	7.5	47.4	5.9
11260	1.68	2.05	48	1.9	47.5	9.7	47.5	7.8
11280	1.78	2.25	48	1.2	47.8	3.3	47.8	2.1
11300	1.56	2.1	48	2.2	47.2	1.6	47.2	-0.6
11320	1.57	2.09	48.1	1.1	47.9	1.3	47.9	0.2
11340	1.63	2.02	48.5	1.6	47.9	0.7	47.9	-0.9
11360	1.51	2.06	48.4	1.9	47.6	0.8	47.6	-1.1
11380	1.7	2.25	46.9	1.8	46.5	25.8	46.5	24
11400	1.74	2.1	48.4	2.1	47.8	10.2	47.8	8.1
11420	1.79	2.32	47.5	2.9	46.8	7.6	46.8	4.7
11440	1.91	2.16	47.6	0.9	47.6	3.9	47.6	3
11460	1.56	2.1	48	2.2	47.8	0.9	47.8	-1.3

11480	1.57	2.09	48.1	1.1	47.9	1.3	47.9	0.2
11500	1.68	2.05	48	1.9	47.5	9.7	47.5	7.8
11520	1.78	2.25	48	1.2	47.8	3.3	47.8	2.1
11540	1.56	2.1	48	2.2	47.2	1.6	47.2	-0.6
11560	1.57	2.09	48.1	1.1	47.9	1.3	47.9	0.2
11580	1.73	2.07	48.4	1.9	47.5	10.8	47.5	8.9
11600	1.6	1.91	48.2	1.1	47.4	11.1	47.4	10
11620	1.52	1.87	48.1	1.6	47.4	2.6	47.4	1
11640	1.6	1.92	48.4	1.1	47.8	5.7	47.8	4.6
11660	1.56	2.11	47.8	1.4	47.1	1.9	47.1	0.5
11680	1.69	2	48.4	1.3	47.8	0.9	47.8	-0.4
11700	1.68	2.05	48	1.9	47.5	6.7	47.5	4.8
11720	1.78	2.25	48	1.2	47.8	4.3	47.8	3.1
11740	1.56	2.1	48	2.2	47.2	3.8	47.2	1.6
11760	1.75	0.82	48.9	1.2	48.2	0.3	48.2	-0.9
11780	1.61	2.17	48.3	2.2	47.6	5.5	47.6	3.3
11800	1.6	1.91	48.2	1.1	47.4	0.9	47.4	-0.2
11820	1.73	2.07	48.4	1.9	47.5	19.5	47.5	17.6
11840	1.6	1.91	48.2	1.1	47.4	11.1	47.4	10
11860	1.52	1.87	48.1	1.6	47.4	2.6	47.4	1
11880	1.6	1.92	48.4	1.1	47.8	5.7	47.8	4.6
11900	1.56	2.11	47.8	1.4	47.1	1.9	47.1	0.5
11920	1.74	2.2	47.4	2.3	47	13	47	10.7
11940	1.5	1.87	47.3	2.1	46.8	5.9	46.8	3.8
11960	1.36	1.68	48.5	1.1	48	0.5	48	-0.6
11980	1.99	1.58	47.8	2.1	47.6	3.3	47.6	1.2
12000	1.89	2.53	48.9	2.1	48.1	2.2	48.1	0.1
12020	0	0.8	48.3	2.5	47.5	0.5	47.5	-2
12040	1.6	2.08	45.8	2.2	45	19.3	45	17.1
12060	1.5	2	48.8	1.1	48.3	0.6	48.3	-0.5
12080	0	0.87	48.8	1.1	48.4	0.1	48.4	-1
12100	1.4	1.68	48.3	2.1	47.8	0.5	47.8	-1.6
12120	1.3	1.57	48.1	2.1	47.8	0.2	47.8	-1.9

Appendix G

carc

Control & Applications Research Centre

Control & Applications Research Centre



Training Manual



ELECTRICALLY ASSISTED RICKSHAW-VAN WITH TORQUE SENSOR

This unit has been a project of Control and Applications Research Centre (CARC) of Electrical and Electronic Department, BRAC University.

All rights reserved under the authority of CARC, BRAC University

The use of any of the unit without any acknowledgement from any of the responsible body of this project will be considered as a crime and under the authority of BRAC University; the responsible person behind such act will be prosecuted.

Under no circumstance shall this project be dismantled, displaced or modified without proper authorization from the responsible bodies of this project.

<http://carc.bracu.ac.bd/>

Caution for the Van

Whenever a vehicle has to depart from its garage, safety is always a concern. For this van, you need to take some caution as same way you do for other vehicle before riding.



Avoid dirty place to park. Tires, body part, motor and many other parts can be damaged.



Avoid wet floor to park, the van contains Iron, which can cause rust.



Always carry the van's key with you; nobody knows when you need to move or ride.

Caution for the Charge Controller

The controller contains both electrical and electronic components. Improper handling can easily electrocute the user. The components are connected through various wire joints and PCB paths and thus require precise trouble-shooting when a problem occurs



The controller is an electrical device. Making it wet or washing it with water can cause severe damage to the controller, even can result in fire.



The controller contains both electrical and electronic components. Improper connections or short circuit can cause severe damage to the components or catch fire.



Always keep the PV panel neat and tidy. Tidiness will increase the efficiency significantly.



Do not put any heavy object on top of the controller, which can cause severe malfunction and unexpected results.

Caution for the Battery



Do not over-charge the batteries.



Keep the batteries in cool/dry place.

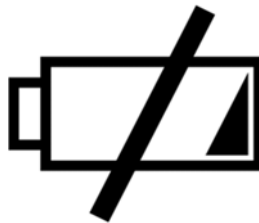

Do not use the van when the battery signal is low or below 30%.

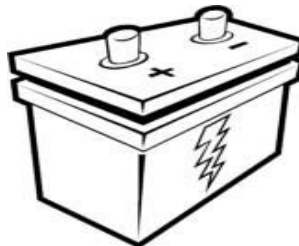

To keep the van healthy, change the whole sets of battery in every 2 years.

Caution for the Puller



Always wear shoe while driving, **avoid slippers.**



Always carry a handkerchief.



Try to keep a mobile phone for emergency purpose.



Always keep the training manual within the van.

The Vehicle at a Glance



Side view of the vehicle



Front view of the vehicle



Rear view of the vehicle

The tri-wheeler motorized rickshaw was manufactured by Beevatech Limited and initially it was a full throttle controlled motorized rickshaw-van. Later PV array and torque sensor pedal was installed. Rickshaw-van is made with light weighed steel body and a different architecture compared to the traditional rickshaw or vans. The rickshaw-van is capable of carrying greater number of passengers compared to the traditional rickshaw or van. Usually traditional rickshaw-van is capable of carrying 3 or 4 passengers, whereas the motorized rickshaw-van is capable of carrying 6 to 8 passengers.

The two major components, PV array and torque sensor pedal are installed in the system to enhance the performance of the tri-wheeler and increase the distance coverage of the rickshaw-van compared to normal battery operated rickshaw or rickshaw-van. The torque sensor pedal mainly reduces the overuse of the battery-bank. . The motorized rickshaw-van had a brushless DC gear motor, four 12V 25Ah lead acid batteries connected in series, a controller unit, a throttle, main power key, emergency motor stopper, traditional front wheel brake and an extra rear wheel break, charge controller, charge indicator and other components. The details of all the components are mentioned in the following sections.

Components

The Batteries

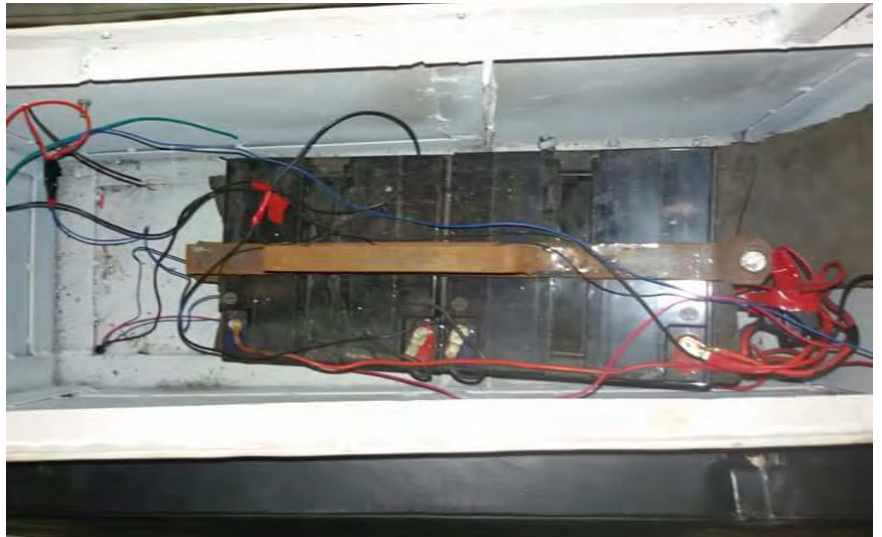

Fig: Two Batteries

Four 12V, 25Ah Rechargeable batteries were connected in series, that supplies 48 Volts to the BLDC motor. These were lead-acid batteries. Each battery was 16.5 X 17.5 X 12.6 cm in dimension. The batteries are placed under both the seats. Each fully charged battery shows 12.7 volts across their terminals and 50.8 volts after connecting those in a series combination.

The Controller Box

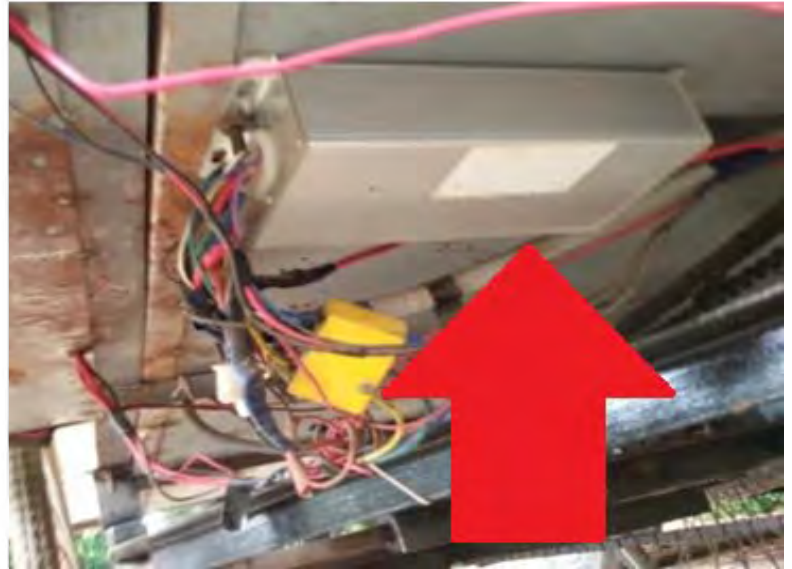
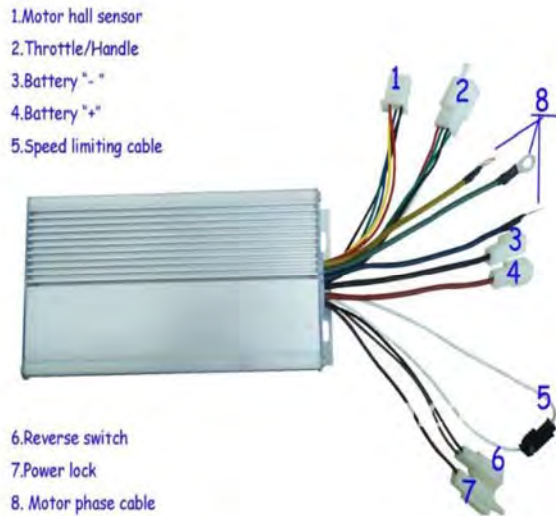

Fig: Controller box

The manufacturer integrated all the complicated electronics the brushless motor needs into a white box.[12] But due to the unavailability of proper resources, the controller wires were identified using some online resources, experiments, and exploring the connections in the system.[12]

The Throttle



Fig: Throttle

The BLDC motor used throttle to control the speed of the motor. A throttle is a specially designed potentiometer. It has a biasing voltage of 5V which is provided by the motor controller unit. Its output voltage depends on the angle of the throttle. The output voltage is supplied to the controller. The speed of the motor depends on its output voltage. The motor speed increases as the output voltage increases. The motor started when the output voltage is 1.4 Volt, and when the output voltage is 3.5 volt the motor rotate at its maximum speed.

The Power Key and charge indicator



Fig: Power Key and charge indicator

A power key was used to turn the whole system 'on' or 'off' manually in the system. The rickshaw-pullers have to turn it on before they can use the throttle to drive the motor. It was a mechanism to 'short' two wires that go directly to the controller unit. Normally the wires are open switching 'off' the whole system. When it is keyed, the wires get 'shorted'.

The charge indicator showed the state-of-charge of the batteries from the moment it was connected across the 48V batteries. The charge indicator did not have a switch. There were three lead lights, when all three lights glow that indicates SOC of the battery is above 99%, when first light goes off it indicates SOC is above 67%, when second light goes off it indicates SOC is below 66% and when third light goes off it indicates SOC is below 33%.

The Solar panel



Fig: Solar Panel

Solar panel is placed at the top of the van on an iron frame. Four 100W, 12V panels are connected in series that provides **48V** to the batteries through the charge controller.

The Torque Sensor



Fig: Torque sensor

The torque sensor is a device used to measure and record the torque of a rotating system. It needs a biasing voltage of 5volt from the DC source to operate. As the torque increases output voltage increases. The speed of the motor is directly proportional to the output voltage.

The Break System



Fig: Hand-clutch and rear wheel brake pedal

Traditional hand-clutch brake is used to stop the front wheels. Another hand-clutch is placed on the left hand-side along the traditional hand-clutch. This hand-clutch is used to stop the motor at once. When the hand-clutch is released, it returns to its original position and it allows the motor to start again when needed. A rear wheel brake pedal is introduced in the system to stop the rear wheels. The rear wheel brake is a mechanical brake similar to cantilever brake that helps in stopping the moving central shaft or axle and thus stopping the rear wheels.

Getting started



First look around the van, move obstacles, if there is any.



Clean the vehicle.

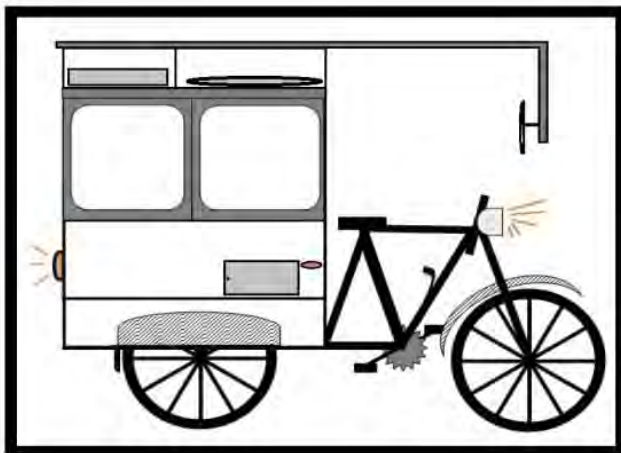

Check the total system like indicators, brake, tire condition, head-light, brake- light and the accelerator.

*Switch off the van, and **getting**. (Before getting in, make sure that your **Right-hand** is **not** in the accelerator)*

How to Drive



Get into the van



Keep the hand align with the steering



Insert the key to the key-holder, and rotate the key to the right to start the vehicle.

And Press clutch and rotate the throttle anti-clockwise slowly and release the clutch



As the vehicle start running slowly rotate the throttle more to increase the speed



When the vehicle reaches certain speed start pedalling

Speed depends upon pedalling, if you pedal fast, speed of the motor increases; to drive straight keep the handle of the vehicle straight.

How to take turns

To take **Right** turn:



Switch on the right indicator



Slow down the speed of the vehicle by pressing front brake and leg brake.



Use right hand indication, show the direction

Slowly move the van to the right and take turn

To take **Left** turn:



Switch on the left indicator



Slow down the speed of the vehicle by pressing front brake and leg brake.



Use left hand indication, show the direction

Slowly move the van to the left and take turn

How to brake



Do not over speed.

*Maintain a speed limit of maximum
25km/h*



Press both
Front brake
and Leg
brake if
there is any
obstacle
within 3m.

Maintenance



Inflate the wheels.

Repair or change the tube of the tire if tube is leaked



Lubricate the chain regularly

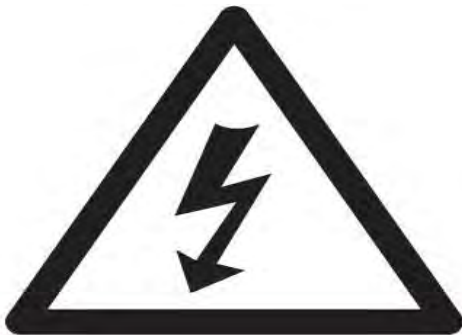

Discharged battery should be charged as early as possible.



Keep vehicle and top of PV panel neat and clean

Vehicle Troubleshooting

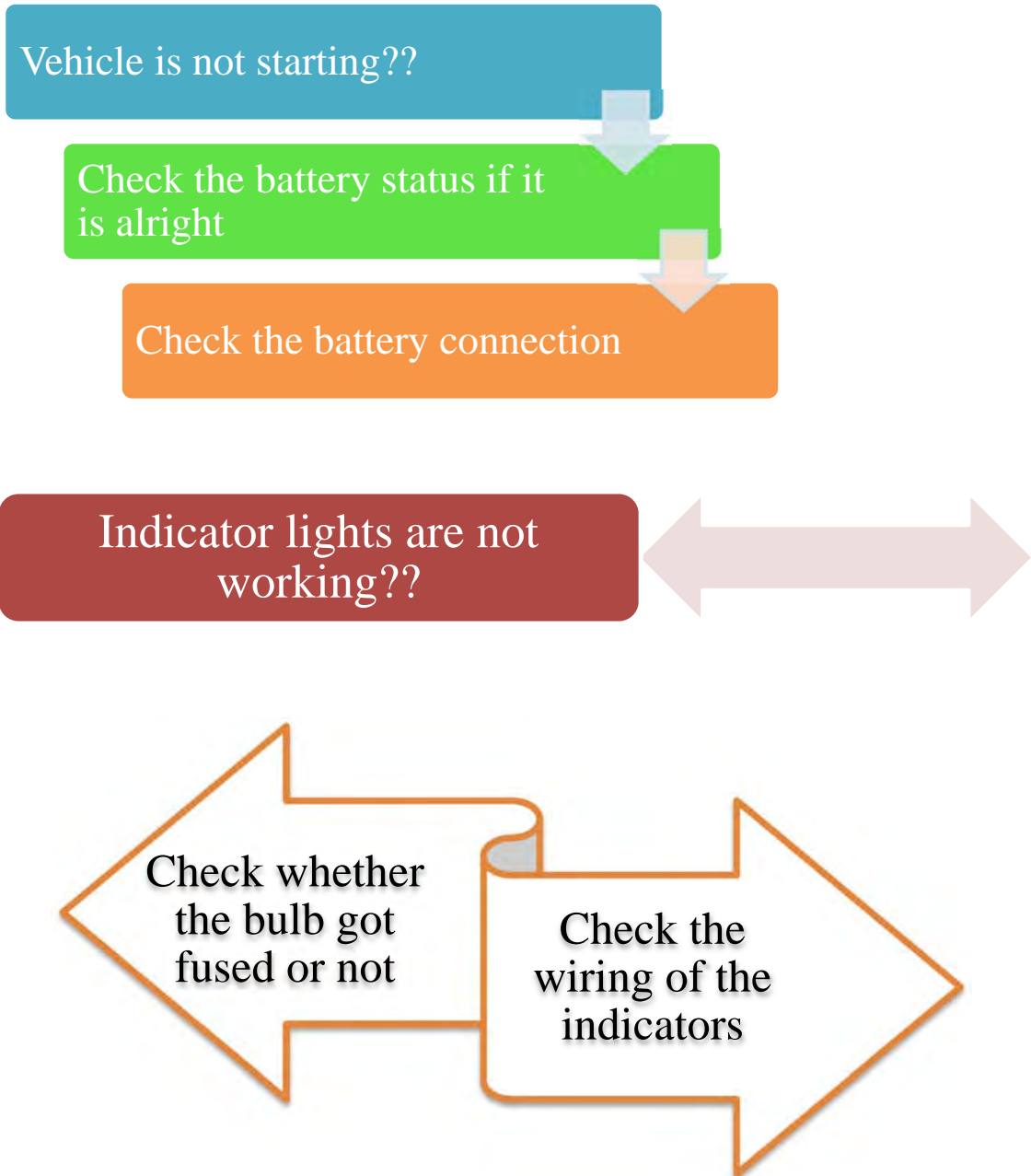

Face
problem
while
paddling??

Lubricate the
chain

Motor is not
getting back up
from PV panel??

- Check the connection of Charge controller and PV panel

In this manual we have explained to you how much user-friendly the vehicle is and how to carry out maintenance and do possible small repairs. If you find something a bit technical or don't completely trust your own skills, feel free to contact us. Drive safe.

