

MUSEUM AND RESEARCH CENTER FOR THE TRADITIONAL TEXTILES OF BANGLADESH

Syeda Mushda Ali

10108006

ARC 512 SEMINAR II

Submitted in partial fulfillment of the requirements

for the degree of Bachelor of Architecture

Department of Architecture

BRAC University

Contents

Chapter 1: Background of the Project.....	3
1.1 Project Brief	4
1.2 Project Introduction	4
1.3 Aims and Objectives of the Project	5
1.4 Proposed Program.....	5
Chapter 2: Site Appraisal	6
2.1 Site Location	7
2.2 Site Surrounding	11
2.3 Background and Current Condition of the Site	14
2.4 Landuse and Topography	15
2.5 Climate	17
2.6 SWOT Analysis.....	19
Chapter 3: Literature Review	20
3.1 Traditional Textiles of Bangladesh	21
3.2 History of Traditional / Handloom textiles of Bangladesh	21
3.3 Types of Handloom.....	23
3.4 Tools and Methods used in Handloom production	24
3.5 Significant Traditional textiles or Handlooms of Bangladesh	30
3.5.1 - Jamdani	30
3.5.2 - Benarasi.....	33
3.5.3 - Khadi.....	36
3.5.4 – Nakshi Kantha	37
3.5.5 - Tribal Textiles.....	42
3.6 Present Scenario of Handloom Industry.....	44
3.6.1 - Important Products with Places of Production	44
3.6.2 – Current Statistics	45
3.6.3 - Distribution of Looms by Type	46
3.6.4 - Handloom Concentrated Districts	46
3.6.5 - Problems of Handloom Industry	47
3.7 Ergonomics Standard Study for Project Related Spaces	49
3.7.1 Library	49
3.7.2 Museum	52
Chapter 4: Case Studies	55
4.1 Kolkata Museum of Modern Art.....	56
4.2 GC Prostho Museum & Research Center	62
4.3 Museum of Handcraft Paper	68

Chapter 5: Program Development.....	74
5.1 MUSEUM.....	75
Administration	75
5.2 RESEARCH CENTER	76
Workshops	76
Research Lab.....	76
Administration	77
Library.....	77
5.3 Recreational / Common Area.....	78
5.4 Grand Total.....	78
Chapter 6: Conceptual Stage and Design Development.....	79
6.1 Introduction.....	80
6.2 Concept Development	80
6.3 Form Development & Programmatic Layout	82
6.4 Final Design Drawings	86
6.5 Final Design Model	94
CONCLUSION	96
REFERENCES.....	97

Chapter 1: Background of the Project

1.1 Project Brief

1.2 Project Introduction

1.3 Aims and Objectives of the Project

1.4 Proposed Program

1.1 Project Brief

Project Name: Research Center and Museum for the Traditional Textiles of Bangladesh

Function: Research Center promoting the development and sustainability of Traditional textiles and its products, and a Museum showcasing the rich heritage of the textiles of Bangladesh

Site: Purbachal

Site Area: 1, 20, 000 sqft

Client: Monira Emdad, CEO, Tangail Saree Kutir / Bangladesh Crafts Council

1.2 Project Introduction

Looking back into the history of the Bengal in the Indian subcontinent, traditional handloom textiles have been an integral part of our rich heritage for a long time. The Bengal has been blessed and subsequently awed at for the works produced with the likes of intricately delicate materials such as the Muslin, and thereafter the Cotton and the Silk.

Historically, handloom has got its predominance and heritage deeply rooted in Bangladesh. In itself, the tradition of weaving cloth by hand is one of the richer aspects constituting Bangladeshi culture. The level of artistic prowess and intricacy achieved in such fabrics are unique and unparalleled. The handloom can meet a wide range of uses, from the needs of the daily life to being an exquisite heirloom.

According to the Bangladesh Handloom Board, the handloom sector in Bangladesh consists of more than 1.83 lakh handloom units with 5.05 lakh handlooms and about 10 lakh handloom weavers of which about 50% are female workers. A manpower of about one million weavers, dyers, hand spinners, embroiderers and allied artisans have been using their creative skills into more than 3 lakh active looms to produce around 6870 lakh meters of fabrics annually. Production of these handloom fabrics is diffused in numerous production centers all over the country which are linked up by a network of primary, secondary and central markets.

There are over 25 different kinds of weaves in Bangladesh and easily over 50 different crafts, but despite their diversity the crafts in Bangladesh are dying. We have limited access to them and by the time they reach our shelves they have been rendered too conventional and uninspiring, and lost its true character.

On most occasions it is also true that the creators of these beautiful crafts sink deeper into poverty, paying the middleman. The government has not done enough in terms of grants. This is where designers have stepped in over the years. The established designers and brands have long been involved in the revival of many home-grown traditions. There is a resurgence of interest that has

been mutually beneficial and has to a great extent brought to the forefront many obscure traditions in handlooms and handmade products. The designers are enthusiastic about defining the spirit of the times. A vibrant makeover is just what is needed to stay relevant to the new generation wearing them. To bring much needed exposure to these crafts and quench the interests of many enthusiasts, a museum that depicts the rich history of our textiles, along with a research center that will work with the weavers and designers for the development of these crafts is what this proposal aims to entail.

1.3 Aims and Objectives of the Project

The project shall aim to shed some new light into the work that goes behind making a story of 6 yards, and bring into exposure the different kind of weaves and crafts that are existent all over the country.

To specify, the aims are to be

- To identify and locate the different types of weaves and associated crafts situated in Bangladesh
- To motivate the weavers / artisans by providing them an exposure
- To develop a strong economic foothold for the different weaves
- To provide a common platform for the easy communication of weavers and designers, students, enthusiasts and learners beyond the borders
- To promote and enlighten the audience about the illustrious textile heritage of our country

1.4 Proposed Program

- Display Area – Permanent & Temporary
- Workshops
- Library
- Research Area
 - Computer Labs
 - Workshops
- Amphitheatre
- Multipurpose Hall
- Cafeteria
- Utilities
- Administrative office
- Souvenir shops

Chapter 2: Site Appraisal

2.1 Site Location

2.2 Site surrounding

2.3 Background and current condition of the site

2.4 Landuse and Topography

2.5 SWOT Analysis

2.1 Site Location

The site is located in Sector 21, Block E-3 of the new model town of Purbachal. The site can be accessed by a 100ft wide road branching in from the 160ft wide road, which cuts across Purbachal on the Eastern side. This 160ft road is a part of the Dhaka city bypass stretching North-west towards Tongi, and South East towards the N105 Highway.

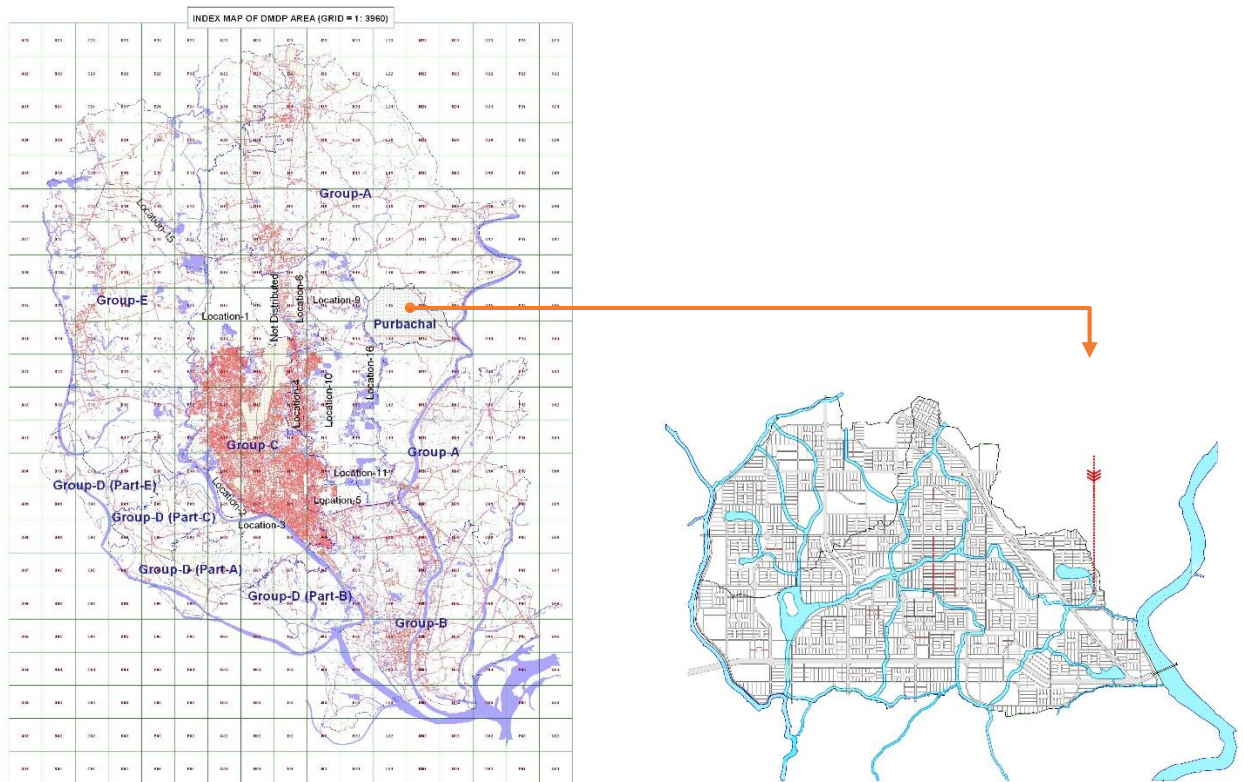

Fig 01: Location of Purbachal in comparison to Dhaka Metropolitan Development Plan

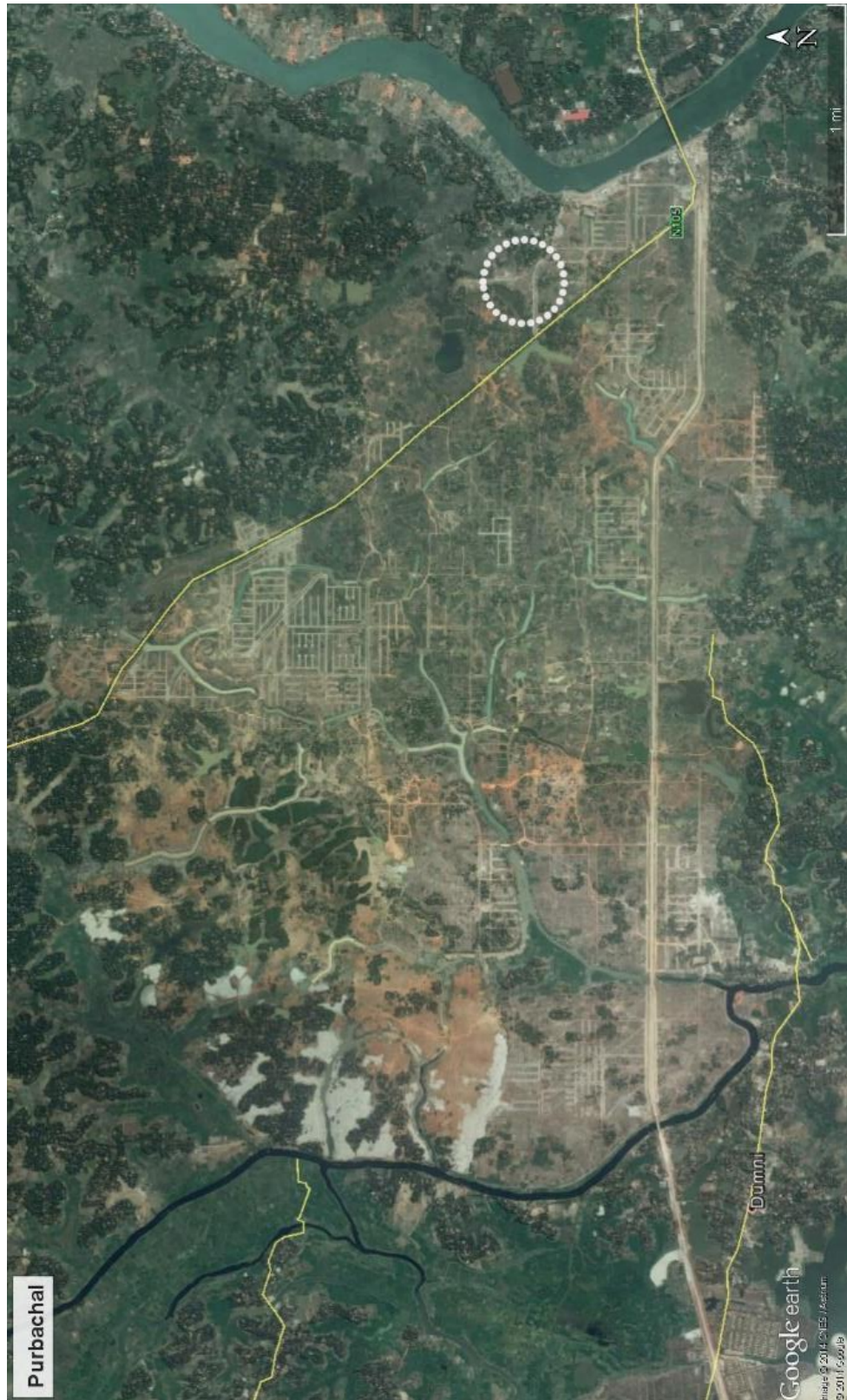

Fig 02: Satellite Image of Purbachal (with site marked)

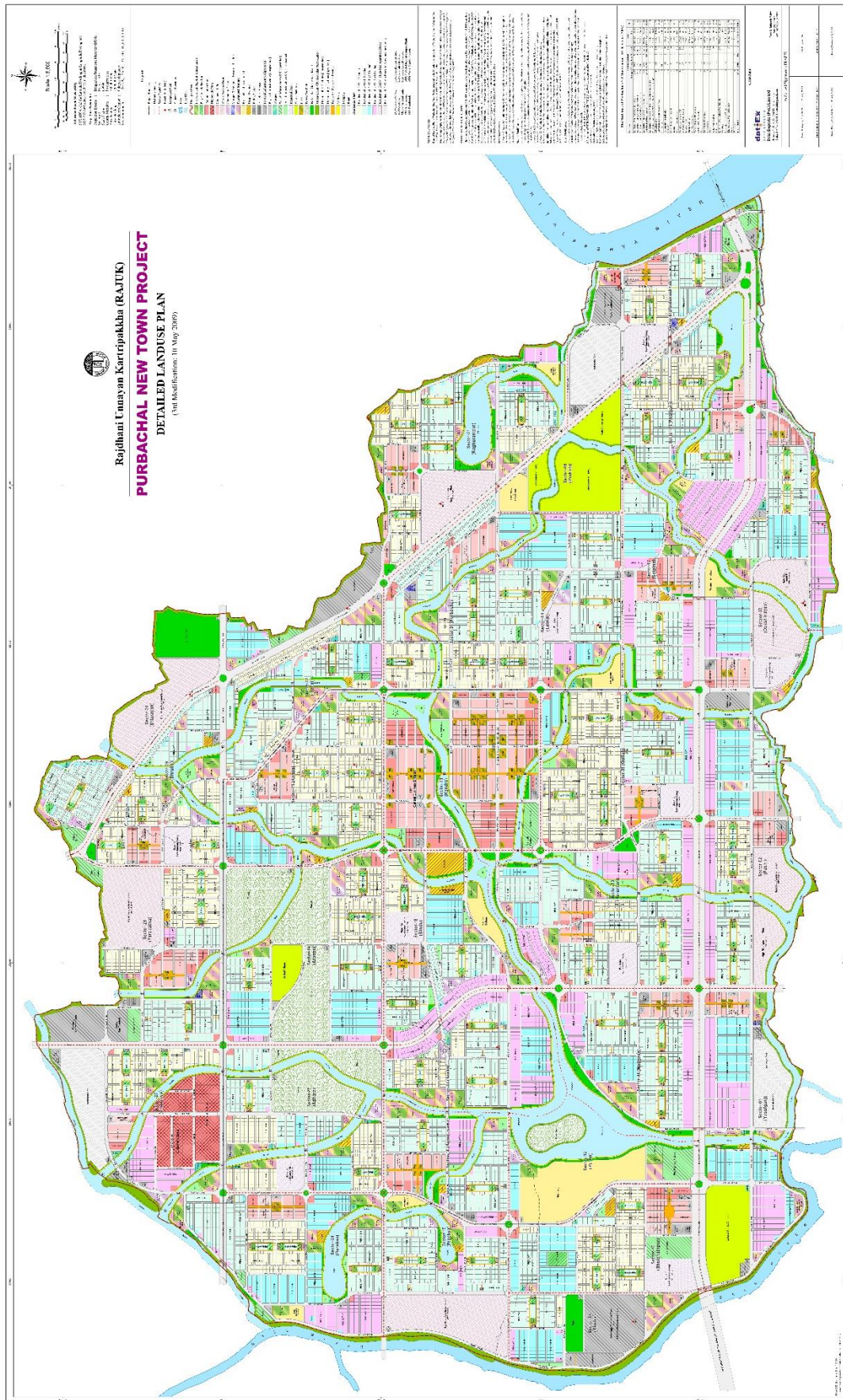

Fig 03: Detail Plan of Purbachal New Town Project

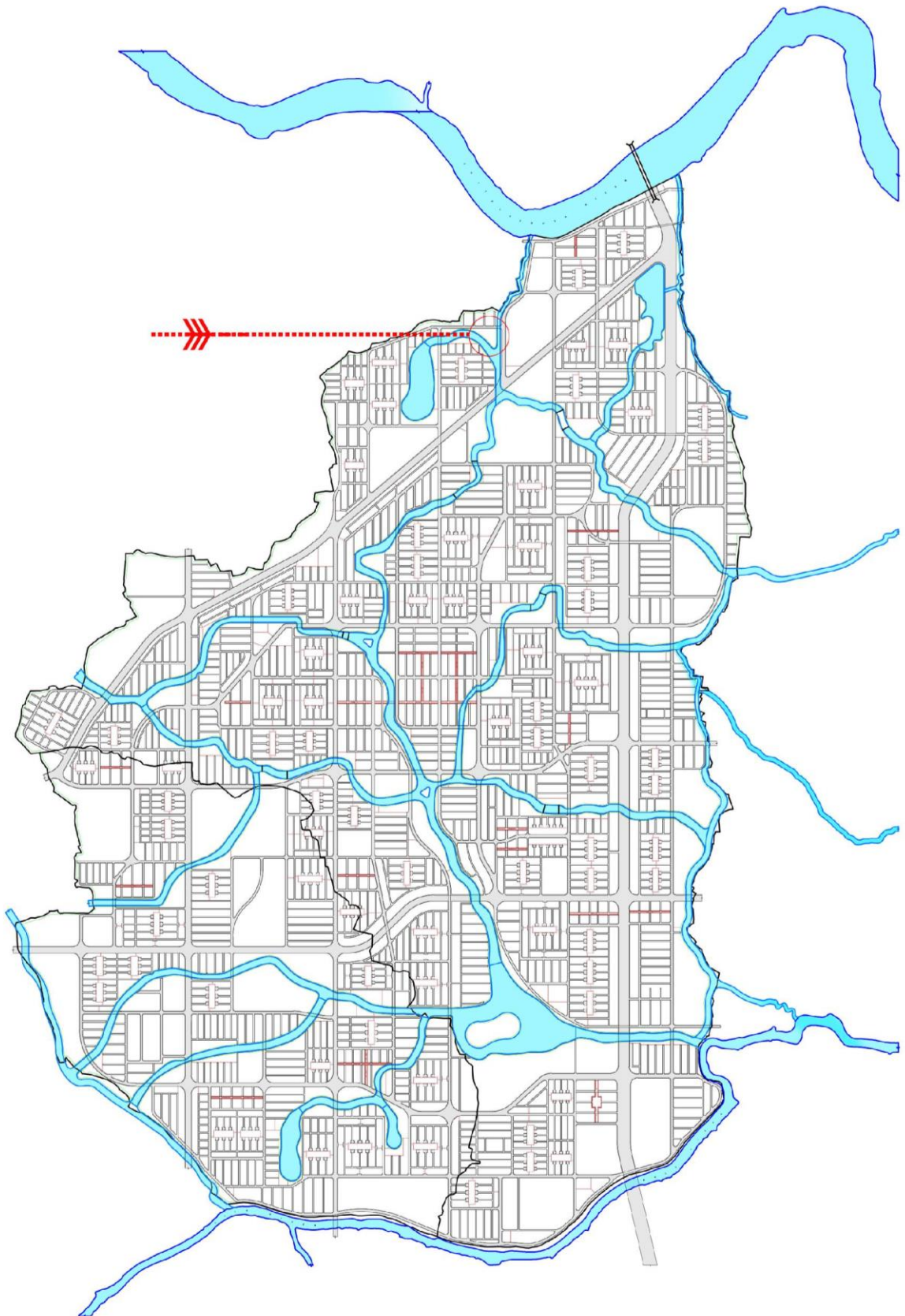

Fig 04: Road Network Layout and Water bodies of Purbachal New Town Project

2.2 Site Surrounding

The site is an approximately 1, 20, 000 sqft of land, surrounded on the North, East and South by a water body. Beyond that, on the western side, the site faces residential plots, while on the eastern side, it faces some commercial plots. A 100ft wide road runs along the southern side of the site.

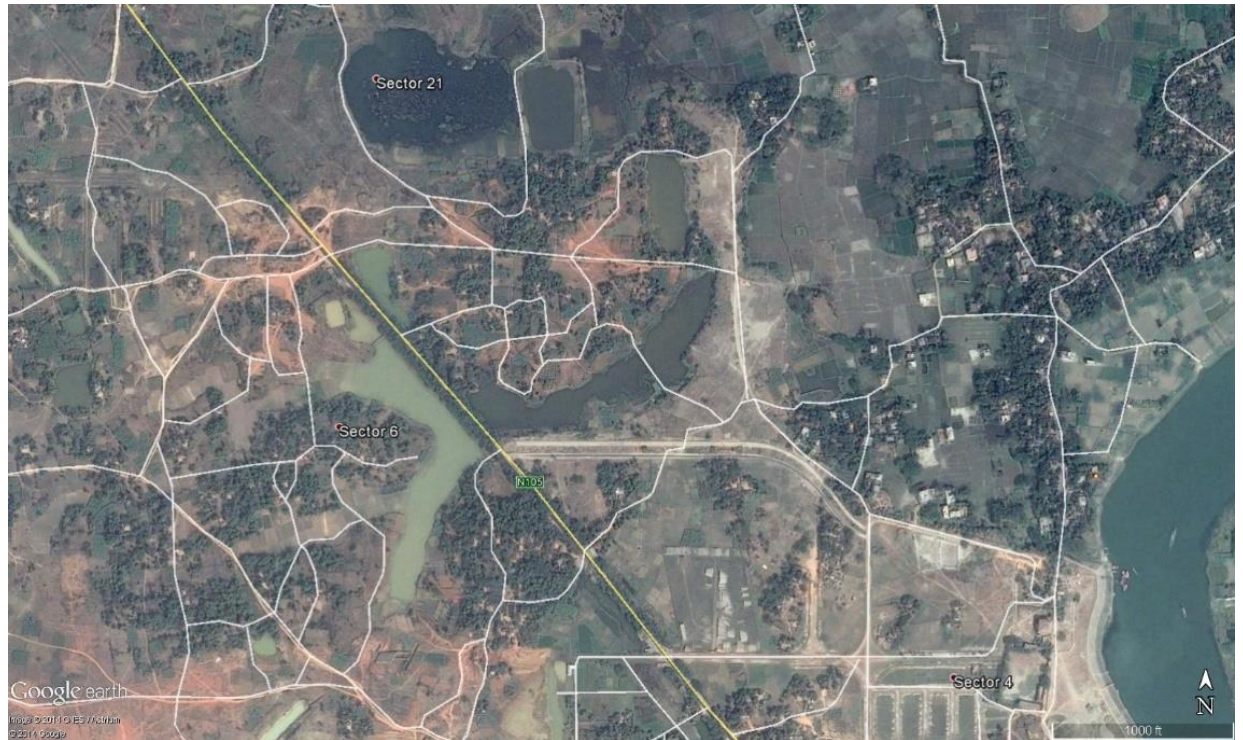

Fig 05: Satellite image of site



Fig 06: Road Network Layout surrounding the site

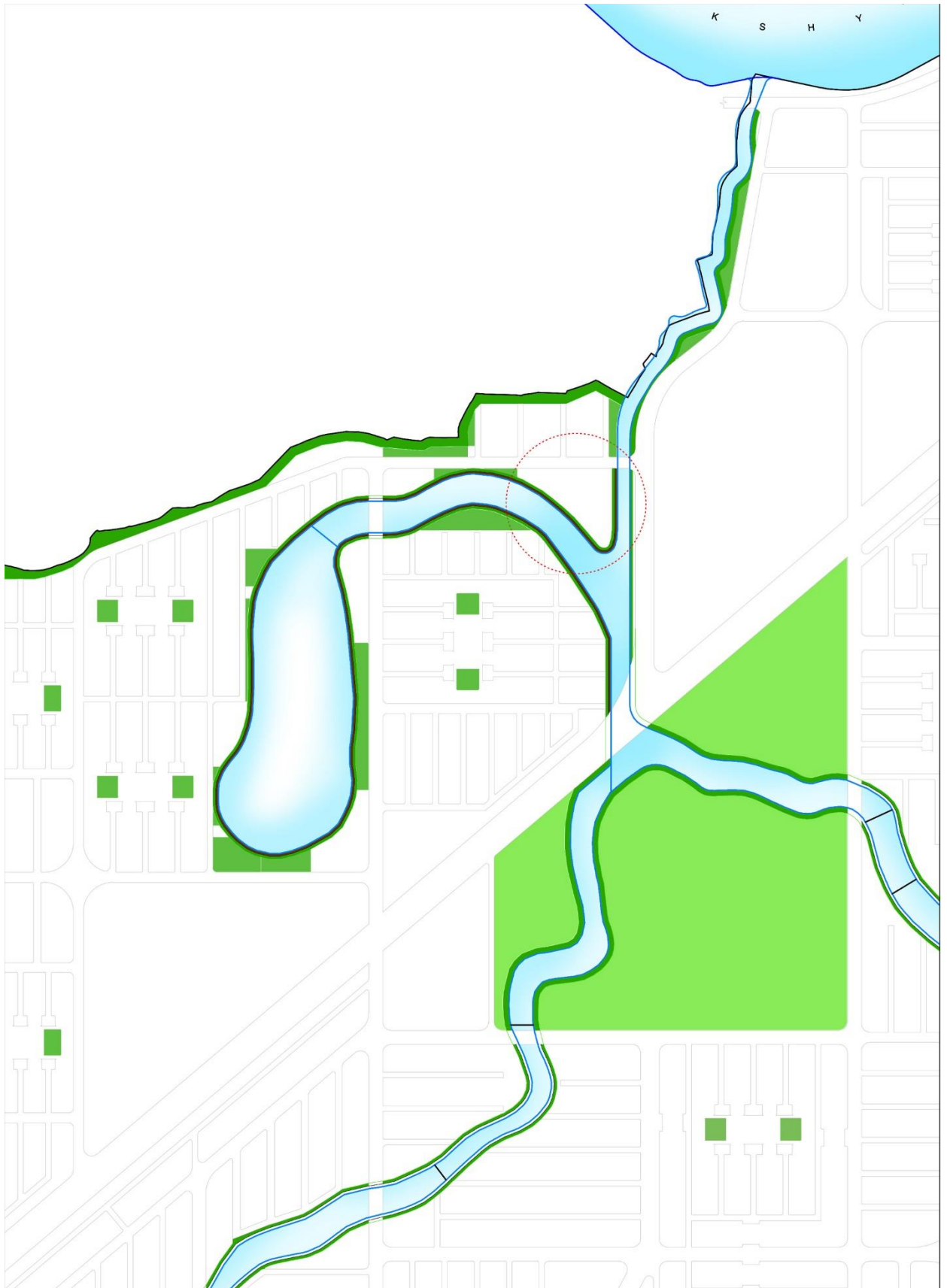

Fig 07: Urban Green, Green Belt and Vegetation surrounding the site.

2.3 Background and Current Condition of the Site

Purbachal is the biggest planned township in the country. The Project area comprises of about 6150 acres land located in between the Shitalakhya and the Balu River at Rupgonj thana of Narayanganj district and at Kaligonj Thana of Gazipur district, in the north-eastern side of Dhaka. The township will be linked with 8 lane wide express way from the Airport Road/Progati swarani crossing.

The site lies in Sector 21, on the absolute eastern side of Purbachal and is currently used as agricultural land by local residents. The site is currently being developed by land filling with sand and soil. Road network development is still in its rudimentary levels.



Fig 08: Site panorama.



Fig 08a: Site image.

2.4 Landuse and Topography

Topographically speaking, the site land is flat land, whereas there are a few mild contours in the surrounding. Having an extensively connected water-body right beside, gives the site a much substantial advantage.

The site falls under the allocated landuse of Higher Research Institute. The site falls in a bordering state between a complete residential zone, and a more industrial and urban amenity oriented zone.



Fig 08b: Site image.

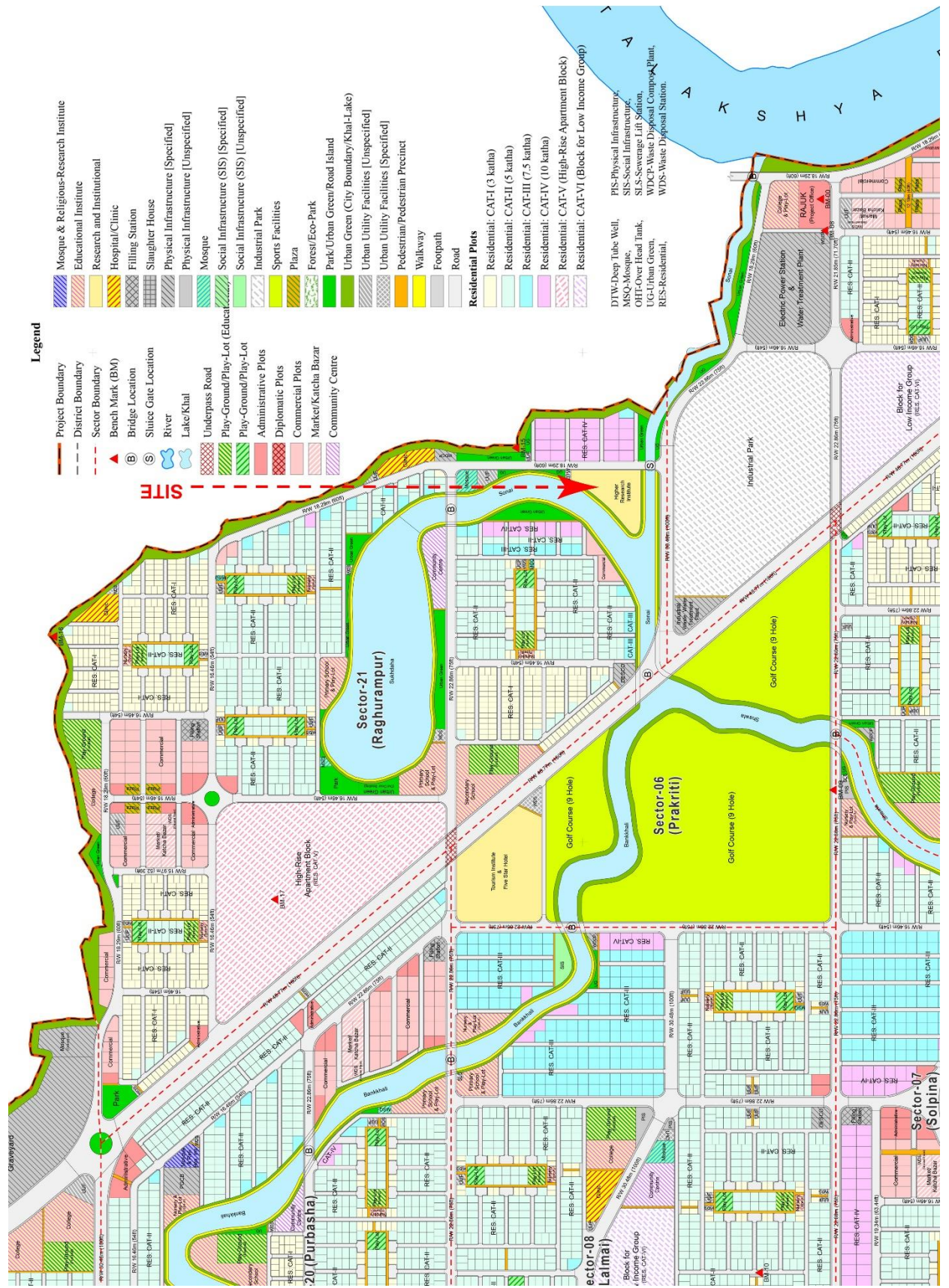

Fig 09: Landuse pattern surrounding the site.

2.5 Climate

Temperature



The climate of Dhaka is fairly equable, the maximum temperature recorded in Dhaka is 42.22°C, the minimum 5° C and the average temperature is 25.66°C. Good weather begins in November and for four months the climate is fairly pleasant. In March, however, the days grow hot. May to June is hotter. January is the coldest month.

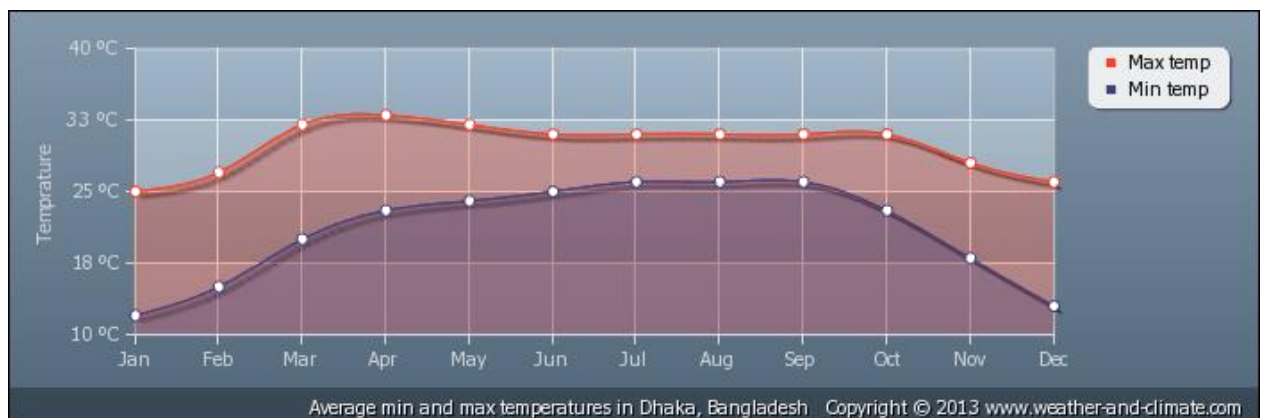

Rainfall

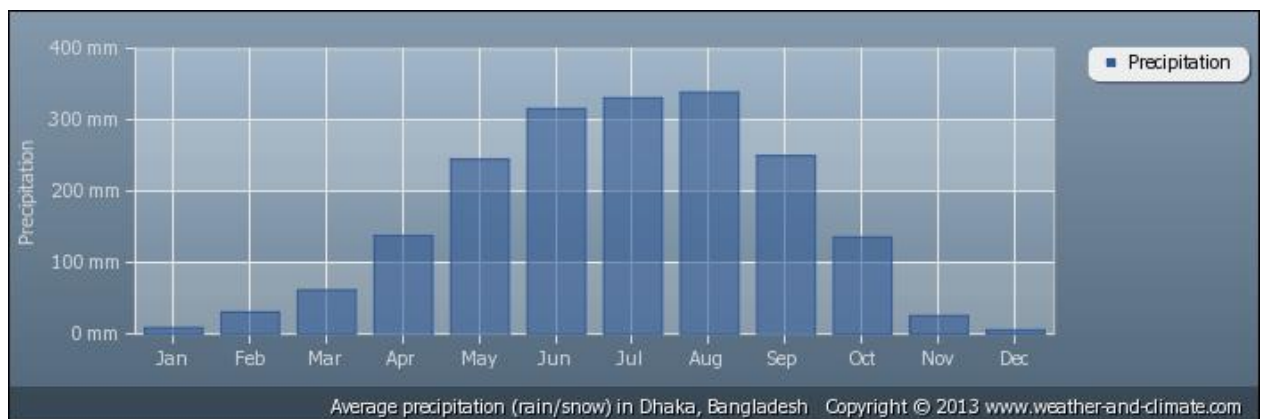

The maximum rainfall recorded in Dhaka is 2633 mm. the minimum is 1197 mm. and the normal is 1863 annually. During the dry season (from November to March) the total rainfall is 133 mm.

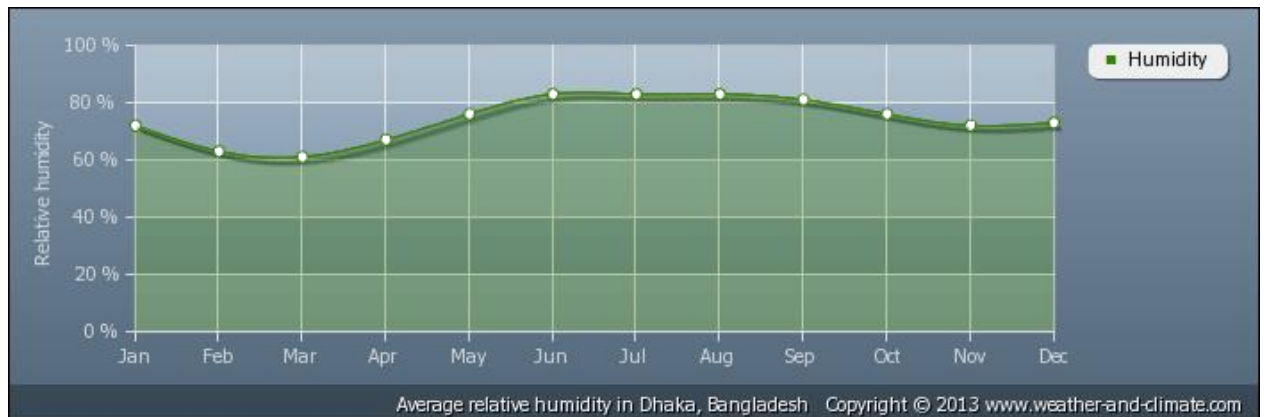

Prevailing Winds

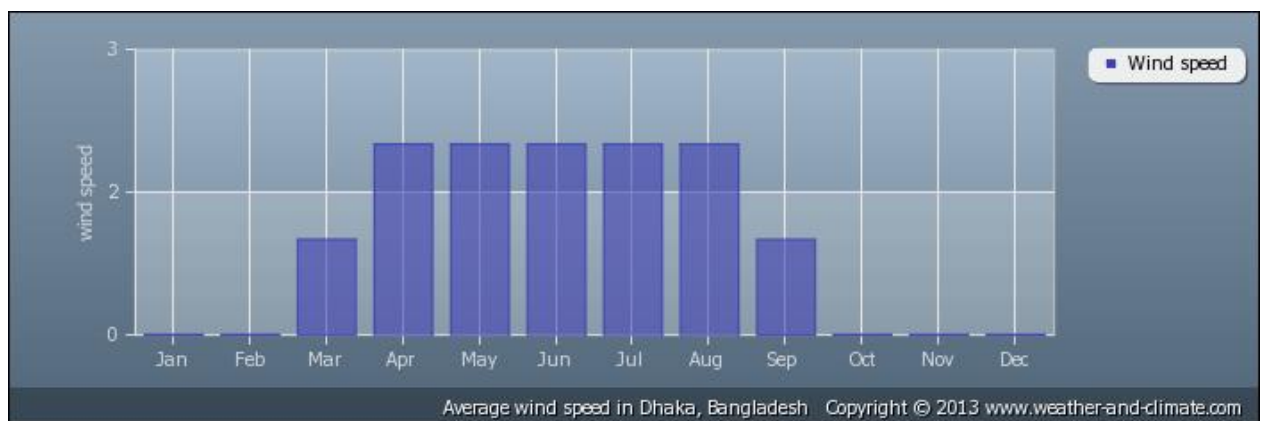

From November to March the prevailing winds are often from the north and north-west. In March sudden storms from the north-west are by no means uncommon and are a source of considerable danger to the light crafts cruising in the rivers. From April to October the wind is generally from the east and south-east. It is heavily laden with moisture, but it does much to mitigate the rigorous of the climate

2.6 SWOT Analysis

Strength

- The site is located very close to the Dhaka City Bypass, thus having an easy access from areas focused primarily on traditional handloom production such as Narayanganj, Demra, Tangail, Pathrail etc.
- The site is located right beside a water body which can act as a strong platform for positive activities and functional uses can be generated with the development of the project and its surroundings.
- The site is located on the eastern most side of the township and in one way can be seen as an isolated island, not hampering or being a nuisance to surrounding activities.

Weakness

- Being part of a proposed township, the site has got no existing urban life or features to analyze and predict accordingly.
- The site is still empty and will take much time to develop as per desired design goals.

Opportunity

- The site is located in a very strategic position, and can provide an interesting platform for the convergence of artisans and weavers from all over the country as well as designers and enthusiasts from the city and abroad.
- The site is located in a new and barren development, and holds the strength in controlling the urban sprawl that shall direct to a new visualization of the township.

Threat

- The site and its surrounding land can turn into a dense and busy city like Dhaka.
- The urban development shall disrupt the present green landscape and cause environmental harm if not addressed at with proper design.

Chapter 3: Literature Review

3.1 Traditional Textiles of Bangladesh

3.2 History of Traditional / Handloom textiles of Bangladesh

3.3 Types of Handloom

3.4 Tools and Methods used in Handloom production

3.5 Significant Traditional textiles or Handlooms of Bangladesh

3.5.1 - Jamdani

3.5.2 - Benarasi

3.5.3 – Khadi

3.5.4 – Nakshi Kantha

3.5.5 - Tribal Textiles

3.6 Present Scenario of Handloom Industry

3.6.1 - Important Products with Places of Production

3.6.2 – Current Statistics

3.6.3 - Distribution of Looms by Type

3.6.4 - Handloom Concentrated Districts

3.6.5 - Problems of Handloom Industry

3.7 Ergonomics Standard Study for Project Related Spaces

3.1 Traditional Textiles of Bangladesh

Traditional textiles of Bangladesh incorporate mostly the significant handloom industry present in the country which has been producing fine quality clothes for over centuries. Handloom is a machine or device, which is made of wood and of iron (some portion) and used to produce woven fabric. Handloom is generally run without any electrical motor, it is run by a person's hand and foot combination. Handloom weaving goes back as early as the 17th century, when this sector was an efficient sector and played important role in economic activities of the then Indian subcontinent.

3.2 History of Traditional / Handloom textiles of Bangladesh

History and archeological discovery suggest that Bengal was famous in the distant past for her textile production. Cotton was the chief raw material for textile work and it was produced abundantly in Bengal. During the First century AD, Dhaka muslin became famous in Asia and Europe.

The varieties of muslin produced in Bengal were *tanzeb*, *sarband*, *badan*, *khos*, *elebellay*, *sharbati*, *tarangam*, *kumish*, *turya*, *nayansukh*, *charkhana*, *malmal*, *jamdani*, and *addi*. Besides muslin, weavers of Bengal produced such other fine fabrics as, *shabnam* (*dewy*) and *abe rawan* (running water).

These and many other fabrics of Bengal were noted for their fineness of texture, beauty of design, intricacy of weave, lightness of weight, and durability. Tantis however, produced many different types of clothes of daily use and most of them were coarse and cheap. The finer clothes are now rare in a tanti's workshop and they survive in the profession by weaving largely the daily wears for the common people.

Duarte Barbosa, a Portuguese traveler visiting Bengal in around 1518 mentioned in his writing some outstanding fabrics like '*memona*', '*chowdari*', '*cinebafa*', and '*balilhar*'. In 1670, the East India Company delivered a comprehensive detail of weaving in places of Bengal like Dhaka, Chittagong, Laxmipur, Kishoreganj and Bajitpur. *Singham*, *kash*, *malmal*, *reshmi*, *nila* and *tofeta* were the main forms of local fabrics.

Bengal textile industry began to decline from the beginning of the colonial rule. Textile of many varieties made the principal item of export trade of Bengal during the Mughal rule. The dominant status of textiles in export trade began to decline when England began to manufacture textiles soon after the Industrial Revolution. England imposed heavy duties on Bengal textiles and thus raising its prices in Britain. On the other hand Britain was exporting textiles to Bengal market duty free. Bengal textiles thus lost the world market. By the 1830s, Bengal lost her dominance in

exporting textiles in the world market. From the 1850s, Bengal was turned into a market for British textiles. The main victims of British colonialism were the Tantis, who left textile manufacture for agriculture. (*Banglapedia*)

After 1947 and the partition of East and West Pakistan from India, most of the capital and resources of Pakistan came under the control of West Pakistanis. The textile industry thus stagnated in East Pakistan as momentum for development shifted from the eastern part of the country to the west. The west also grew more cotton than the east, which was used as a plea for developing the industry in the west instead of in the east. The majority of all industries in the east were also owned by West Pakistani industrialists. When Bangladesh gained its independence from Pakistan in 1971, the new government nationalized the textile industry, as it did with many other businesses in which West Pakistanis had been the principal owners. Although there were some Bangladeshi industrialists, they did not form a large or politically powerful group and thus had to surrender control of their factories to the government as well. All of the country's textile factories were then nationalized and organized under the Bangladesh Textile Mills Corporation, or BTMC. During the Pakistan period, the Pakistan Government allowed import of yarn on open general license and abolished sales tax on handloom products, which led to a tremendous growth of the industry in the early 1950s. After independence, Bangladesh Government set up a new Handloom Board in 1978, which took over the development of the handloom industry from the Small, and Cottage Industries Corporation. Since its formation, the Handloom Board has taken some policy measures to develop the industry. Handloom is considered as a priority sector for development because of some of its characteristics such as labor intensity, female employment, product demand and profitability. (*Bangladesh Cotton and Textile Convention, 2006*)

Currently, Handloom sector in Bangladesh consists of more than 0.183 million handloom units with 0.505 million handlooms and about 1 million handloom weavers of which about 50% are female worker. A manpower of about one million weavers, dyers, hand spinners, embroiderers and allied artisans have been using their creative skills into more than 0.30 million active looms to produce around 687 million meters of fabrics annually. Production of these handloom fabrics is diffused in numerous production centers all over the country which are linked up by a network of primary, secondary and central markets. (*Bangladesh Handloom Board, 2010*)

3.3 Types of Handloom

There are two types of looms namely, handloom and power loom according to operational practice. A loom may be operated manually or mechanically. Normally handlooms are those, which are manually operated, and as such, these are distinct from power looms, which are operated by power. The Bangladesh Handloom Board (BHB) ordinance, 1977 defines 'handloom' as a 'weaving device operated manually for production of fabrics other than hundred percent silk or artsilk'.

There are several types of handloom in Bangladesh. Such as:

- a. Pitloom,
- b. Power loom,
- c. Chittarranjan Loom,
- d. Benarosi and Jamdani Loom,
- e. Kamer / Waist Loom

Among all types of loom Benarosi looms are concentrated in Mirpur area, Dhaka, the Jamdani looms are specially operated in Ruggang (Taraboo) area of Narayangang District and Kamer / Waist loom is found in the Hill Tracts of Chittagong.

The vast majority of Bangladeshi handlooms are engaged in weaving cotton and blended fabrics although handloom cloth of silk earned a good reputation. Famous areas for silk weaving are Rajshahi, Tangail and Nobabgonj. Rajshahi produces mainly silk sarees, a special type of cloth weared by the women folk. Tangail produces also silk saree namely Tangail Muslin and Narayangonj produces the famous Jamdani saree, silk sarees Tangail Muslins and famous jamdani. Zari work called brocade is also famous in Mirpur, Dhaka. In Bangladesh there are different schools of weaving on jacquard, dobby, frame and pit looms. Product assortments made of other are saree , lungi, gamcha, grameen check fabrics, printed bed covers, pillow covers, table mats, kitchen and hand towels, apron, curtain and upholstery, furnishing fabrics, bags bandage etc.

3.4 Tools and Methods used in Handloom production

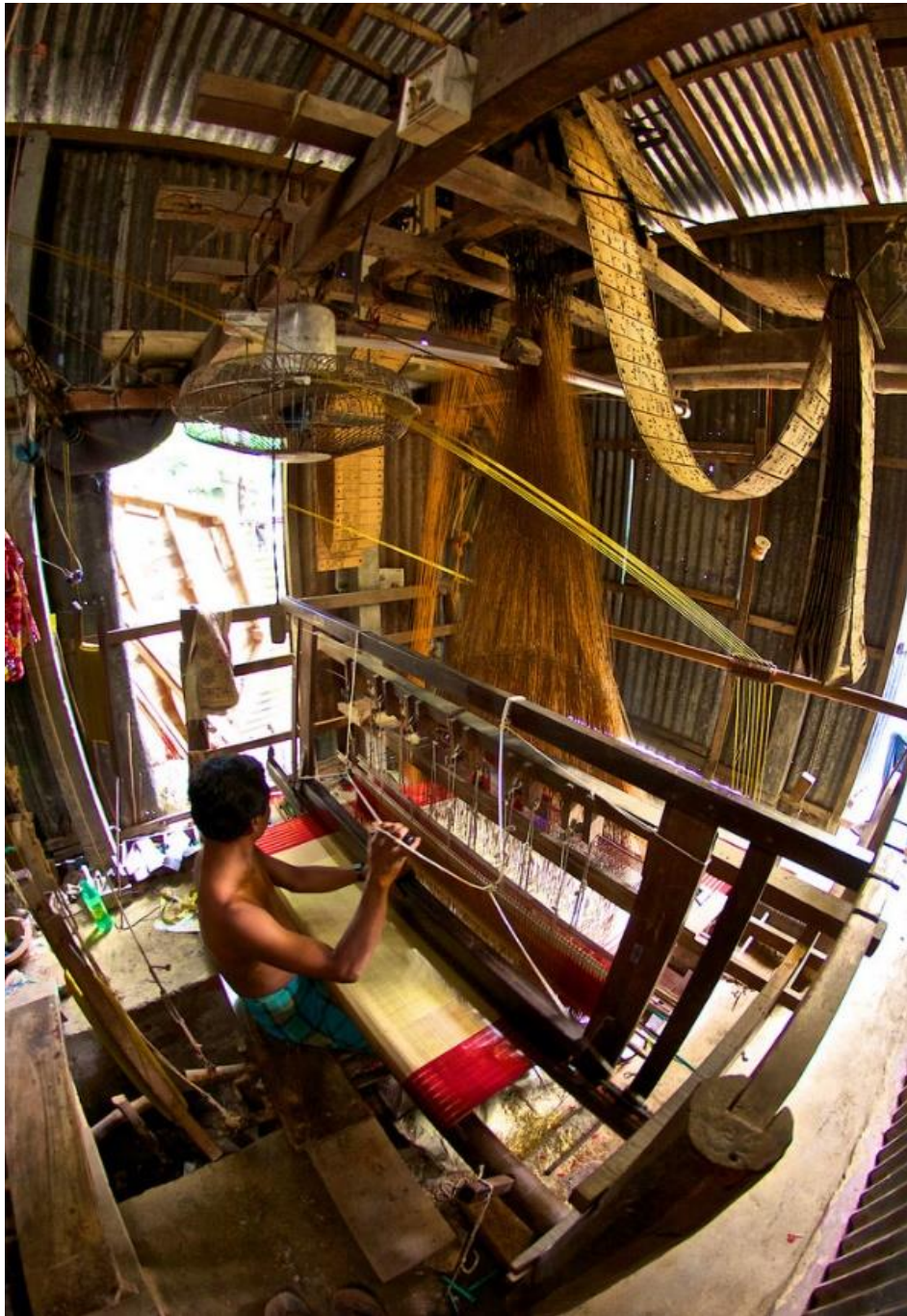

In general the different parts name of a hand loom are as like:

- Reed
- Heald shaft
- Treadle
- Cloth beam
- Shuttle
- Warp beam
- Reversing roller shaft

Fig 11: Traditional Pit-loom machine with Jacquard Weaving

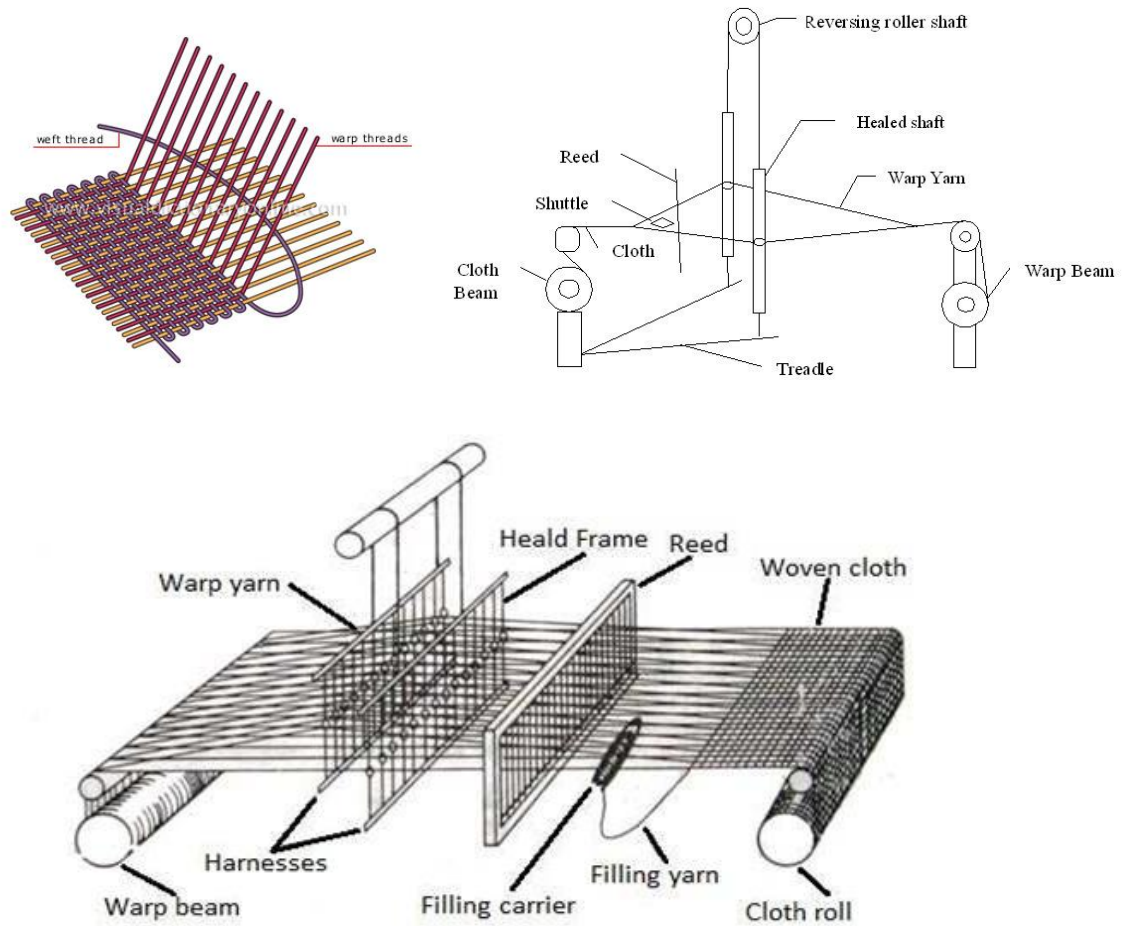

Fig 12: Basics of a Handloom

To be more accurate, Elements of a foot-treadle floor loom contain the following :

1. Wood frame
2. Seat for weaver
3. Warp beam- let off
4. Warp threads
5. Back beam or platen
6. Rods – used to make a shed
7. Heddle frame - heald frame - harness
8. Heddle- heald - the eye
9. Shuttle with weft yarn
10. Shed
11. Completed fabric
12. Breast beam
13. Batten with reed comb
14. Batten adjustment
15. Lathe
16. Treadles
17. Cloth roll- takeup

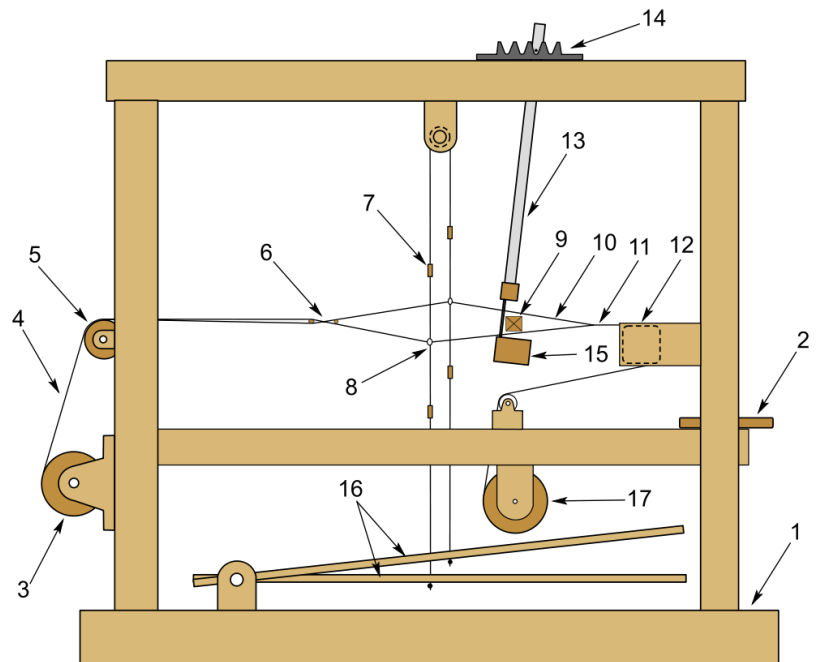

Fig 13: Basics of a Foot treadle floor loom

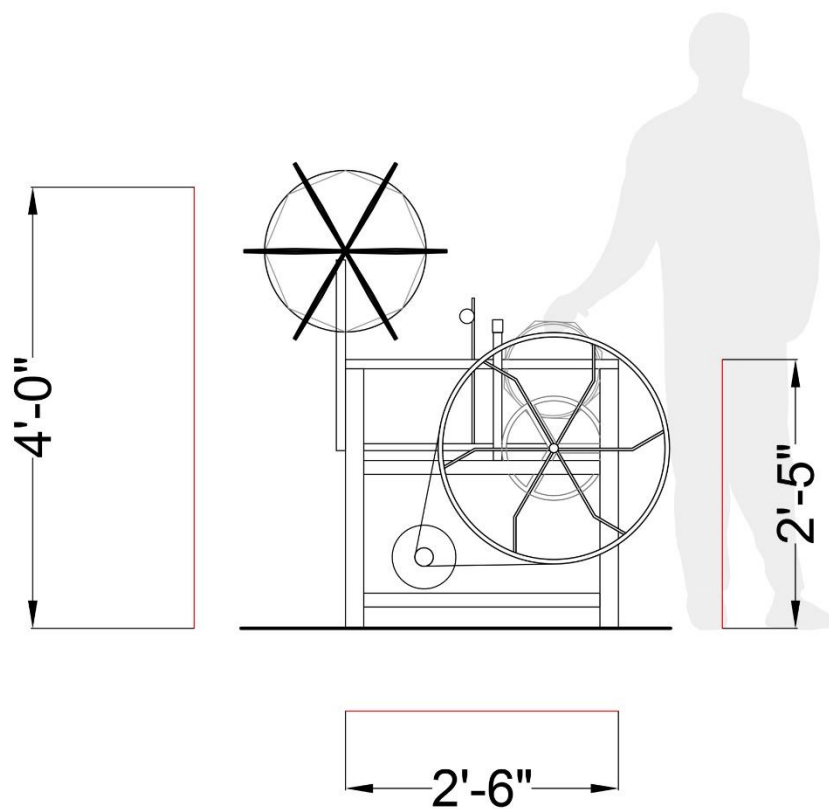
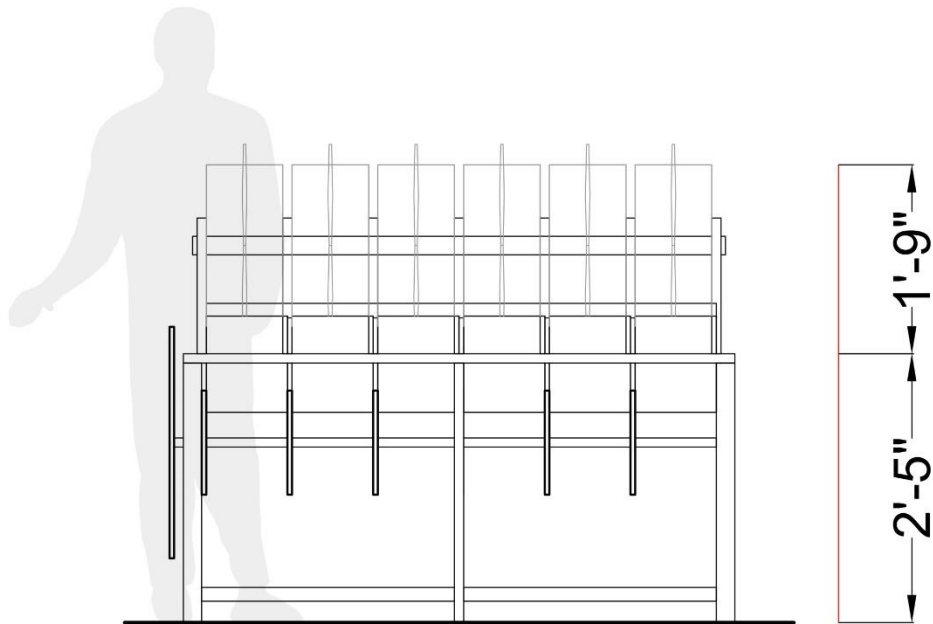

Fig 14: Traditional Pit-loom machine with Jacquard Weaving



Fig 15: Traditional Pit-loom machine with Jacquard Weaving

Multiple Automated Charka / Spinning Machine



Thread Warping Machine

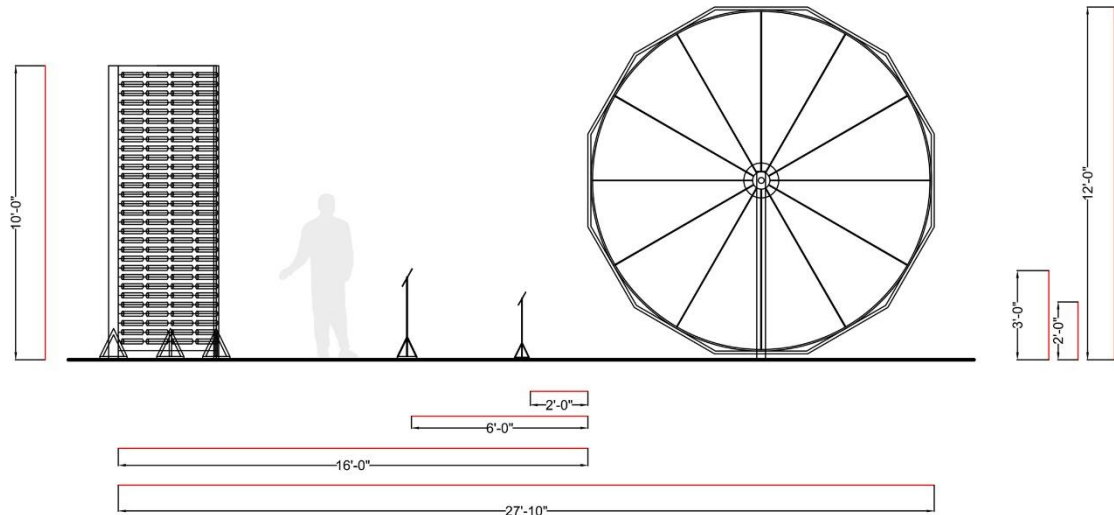

Fig 16: Thread Warping machine present in Pathrail, Tangail

3.5 Significant Traditional textiles or Handlooms of Bangladesh

3.5.1 - Jamdani



“Jamdani Saree” is a product of hand-loom and made up of cotton. This type of jamdani saree came from the idea of Muslin, another super thin and soft fabric of Bangladesh. There are some kinds of jamdani like figured or flowered jamdani and fabricated jamdani. But whatever may be the kind jamdani is undoubtedly the best cotton weaved handloom product in Bangladesh.

The origin of the word jamdani is uncertain. Jamdani is a Persian term. In Persian, ‘Jama’ means cloth and ‘dana’, means buti or diapering. Jamdani therefore could mean diapered cloth. It is believed that

Muslims introduced the jamdani style of weaving in Bengal. The claim seems probable in the sense that the Muslims held the monopoly of jamdani in Bengal for centuries both in its weaving and marketing. But Jamdani as a fabric is considered to be much older than Muslim rule in Bengal. The Arthasastra (about 300 AD) mentions Vanga to be the home of a very delicate textile staff.

Jamdani is also found in the book of Periplus of the Erythraean Sea and in the accounts of Arab, Chinese and Italian travelers and traders. Four kinds of fine cloths were produced in Vanga and Pundra in those days, viz *khouma*, *dukul*, *pattrorna* and *karpasi*.

The art of making jamdani designs on fine fabric reached its zenith during Mughal rule. There were handlooms in almost all villages of dhaka district. Dhaka, Sonargaon, Dhamrai, Titabari, Jangalbari and Bajitpur were famous place for making superior quality jamdani and muslin. Traders from Europe, Iran, Armenia, and later USA came to Bengal to buy Bengal muslins. The Mughal Emperor, the Nawab of Bengal and other aristocrats used to engage agents at Dhaka to procure muslin and jamdani fabrics for royal families.

According to a record of mid-19th century, the rulers and nawabs of Delhi, Lucknow, Nepal and Murshidabad used to wear white muslin with floral jamdani designs costing Rs 50,000. A number

of causes are responsible for the decline of the jamdani and muslin industry from the 1830s. The major factors were the industrial revolution in Britain, collapse of the Mughal aristocracies, and the rise of new markets for cheaper textiles. However, now the Bangladesh government is giving

support to the development jamdani industry in its modern perspectives.



Weaving technique

The mastery of muslin cloth weaving used to depend usually on the art of making yarns. The most appropriate time for making yarns was early morning as the air then carried the highest moisture. For making yarns weavers needed *taku*, a bamboo basket, a shell and a stone cup. They used popcorn, rice or barley for starch. Before making jamdani designs they used to dye their yarn and starch it. For dye they used flowers and leaves of creepers. For quality jamdani they used yarn of 200 to 250 counts. These days' weavers buy fine yarn from the market and use chemical dyes instead of herbal dyes. For making jamdani two weavers sit side by side at a loom to work on the delicate designs. Jamdani designs are made while

the fabric is still on the loom. Coarse yarns are used for designs to make the motifs rise above the fabric. Originally, the motifs used to be made on gray fabric. Later on fabrics of other colours were also used. In the 1960s, jamdani work on red fabric became very popular.

Variety of jamdani work

The most particular characteristic of jamdani work is its geometric design. The expert weavers do not need to draw the design on paper. They do it from their instinct. Jamdanis have different names according to their design. Some names of jamdani are: *panna hajar*, *dubli jal*, *butidar*, *tersa*, *jalar*, *duria*, *charkona*, *mayur pyanch*, *kalmilata*, *puilata*, *kachupata*, *katihar*, *kalka pad*, *angurlata*, *sandesh pad*, *prajapati pad*, *durba pad shaplaful*, *baghnali*, *juibuti*, *shal pad*, *chandra pad*, *chandrahara*, *hansa*, *jhumka*, *kauar thyanga pad chalta pad*, *inchi pad*, *bilai adakul naksha*, *kachupata pad*, *badghat pad*, *karlapad*, *gila pad*, *kalasful*, *murali jal*, *kachi pad*, *mihin pad*, *kankra pad*, *shamukbuti*, *prajapati buti*, *belpata pad*, *jabaful* and *badur pakhi pad*. Present day jamdani

saris have on their background designs of rose, jasmine, lotus, bunch of bananas, bunch of ginger and sago.

Efforts are underway to revive traditional jamdani designs. A jamdani with small flowers diapered on the fabric is known as *butidar*. If these flowers are arranged in reclined position it is called *tersa jamdani*. It is not necessary that these designs ought to be of flowers only. There can be designs with peacocks and leaves of creepers. If such designs cover the entire field of the sari it is called *jalar naksha*. If the field is covered with rows of flowers it is known as *fulwar jamdani*. *Duria jamdani* has designs of spots all over. *Belwari jamdani* with colourful golden borders used to be made during the Mughal period, especially for the women of *herem*, the inner court.

The jamdani of Dhaka still survives with its new characteristics. It needs one to two months to make a standard jamdani sari. Although jamdani was made in different parts of Bangladesh in the past, the core villages to weave it were the villages which still survive with their past glories. The weavers of these villages are the main descendants of traditional jamdani weavers. The sites are Noapara, Dakkhin Ruposhi, Ruposhi Kajipara, Gandabpur, Shiddhirgonj, Mugrakul, Khidirpur, Imkoli, Tarabo, Khalpara, Dighborar, Khadun, Pabankul and Sultanbagh, Moreover, jamdani is also made by the artisan of nearby villages of Gonganagar, Kahina, Meergodai, Mahimpur, Harina Nodir Par and Meerkutircheo, and some areas of Sonargaon upazila. At present, Jamdani is also produced in Boalmari upazila of Faridpur district.

(*Banglapedia*)

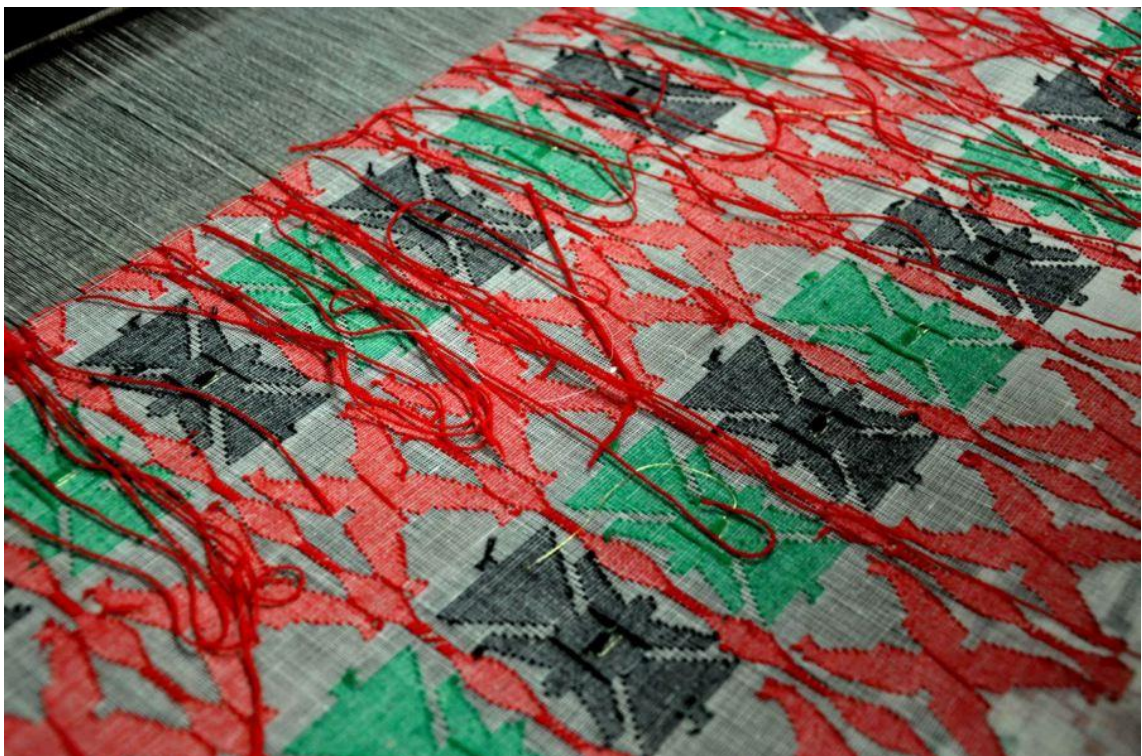

3.5.2 - Benarasi

The heritage of woven handloom silk in Bengal does not compare to the fine cotton muslins in terms of historic or chronological measurement.

Silk textiles were available in the last few hundred years from China and other parts of the Indian subcontinent and were used by the aristocracy



and landed classes for ceremonies, coronations and weddings. The use of silk for garments has become more popular in the recent fifty years or so.

The culture of the Indo-Gangetic plains has been nurtured by the mighty rivers Ganga and Jamuna. The soft breezes blowing out from the rivers were conducive to keeping the looms and the waft and weft of threads pliable. The romance of the soft pure silks of Banaras had reached Bengal with the advent of Moghul rule. By the 1920's the Banarasi sari became an essential part of the Indian bridal trousseau. The item was supplied as part of the exotic textiles from Uttar Pradesh, India.

By the 1930s Dhaka set up its own Banaras Silk Industry Centre in Becharam Dewry, in the old town. Sarees were priced at Rs. 150/- and a bridal saree fetched a princely price of Rs. 400/-. The main market outlets were in Sadarghat Market, Islampur of the old town and by the 1960s the posh newly built New Market near Nilkhet.

During partition in 1947 some 125 families migrated to Parbatipur of Rajshahi district and to various areas of Old Dhaka — Becharam Deuri, Kazi Alauddin Road, Kaiktuli, Tanti Bazar, Doyaganj and Gandaria from Benaras in India. And they brought along with them their skills of weaving the famous benarosi sari. After independence of Bangladesh, the artisans who were in Dhaka started to live in the refugee camps of Mirpur and made their living from weaving saris. Gradually their small handloom industry began to expand and so did the production. Sari making in Mirpur gradually grew into big industry from what was initially cottage industry. Towards the late nineties, a big market also grew up alongside the sari-making units in Mirpur. This is now known

as the Benarosi Palli. Though the craft of making Benarosi sari was brought in by non-Bengalis and they are the ones who knew this craft, gradually the number of Bengali artisans has also risen and at present the number of Bengali artisans is almost equal to those of non-Bengalis.

Names of tools used to weave Benaras silk brocades are as follows:

- Turai / belun (roller-beam)
- Khuta (side posts)
- Karga (pit)
- Lappa (horizontal wooden rods)
- Jacquard (cards perforated with holes for lifting needed threads)
- Phhana (bamboo read)
- Makri (upper/roof suspended rods)
- Gulla or baw of natawa bamboo/wood spool.
- Tana (steel plate)
- Rooler (wood roller)
- Charka (hand spin or cycle wheel)
- Khalli (iron rods rotated to tighten threads)
- Charr or birni (thin wire used to tighten threads).
- Makku or dherki (five inch long flat shuttle piece of buffalo horn used to push threads left or right as needed.
- Katha or shirki (wood or bamboo flat instrument used to form floral patterns). Nowadays these are made of plastic.

Weaving technique



1. First high quality silk threads are purchased at an approximate rate of Tk. 1,500 per kg imported from China, India, Pakistan or Thailand. These imported threads come in the form of bales and are put onto wood rollers.

2. From these smaller lengths are cut and taken to spin spools on

wooden charkas (wheels) for the baana (weft).

3. The larger spools, lachhis are then sent for dyeing. Special dyeing experts, do this by immersing the threads in boiling pots of soap water for at least one hour, before laying them out to dry. After boiling for over an hour with at least 4 bars of soap in water for a length of two saris, the bundle threads have to be washed in at least four pots of clean water mixed with a thread softener called khararee (digamen).

4. The dyed spools are put onto turai or beams, which look like large rolling pins called belun.

5. The required lengths of threads for the taana (warp) of one or two saris are straightened out and joined if necessary to achieve the required length. The silk threads are fine like hair and they are joined with a powder called madesun made from fine soft ashes (chhai).

6. Once the threads are arranged for the taana, they are fitted at the weaver's end of the loom by specialised craftsman, who are not the weavers. The taana-setter knows beforehand that the sari has three colours; for example the main ground colour (jomeen) will be black, the border (paar) and end piece (anchol) will be beige and motifs will be of cream shades. The weaver explains the design to the setter referring to patterns such as keridar (paisley) or phoolkoli or kangeevaran. The exchange of information is all verbal and there is no written code or guideline. The skills belong to the craftsman.

7. The dyeing process is fascinating, as 70 yards can be dyed at one time in three colours, for up to five saris with blouse pieces. This is done by using one colour dye up to a given measurement of the threads.

8. For the baana or weft, the loom setter uses the pareta a bamboo rolling pin also called natawa. The thread spools already prepared by the charka workers are kept on the earthen floor near the weaver.

Variety of Benarasi work



Benarasi brocades were woven with the help of jacquard system, depending on the skill of the weaver in line-by-line placement of patterns on the *taana* and *baana*. The paper drawing of the designs would be the guide for the weaver, a matter of extraordinary skill of eye and hand. The

master craftsman of Mirpur informed me that silk brocades carried names such as *beldar*, border designs, forms of creeper design; *belbuti*, diagonal floral styles and satin-but, thickly embroidered motifs in silk thread embossing. Classical motifs from the Persian storehouse of design were known as *jam-e-bahar* (trellis patterns) and *jam-e-var* (Persian paisley) *gul-dasta* (bouquet or flower vase motif) also referred to as ambros. An overall linear floral ornamentation was called *jungala* (foliage pattern).

As time passed Bengali words came into use such as *lata-pata* (trellis) *prianka* (floral) *tara-but* (star bud) *kalka* (paisley), *moyur-pakhee* (peacock), *tiapakhee* (parrot). In recent years the influence of film and television media led to naming sari designs after Titanic, Devdas, and Ghar Ghar Ki Kahani. The weavers of Mirpur Palli were commissioned to produce the extravaganza of silk saris worn by Indian actress Aishwarya Rai and her dance troupe in the film Devdas.

As is common with most heritage crafts and arts produced in the subcontinent, the Benarosi loom is composed of wooden, bamboo and small metal parts arranged in the earthen pit floor of the Karkhana (factory). There has been no change in the loom since over a thousand years, the only change has been the addition of the jacquard introduced after 1947.

(*Banglapedia ; Bangladesh Cotton and Textile Convention, 2006*)

3.5.3 - Khadi

Khadi or khaddar is a material that involves the spinning of cotton manually by hand into yarns for the production of handwoven cotton weaves.

The weaves of Comilla during the Mughal period were renowned as valuable textiles with distinctive characteristics. In 1890 the Tripura Gazetteer reported accounts on the textiles and the weavers of Comilla. The articles made clear reference to the high quality sari, dhoti, lungi and gamcha produced with locally spun yarns and weaves.

During the years of the selfrule movement and later with the independence of Bangladesh the spirit of khadi was driven with the winds of



change. In Comilla the weaving centers were particularly developed in Moinamoti, Muradnagor, Gouripur and Chandina.

In 1921 Gandhi came to Chandina to inspire the local weavers and consequently a branch of 'Nikhil Bharat Tantubai Samity' was established here to self seed and proliferate the sale of goods to other major cities in India. The exceptional khadis were en route to Mumbai, Chennai and Kolkata.

Subsequently after the language movement in 1952 Dr. Akhtar Hamid Khan and Governor Firoz Khan Noon established 'The Khadi and Cottage Industry Association'. In 1957 Dr. Hamid Khan arranged to bring a khadi specialist from India to train and incorporate quality to the khadi. 400 'Ambar Charkas' were imported to assist the development efforts.



Simultaneously, Shoilan Guha took major steps to support the plight of the khadi industry in Chandina. His various initiatives and entrepreneurship energised the khadi production and large quantities were exported to Kolkata.

3.5.4 – Nakshi Kantha

Nakshi kantha, a type of embroidered quilt, is a centuries-old Bengali art tradition of Bangladesh. The basic material used is thread and old cloth. Kanthas are made throughout Bangladesh, but the greater Mymensingh, Rajshahi, Faridpur and Jessore areas are most famous for this craft.

The colorful patterns and designs that are embroidered resulted in the name "Nakshi Kantha", which was derived from the Bengali word "naksha", which refers to artistic patterns. The early kanthas had a white background accented with red, blue and black embroidery; later yellow, green, pink and other colors were also included. The running stitch called "kantha stitch" is the main stitch used for the purpose. Traditionally, kantha was produced for the use of the family. Today, after the revival of the nakshi kantha, they are produced commercially.

Weaving Technique

Traditionally old sarees, lungis and dhotis were used to make kanthas. Kantha making was not a full-time job. Women in almost every household were expert in the art. Rural women worked at leisure time or during the lazy days of the rainy season, so taking months or even years to finish a kantha was normal. At least five to seven sarees were needed to make a standard-size kantha.



Today the old materials are replaced by new cotton cloths. Traditionally the thread was collected from the old sarees. That is rarely done today.

When a kantha is being made, first the sarees are joined together to attain the required size, and then layers are spread out on the ground. The cloths are then smoothed, and

no folds or creases are left in between. During the process, the cloth is kept flat on the ground with weights on the edges. Then the four edges are stitched and two or three rows of large running stitches are done to keep the kantha together. At this stage, the kantha can be folded and stitched at leisure time.

Originally, designs and motifs were not drawn on the cloth. The design was first outlined with needle and thread, followed by focal points, and then the filling motifs were done. In a kantha with a predominant central motif the centre was done first, followed by corner designs and the other details. In some types of kanthas (carpet, lik and sujni, etc.) wooden blocks were used to print the outline. The blocks are replaced today by patterns drawn in tracing papers.

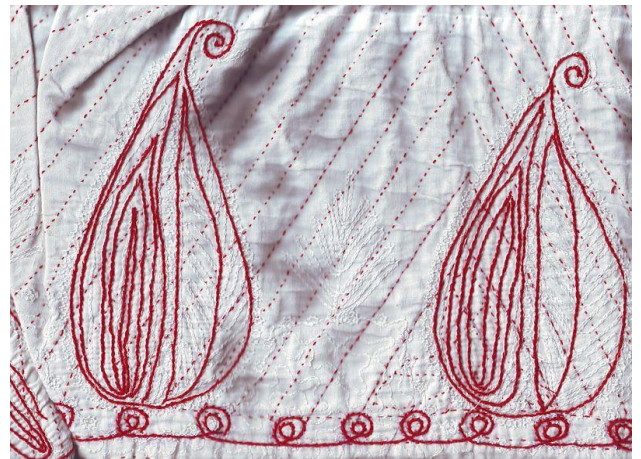

Variety of Nakshi Kantha

Running stitch

The Running stitch kantha is truly the indigenous kantha. They are subdivided into Nakshi (figured) and par tola (patterned). Nakshi (figured) kanthas are further divided into motif or scenic kanthas.

- Lohori kantha

The name was derived from Persian word 'lehr', which means wave. This type of kantha is particularly popular in Rajshahi. These kanthas are further divided into soja (straight or simple), Kautar khupi (pigeon coop or triangle), borfi or diamond (charchala, atchala or barachala).

- Lik or anarasi

The Lik or Anarasi (pine apple) type of kantha is found in the Chapainawabgonj and Jessore areas. The variations are lik tan, lik tile, lik jhumka, and lik lohori.

- Cross stitch or carpet

This type of kantha was introduced by the English during the British Rule in India. The stitch employed in these kanthas is the cross stitch.

- Sujni kantha

This type of kantha is found only in Rajshahi area. The popular motif used is the undulating floral and vine motif.



Variety of Motifs and Borders used in Nakshi Kantha

Motifs of the nakshi kantha are deeply influenced by religious belief and culture. Even though no specific strict symmetry is followed, a finely embroidered nakshi kantha will always have a focal point. Most kanthas will have a lotus as focal point, and around the lotus there are often undulating vines or floral motifs, or a shari border motif. The motifs may include images of flower and leaves, birds and fish, animals, kitchen forms even toilet articles.

While most kantas have some initial pattern, no two nakshi kantas are same. While traditional motifs are repeated, the individual touch is used in the variety of stitches, colours and shapes. The notable motifs found in nakshi kantha are as follows:

- Lotus motif
- Solar motif
- Moon motif
- Wheel motif
- Swastika motif
- Tree of life motif
- Kalka motif

Most nakshi kanthas have some kind of border. Either a sari border is stitched on or a border pattern is embroidered around the kantha. The common border found in kanthas are as follows

- The Paddy stalk or date branch (dhaner shish or khejur chari)
- The Scorpion border (Biche par in Bengali)
- The Wavy or bent Border (Beki in Bengali)
- The Diamond border (Barfi)
- The Eye border (chok par in Bengali)
- The Amulet border (Taabiz par in Bengali)
- The Necklace border (mala par in Bengali)
- The Ladder Border (Moi taga)
- The Gut taga
- The Chick taga
- The nolok taga
- The Fish border (Maach par in Bengali)
- The panch taga
- The Bisa taga
- The Anaj taga
- The shamuk taga
- The wrench border
- The anchor (grafi par in Bengali)
- The pen border (kalam par in Bengali)

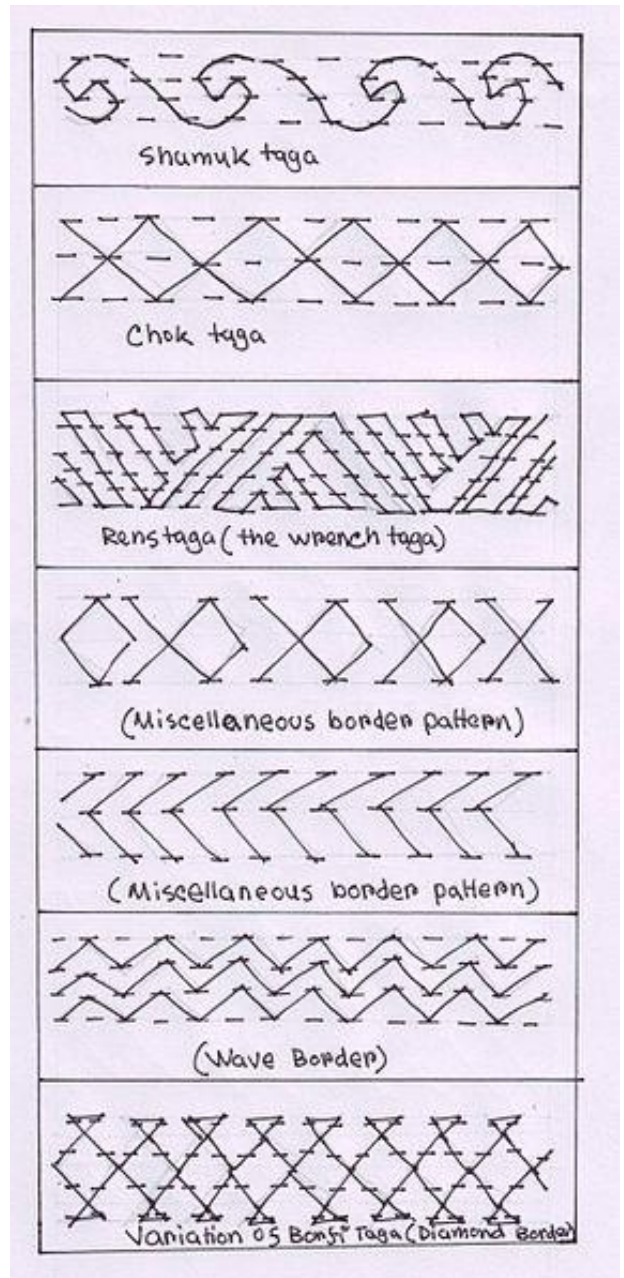

Fig 17: Border motifs of NakshiKantha

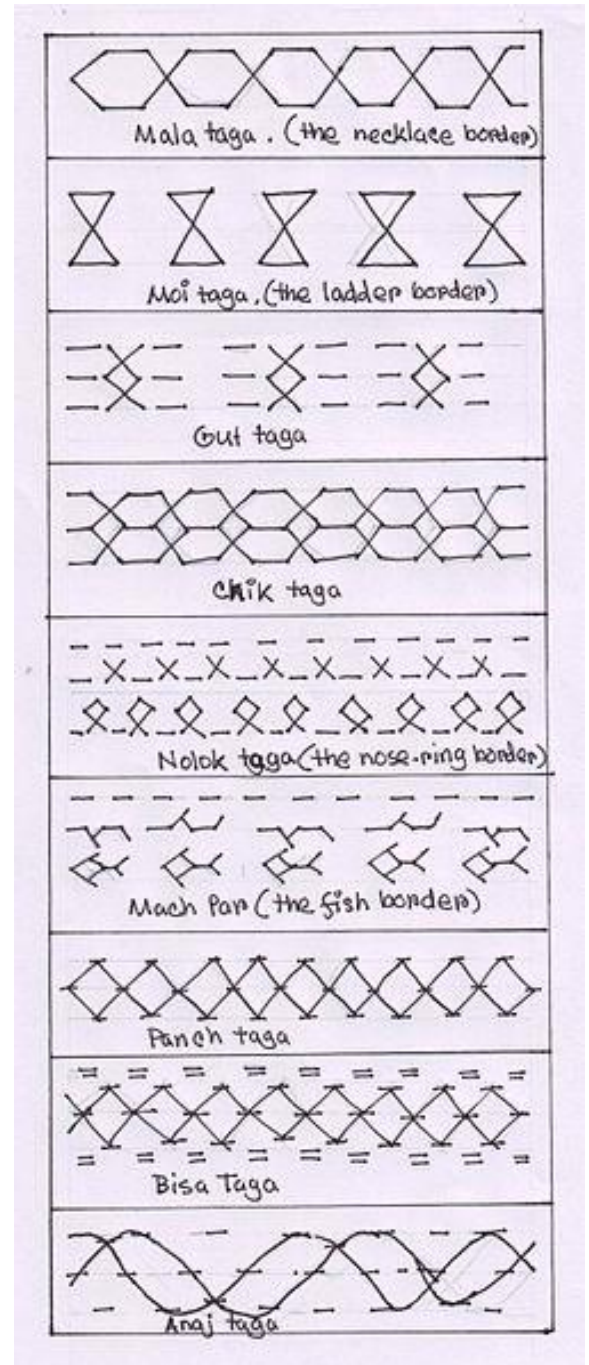
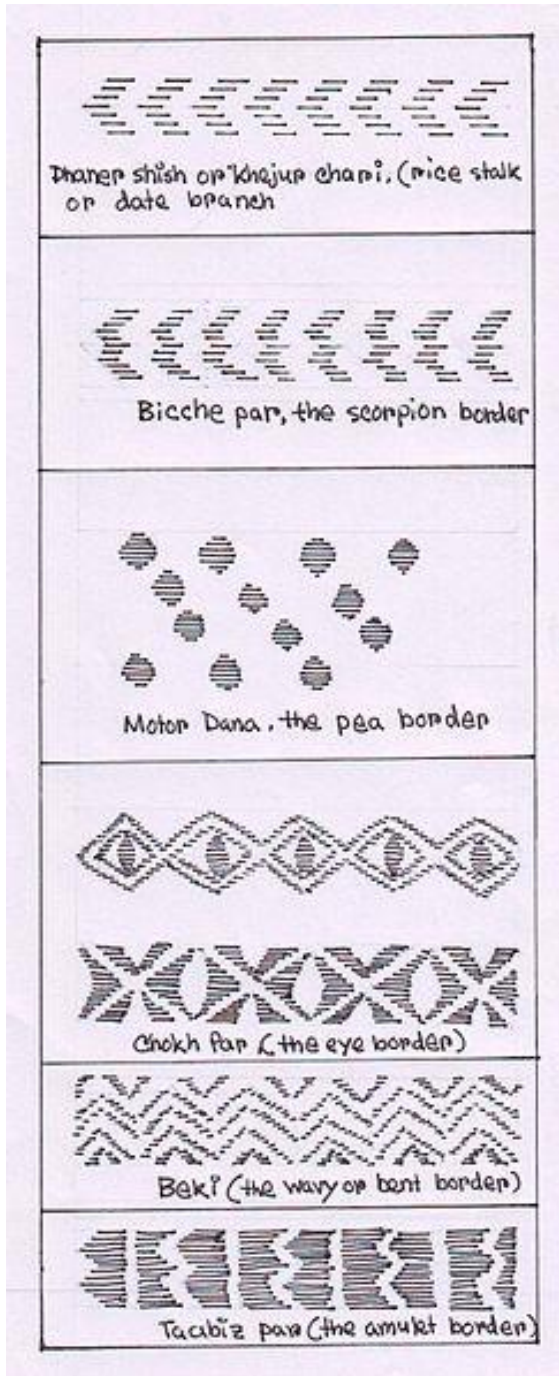

Fig 17a: Border motifs of Nakshi Kantha

3.5.5 - Tribal Textiles

The Tribals of the Chittagong Hill Tracts consist of ten main tribes, belonging to the Chakma, Tripura, Tonchangya, Roeng, Pangué, Tusha, Moru, Khumi, Chak and Khyeyng. Several, but not all of these tribes had a weaving tradition. The Chakmas, an important tribe, who follow Buddhism, produce handloom cloth, which carries an ancient link with tribal or indigenous communities in larger Asia. Weaving in Buddhist tradition holds spiritual and ritualistic overtones. In fact some textiles are considered as sacred, such as those woven to commemorate the death of a person and also those woven for marriage ceremonies. There is a special cloth made of hand spun yarn and woven specially as an act of charity. Such long pieces of fabric are made by Chakma women and hung out in open spaces or forest areas on a tall bamboo, as a gift to the monks. Buddhist monks eat from charity (they do not cook their own food) and also they cannot purchase their garments. They receive gifts of their robes from the community, who hang the material in the open, and any monk whose clothes have worn out can cut off a piece to fulfill the needs of his apparel.

The weaving of material for charity in olden times was a religious act, and the raw materials were made of handspun cotton thread, natural dyes. Ritual prayers are offered at the time of weaving.



The Chakma Loom:

The most well-known loom is called Baen. It has twelve main parts, nearly all made from bamboo and the chhaw betal nut tree. The parts are as follows:

Biyong, Bau Kati - heel section, Shaugtia bach, Siyang - to keep threads uniform, Tammo bach - beam, Tagalog - beam, Leblebi - heel to set threads of taana, Thur Sama - shuttle of bamboo, Charka - spinning wheel, Chorki - for spinning jhoom threads, Tarchi Cam - Waist belt (of buffalo hide), Rope - for belt and Tarchidori.

Names of Designs:

Every Chakma girl is taught weaving by her mother and elders. The skill is considered a qualification of a good wife and mother and a spiritual value is given to the art of weaving.

At about eight years of age a girl is encouraged to start learning a range of designs, which her mother shows her from an heir-loom woven catalogue. This is called the aalum.

There are hundreds of patterns but a good weaver must learn. Some of the most famous designs are:

1. Begum bichi - seed of eggplant.
2. Teen beya - three sticks used to hold threads.
3. Kanjal - snake curve.
4. Bangal Chabugi - small flower.
5. Bago choke - tiger's eye.
6. Chori phool - design on clay water pot.
7. Anaj - pineapple.
8. Tuptupi - aat-bo-lizard's foot.
9. Bourgogaw - like Bangla alphabet letter.
10. Padi cabang gach - king of design.
11. Aza thang - ducks feet.
12. Chaba Kangel - snake twist.
13. Satacrang - small wild marigold.
14. Thengbala satarang - combined pattern.
15. Majara - cane stool design.
16. Kangara - crab.
17. Sath beya karanga kapya - seven stick.
18. Daush beya - 10 sticks.

(Bangladesh Cotton and Textile Convention, 2006)

3.6 Present Scenario of Handloom Industry

3.6.1 - Important Products with Places of Production

Sl.	Name of the Products	Place of Production
1	Jamdani	Rupgonj and Sonargaon of Narayangonj district.
2	Benarasi	Mirpur of Dhaka, Iswardi of Pabna district and Gangachara of Rangpur district.
3	Tangail Sharee (Cotton sharee, Half Silk, Soft Silk, Cotton Jamdani, Gas-mercerised twisted cotton sharee, Dangoo sharee, Balucherri)	Tangail Sadar, Delduar and Kalihati, Nagorpur, Basail of Tangail District.
4	Handloom Cotton share	Shahjadpur, Belkuchi and Sadar of Sirajgonj district, Narsingdi and Pabna districts.
5	Lungi	Ruhitpur of Keranigonj and Dohar of Dhaka district, Shahjadpur, Ullapara, Belkuchi, Sadar of Sirajgonj district, Kumarkhali of Kushtia district, Sathia,
6	Silk share	Sadar and Shibgonj of Chapai Nawabgonj and Rajshahi district.
7	Gamcha	Ullapara, Kamarkhand of Serajgonj, Gouranadi of Barisal, Fultola, Doulatpur of Khulna, Jhalokathi, Jessore and Bogra districts.
8	Check Fabrics	Belkuchi of Sirajgonj district.
9	Mosquito Nets	Araihazar and Rupgonj of narayangonj district, Shibpur and Sadar of Narsingdi district.
10	Bed Sheet & Bed Cover	Kumarkhali of Kustia district, Danga of Narsingdi district.
11	Sofa Cover	Danga of Narsingdi district.

12	Rakhine Special Wear(Wooling Shirting, Woolen Bed Sheet, ladies chadar, Bag,Lungi and Thami for tribal ladies)	Taltoli of Borguna district, Kalapara, Rangabali of Patuakhali district and Cox's Bazar district.
13	Tribal Fashion Wear (Thami for tribal ladies, Khati(Orna), Ladies Chadar & Lungi.	Rangamati, Khagrachari & Bandarban Hill districts.
14	Miniouri Fashion Garments (Monipuri Sharee, Puneek for ladies like lungi, Lungi, Un-stitched cloth (three pieces), Innachi(Orna) & Vanity Bag	Sylhet and Moulivibazar districts.

3.6.2 – Current Statistics

Items	Number
Total Handloom units	183512
Total number of handlooms	505556
Total number of operational looms	313245
Total number of nonoperational looms	192311
Type wise number of looms Pit loom	169700
Frame loom	29212
Waist loom	141684
Semi-automatic/ Chittaranjan loom	150407
Benarashi/ Jamdani	12383
Others	2170
Number of Weavers	Number
Total number of weavers	888115
Total number of male weavers	472367
Total number of female weavers	415748
Handloom Factory (As of May 2008)	Number
Number of Handloom factory registered with the BHB (Factory is a production unit having more than 20 looms)	246

Source: Bangladesh Handloom Board

3.6.3 - Distribution of Looms by Type

There are mainly six types of looms in Bangladesh. They are pit loom, frame loom, Chittarangan loom, Benarasi or Jamdani loom, Komar or waist loom and power loom in Bangladesh. The distribution of total looms and operational looms by type are shown below Table 1.

Table 1 : Distribution of Looms by Type

Type of Looms	Total looms	Operational	Percent
Pit Loom	169700	107066	63.1
Frame Loom	2212	18410	63.0
Chittarangan Loom	150407	105410	70.1
Banarasi/Jamdani Loom	12383	9997	80.7
Komar/waist Loom	141684	69588	49.1
Power loom	2170	1380	63.6
Total Loom	505556	311851	61.6

Source: Handloom Census, 2003

3.6.4 - Handloom Concentrated Districts

Handloom industry did not develop equally in all regions of Bangladesh. This industry is concentrated historically in some regions with availability of inputs, marketing and transportation facilities. The following table describes the concentrated areas of handloom weaving industries in Bangladesh.

Table 2: Ranking of Districts by Handloom

District	2003		Ranking
	Establishments	Looms	
Sirajgang	14870	143858	1
Tangail	6476	37222	2
Pabna	7434	35119	3
Narsingdhi	7247	26693	4
Kushtia	11927	22348	5
Narayangan	5178	14743	6
Dhaka	5448	13604	7
Brahmanbaria	3944	10505	8
Bogra	3877	5446	9
Comilla	3090	4696	10
Total	69491(37.9)	314234(62.2)	

Source: Handloom Census, 2003

Note: The table excludes handloom establishments and looms in Chittagong and the figure in bracket of the last row shows the Percent of Bangladesh.

From Table 2, it is observed that excluding those of Chittagong, Sirajgang District has the highest number of establishments 14,870 in 2003 with corresponding looms 143858. By ranking in terms of number of looms from top to below in 2003, the other Districts are Tangail, Pabna,

Narsingdi, Kushtia, Narayangang, Dhaka, Brahmanbaria, Bogra and Comilla with looms respectively 37,222, 35119, 26693, 22348, 14743, 13604, 10505, 5446 and 4696. A similar ordering of Districts in terms of looms per unit almost gives the same result. There are 37.9% of establishments and 62.2 % of operational looms of total establishments and looms in above-mentioned Districts.

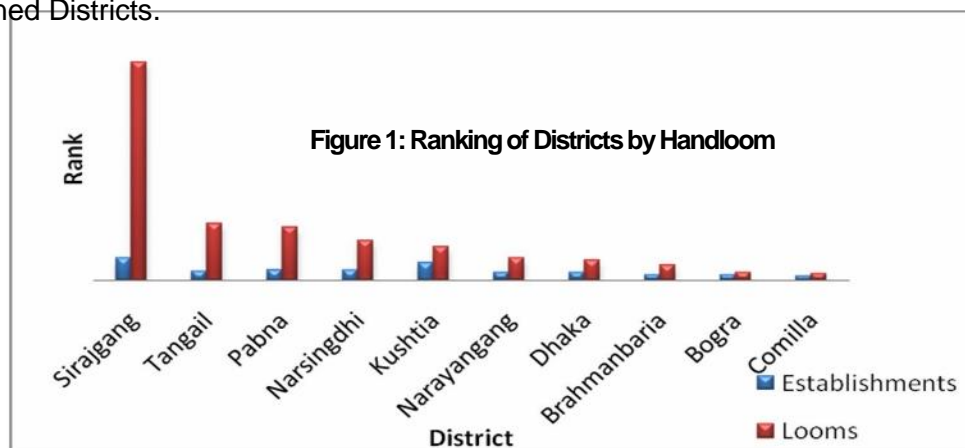

Fig 18: shows the rank of districts by handloom weaving industries in Bangladesh. The figure indicates that Sirajgang District has the highest number of establishments.

3.6.5 - Problems of Handloom Industry

Handloom industry has been recognized as the prominent industry and it has been called the backbone of our agricultural economy. It can be recognized as the mainstay of the weaving industry for supply of bulk of the domestic cloth requirements.

From a study conducted by Elias Hossain and Khairul Islam of Rajshahi University, it is found that the handloom sector is raising rural employment and income, alleviating rural poverty, bringing equity in the distribution of income, substituting imports, and increasing potentials for exports.

However, this industry has some inherent problems. These are inadequate supply of yarn and dyes, high price of raw materials, lack of institutional credit, marketing problem, unfair competition, lake of efforts for improvement, lack of product diversification and organizational Problem. Due to these problems, many handloom units are remaining non-operational at present. Bangladesh Handloom Census-2003 identified the reasons for non-operation of looms. That reasons have been presented in Table 3.

Table 3: Reasons for Non-operation of Looms

Reasons for non-operation of loom	Frequency, <u>2003</u>	Percentage, <u>2003</u>	Frequency, <u>1990</u>	Percentage, <u>1990</u>
Lack of capital	75511	79	123597	80
Lack of yarn	11566	12	12284	8
Labor problem	1865	2	2334	2
Sale problem	4931	5	5860	4
Others	1509	2	10220	6
<u>Total reporting units</u>	<u>95382</u>	<u>100</u>	<u>154295</u>	<u>10</u>

Source: Handloom Census, 2003

3.7 Ergonomics Standard Study for Project Related Spaces

3.7.1 Library

TABLE 2 Guidelines for Determining Minimum Space Requirements

Population served	Shelving Space*			Reader space, sq ft	Staff work space, sq ft	Estimated additional space needed, sq ft‡	Total floor space, sq ft
	Size of book collection, volumes	Linear feet of shelving†	Amount of floor space, sq ft				
Under 2,499	10,000	1,300	1,000	Min. 400 for 13 seats, at 30 sq ft per reader space	300	300	2,000
2,500-4,999	10,000, plus 3 per capita for pop. over 3,500	1,300. Add 1 ft of shelving for every 8 vols. over 10,000	1,000. Add 1 sq ft for every 10 vols. over 10,000	Min. 500 for 16 seats. Add 5 seats per 1,000 over 3,500 pop. served, at 30 sq ft per reader space	300	700	2,500, or 0.7 sq ft per capita, whichever is greater
5,000-9,999	15,000, plus 2 per capita for pop. over 5,000	1,875. Add 1 ft of shelving for every 8 vols. over 15,000	1,500. Add 1 sq ft for every 10 vols. over 15,000	Min. 700 for 23 seats. Add 4 seats per 1,000 over 5,000 pop. served, at 30 sq ft per reader space	500. Add 150 sq ft for each full-time staff member over 3	1,000	3,500, or 0.7 sq ft per capita, whichever is greater
10,000-24,999	20,000, plus 2 per capita for pop. over 10,000	2,500. Add 1 ft of shelving for every 8 vols. over 20,000	2,000. Add 1 sq ft for every 10 vols. over 20,000	Min. 1,200 for 40 seats. Add 4 seats per 1,000 over 10,000 pop. served, at 30 sq ft per reader space	1,000. Add 150 sq ft for each full-time staff member over 7	1,800	7,000, or 0.7 sq ft per capita, whichever is greater
25,000-49,999	50,000 plus 2 per capita for pop. over 25,000	6,300. Add 1 ft of shelving for every 8 vols. over 50,000	5,000. Add 1 sq ft for every 10 vols. over 50,000	Min. 2,250 for 75 seats. Add 3 seats per 1,000 over 25,000 pop. served, at 30 sq ft per reader space	1,500. Add 150 sq ft for each full-time staff member over 13	5,250	15,000, or 0.6 sq ft per capita, whichever is greater

SOURCE: American Library Association, Subcommittee on Standards for Small Libraries, Public Library Association, Interim Standards for Small Public Libraries: Guidelines Toward Achieving the Goals of Public Library Service (Chicago: The Association, 1962), p. 15. This brief 16-page report is based on standards set forth in ALA's, Public Library Service; A Guide to Evaluation with Minimum Standards. It is intended to provide interim standards for libraries serving populations of less than 50,000 until these libraries can meet the standards of ALA's Public Library Service.

*Libraries in systems need only to provide shelving for basic collection plus number of books on loan from resource center at any one time.

†A standard library shelf equals 3 lin ft.

‡Space for circulation desk, heating and cooling equipment, multipurpose room, stairways, supplies, toilets, etc., as required by community needs and the program of library services.

Fig 19: Guidelines for determining minimum space requirement for Library

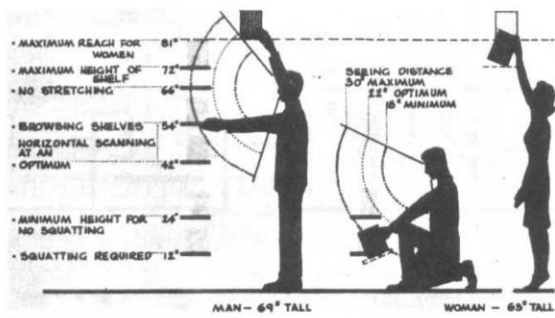

Fig. 1 Optimum shelving conditions for adults.

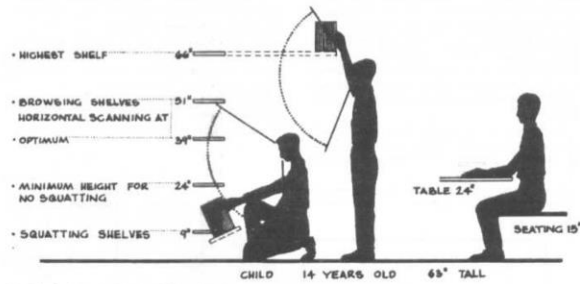

Fig. 2 Optimum shelving conditions for teenagers.

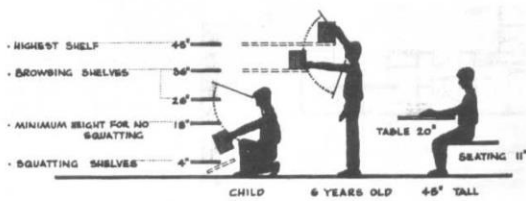

Fig. 3 Optimum shelving conditions for children.

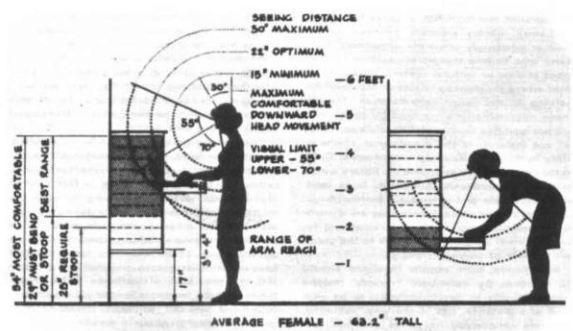

Fig. 7 Desirable heights for catalog tray consultation.

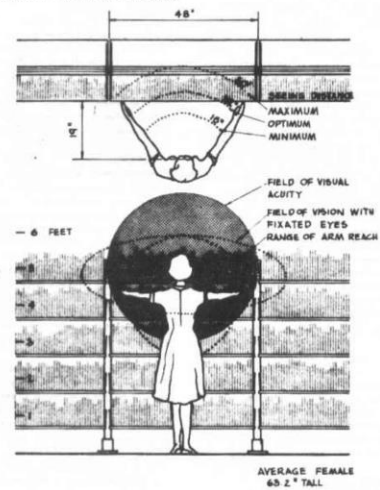

Fig. 8 Study for feasibility of scanning the 48-in. shelf.

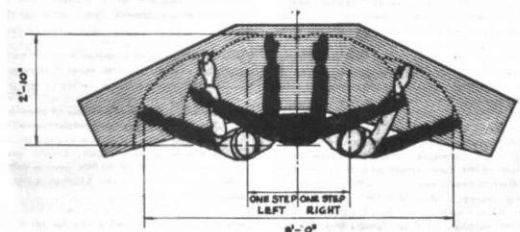

Fig. 9 Study for charge desk - maximum usable space from one position or station.

3.7.2 Museum

Functions	Space required
1. Curatorial Functions	
a. Collection, preservation, identification, documentation, study, restoration.	a. Office-workroom, Workshop
b. Storage of collections.	b. Reserve Collection Room
2. Display Function	
Thematic and changing displays of selected objects and documents from the collections arranged to tell a story.	Display Gallery
3. Display Preparation Function	
The preparation of exhibits.	Workshop, Office-workroom
4. Educational and Public Functions	
This term has been expanded to include all public functions.	
a. Lectures, school tours, society meetings, films, and social functions.	a. Lecture room, Chair storage closet, Kitchenette
b. Reception, information, sales, supervision of display gallery.	b. Lobby Sales and Information Counter
c. Public requirements.	c. Cloak room, Washrooms
5. Other Services	
a. Mechanical.	a. Heating-ventilation plant
b. Janitorial.	b. Janitor's closet

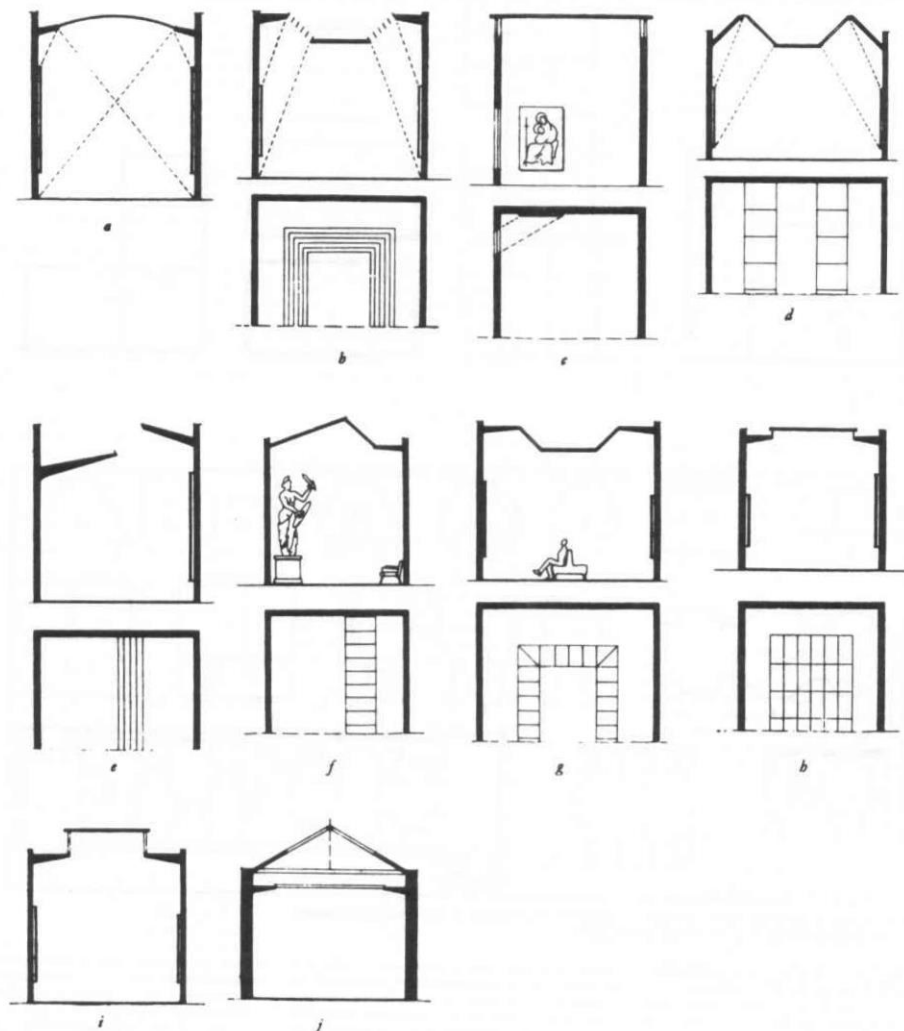

Fig. 1 Different methods of admitting natural light from above. (a) Cross section. (b) to (h) Cross section and view from above. (i) and (j) Cross section.

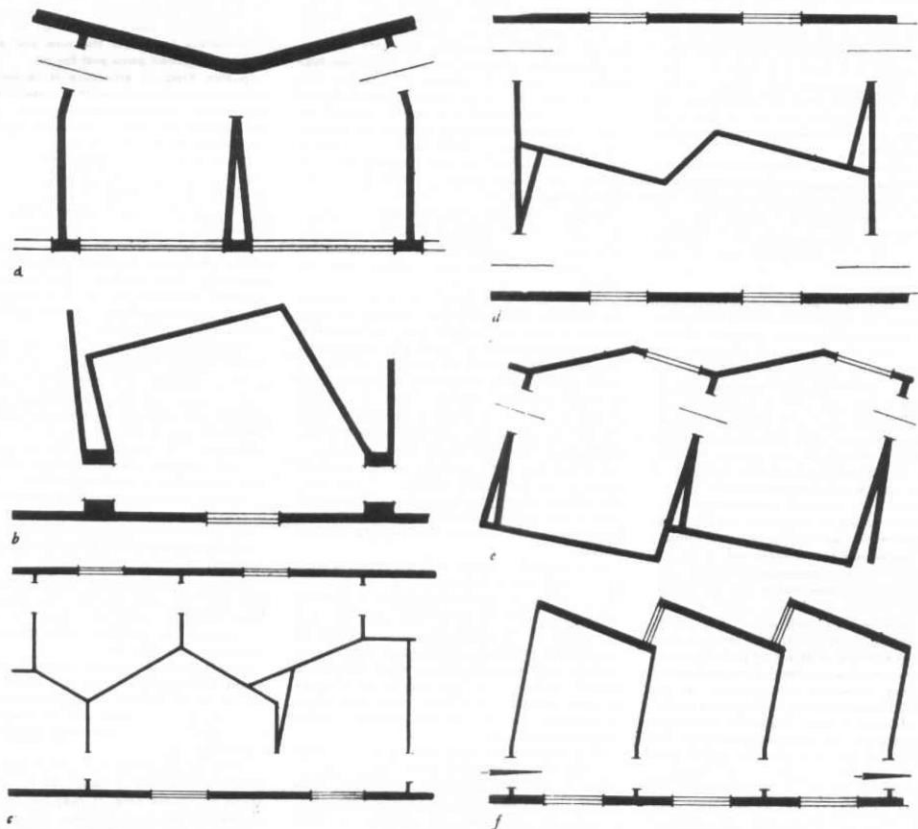
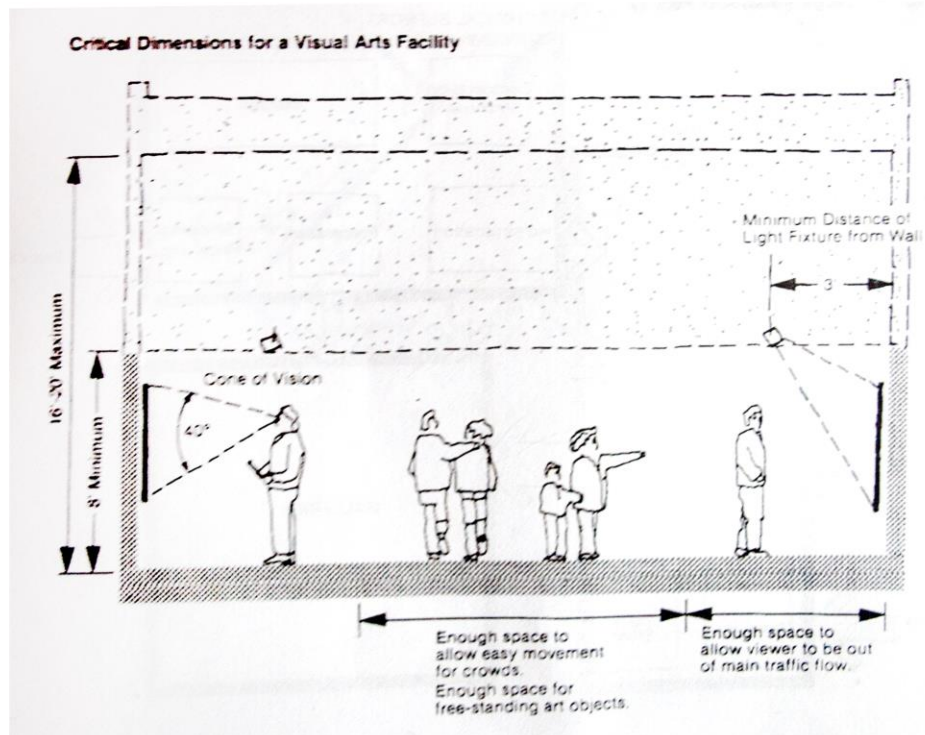

Fig. 4 Different ways of dividing up exhibition space.



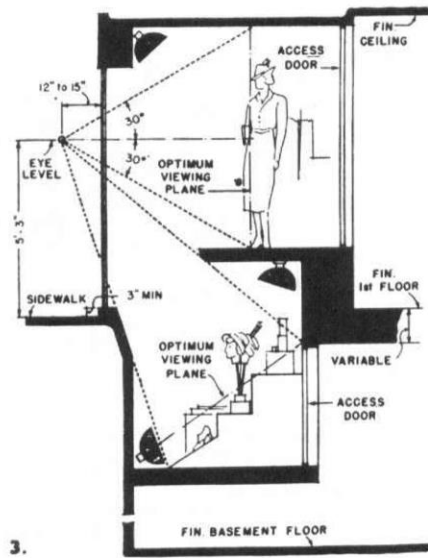
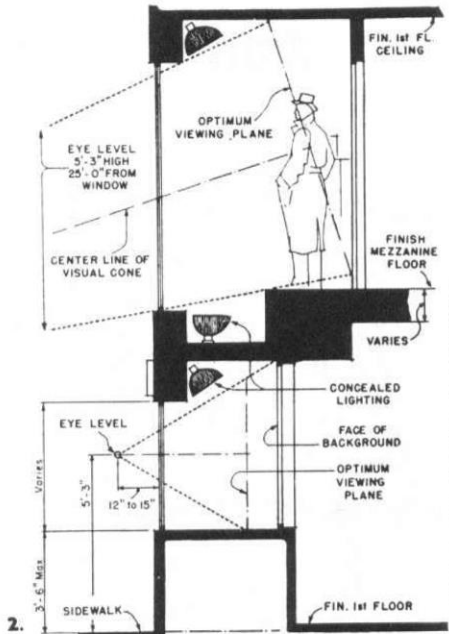
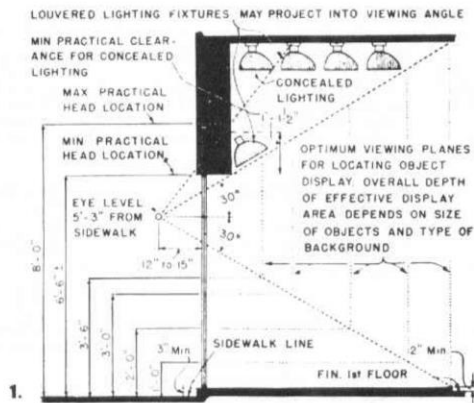

Fig. 5 Determining optimum show-window depths. Within a 60° cone, the average human eye sees comfortably, without appreciable physical effort. Optimum viewing planes are those in which objects on display can be seen in their entirety without causing the eye to encompass arcs greater than 60°. Diagram 1 illustrates a graphic method of determining optimum viewing planes for given bulkhead heights. Diagram 2 shows the application of these principles to second-floor windows; sight lines are limited by practicable window dimensions. Diagram 3 extends basic principles to include both basement and first-floor levels, seen through one window.

Chapter 4: Case Studies

4.1 Kolkata Museum of Modern Art

4.2 GC Prostho Museum & Research Center

4.3 Museum of Handcraft Paper

4.1 Case Study 01

Project Name: Kolkata Museum of Modern Art

Location: Rajarhat, Kolkata, India

Architect: Herzog & de Meuron

Project Area: 50000 sqm / 12.3 acre

4.1.1 Introduction



The Kolkata Museum of Modern Art (KMOMA) seeks to embrace the city's renowned cultural past and ultimately transform it into India's "Art City". Programs ranging from high-end gallery and art restoration facilities, to artist studios and an outdoor performance theater aims to empower local artists so they may play a critical role in the evolution of their community.

KMOMA will expand the multiple functions that support a traditional contemporary museum to provide a platform for artists, scholars, students and visitors alike to have an enhanced experience of the critical role art and museums play in the community.

4.1.2 Site

Kolkata has long been recognized as one of India's key cultural centers. From its time as the capital of the British Empire in India to its current modern era, the city has been home to a diverse group of key personalities, iconoclastic ideas and revolutionary trends instrumental in shaping the social, artistic and literary landscape of contemporary India.

A city with a tradition of folk and popular art, Kolkata was also the site of India's first School of Art in the mid-nineteenth century. At the heart of India's avant-garde in the colonial and post-colonial eras, the School and the city became a laboratory of ideas and techniques that coupled Indian and Western art practices and played a formative role in the development of Indian Modernism.

This artistic legacy continues to this day, with Kolkata continuing its role as a center for contemporary art production.

The site for the new building is situated in Rajarhat, a new commercial, industrial and residential district on the north-eastern fringes of Kolkata, building on the Old City and Salt Lake City from the nineteenth and twentieth Centuries respectively. It is one of India's fastest growing cities and is destined to become a vibrant hub in Kolkata with an increased presence of cultural activity.



4.1.3 Program and Concept

The concept envisions a collection of simple rectilinear volumes of urban and monumental scale, arranged to express the complexity and diversity of the program. It draws on traditional Indian construction principles of stacking individual elements, producing a coherent and legible whole through the collection and compression of diverse, unique elements. These elements appear as strata in the façade of the volumes and reflect the simplicity with which they will be built. At the east and south entrances to the site, volumes and voids create courtyards, streets, alleyways and market-like experiences which lead the visitor into a central plaza, a place for gathering and orientation. At the west end of the plaza, the museum rises in a vertical stack of volumes asserting a presence within the complex and the greater urban context. Punctuated throughout the complex are a series of public spaces connected by a network of generous staircases carving out the exterior and interior of the building. The assembly of different program, scales and qualities

throughout the site gives the proposal a city-like quality, The new Kolkata Museum of Modern art recognizes the importance of public space in India and offers visitors many opportunities for discovery and interaction within a diversity of spaces.

The fifty thousand square meters of program is divided into two equal zones: a museum containing galleries, art restoration, education, research facilities, photographic facilities, offices and theatre; and a 'Culture City' containing dining and event spaces, commercial facilities, artist studios and residences, spaces for the sale of art and crafts, outdoor performance space, public space and car parking.

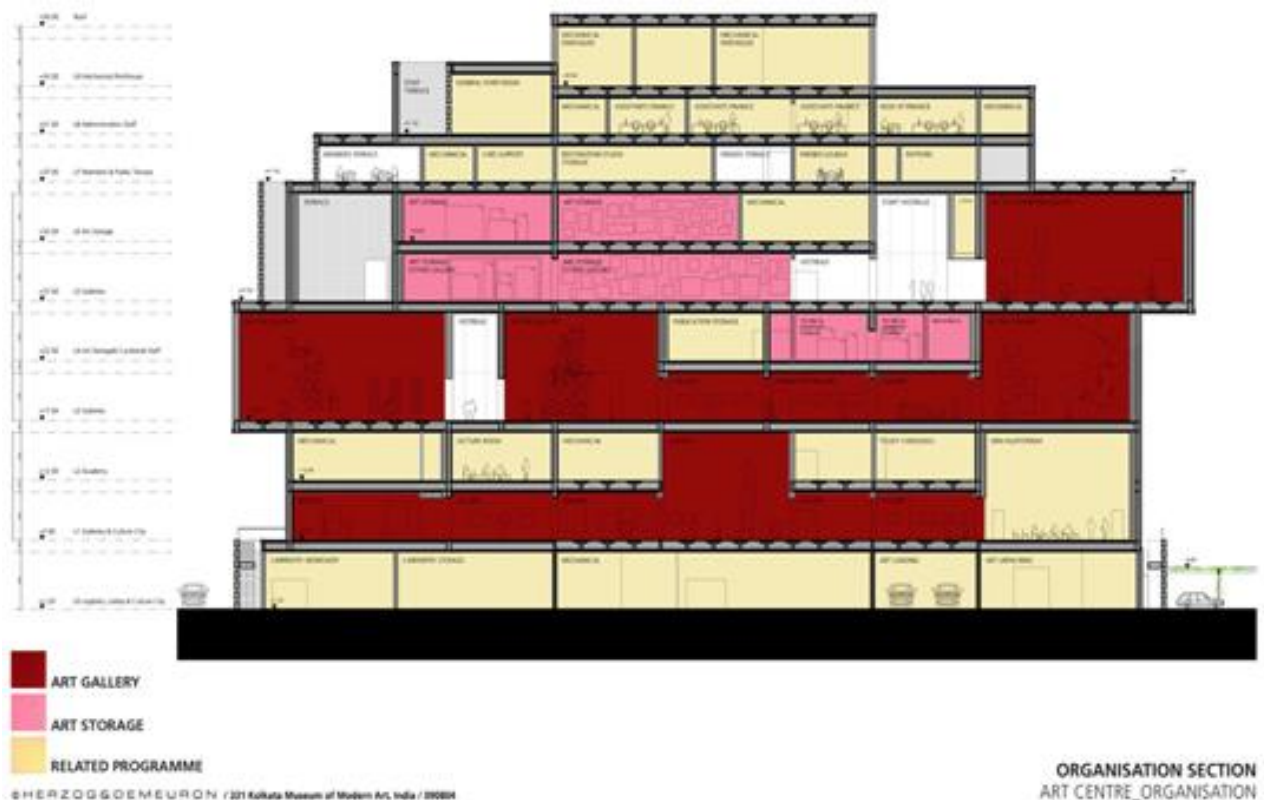

The Art Centre will have

- 44 galleries, some of which will have works of art from KMOMA's collection displayed in rotation for variety
- Regular exhibitions addressing a wide range of subjects, media and chronological periods
- Proper storage of art works
- A state-of-the-art library & an archive containing research material on Modern Art and Culture from across the globe
- Interesting programs to promote an understanding of Modern Art
- Gallery talks, symposia, workshops for artists, art lovers and students
- Guided audio tours

- Shows of classics and contemporary films, retrospectives, works of experimental filmmakers
- Special events for students and teachers
- Curatorial depts. to maintain study centers for artists, students and research scholars
- Restoration Laboratories
- A members lounge
- Office Administration



The Culture Hub will have

- An amphitheater to seat 1500
- An auditorium with a capacity of 500
- Studio facilities on the campus for visiting artists
- Artists' Residences
- Sculpture Garden
- Restaurants/Cafés
- Retail outlets/Museum Shop
- Marshalling areas
- Car Park
- Ticket booking



4.1.4 Building and Climate



Kolkata has a tropical wet and dry climate, experiencing hot and humid summers and high levels of precipitation in the monsoon season. The new Kolkata Museum of Modern Art aims to use passive methods where feasible to control the climate in and around the building, offering comfort and relief to visitors during periods of extreme weather. The building is constructed from unique cast masonry blocks which create mass within the facade. Specific volumes are shifted relative to one another to protect facades below from direct exposure to the sun, or to create shaded exterior spaces. Open and dense screens have been employed extensively to provide shade but simultaneously maintain light quality. The urban scale spaces such as residences and market areas are similarly shaded and offer natural cross ventilation through careful planning. Consideration has been given to the selection of materials for such a climate, particularly where visitors are able to interact directly with the fabric of the building.

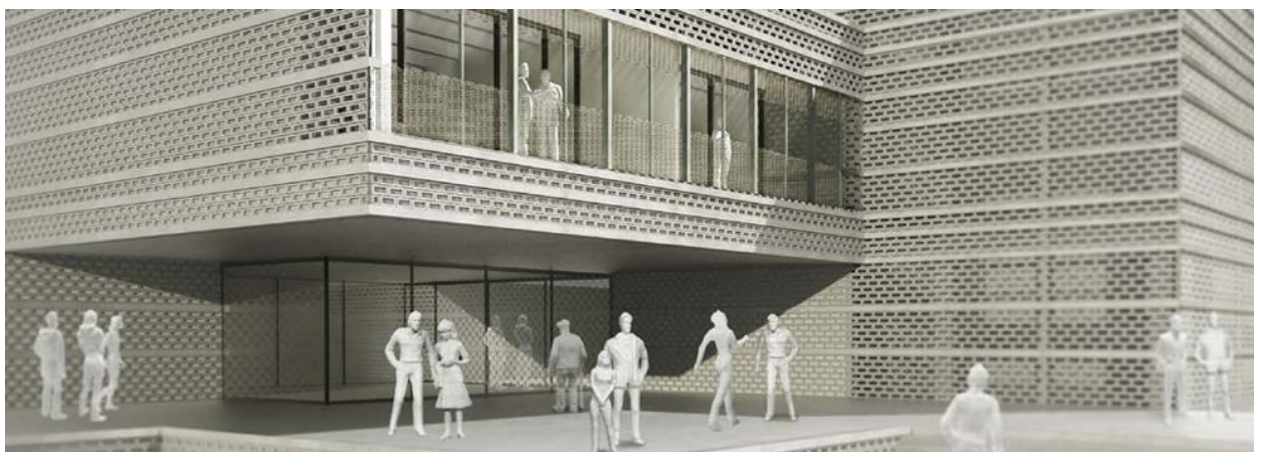

4.1.5 Landscape and Vegetation

The landscaping proposal plays an important role in bringing together the diverse building program, public space and quality of the cultural and natural landscape. The site is treated as a one, bound by a green wall and planting of perimeter trees. At pedestrian entrances, pathways

move through the lush green landscape to the building edge where the hard floor surfaces and building volumes are punctuated by densely planted light wells. Several distinct courtyards create diversity through unique planting, orienting the visitor within the site. Seasonal variation will also be evident, most visibly through a water basin in the Central Plaza which will swell during the monsoon season and retreat during the drier months.



(**Source:** Herzog & de Meuron, KMOMA)

4.1.6 Findings

The building responds to the Kolkata's tropical climate by utilizing passive design methods.

Volumes are strategically placed to control sun exposure during hot and humid summers, while a water basin in the Central Plaza swells during the Monsoon season.

Lush vegetation further enhances the environment by weaving together the diverse building program and providing a pleasant transition for pedestrians approaching the museum.

4.2 Case Study 02

Project Name: GC Prostho Museum & Research Center

Location: Japan

Architect: Kengo Kuma & Associates

Project Area: Site Area: 421.55 sqm

Built Area: 233.95 sqm

Total Floor Area: 626.5 sqm

4.2.1 Introduction

GC Prostho manufactures dental prosthetics. It required a satellite combining private and public function areas: advanced laboratory and office facilities for 40 people as well as exhibition space to commemorate the company's 50th anniversary. The architect responded with the structural experimentation that's become a hallmark of the firm and goes to great lengths to achieve effects of lightness. For GC Prostho, Kengo Kuma was wary of "thick columns," preferring to base his concept on a scale that is close to the human bodies, that possesses the delicacy and strength of arms and legs.



4.2.2 Plans

プロソミュージアム・リサーチセンター

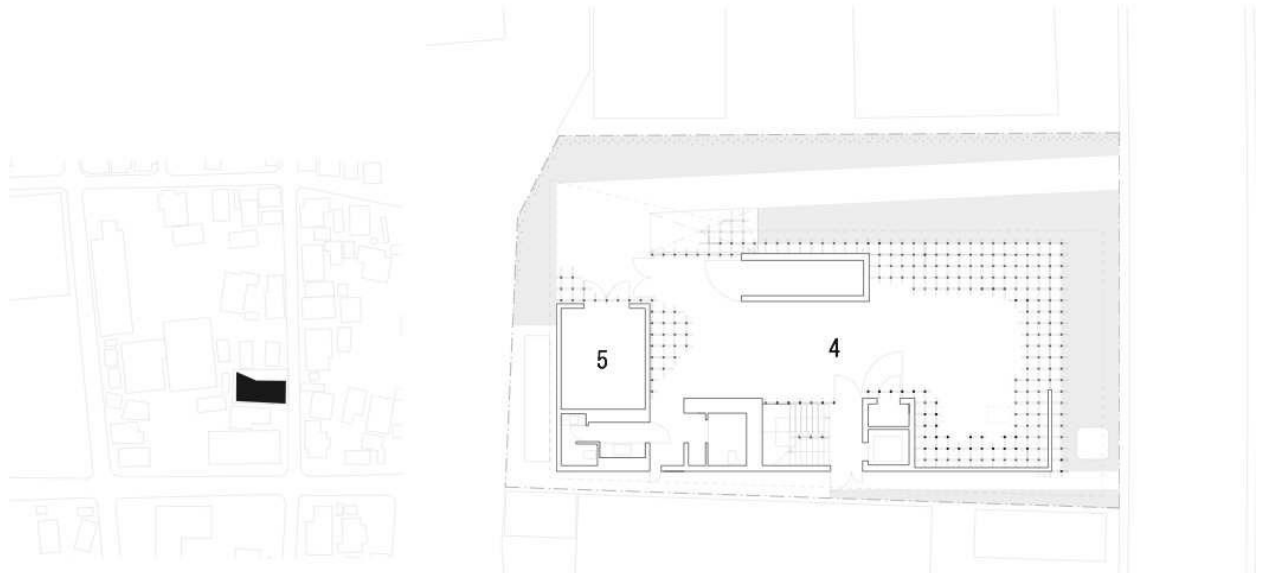

- 1 communal space
- 2 archive
- 3 dry area
- 4 gallery
- 5 electricity room
- 6 bureau
- 7 laboratory

1F 1/200

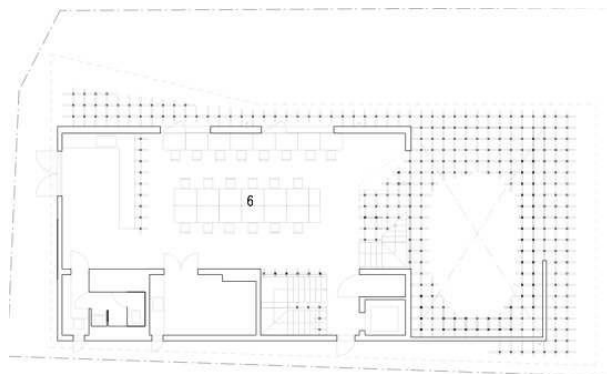

- 1 communal space
- 2 archive
- 3 dry area
- 4 gallery
- 5 electricity room
- 6 bureau
- 7 laboratory

2F 1/200

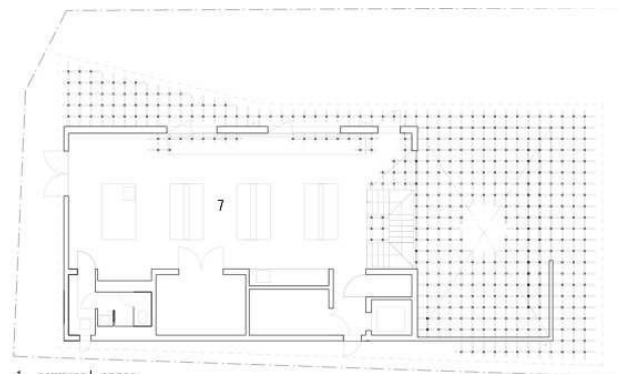

- 1 communal space
- 2 archive
- 3 dry area
- 4 gallery
- 5 electricity room
- 6 bureau
- 7 laboratory

3F 1/200

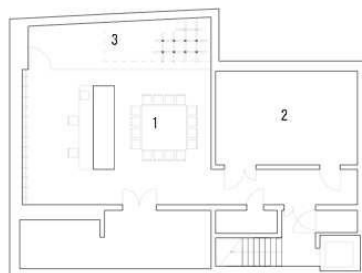

B1F 1/200

- 1 communal space
- 2 archive
- 3 dry area
- 4 gallery
- 5 electricity room
- 6 bureau
- 7 laboratory

4.2.3 Elevation and Section

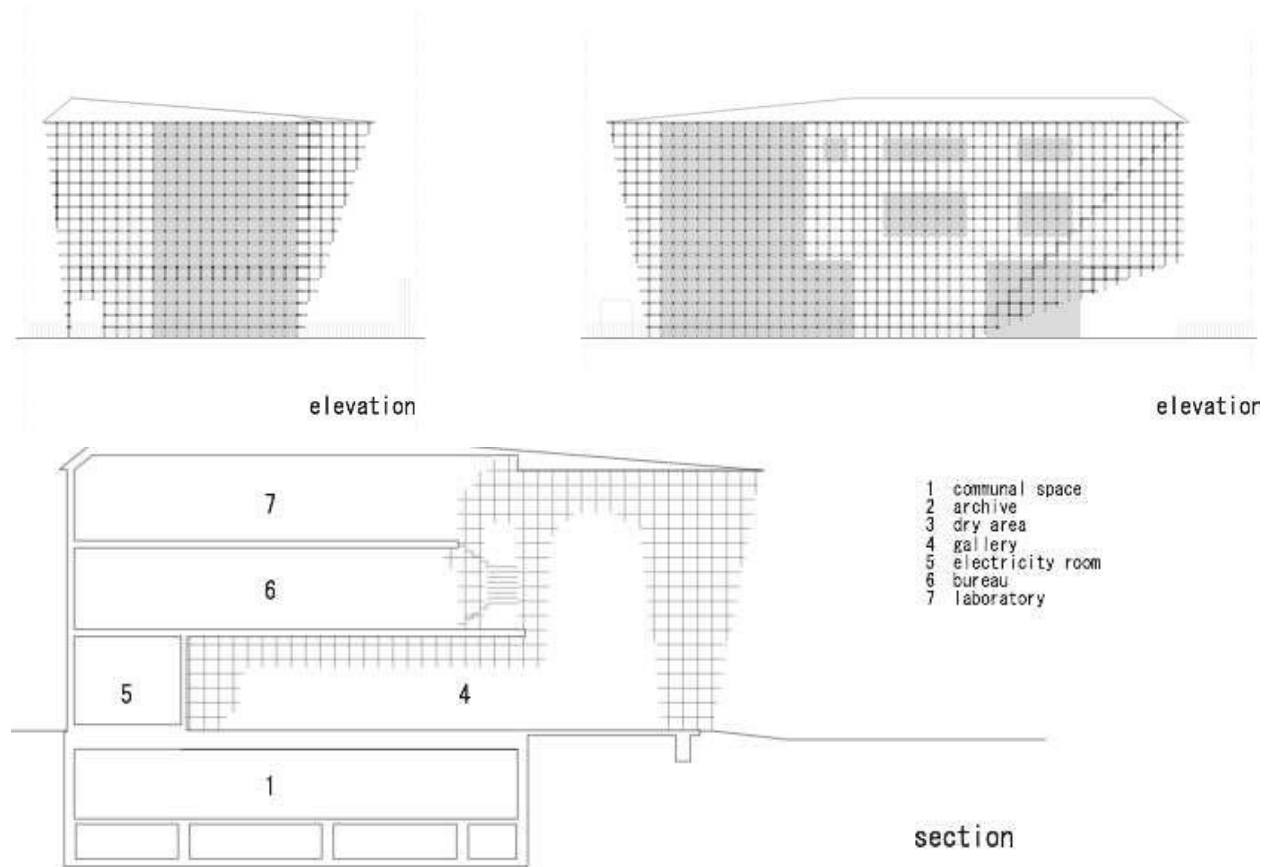

4.2.4 Structure

This is architecture that originates from the system of Cidori, an old Japanese toy. Cidori is an assembly of wood sticks with joints having unique shape, which can be extended merely by twisting the sticks, without any nails or metal fittings. The tradition of this toy has been passed on in Hida Takayama, a small town in a mountain, where many skilled craftsmen still exist.

Cidori has a wood 12 mm square as its element, which for this building was transformed into different sizes. Parts are 60mm×60mm×200cm or 60mm×60mm×400cm, and form a grid of 50cm square. This cubic grid also becomes the grid on its own for the showcase in the museum.

Jun Sato, structural engineer for the project, conducted a compressive and flexure test to check the strength of this system, and verified that even the device of a toy could be adapted to 'big' buildings. This architecture shows the possibility of creating a universe by combining small units like toys with your own hands. The project intends to create the hope that the era of machine-made architectures would be over, and human beings would build them again by themselves.

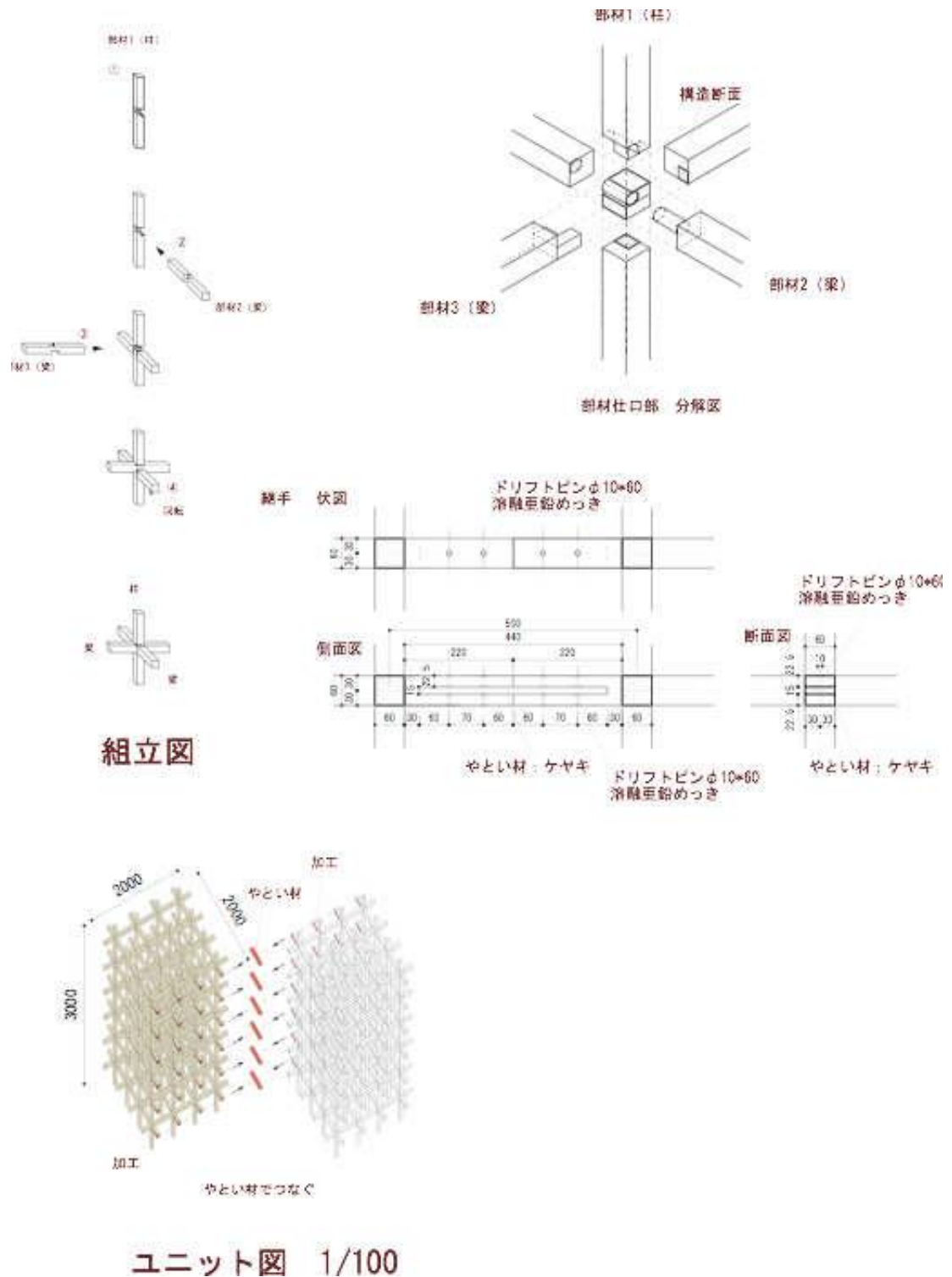

The ground level of this three-story hybrid is devoted to a gallery swathed in cypress latticework. Securely attached by steel plates to the walls-which are covered with a cement-board usually intended to be concealed but here polished to a sheen-the latticework actually performs structural duty in addition to being a marvelously deep modulator of the abundant sunlight that spills from the south-facing window wall. Sharply defined shadows, mesmerizing in their complexity, shift across the concrete floor. As one gazes upward, into the lattice vault, the eyes easily get lost among the plethora of patterns that present themselves from different angles.





(Source: Kengo Kuma & Associates, ArchDaily)

4.2.5 Findings

The architect treats a walk inside the building with a walk in a deciduous tree forest, where one can enjoy the sunlight through the branches. His repulsion towards the use of concrete and metal led him to redefine the use of wood through a traditional Japanese game.

Building with wood from the surrounding area, with the Cidori system, also suggests an alternative solution to modern architecture: the building as a result of human labor instead of mechanical perfection. A look to the future with the feet firmly planted in a centuries old tradition.

4.3 Case Study 03

Project Name: Museum of Handcraft Paper

Location: Yunnan, Tengchong, Xinzhuang Village, China

Architect: TAO (Trace Architecture Office) – HUA Li

Project Area: Floor Area: 361 sqm.

Lot size: 300 sqm



4.3.1 Site

The museum of handcraft paper is located in a field next to Xinzhuang village under Gaoligong Mountain of Yunnan, a world ecological preserve area in southwest of China. The village has a long tradition on handcraft paper making. The site is next to the main road entering the village. The museum functions like a preview window of the village, in the sense that the whole village will function as a big museum because each home in village will open to the visitors showing papermaking process. The museum is thus conceived as a micro-village, a cluster of several small buildings. The building scale is in concord with adjacent village and landscape.

4.3.2 Program & Concept

The design is aimed at making a building rooted in local environment. This leads to the concept that the construction is to maximize the usage of local materials, construction method and

traditional craftsmanship and to be built completely by local builders. Yet it also employs the modern materials and technique available in local context. Thus the construction of museum will be both a preservation and transformation of local building tradition. It is an architectural attempt of combining modern quality with regional character by using local resources and suitable techniques in the rural context of contemporary China.

The spatial concept is to create a visiting experience alternating between exhibition inside and landscape outside when visitor walks through the galleries on ground level, so as to provoke an

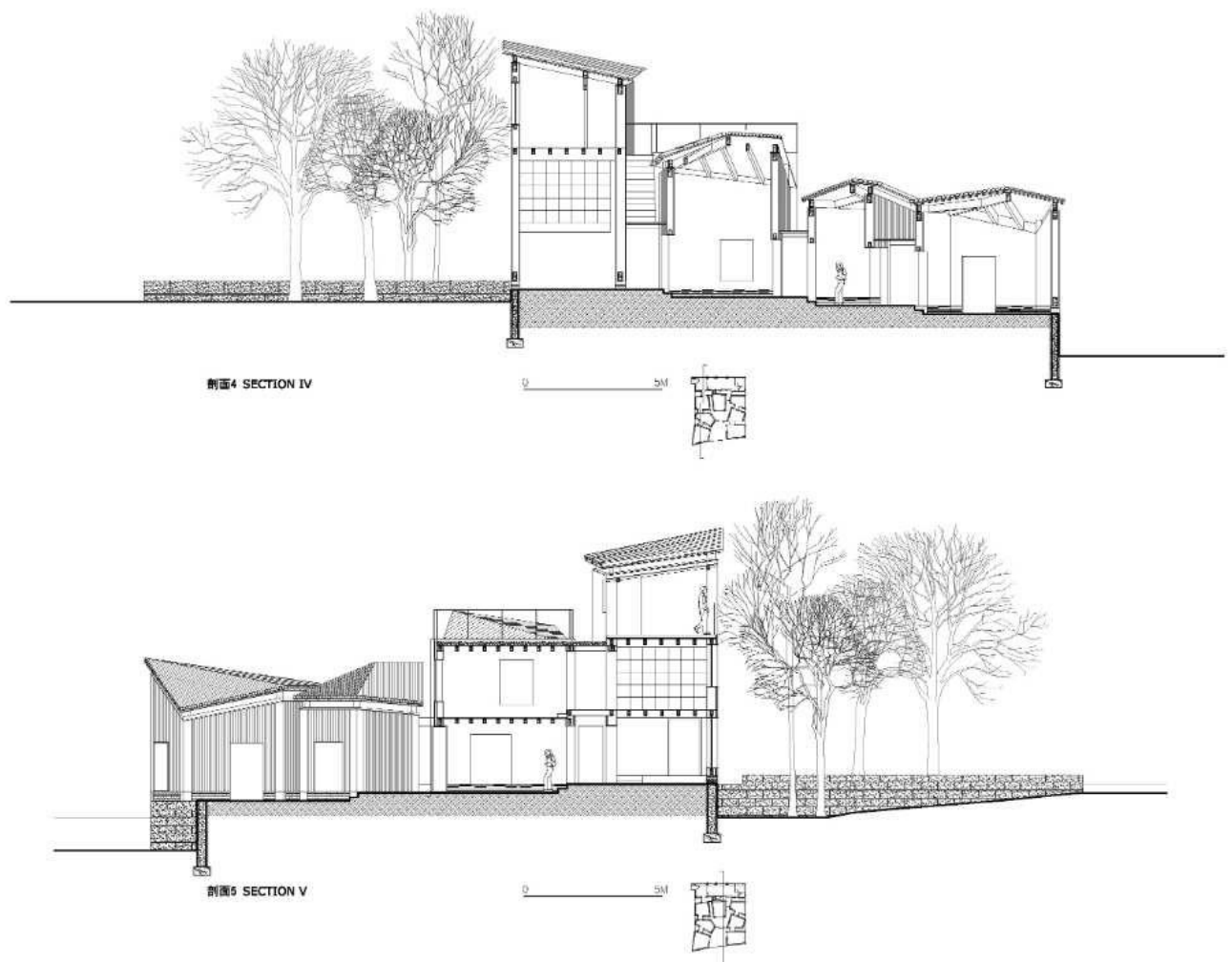

awareness of the inseparable relationship between paper making and environment. On second level, there is an open work space and meeting room. Through an outdoor stair, one can walk up to roof terrace with a view to the bamboo roofscape of galleries below, and a glass roofed veranda space facing east where one can have a panoramic view to Gaoligong mountain.

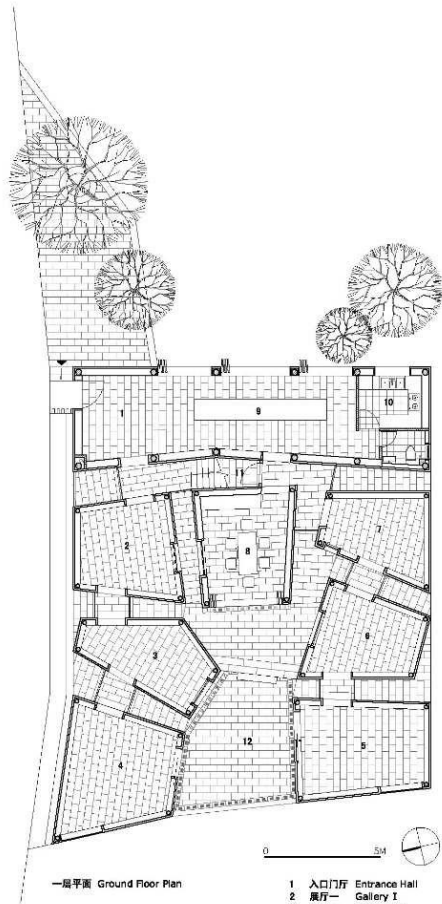

一层平面 Ground Floor Plan

- 1 入口门厅 Entrance Hall
- 2 展厅一 Gallery I
- 3 展厅二 Gallery II
- 4 展厅三 Gallery III
- 5 展厅四 Gallery IV
- 6 展厅五 Gallery V
- 7 展厅六 Gallery VI
- 8 茶室 Tearoom
- 9 书店 Bookshop
- 10 厨房 Kitchen
- 11 储藏室 Storage
- 12 庭院 Courtyard

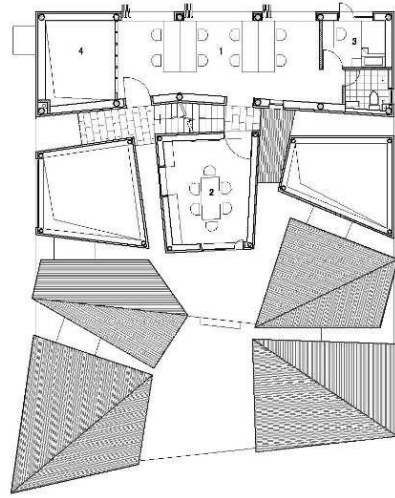

二层平面 Second Floor Plan

- 1 工作区 Work Area
- 2 会议/接待室 Meeting/Reception
- 3 办公室 Office
- 4 门厅上空 Void

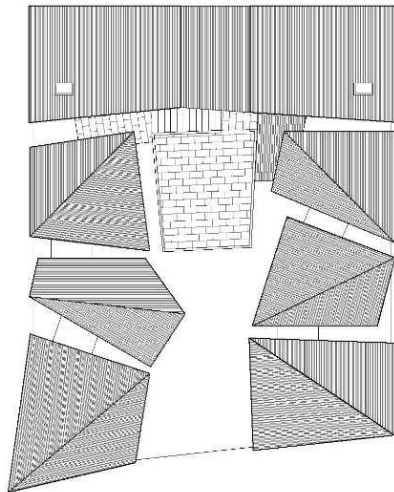

屋顶平面 Roof Plan

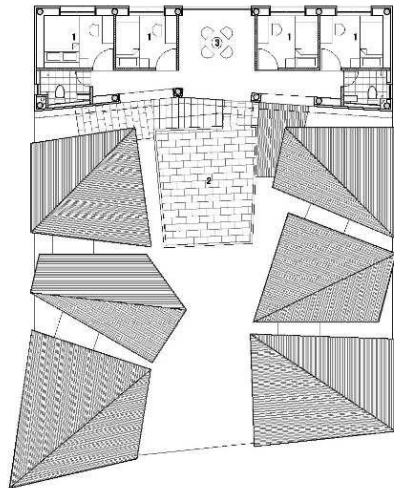

三层平面 Third Floor Plan

- 1 客房 Guest room
- 2 屋顶平台 Roof Terrace
- 3 观景平台 Lounge

4.3.3 Structure

The building is designed with traditional Chinese wood structural system featuring nail-less tenon (SunMao) connection, which can be skillfully built by local builders. Local materials such as fir wood, bamboo, volcano stone and handcraft paper are used for exterior finish, roof, floor and interior finish respectively. With time passed, these materials will worn and fade into a more harmonious color with the landscape. These living materials hint a sense of time on building.

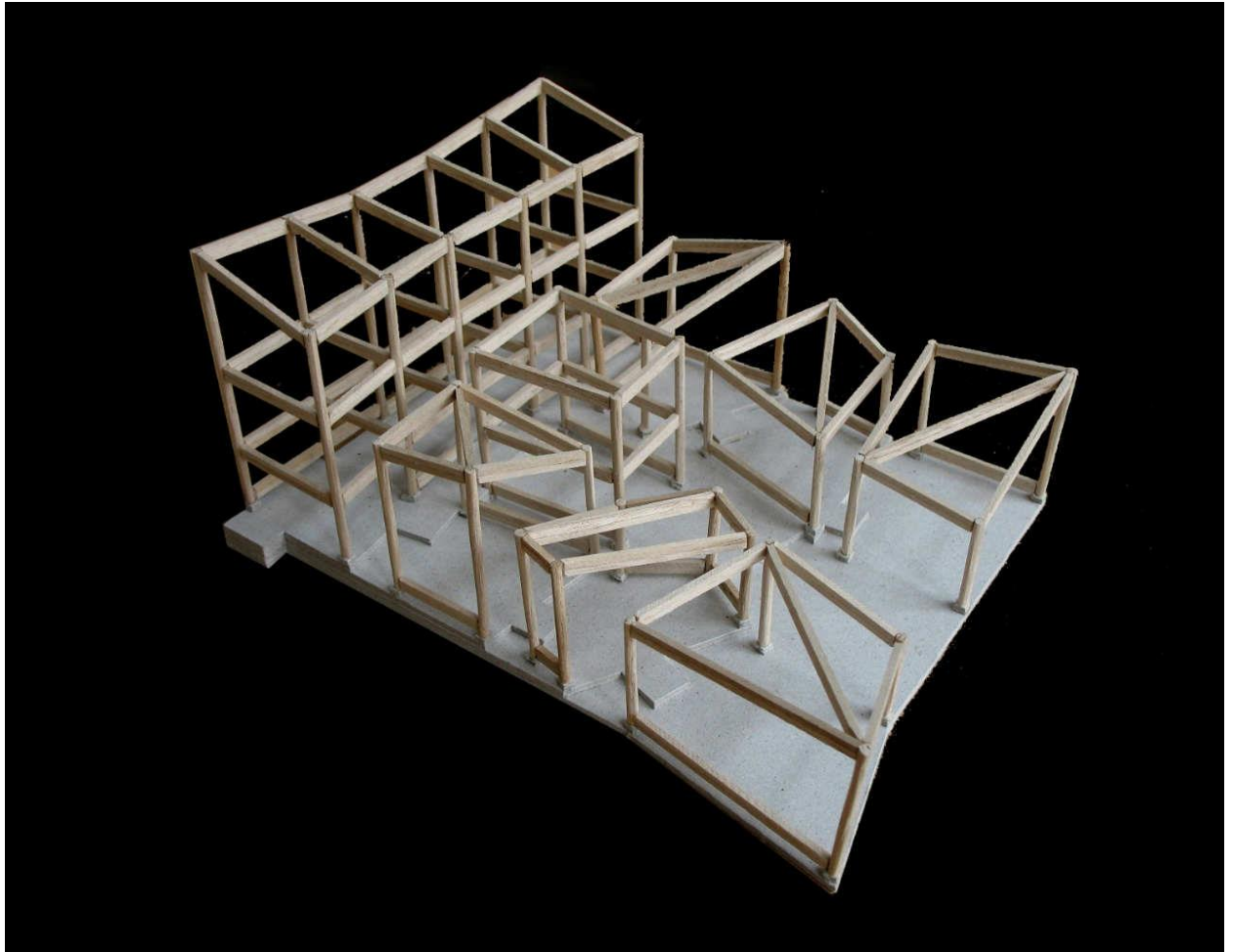



(**Source:** TAO, Aga Khan Award for Architecture Shortlist 2013)

On facade, the exterior wall stops at the bottom of beam level and exposes beam and part of columns at the corners. Also with exposed roof structure at interior space and the stone column base on facade, these details reveal that the building is supported by the column and beam system instead of wall. The handcraft paper on interior finish is applied on a wood frame with 45cm by 45cm square module (limited by the paper size but guarantees the smoothness of wall). The exhibition niche layout based on this module is integrated into the wall. The white paper wall in galleries creates a soft and warm atmosphere and keeps the space abstract.

4.3.4 Findings

As if to reconstruct a district in the village it represents, the building has a beam and column structure with cross connections and fir walls, built using local construction techniques, divided into a series of towers of different heights and shapes with a central courtyard and a path uniting them.

The bamboo roofs, use of local volcanic stone in the wall foundations to promote ventilation and the composition of the volumes with their covered and open corridors in which the breeze naturally cools the building are citations of methods and techniques which were used to build the village over the years and are still in use today; the penetration of light and the view over the landscape created by the relationship between solid and open volumes helps improve the quality of the architecture.

All the inside walls are covered completely with paper made locally by hand: 45 x 45 cm sheets of paper were assembled on wooden frames to create neutral spaces for the museum exhibitions.

The numerous large openings on the inside walls also recreate the image of the village of small houses with windows framing beautiful landscapes, while on the outside walls slits at the base of the roof to let light in are covered with handmade paper applied to the glass to preserve the light-filled quiet of the rooms.

Chapter 5: Program Development

5.1 Museum

5.2 Research Center

5.3 Recreational / Common Area

5.4 Grand Total

5.1 MUSEUM

SPACE	SPACE REQUIRED PER PERSON (SQ-FT)	NO. OF USERS	SPACE REQUIRED PER ROOM (SQ-FT)	NO. OF ROOMS	AREA REQUIRED (SQ-FT)
LOBBY (Reception + Information Desk)	6.5	200			1300
PERMANENT EXHIBITION SPACE					10000
TEMPORARY EXHIBITION SPACE					7000
EXHIBIT PRESERVATION / PREPARATION AREA	184	10		1	1840
STORAGE					500
RETAIL AREA					500
WASHROOMS			160	2	320
SUBTOTAL					21460
Circulation (30%)					6438
TOTAL					27898

Administration

SPACE	SPACE REQUIRED PER PERSON (SQ-FT)	NO. OF USERS	SPACE REQUIRED PER ROOM (SQ-FT)	NO. OF ROOMS	AREA REQUIRED (SQ-FT)
DIRECTOR			300	2	600
CURATOR			300	1	300
STAFF	80	6			480
CONFERENCE ROOM	20	15		1	300
AREA FOR REPROGRAPHY STORAGE					100
WASHROOMS			160	2	320
SUBTOTAL					2300
Circulation (30%)					690
TOTAL					2990

5.2 RESEARCH CENTER

Workshops

SPACE	SPACE REQUIRED PER PERSON / EQUIPMENT (SQ-FT)	NO. OF USERS	SPACE REQUIRED PER ROOM (SQ-FT)	NO. OF ROOMS	AREA REQUIRED (SQ-FT)
THREAD PREPARATION	184 + 100 + 15	10	300	3	900
JACQUARD PREPARATION	10	15	150	1	150
WEAVING / LOOM PRODUCTION	80	8	640	2	1280
NAKSHI KANTHA / KARCHUPI / OTHERS	20	40	800	2	1600
STORAGE					1500
WASHROOMS			200	2	400
SUBTOTAL					5830
Circulation (30%)					1749
TOTAL					7579

Research Lab

SPACE	SPACE REQUIRED PER PERSON / EQUIPMENT (SQ-FT)	NO. OF USERS	SPACE REQUIRED PER ROOM (SQ-FT)	NO. OF ROOMS	AREA REQUIRED (SQ-FT)
COMPUTER LAB	10	30			300
RESEARCH LAB	50	15		1	750
MATERIAL TREATMENT			2000	3	6000
SUBTOTAL					7350
Circulation (30%)					2205
TOTAL					9555

Administration

SPACE	SPACE REQUIRED PER PERSON (SQ-FT)	NO. OF USERS	SPACE REQUIRED PER ROOM (SQ-FT)	NO. OF ROOMS	AREA REQUIRED (SQ-FT)
DIRECTOR			300	2	600
STAFF	80	6			480
CONFERENCE ROOM	20	15		1	300
AREA FOR REPROGRAPHY					100
WASHROOMS			160	2	320
SUBTOTAL					1800
Circulation (30%)					540
TOTAL					2340

Library

SPACE	NO. OF USERS		SPACE REQUIRED PER ROOM (SQ-FT)		NO. OF ROOMS		AREA REQUIRED (SQ-FT)
LOBBY							200
CHECK AREA AND LOCKER							200
READING AREA	150				1		1500
BOOK STACK	20,000 Books		0.1 / Book				2000
LIBRARIAN'S ROOM	2		100		2		200
AUDIO - VISUAL							800
COPY SECTION					1		200
MATERIAL SECTION							800
WASHROOMS	USERS	OFFICE	160	80	2	1	400
SUBTOTAL							6300
Circulation (30%)							1890
TOTAL							8190

5.3 Recreational / Common Area

SPACE	SPACE REQUIRED PER PERSON (SQ-FT)	NO. OF USERS	SPACE REQUIRED PER ROOM (SQ-FT)		NO. OF ROOMS		AREA REQUIRED (SQ-FT)
MULTIPURPOSE HALL	10	200			1		2000
LOUNGE							1000
RESTAURANT	18	150					2700
CAFETERIA	15	100			1		1500
KITCHEN							2100
WASHROOMS			160	80	2	2	480
SUBTOTAL							9780
Circulation (30%)							2934
TOTAL							12714

5.4 Grand Total

SPACE	AREA REQUIRED (SQ-FT)
MUSEUM	27898
MUSEUM ADMINISTRATION	2990
RESEARCH CENTER - WORKSHOPS	7579
RESEARCH LAB	9555
RESEARCH CENTER ADMINISTRATION	2340
LIBRARY	8190
RECREATIONAL / COMMON AREA	12714
Grand total	71266

Chapter 6: Conceptual Stage and Design Development

6.1 Introduction

6.2 Concept Development

6.3 Form Development & Programmatic Layout

6.4 Final Design Drawings

6.1 Introduction

Upon carrying out a relatively thorough study, one of the main findings that was brought into light was how the weavers and artisans associated with the craft for over generations wanted the following to attain proper exposure and preservation of the arts ;



This particular finding re-affirmed the need for a proper museum that would contain and further enhance our rich heritage of traditional textiles. It was also necessary to bring forth the traditional elements of this sector in a more contemporary manner so that it could gather the attention of a wider audience.

6.2 Concept Development

The initial idea of my project was using the site location to connect the significant loom production sites present over the country with the heart of the country – the city center. Purbachal provided a suitable location because it was adjacent to the Dhaka city Bypass, and provided a fresh platform for attracting a more varied group of city dwellers.

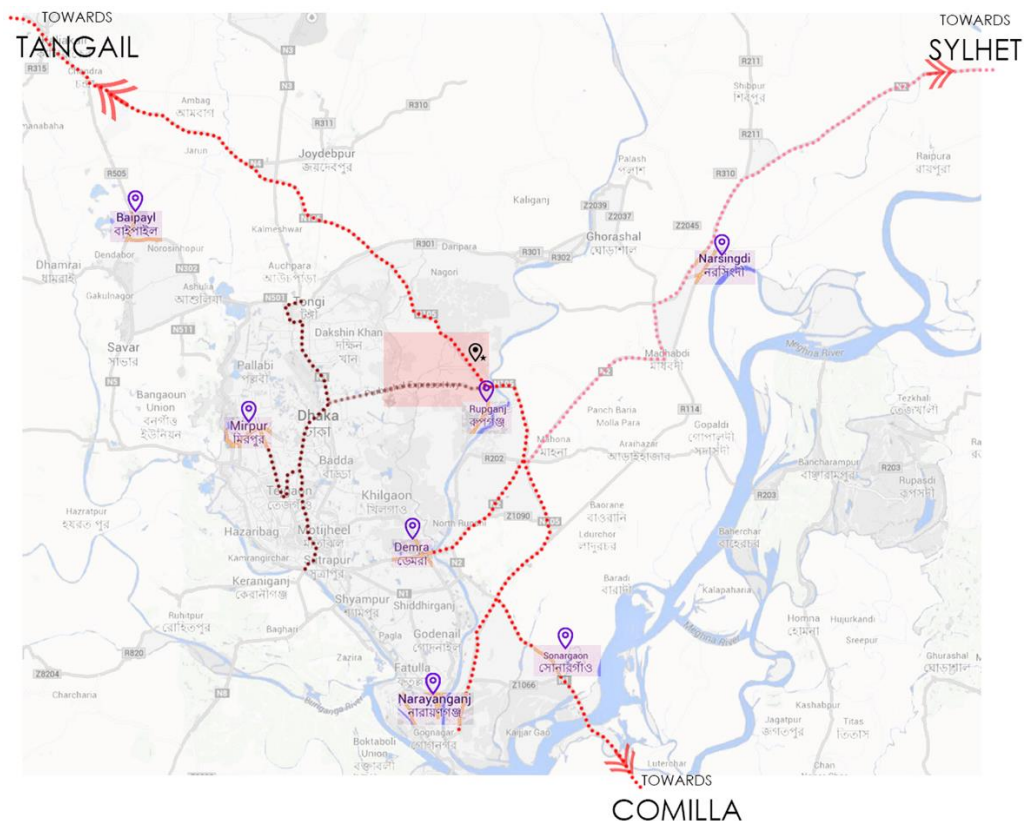

The concept of the design is mainly based on a common traditional element of handloom. The jacquard machine incorporated with a pit loom is used for mass production of traditional textiles, but is gradually being taken over by the emergence of power looms.

The Jacquard is a dominant feature in handloom production. It is produced by calculated formation of design patterns in a grid. The grid denotes the thread directions of the fabric. Each pattern produced results in scores of punched cards for one single garment.

The grid used in producing a jacquard is the main constituent of deriving my design, as the same, if not in some cases – a similar grid is the basic building unit of a traditional textile.

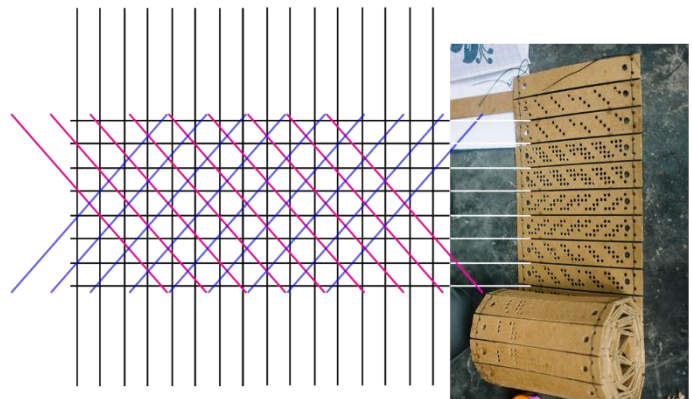
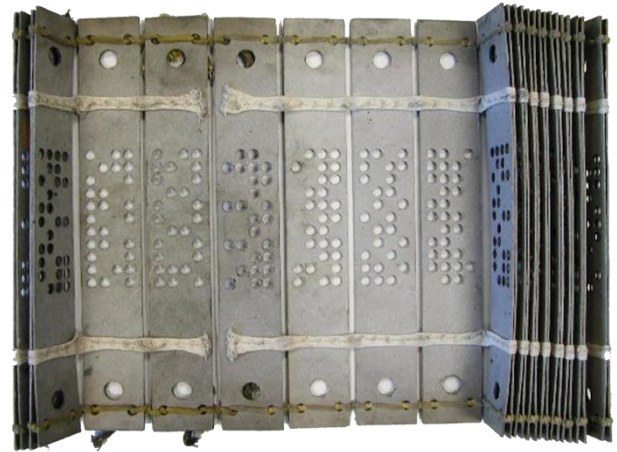

6.3 Form Development & Programmatic Layout

To derive a form using the conceptual ideology, the first thing that was done was to understand the site and its surrounding nature and amenities. Thereafter, the site was hypothetically split into segments in accordance to the grid that is used for jacquard and handloom production.

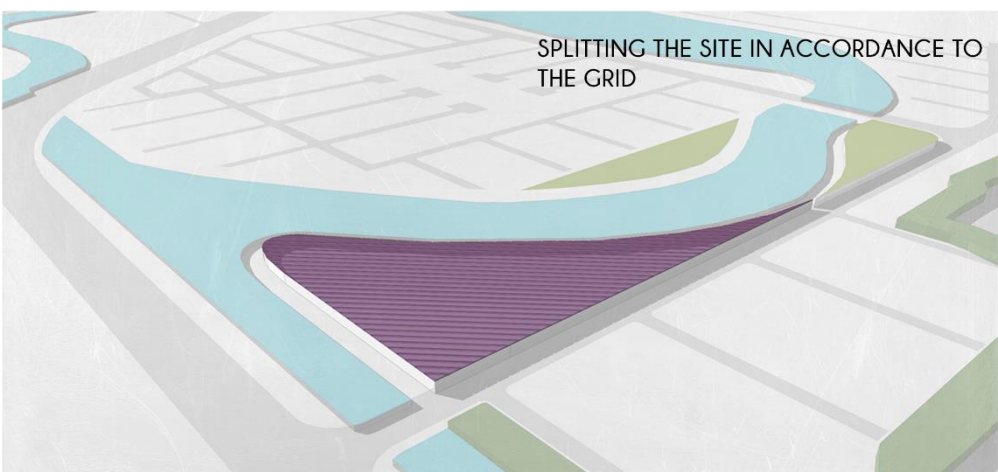
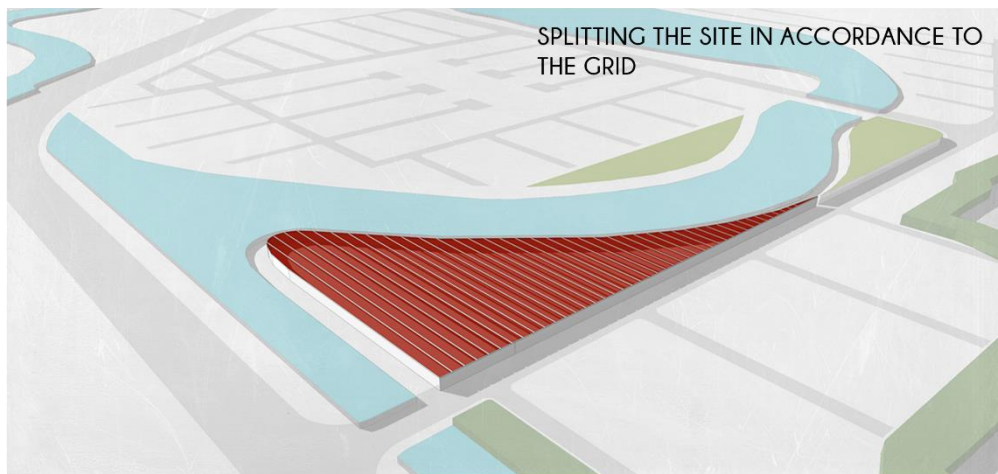

To keep the direction of the segments from becoming too imposing or out of context, the grid was aligned according to the direction of the curve present in the site. The segments were then overlapped on each other to help derive and create functional spaces.

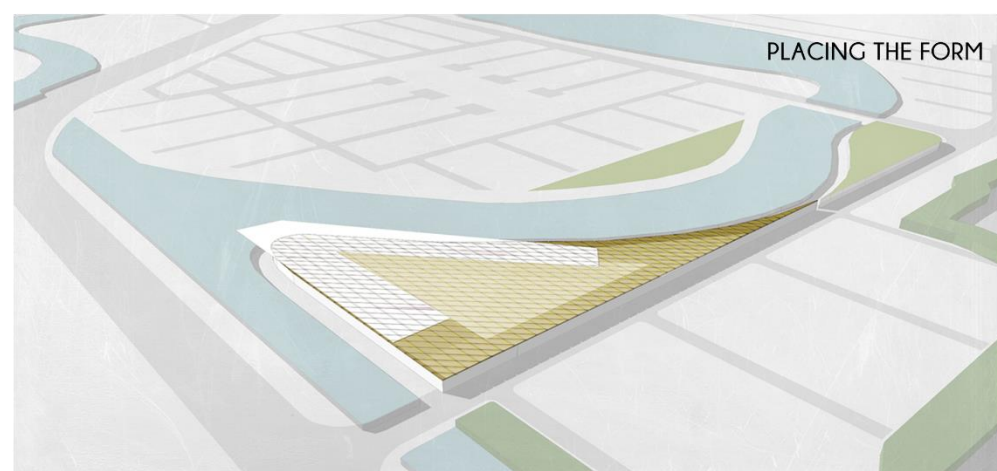
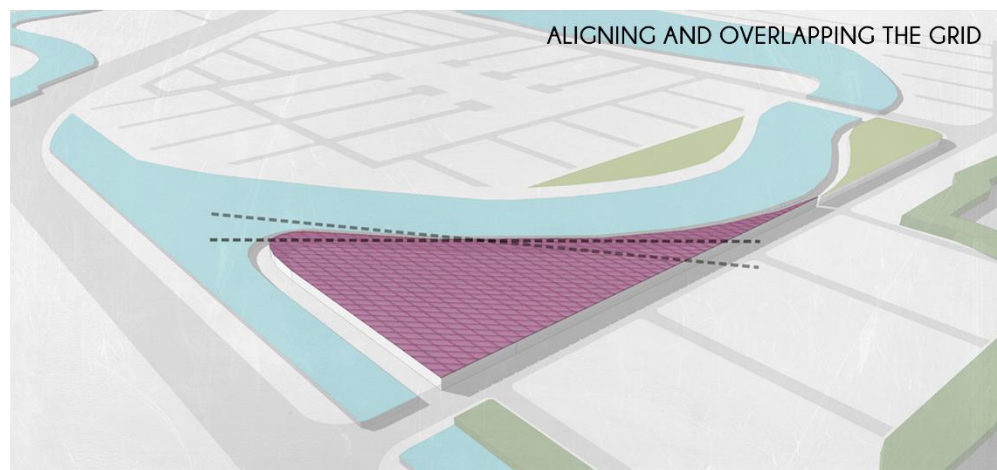
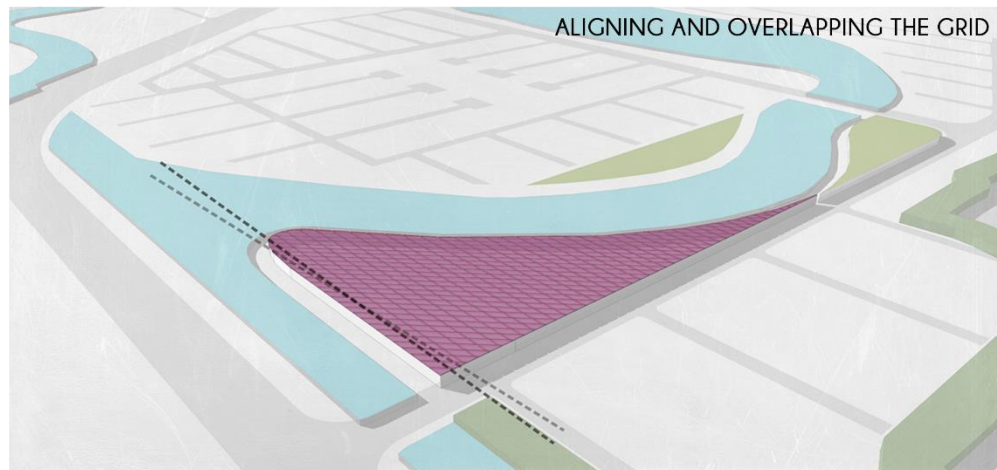

The direction and articulation of the form was kept in context of its surrounding. The form was oriented towards the west where it opened towards the water body and an urban green body. This also allowed for minimal surfaces to be exposed to the western sun and provided a shaded space towards the east and center of the site that could be efficiently utilized for public promenades. Moreover the grid was overlapped both vertically and horizontally allowing the scope for merging the form with the landscape.

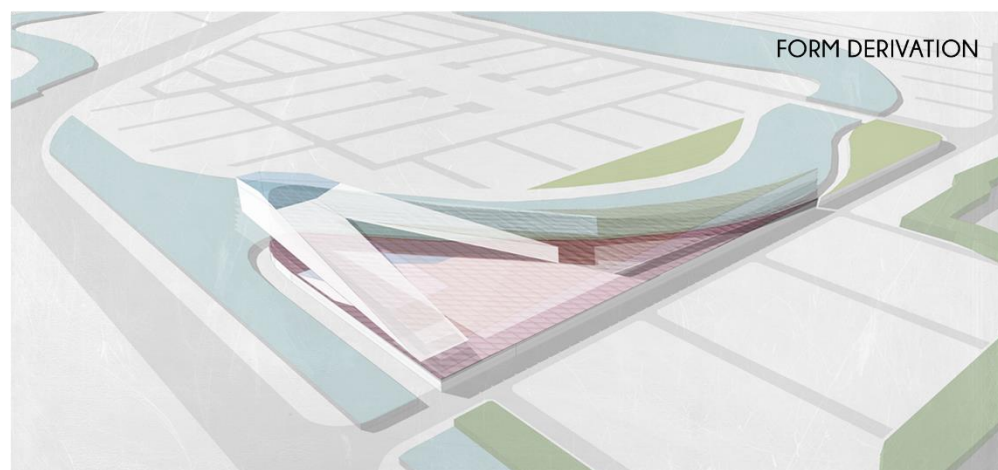
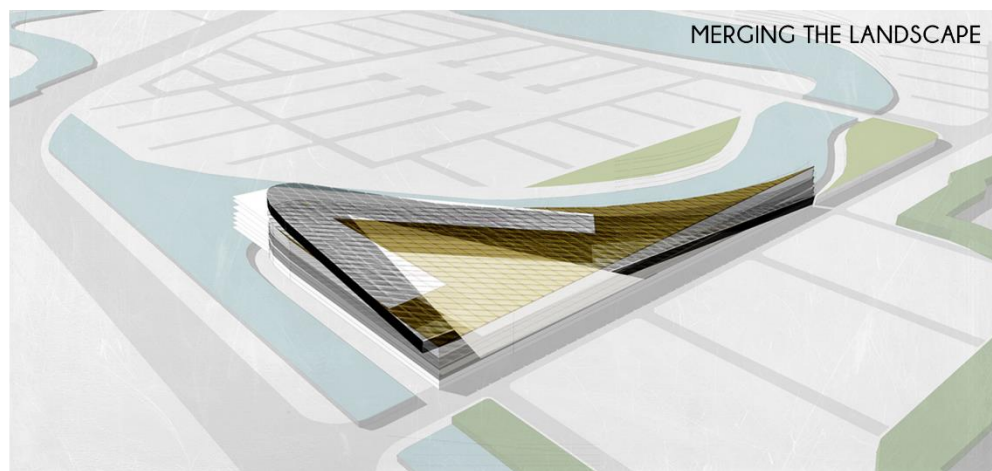
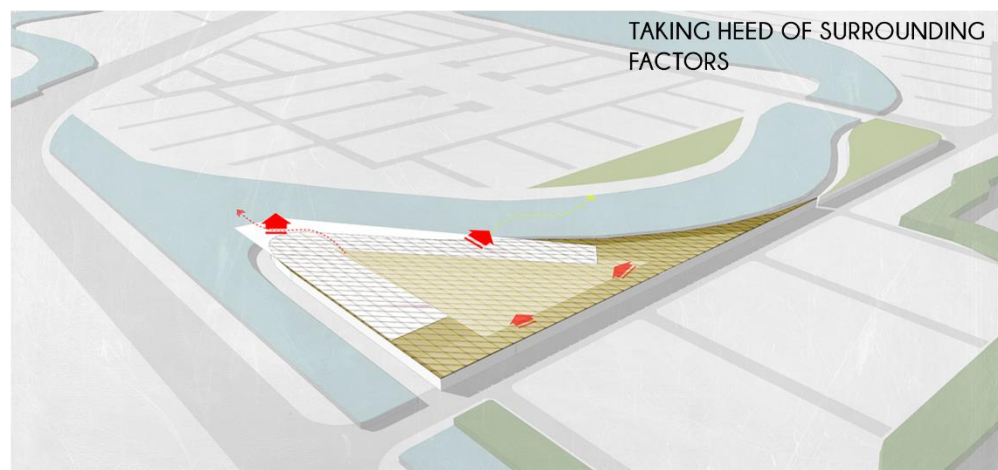

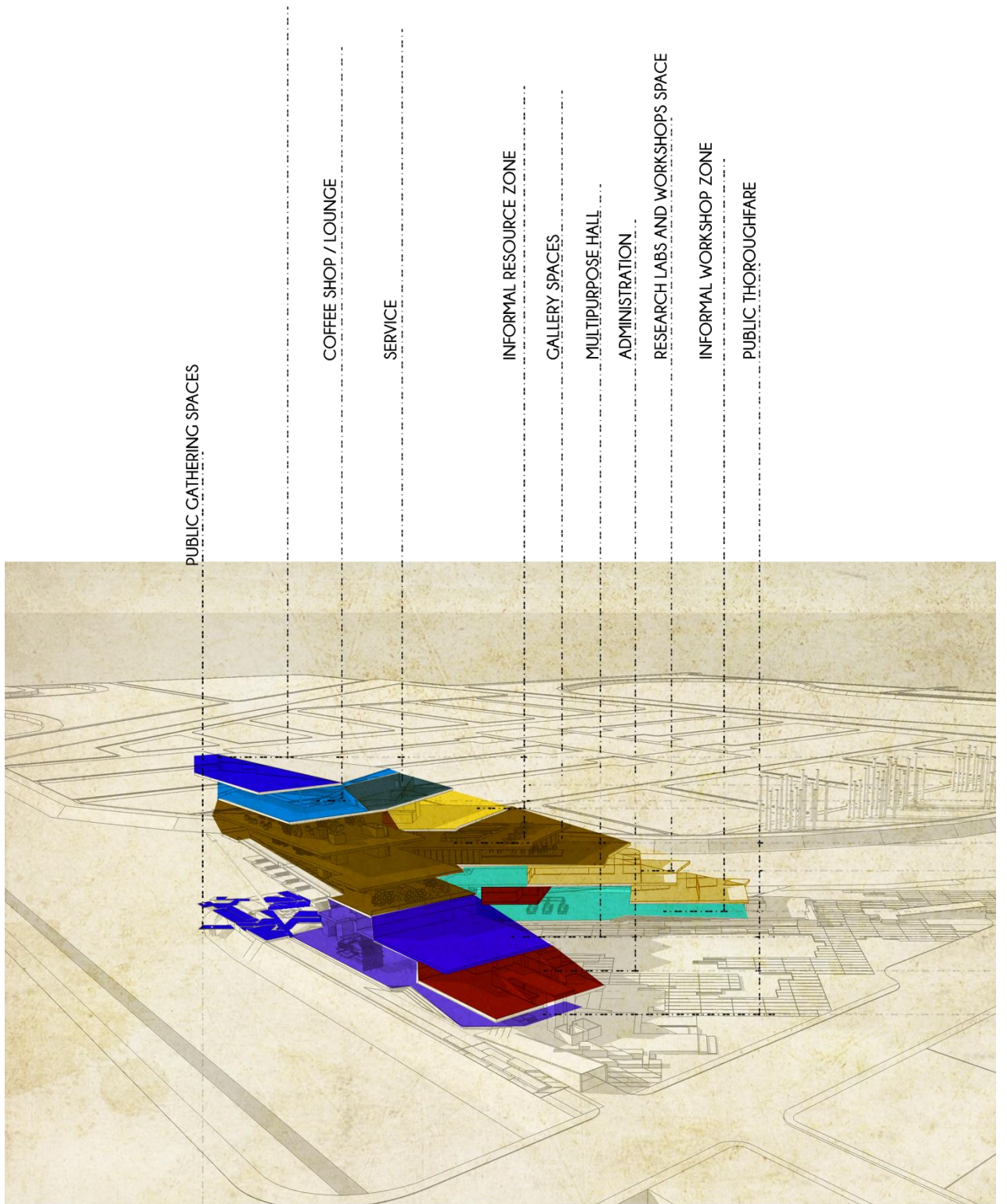

6.4 Final Design Drawings

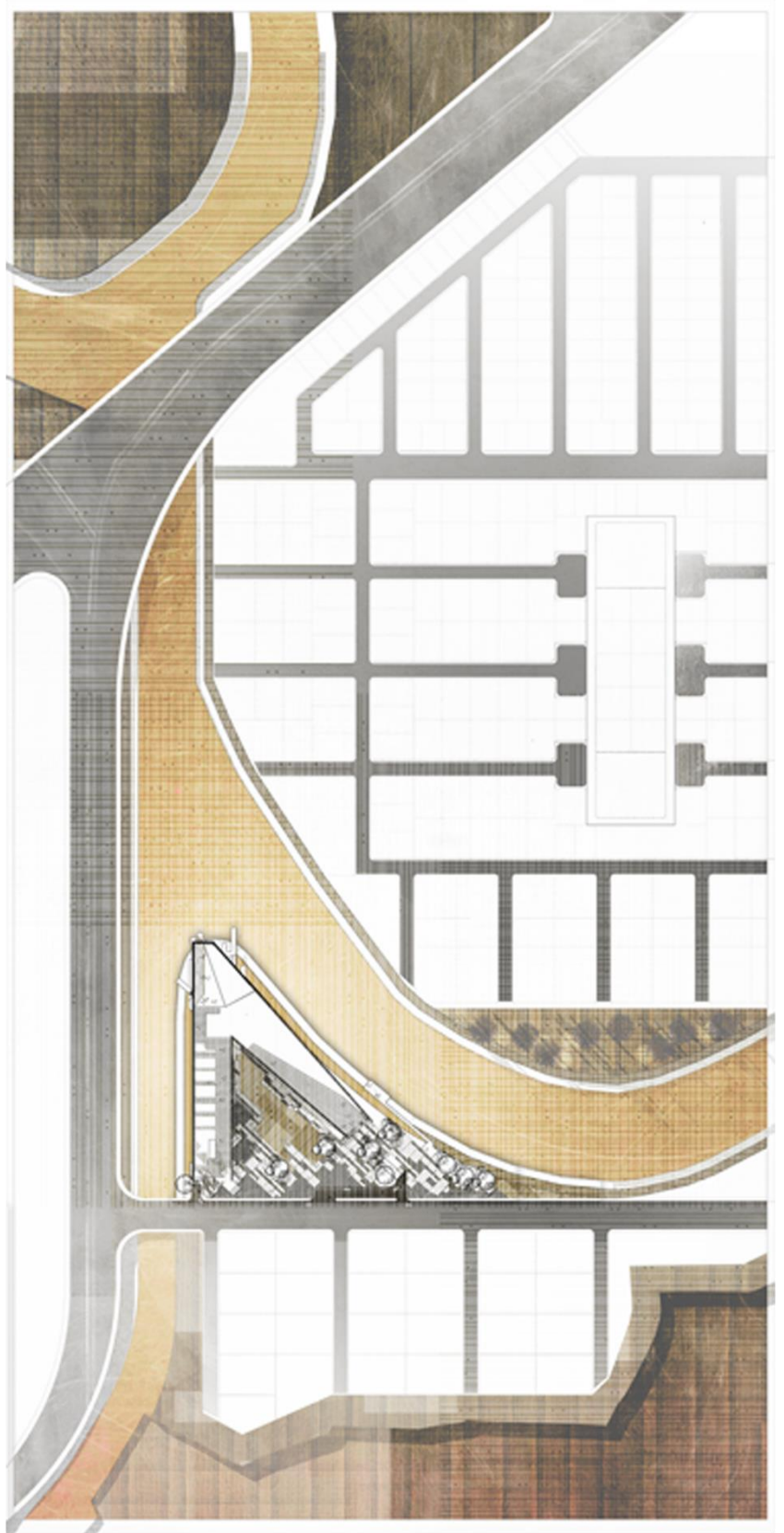

Site Plan

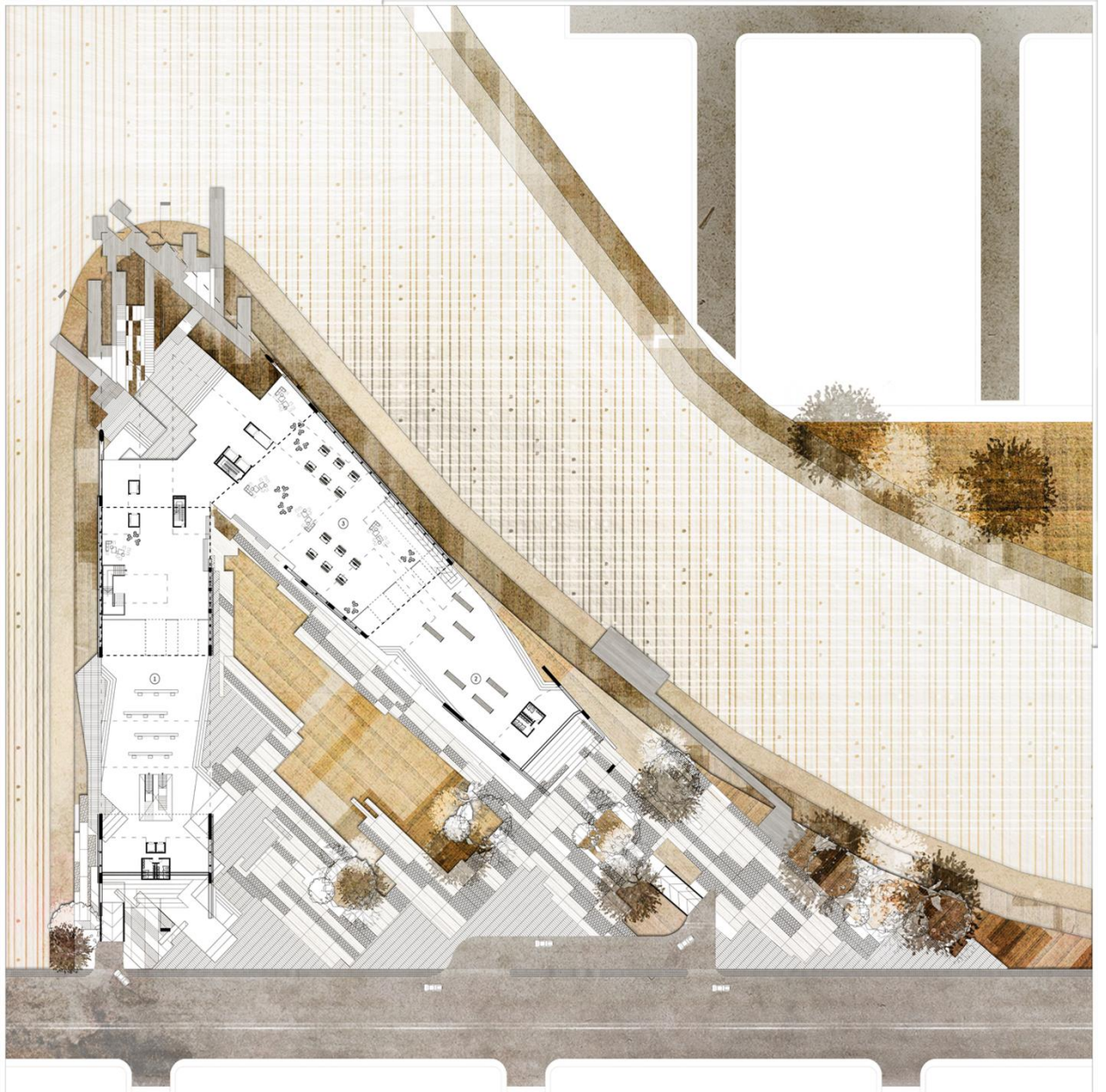

Ground Floor Plan

PLAN AT 24'-6"
SCALE: 1/16" = 1'-0"

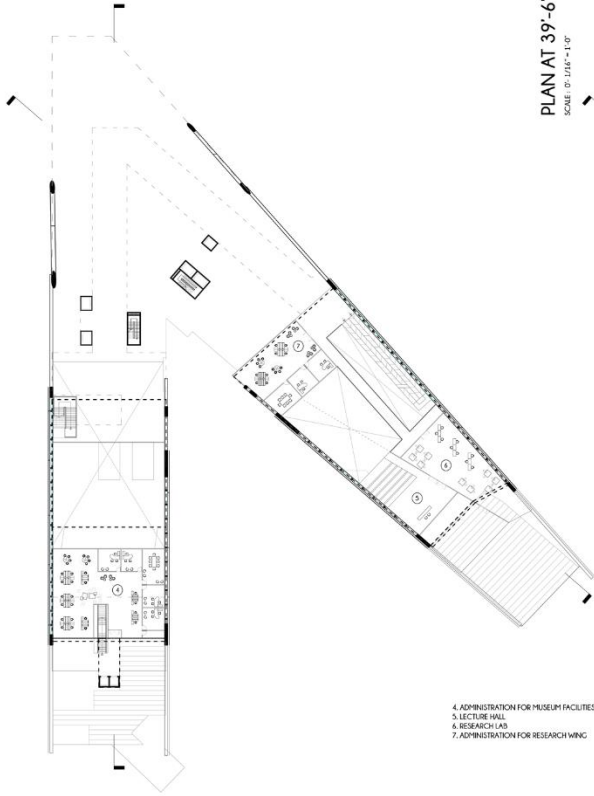

- 4. ADMINISTRATION FOR MUSEUM FACILITIES
- 5. LECTURE HALL
- 6. RESEARCH LAB
- 7. ADMINISTRATION FOR RESEARCH WING

PLAN AT 39'-6"
SCALE: 1/16" = 1'-0"

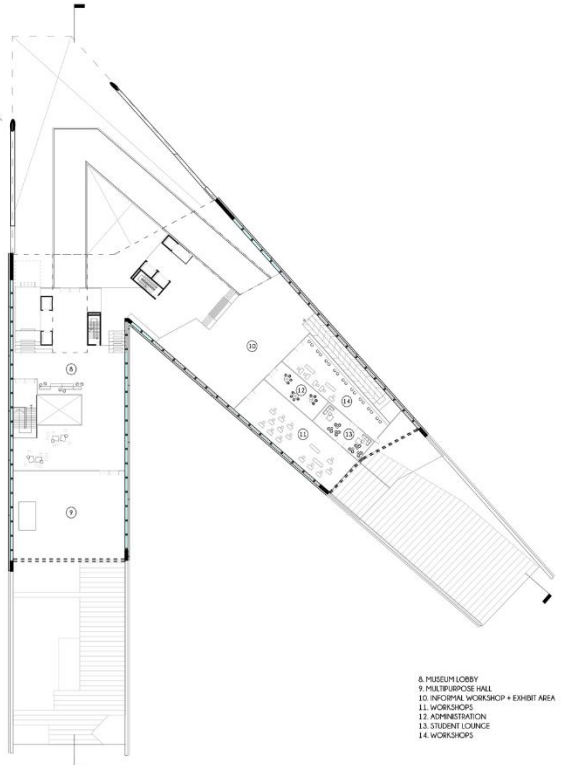

- 8. MUSEUM LOBBY
- 9. MULTIPURPOSE HALL
- 10. INFORMAL WORKSHOP + EXHIBIT AREA
- 11. WORKSHOPS
- 12. ADMINISTRATION
- 13. STUDENT LOUNGE
- 14. WORKSHOPS

PLAN AT 54'-6"
SCALE: 1/16" = 1'-0"

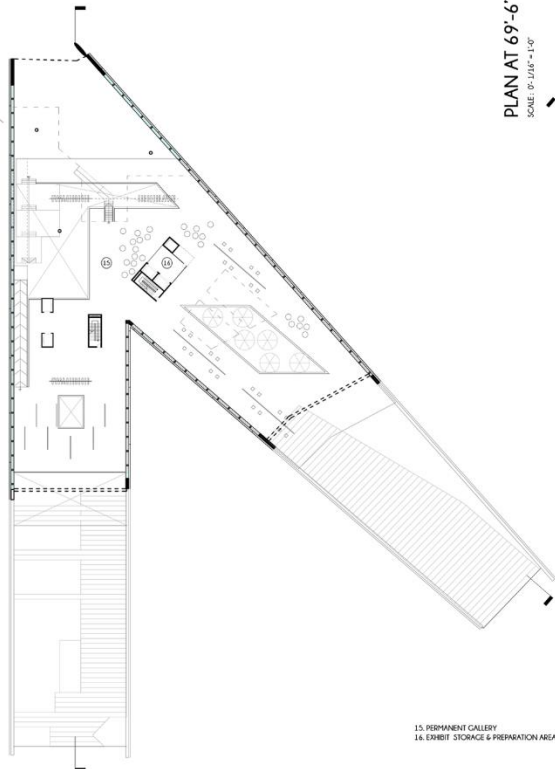

- 15. PERMANENT GALLERY
- 16. EXHIBIT STORAGE & PREPARATION AREA

PLAN AT 69'-6"
SCALE: 1/16" = 1'-0"

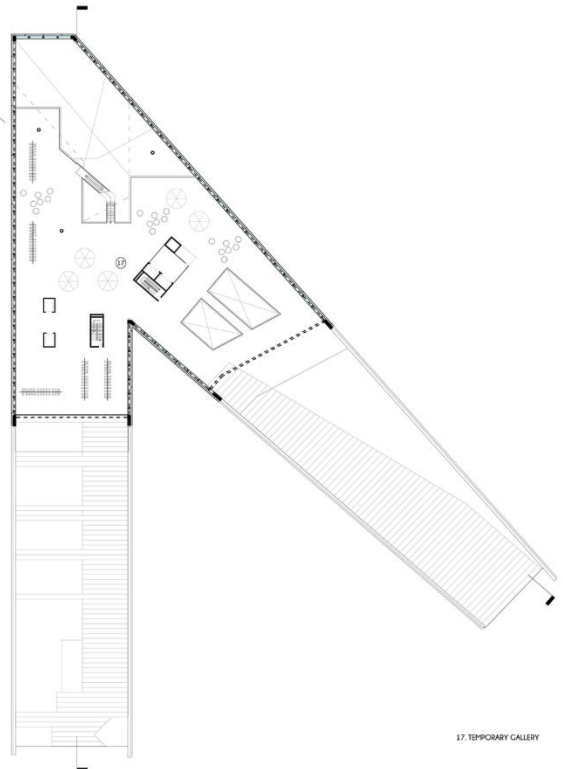

- 17. TEMPORARY GALLERY

Floor Level Plans

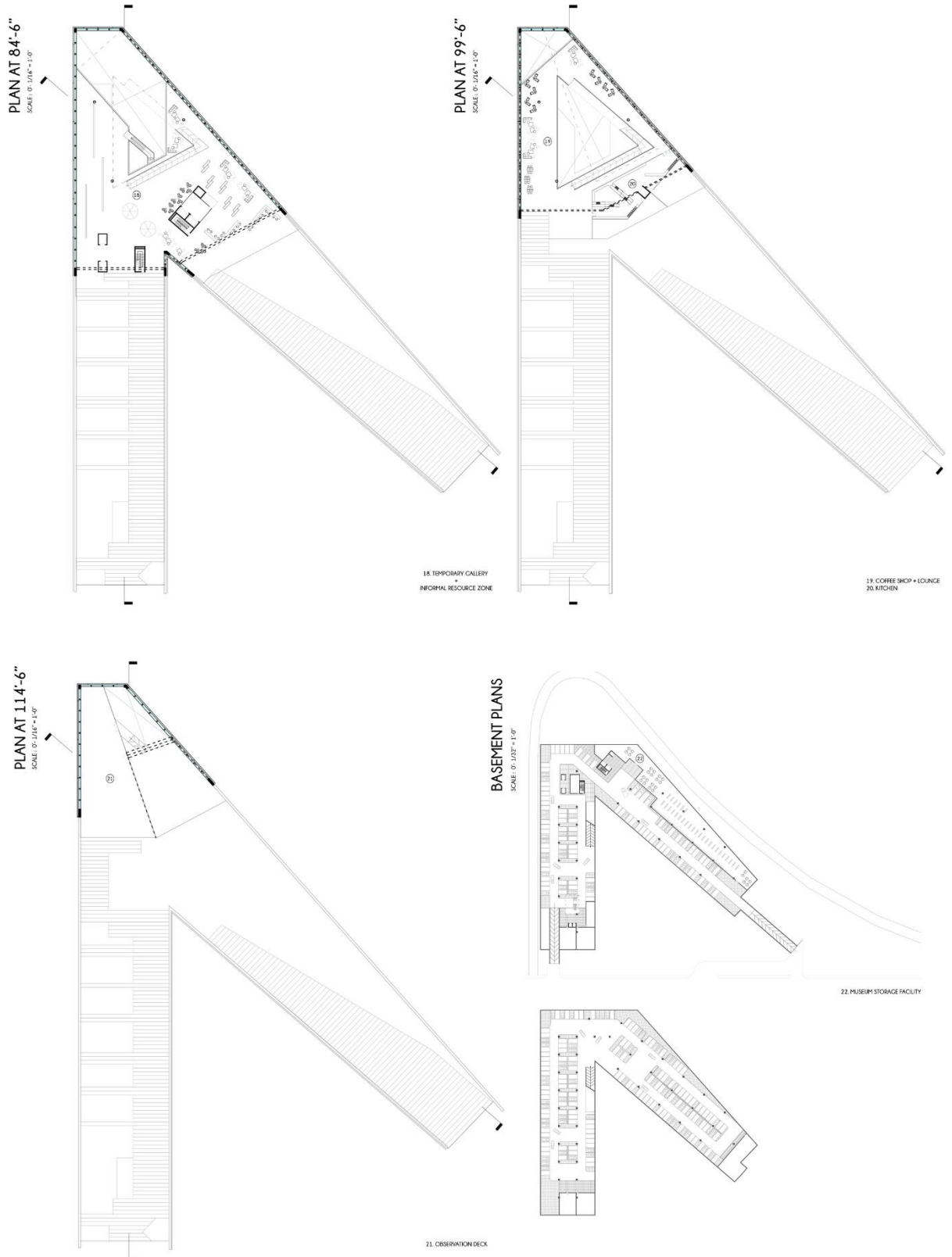

Floor Level Plans

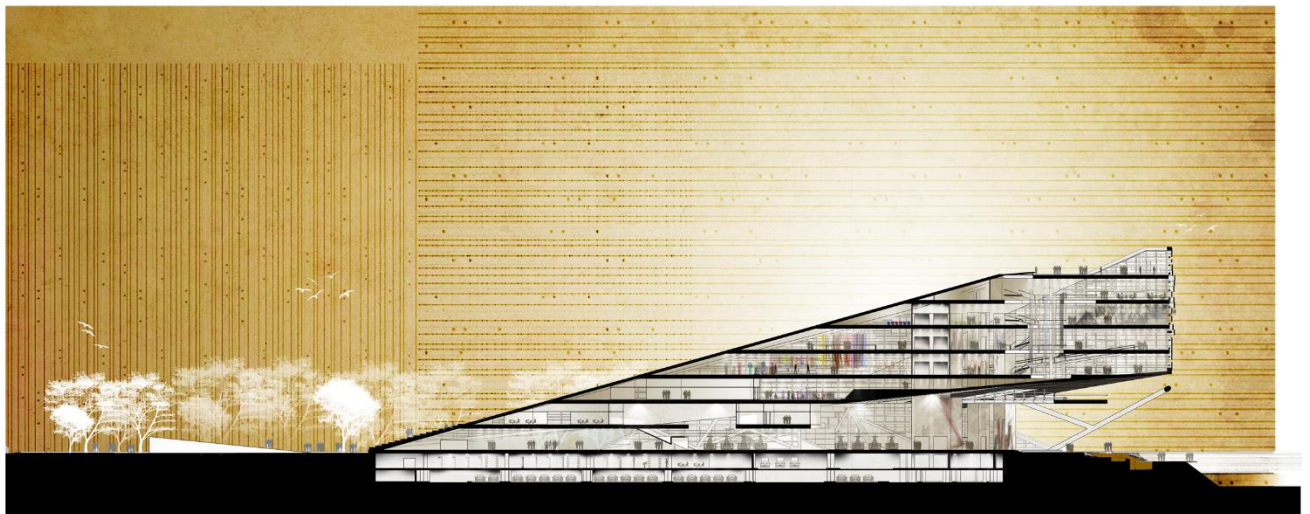
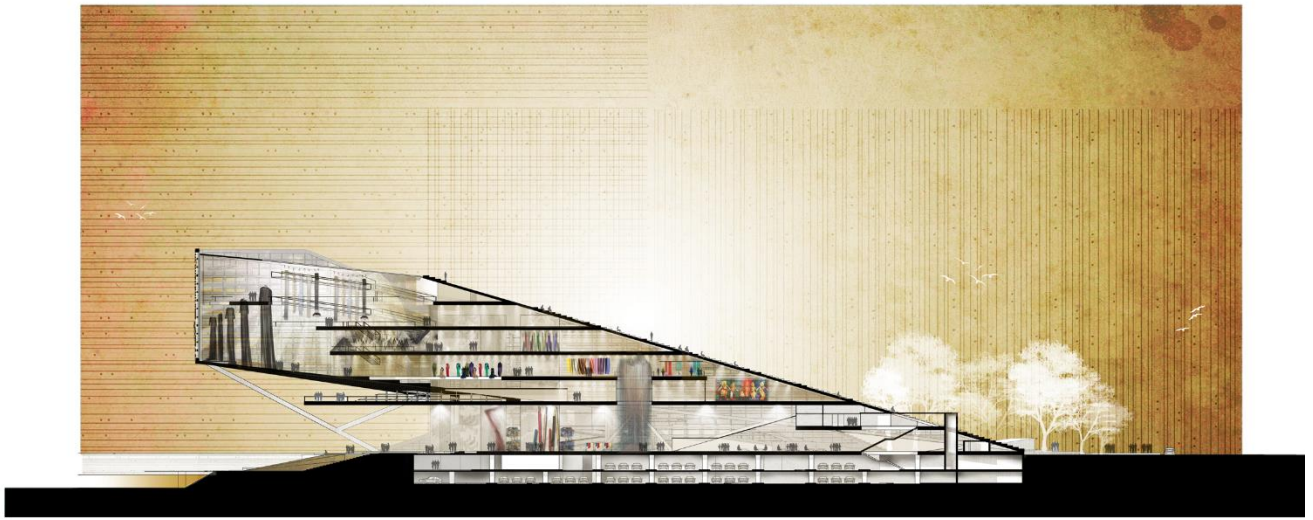

Sections

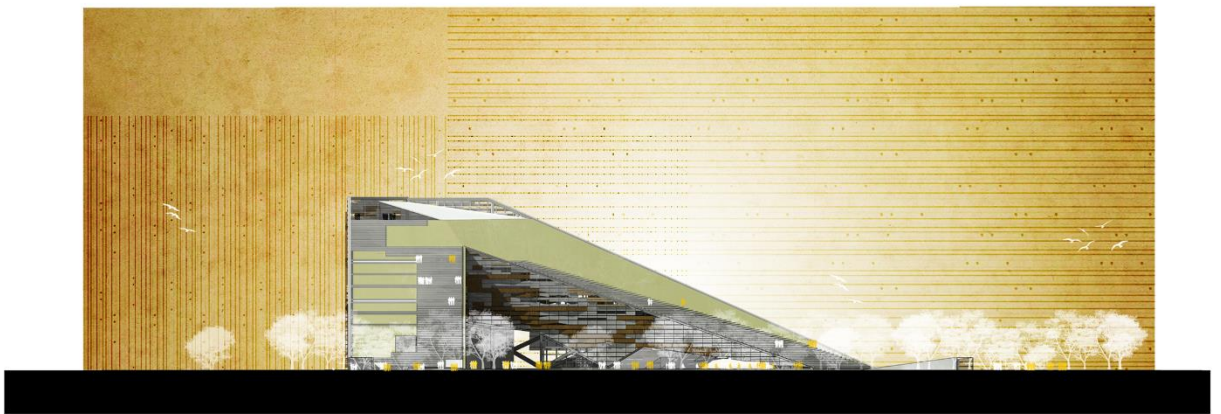
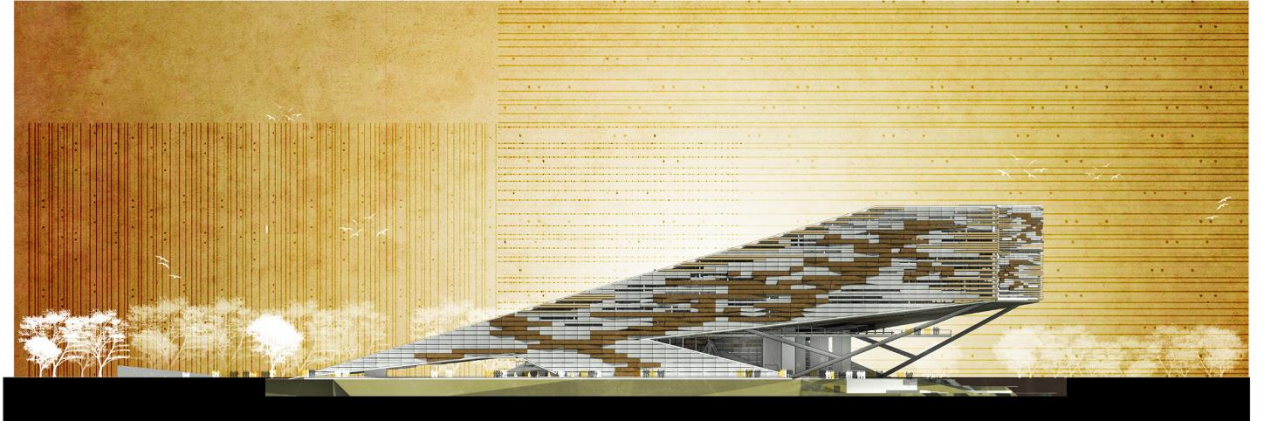

Elevations

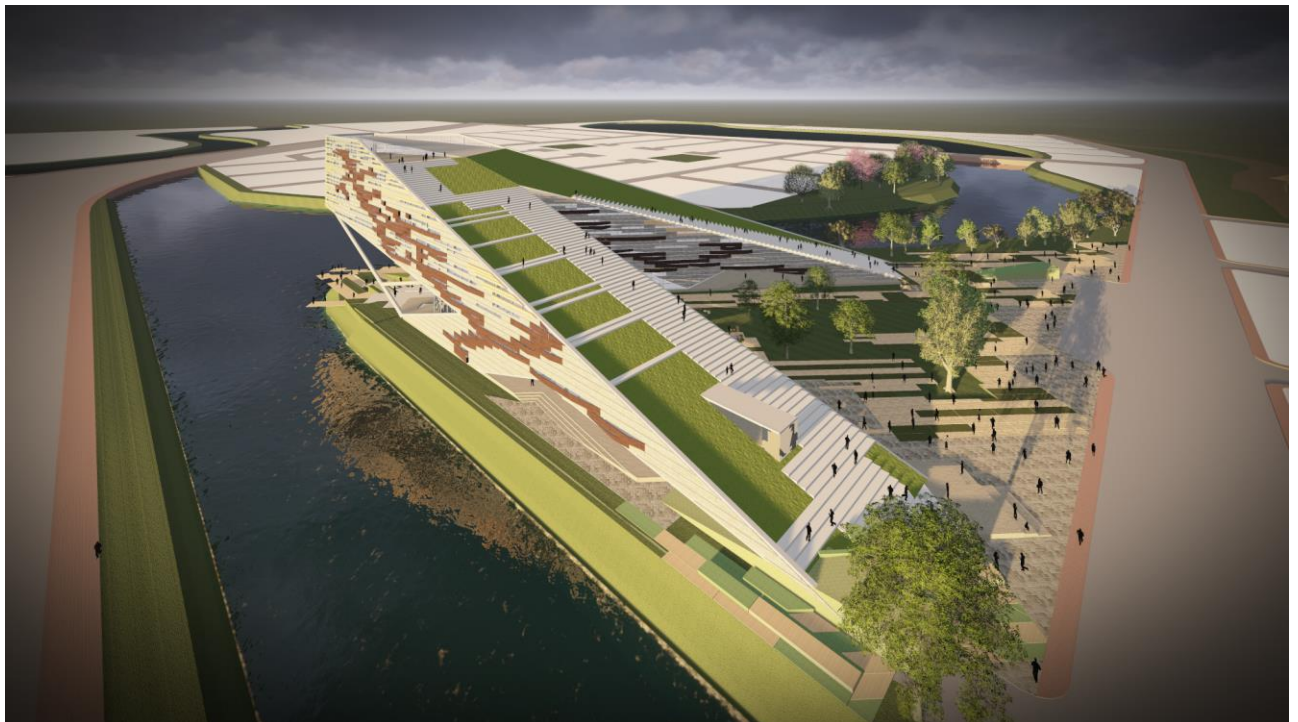
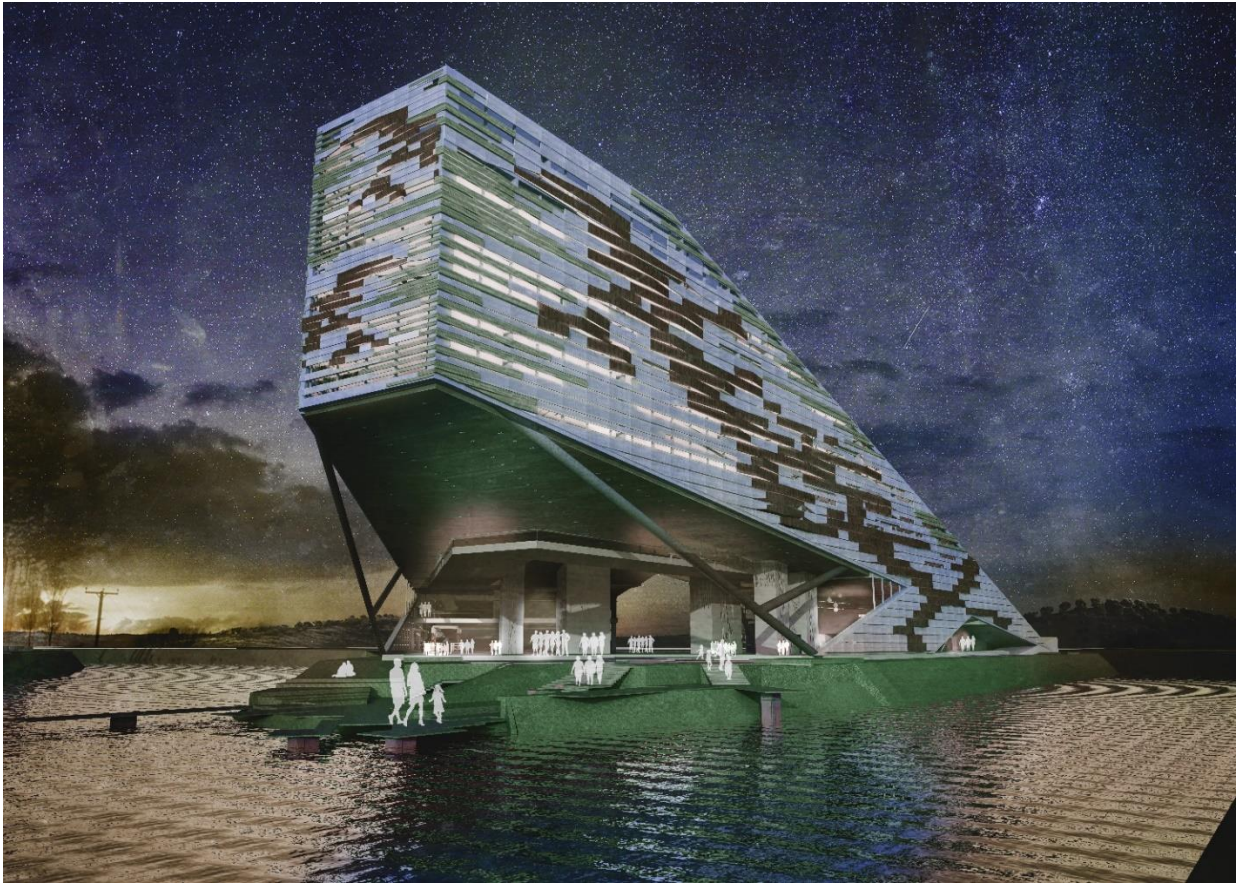

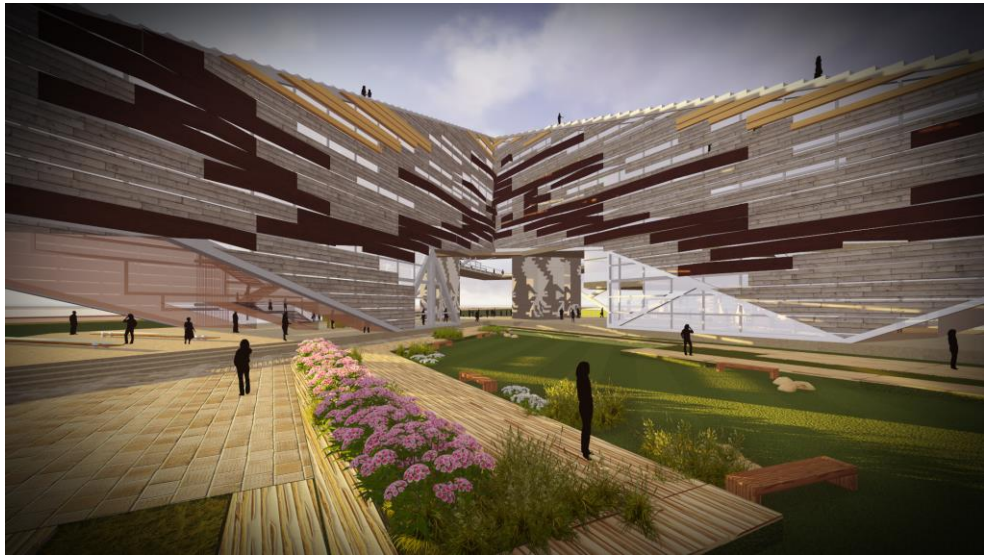

6.5 Final Design Model

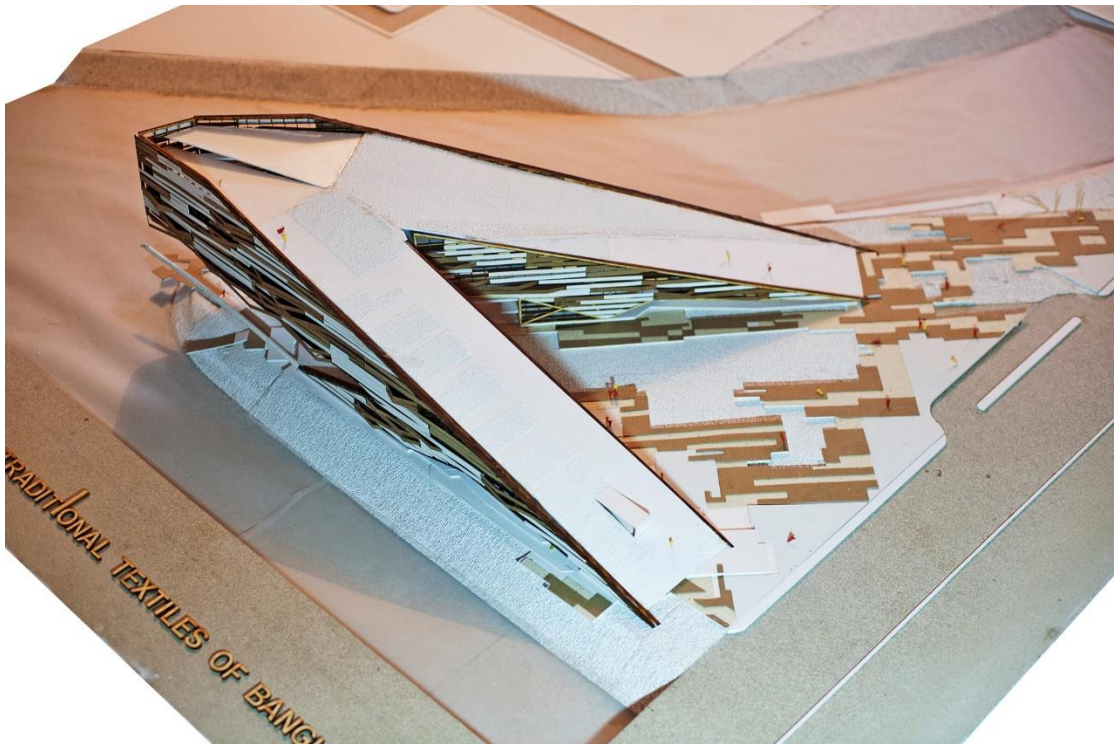

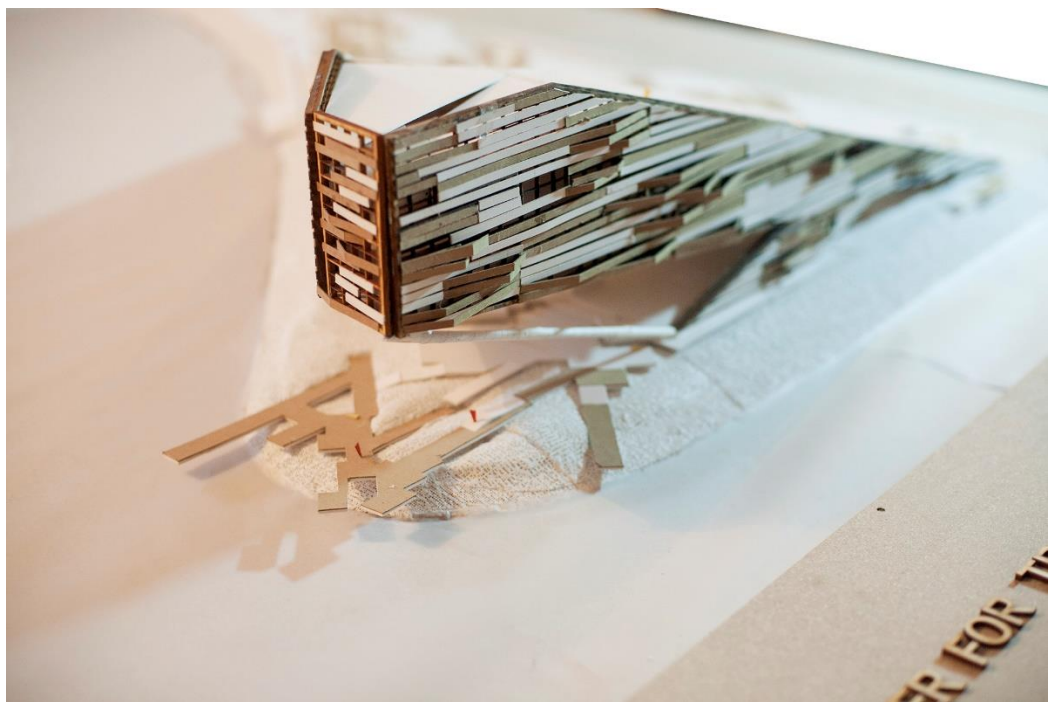

CONCLUSION

The learning acquired through this journey of making this project meet its ultimate end, only hopes to make people realize the true worth of our heritage and is consequently dedicated to all those people related to this craft for generations. The design is a contemporary and abstract interpretation of the elements that make our handloom textiles so very unique. Such a project only entails to bring proper attention and provide a strong platform for showcasing the delicate and glorious past and present of our handloom industry, and have a strong positive impact in its future.

REFERENCES

- Interviews conducted with
 - Monira Emdad, CEO, Tangail Sharee Kutir
 - Maheen Khan, CEO, Mayasir
 - Ratan Basak, Proprietor and Owner, New Chondreshor and Co., Pathral, Tangail
- http://www.dailymotion.com/video/xqvz9g_jamdani-an-ancient-craft_news
- <http://www.newmuseum.org/artspaces/view/britto-arts-trust-1>
- <http://bangladeshtextileresidency.wordpress.com/>
- <http://www.demotix.com/news/552586/mirpur-benarasi-sharee-industries/all-media>
- <http://bn.wikipedia.org/wiki/%E0%A6%9C%E0%A6%BE%E0%A6%AE%E0%A6%A6%E0%A6%BE%E0%A6%A8%E0%A6%BF>
- <http://www.kmomamuseum.org/about-kmoma/architecture/index.html>
- http://afasiaarq.blogspot.com/2013/11/herzog-de-meuron_25.html
- <http://www.floornature.com/projects-learning/project-tao-museum-of-handcraft-paper-7594/>
- www.banglapedia.org
- <http://www.craftrevival.org/>
- Joseph De Chiara, “Time-saver standards for building types”, 4th Edition.
- http://www.academia.edu/6243836/AN_ANALYSIS_OF_PRESENT_SCENARIO_OF_HANDLOOM_WEAVING_INDUSTRY_IN_BANGLADESH
- <http://www.weather-and-climate.com/average-monthly-Rainfall-Temperature-Sunshine,Dhaka,Bangladesh>