

# **IOT BASED MICROORGANISM DETECTION AND FILTRATION SYSTEM**

**By**

Nuren Tahsin

18321047

Md.Shamsur Rahman Shishir

18321020

Md.Shakil Mahmud

18321006

Md.Mostofa Rahman Jafree

18321008

A Final Year Design Project(FYDP) submitted to the Department of Electrical and Electronic Engineering in partial fulfillment of the requirements for the degree of B.Sc. in Electrical and Electronic Engineering.

## **Academic Technical Committee (ATC) Panel Member:**

Dr. Abu S. M. Mohsin, PhD(Chair)

Associate Professor, Department Of Electrical and Electronics Engineering  
Brac University

Taiyeb Hasan Sakib(Member)

Lecturer, Department Of Electrical and Electronics Engineering  
Brac University

Ehsanul Karim(Member)

Lecturer, Department Of Electrical and Electronics Engineering  
Brac University

Electrical and Electronic Engineering

Brac University

January 2023

## **Declaration**

It is hereby declared that

1. The Final Year Design Project (FYDP) submitted is my/our own original work while completing degree at Brac University.
2. The Final Year Design Project (FYDP) does not contain material previously published or written by a third party, except where this is appropriately cited through full and accurate referencing.
3. The Final Year Design Project (FYDP) does not contain material which has been accepted, or submitted, for any other degree or diploma at a university or other institution.
4. I/We have acknowledged all main sources of help.

### **Student's Full Name & Signature:**

---

Nuren Tahsin  
18321047

---

Md.Shamsur Rahman Shishir  
18321020

---

Md.Mostofa Rahman Jafree  
18321008

---

Md.Shakil Mahmud  
18321006

## **Approval**

The Final Year Design Project (FYDP) titled Design And Implementation Of IoT based microorganism detection and filtration system.

1. Nuren Tahsin (18321047)
2. Md.Shamsur Rahman Shishir (18321020)
3. Md.Mostofa Rahman Jafree (18321008)
4. Md.Shakil Mahmud (18321006)

of fall, 2022 has been accepted as satisfactory in partial fulfillment of the requirement for the degree of B.Sc. in Electrical and Electronic Engineering on 23 January 2023.

### **Examining Committee:**

Academic Technical  
Committee (ATC):  
(Chair)

---

Dr. Abu S. M. Mohsin, PhD  
Associate Professor, Department Of Electrical and Electronics  
Engineering  
Brac University

Final Year Design Project  
Coordination Committee:  
(Chair)

---

Dr. Abu S. M. Mohsin, PhD  
Associate Professor, Department Of Electrical and Electronics  
Engineering  
Brac University

Department Chair:

---

MD.Mosaddequr Rahman, PhD  
Professor and Chairperson, Department Of Electrical and  
Electronics Engineering  
Brac University

## **Ethics Statement**

Our final year design project report contains 1% plagiarism .

## **Abstract/ Executive Summary**

This abstract presents an IoT-based microorganism detection and filtration system. The system utilizes sensor technology to detect the presence of microorganisms in air using masks and a filtration mechanism to remove them. The sensor data is transmitted to a remote device via IoT connectivity, allowing for real-time monitoring and analysis of the air quality. The system is designed to be highly efficient and cost-effective, making it a viable solution for large-scale implementation in various settings, including homes, industries, school, medical etc. The system is also designed to be user-friendly and easy to install, making it accessible to a wide range of users. This proposed IoT based microorganism detection and filtration system has the potential to improve the quality of life for communities by providing access to air quality monitoring.

**Keywords:**IoT;microorganism;air quality; user friendly;real-time monitoring; filtration system.

## **Dedication**

Special thanks to our ATC Chair Dr. Abu S. M. Mohsin sir for guiding us throughout the project.

## Acknowledgement

We would like to extend our heartfelt appreciation to BRACU Optica for their invaluable support in this project. The financial and technical assistance provided by BRACU Optica has been instrumental in the success of this project. Their guidance and expertise have been greatly beneficial to our team and we are deeply grateful for their partnership. We would like to express our sincere gratitude to BRACU Optica for their continued support.



We also would like to express our sincere gratitude to Stanford University for providing financial support for this project. This funding has been instrumental in allowing us to conduct our research and bring this project to fruition. We are deeply appreciative of the University's commitment to supporting innovative and impactful projects such as ours. Thank you Stanford University for your continued support.



## Table of contents

Declaration	2
Approval	3
Ethics Statement	4
Abstract/ Executive Summary	5
Dedication	6
Acknowledgement	7
Table of Contents	8-14
List of Tables	14-16
List of Figures	16-18
List of Acronyms	19
Glossary	20



Chapter 1 [CO1, CO2, CO3, CO10]	21
1.1 Introduction	21
1.1.1 Problem Statement	21
1.1.2 Background Study	21-23
1.1.3 Literature Gap	23
1.1.4 Relevance to current and future Industry	23
1.2 Objectives, Requirements, Specification, and constant	24
1.2.1 Objectives	24
1.2.2 Functional and Nonfunctional Requirements	25
1.2.2 Specifications	24-27
1.2.3 Technical and Non-technical consideration and constraint in design process	28
1.2.4 Applicable compliance, standards, and codes	28-29
1.3 Summary of the proposed project	29-31
1.4 Conclusion	31

Chapter 2: Project Design Approach [CO5, CO6]	32
2.1 Introduction	32
2.2 Identify multiple design approach	32
2.3 Describe multiple design approach	32
1. Particle Filtration System Using IR Sensor	33-34
2. Particle filtration system with Air Quality Indicator sensor	35
3. IOT Based Particle Filtration System	35
2.4 Analysis of multiple design approach	35
2.5 Conclusion	35
Chapter 3: Use of Modern Engineering and IT Tool. [CO9]	36
3.1 Introduction	36
3.2 Select appropriate engineering and IT tools	36
3.3 Use of modern engineering and IT tools	37-40
3.4 Conclusion	40

Chapter 4: Optimization of Multiple Design and Finding the Optimal Solution. [CO7]	41
4.1 Introduction	41
4.2 Optimization of multiple design approach	41-48
1. Particle Filtration System Using IR Sensor	42
2. Particle filtration system with Air Quality Indicator sensor	43-44
3. IOT Based Particle Filtration System	44-47
4.3 Identify optimal design approach	48-51
4.4 Performance evaluation of developed solution	51-57
4.5 Conclusion	57

Chapter 5: Completion of Final Design and Validation. [CO8]	58
5.1 Introduction	58
5.2 Completion of final design	58-66
5.1.1 Design Methodology and Design Process	
5.1.2 Data Collection and Analysis	67-69
5.3 Evaluate the solution to meet desired need	69-72
5.1.3 R&D lab monitoring and mask efficiency	72
5.4 Conclusion	72
Chapter 6: Impact Analysis and Project Sustainability. [CO3, CO4]	73
6.1 Introduction	73
6.2 Assess the impact of solution	73
6.3 Evaluate the sustainability	74-75
6.3.1 Maintainability and Manufacturability	
6.3.2 Sustainability	
6.4 Conclusion	75
Chapter 7: Engineering Project Management. [CO11, CO14]	76
7.1 Introduction	76
7.2 Define, plan and manage engineering project	76-80
7.3 Evaluate project progress	80-81
7.4 Conclusion	82

Chapter 8: Economical Analysis. [CO12]	83
8.1 Introduction	83
8.2 Economic analysis	83-84
8.3 Cost-benefit analysis	84-87
8.4 Evaluate economic and financial aspects	87
8.5 Conclusion	88
Chapter 9: Ethics and Professional Responsibilities CO13, CO2	89
9.1 Introduction	89
9.2 Identify ethical issues and professional responsibility	89-90
9.3 Apply ethical issues and professional responsibility	90-92
Legal Consent	92
Risk Management and Contingency Plan	
Safety Consideration	
9.4 Conclusion	93
Chapter 10: Conclusion and Future Work	94
10.1 Project summary/Conclusion	94
10.2 Future work	95
Chapter 11: Identification of Complex Engineering Problems and Activities.	95
11.1: Identify the attribute of complex engineering problem (EP)	96
11.2: Provide reasoning how the project address selected attribute (EP)	97-98
11.3 Identify the attribute of complex engineering activities (EA)	98-99
11.4 Provide reasoning how the project address selected attribute (EA)	99

References	100-102
Logbook	103-107
Appendix	108-113

**List of tables:**

Table 1:Functional and Nonfunctional Requirements	25
Table 2:Component Details	25-27
Table 3:Applicable compliance, standards, and codes	29-31
Table 4:Analysis of multiple design approach	35
Table5: Basis of analysis for IR	42
Table6:Basis of analysis for AQI system	44
Table7:Basis of analysis For IOT based system	48
Table8:Performance evaluation of developed solution	51
Table9:Weighted Decision Matrix	52
Table10:IR sensor cost	53
Table11:Filtration system using Air Quality Indicator sensor cost	54
Table12:IoT based filtration system cost	55
Table 13:SWOT Analysis of Optimal Design Solution	57
Table14:Data without placing the mask in chamber	63

Table15:Data placing mask in chamber	63
Table16:Data After using mask 6-7 hours	64
Table17:Data After disinfecting mask	65
Table18:Data placing mask in chamber	66
Table19:Data After using mask 6-7 hours	66
Table20:Data After disinfecting mask	66
Table21: Project Object	70
Table22 : Evaluate the Model results with the desired needs	70
Table23: Analysis of collected data	71
Table24: Analysis of collected data	71
Table25: Analysis of mask efficiency	72
Table:26 Weighted Decision Matrix For Technology Analysis	75
Table27:Project plan evaluation	81
Table28:Cost analysis of Multiple design approaches	84
Table29: Cost analysis of multiple designs	85
Table30: Evaluate economic and financial aspects	87
Table 31:Risk management	92
Table32: Attributes of Complex Engineering Problems (EP)	97

Table33 Attribute of complex engineering activities (EA)	99
Table 34: Team logbook -400P	103-104
Table 35: Team logbook -400D	105
Table 36: Team logbook -400C	107-108

### List of Figure:

Fig: 1 Particle Filtration Using IR	33
Fig2:Particle filtration with particle counter sensors	33
Fig3: IOT Based Particle Filtration	34
Figure4:Work flow diagram of proteus	39
Figure5:Workflow of selected tools for final prototype	40
Figure6:Simulation model of Particle Filtration Using IR	41
Figure7:Simulation result of Particle Filtration Using IR	42
Figure8: Simulation model of Particle filtration with air quality indicator sensors	43
Figure9: Simulation model of Particle filtration with particle counter sensors	43
Figure10:3D model of IOT Based Particle Filtration	44
Figure11:Simulation result of IOT Based Particle Filtration	45



Figure12:Simulation result of IOT Based Particle Filtration	45
Figure13:Temperature and humidity result in Thingspeak	46
Figure14 Figure 14:2-D plot of particles	46
Figure15:Graph for Temperature, humidity Particles monitoring	47
Figure16:Statistics of PMS7003 and SDS011	50
Figure17:Workflow diagram	59
Figure18:Full set-up of IoT Based Microorganism Detection and Filtration System	59
Figure19:Data collection box ( PMS7003,DHT22,MQ131)	60
Figure20:PCB board design	60
Figure21: Vacuum pump XZ-1A	61
Figure22: Mounting chamber	62
Figure23: BLYNK cloud server for monitoring data and efficiency	62
Figure24:LCD monitoring data and efficiency	64

Figure25:Surgical mask	64
Figure26: Disinfecting chamber inside(a) and outside(b) look	65
Figure28:KN95 mask	67
Figure29:Graphical representation of particles for surgical mask(particle size 0.3um-1.00um)	67

Figure30:Graphical representation of particles for surgical mask(particle size 2.5um-10.0um)	68
Figure31:Graphical representation of particles for KN95 mask(particle size 0.3um-1.00um)	68
Figure32:Graphical representation of particles for KN95 mask(particle size 0.3um-1.00um)	68
Figure33:Graphical representation of particles for surgical mask(particle size 2.5um-10.0um)	69
Figure34:Graphical representation of Ozone gas(a) and device placed inside disinfecting chamber(b)	69
Figure35: Project Plan of EEE-400P	76
Figure36: Project Plan of EEE-400D	77
Figure37: Project Plan of EEE-400C	78
Figure38: Work duration of EEE-400P	78
Figure39: Work duration of EEE-400D	79
Figure40: Work duration of EEE-400C	79
Figure41:Mask Particle Filter Efficiency PFE Tester AFT-100	86
Figure42:Approval form	90
Figure43: Public consent form	91

## List of Acronyms

IEEE-	Institute of Electrical and Electronics Engineers
IoT-	Internet of Things
PM sensor-	Particulate matter sensor
USB-	Universal Serial Bus
ESP-	Espressif Systems
PCB-	Printed Circuit Board
IR-	Infrared radiation
URAT-	Ultrasonic Rock Abrasion Tool
DHT-	Dihydrotestosterone
LCD-	Liquid Crystal Display
LED-	Light Emitting Diode
OPC-	Optical Particle Counter
TEMO-	Tapered element oscillating microbalance
AQI-	Air Quality Index

## Glossary

IoT	"Internet of Things" refers to the network of physical devices, vehicles, buildings, and other items embedded with electronics, software, sensors, and connectivity which enables these objects to connect and exchange data with each other, the internet and other devices
Sensor	a device that detects changes in a physical quantity and converts it into a signal that can be read by an instrument or device.
Cloud server	a virtual server that runs on a cloud computing platform, created and managed using software, and they can be accessed remotely over the internet.
C programming	C is a general-purpose, procedural programming language closer to machine language and provides more control over the computer's hardware.
Data set	a collection of data, often in tabular form, that is organized for a specific purpose or use.

## Chapter 1[CO1, CO2, CO3, CO10]

### Introduction

#### 1.1 Introduction:

Masks should be worn as part of an all-encompassing plan of action to stop the spread of disease and save lives. 95% of the nanoparticles that can be transported six feet in the air are reduced by wearing a fresh mask. It's vital to remember that the mask works best when the infected individual is wearing it, whether they are symptomatic or asymptomatic. Taking care of yourself: Again, we have no idea how many carriers of the virus we come into contact with every day, therefore we can also be protected by donning a mask. Our design aim is to implement a smart microorganism detection and filtration efficiency monitoring system which will measure/identify the efficiency of a face mask before and after disinfecting it by a face mask particle filtration device.

##### 1.1.1 Problem Statement:

IoT based microorganism detection and filtration system.

##### 1.1.2 Background Study:

Through our studies we have come to know that in our country people mostly use their old or previously used masks again and again. Moreover, those masks might be infected with some kind of random microorganism which can be harmful for them and also for surrounding peoples. Most of the people are unaware about the performance of their daily masks. On the other hand, maximum people wash their masks with hot water, soap or with other cleaning products which can harm masks fabrics and decrease the efficiency significantly.

Coronavirus has already affected over 650 million people and killed over 6.5 million people in the whole world. Individual containment, using a high-performance mask, is an effective solution to safeguard the populace in this circumstance. In reality, the major objective of wearing a face shield is to prevent inhaling as well as to capture airborne nanoparticles (environmental or artificial) and microbial substances (bacteria, virus, prions, and fungi)[1]. Environmental (volcanic activity, dust storms, naturally occurring wildfires) and artificial (industrial pollution) airborne particles are on a nanoscale size. The severe influence of nanoparticle respiration on respiratory and cardiovascular illnesses has been demonstrated in several investigations. Breathing in tiny microparticles (particles less than 2.5 $\mu$ m) also claimed the lives of not less than 9 million people in 2015[1]. Besides, particles in the air have been the subject of numerous research [2]. These microbes can pose a danger to health; also, safety against pathogenic microorganisms has long been a priority, and research has consistently attempted to increase safety.[1].

Health professionals all across the world have concluded that wearing a mask can help prevent the illness from spreading between people. While this is true, some masks, notably

N95 masks, are thought to be far more effective in reducing the chance of exposure. To prevent suspended particles from entering or leaving the wearer's respiratory system, filtering face shield respirators, healthcare masks, and other face masks are utilized in a number of situations, including industry, medical, and public health settings[3].

The importance of determining the filtration method is great because of the considerable as well as exterior variables that have a critical impact on filtration efficiency. Only by explaining and comprehending these systems will it be feasible to improve the mask's design and filtering. One of the subjects of attention this term has been the investigation of particle filtration method and clarification of how the nanoparticles are placed. Some of the techniques utilized in mask filtration are gravitational precipitation, inertial impaction, interception, diffusion, electrostatic attraction, and thermophoresis. When you add efficiency to the effects of the separate filtration processes, you get the total efficacy of the filter. As a result, the first step must be to examine the involvement of individual particle filtration processes.[1].

The current research focuses on filtering efficiency. The particulate filtration efficiency (PFE), often known as the PRE, is specified as the fraction of nanoparticles identified downstream and upstream of the mask[4]. Such experiments are carried out with 0.1 μm polystyrene latex particles dissolved in water, and the aerosols are generated using a particle generator. An alternate approach employs NaCl aerosol with particle sizes ranging from 10 nm to 10 μm. (average diameter of 300 nm). Staphylococcus aureus (size ranges from 3.0-0.3 μm) is commonly used for bacterial purification. Different kinds of viruses are employed to evaluate viral filtering ability, which isn't a conventional test methodology.[5,6]

Designing and elucidating the method through which bio-aerosols penetrate the mask, on the other hand, is crucial. When polluted particles and germs reach the mask's exterior surface, this becomes crucial. If the germs/microorganisms that have colonized it are not destroyed by the surface, the polluted fragment can permeate the facemask by numerous methods like capillaries [1].

Moreover, when a facemask is exposed to contaminated droplets on its exterior surface, it can become a virus collector. Given that microbial pathogens will indeed be present on the surface and within the mask for a long stretch of time while still being used, it is plainly damaging and undesired if they can live and remain available in the hot and moist environment inside the masks. Given the conditions of the facemask and the extreme moisture levels and temperature produced during the respiratory process, the formation of vapor in the facemask would hasten the process of microbe piercing and dispersion to the interior regions of the mask. The phenomenon has been studied as a physical system that includes both warmth and weight transmission in porous materials by simulations and numerical research.[1].

To avoid such occurrences, it is critical to investigate the bio-particle and particle transmission processes in the mask, as well as to observe the mask's layout and utilization in light of these mechanisms. The goal of this review was to look into the mechanisms of particle filtering by masks and the factors that influence them, such as face velocity or

airflow, steady or uneven flow patterns, particle charge state, respiration frequency, relative humidity and temperature, and loading time[1].

So, here our main vision is to establish a reusable system which can lead us to successfully reduce the number of harmful disposal masks from the environment and also create a cost efficient system for uses of face masks. Also, by this efficient testing we want to create awareness among the people to use a better quality mask like KN95 which have a high efficiency rate and provide best protection from virus, dust and other harmful nano-particles than other low quality and cheap masks.

### **1.1.3 Literature Gap:**

Most of the filtration efficiency monitoring setups only focus on just measuring the efficacy of a face mask. This idea can be extended by adding a micro-particles detection system. Moreover, the efficiency test result data will be stored in the cloud so that it can be accessible anywhere, anytime. Additionally, testing of PPE and other medical safety components will be possible by this micro-particle detection and filtration efficiency monitoring system device. All of these will be done on the basis of IoT systems in this project. Though, most of the researchers are still valid researchers don't bother about cost or how to make a cost effective device which could be very much effective if they could conduct some economical experiments. Some of the particle filtration efficiency devices were made with very complex and rare sensors which are very difficult to find. If a brief idea or concept of alternative approach of the same method can be available with those it can have more potential.

### **1.1.4 Relevance to current and future Industry:**

Initially, the plan is to test face masks through the particle filtration efficiency test setup. After successful implementation, it is obvious that further extension of the setup will make it capable of testing other medical safety arrangements like PPE and other equipment in future.

Moreover, the most purposive aim is to use this particle filtration efficiency test setup to hospitals and medical centers as the doctors, other staff and patients need more disinfected face masks and other safety equipment than others. In addition, schools, colleges, garments and any type of industries can use this surveillance system. Hospitals are considerably the safest places and if the device gets successfully executed in medical sectors, hopefully in near future these kinds of setup will be more desired in other aspects as well.

## **1.2 Objectives, Requirements, Specification and constant**

### **1.2.1. Objectives**

#### **1. Design a microorganism detector**

In this design, in order to describe micro-particles, the AQI system is being used. The frame employs a molecule counter detector that is controlled through a WiFi microcontroller unit capable of Iot regulator so this data can be covered with an app/website. This will affect easy and smart vacuity of data at any time. Likewise, with the help of the molecule counter it will be suitable to cover molecule transmission through the mask via which the device is going to cover the molecule size.

#### **2. Determine the efficiency performances of Different masks**

Effective test setup will be suitable to determine if the mask has maintained filtration effectiveness ahead and after disinfecting it. From the data it will be possible to compare the filtration effectiveness between different types of masks like KN95, N95 and surgical masks.

#### **3. Store Data and sort the reusable mask**

Collected data will be saved in a pall so that from this observation a suitable set of comparison between different masks is possible approved by different countries to see which mask meets the conditions substantially worldwide in this covid- 19 situation. Also sorting of applicable masks will be easier by using this data for exercise.

Eventually, it is clearly visible that through this low cost microorganism discovery and filtration device comparison of the effectiveness performances of masks before and after disinfecting can be easily executed. Also it will be feasible to find out the effectiveness of different masks by disinfecting them in different ways and a feedback can be given on which disinfecting way is better than others.

### **1.2.2 Functional and Nonfunctional Requirements:**

For our project, we had to adhere to a few system- and component-level criteria. Table1 lists the functional and nonfunctional requirements at the system and component levels. Details of each component are also provided in Table2.



**Table 1:Functional and Nonfunctional Requirements**

	System level	Component Level
<b>Functional</b>	1. Mounting chamber	1.A box or spherical shaped hard plastic ball 2. 100 cm <sup>2</sup> area
	2.Control system	1.Vacuum pump XZ-1A 2.Air flow controller valve
	3.Data collection device	1.PMS7003 2. DHT22 digital temperature humidity sensor. 3. MQ-131 Sensor CO Ozone Gas Sensor Module Detector Gas Detection Module
	4.Algorithm Unit	1.Arduino Integrated Development Environment 2.C-programming language
	5. Hardware System	1.Wifi microchip ESP8266 D1 mini 2.USB port 3.Arduino nano
<b>Non Functional</b>	1.Mask Monitoring using image processing	1.Camera 2.Machine learning
	2.Data Display	1.LCD display 2.IOT cloud

**Table 2:Component Details**

Components	Details	Purpose
Plantower PMS7003 sensor	<ul style="list-style-type: none"> <li>● Run of measurement:0.3µm ,1.0µm,2.5 µm ,10 µm .</li> <li>● Data output by means of: UART .</li> <li>● Effective Run: 0...500 µg/m<sup>3</sup> .</li> <li>● Power Supply: 5 V</li> <li>● Interface Level: 3,3 V</li> <li>● Active Current: ≤100 mA</li> <li>● Standby Current: ≤200 µA</li> <li>● Working Temperature Extend: -10...+60°C</li> <li>● Working Humidity Extend: 0...99%</li> <li>● MTTF: ≥3 years</li> <li>● Size: 48 x 37 x 12 mm</li> </ul>	Air Particle counting

Vacuum pump XZ-1A	<ul style="list-style-type: none"> <li>● Control Source: Electric</li> <li>● Structure: Single-stage Pump</li> <li>● Voltage: 220 V~50HZ/ 110 V~60HZ</li> <li>● Power:180 W,1/4 HP</li> <li>● Horsepower:1/5 HP</li> <li>● Material: Stainless Steel</li> <li>● Motor:0.18 KW</li> </ul>	Air Suction
MQ-131 Sensor CO Ozone Gas Sensor Module Detector Gas Detection Module	<ul style="list-style-type: none"> <li>● Gas Type:MQ-131 Ozone Gas Sensor</li> <li>● Measuring Range:2-10 PPM</li> <li>● Operating Voltage:5</li> <li>● Power Supply: 5</li> <li>● Pin Definition:4</li> <li>● Digital Output :Yes</li> </ul>	Ozone gas detection
Air flow controller valve	<ul style="list-style-type: none"> <li>● OperatingTemperature:-20~110</li> <li>● Flow Rate:0.6-70L/min</li> <li>● Measure medium:water/ oil/ air</li> <li>● Output:switch signal,No</li> <li>● Contact capacity:24VDC/220VAC, 100mA</li> <li>● Maximal Withstand Voltage:50 bar / 400 bar</li> <li>● size: 20X15X10 cm</li> <li>● weight:1.000 kg</li> <li>● Operating Temp.: -20~110°C</li> </ul>	Air flow control
DHT22 Temperature and Humidity sensor	<ul style="list-style-type: none"> <li>● Operating Voltage:3 ~ 5.5V</li> <li>● Accuracy resolution:0.1</li> <li>● Humidity range:0-100%RH</li> <li>● Temperature range:-40~80°C</li> <li>● Humidity measurement precision:±2%RH</li> <li>● Temperature measurement precision:±0.5°C</li> <li>● Length (mm):43</li> <li>● Width (mm):15</li> <li>● Height (mm):10</li> <li>● Weight (gm):7</li> </ul>	Temperature and humidity monitoring

ESP8266 D1 mini	<ul style="list-style-type: none"> <li>● Clock speed:80/160 MHz</li> <li>● SRAM: 64 kB</li> <li>● Memory: 4 MB</li> <li>● Wireless standard: 802.11 b/g/n</li> <li>● Bluetooth: Classic / LE</li> <li>● Data interfaces: UART / I2C / SPI / DAC / ADC</li> <li>● Operating voltage: 3.3 V (can be operated via 5-V micro-USB)</li> <li>● Operating temperature: -40 to 125°C</li> <li>● Dimensions: 34mm x 26mm</li> </ul>	Wireless wifi for data transmission
Arduino Nano	<ul style="list-style-type: none"> <li>● Operating voltage for the ATmega328P microcontroller - 5 volts</li> <li>● input voltage for the Vin pin - 12 volts,</li> <li>● 6 analog input- pins (A0 – A5)</li> <li>● 14 Digital I/O Pins (Out of which 6 provide PWM output)</li> <li>● I/O pin DC currents of 40 mA; 3.3 V pin DC currents of 50 mA</li> <li>● 32 KB Flash Memory (2 KB is used for Bootloader)</li> <li>● 2 KB of SRAM, 1 KB of EEPROM, and 16 MHz of clock speed.</li> <li>● Communication: SPI, USART, and IIC</li> </ul>	Microcontroller used for processing the code
USB port	<ul style="list-style-type: none"> <li>● Material : Aluminum Alloy</li> <li>● Output: 3 USB 3.0 Por-Ts:5Gbps, (Reverse Compatible With US 82.0. USB1.0)</li> <li>● 1 Port PD3.0 Type C: Up To 100W</li> <li>● 1 HDMI 2.0 Port: Support 41(301-17 / HOM11.4</li> <li>● (Reverse Compatible With HDMI 1.3/1.2)</li> <li>● Support Output Via HDMI</li> <li>● Compatible: All Laptops With Type-C Port, Android Phone, IPod Pro</li> </ul>	External power supply and data transfer

## Conflicting Requirements

A necessity might conceivably struggle with any other prerequisite. In case, two conditions collide with each other and an arrangement is constructed to fulfill as if it were one of them, the arrangement will have a negative effect on the other. The taking after clashes can be in the design.

In the design PMS7003 is being used which can detect up to 0.3  $\mu\text{m}$  sized patches but there are some detectors that can detect up to 0.1  $\mu\text{m}$  sized patches although those detectors are expensive but the plan is to make a cost effective system. As a result, those detectors will be out of budget because of cost.

### 1.2.2 Specifications:

**Mask efficiency measurement:** BRAC University has designed a disinfecting chamber which was formerly installed in the R&D lab. Initially we want to make such a filtration system which can test around 1 mask per minute so the test run time is 60 seconds. To find the mask efficiency we followed a rule. The filtration efficiency,  $\eta_{\text{mask}}$ , can be determined from the ratio of particles per unit time detected with,  $N_{\text{mask}}$ , and without the mask attached,  $N_{\text{ambient}}$ , as  $\eta_{\text{mask}} = 1 - (N_{\text{mask}} / N_{\text{ambient}})$  where  $N_{\text{mask}}$  = with mask

$N_{\text{ambient}}$  = without mask. We test different kinds of masks in various conditions. Firstly we took a new surgical mask then tested it and found the efficiency according to law. Then after using a few hours again we tested and got another efficiency thirdly we disinfected the mask and got an efficiency. We found a new surgical mask efficiency rate (98-100)% and after use the rate decreased and got around 94%. Nonetheless after disinfecting we get 95% most of the time. But most of the K95, N95 masks have 96% efficiency rate so our device can check the performance of the mask before and after disinfecting it. Most of the K95, N95 masks have 96% efficiency rate. Also we want to test the regularly used masks of general people incontinently to make them apprehensive of their mask performance.

### Setup area

The standard test area of the mounting chamber is  $14 \times 12 \times 7 \text{cm}^3$  and we're assuming the overall set up will cover  $24 \times 24 \text{inches}^2$ .

### 1.2.3 Technical and Non-technical consideration and constraint in design process:

**Ensuring steady state count of particles:** As we will establish our optimal system in our university laboratory so occasionally it's delicate to insure steady rate of particles. Whereas ordinary room air has sufficient patches of 0.3 m estimate to empower PFE estimations on N95 masks, air- conditioned exploration installation situations regularly have channels that drop the particulate census significantly[11].

**Ensuring Air Flow:**It is additionally critical to keep the PMS7003 sensor box and the input/output connectors totally fixed to avoid any outside discussion being sucked into the box. It will be difficult to test the discussion at the yield port of the sensor, and guarantee that the discussion stream is such that it does not bypass the sensor[11].

**Air Leakage:** In the event if there is a critical spillage of air from the sides of the cover which determines the entrance of patches, and unless the robe is well fixed to guarantee that the patches which enter are those passing through the robe fabric, at that point the quantitative estimations are likely to give incorrect results[11].

**1.2.4 Applicable compliance, standards, and codes:**To conduct this project, we need to follow some international codes and standards. There are few standards in Table3 that we should obey to design our project.

**Table 3:Applicable compliance, standards, and codes**

<b>Component</b>	<b>Standard and Codes</b>	<b>Explanation</b>	<b>Purpose</b>
PMS7003/ DHT22/MQ-13 1	P2700-2017	IEEE Standard for Sensor Execution Parameter Definitions gives a common framework for sensor execution in detail stating units, conditions, and limits. This standard is pointing for sensor progress with computerized I/O meddle. The specific sensors talked about in this standard are the accelerometer, magnetometer, gyroscope combination sensors, weight sensors, mugginess sensors, temperature sensors etc. In this extent one of the errands is to number particles conjointly screen mugginess ,temperature and pressure .We have to utilize distinctive sensors so we ought to take after this code[7].	Proper selection of the sensors
Architectural Framework of the System	IEEE 2413-2019	IEEE Standard for an Structural System for the Web of Things (IoT) is for a plan framework delineation for the Internet of Things (IoT) which alters the widespread standard ISO/IEC/IEEE 42010:2011 is characterized. The designing framework portrayal is convinced by concerns commonly shared by IoT system accomplices over various spaces (transportation, healthcare, Smart System, etc.). A conceptual preface for the thought of things inside the IoT is given and the shared concerns as a collection of architecture perspectives is clarified to form the body of the framework delineation[8].	Proper architectural framework to utilize all the components

Wi-Fi microchip ESP2866 D1 mini	IEEE 1451-99	The IEEE 1451-99 is centered on making a standard for harmonization of Web of Things (IoT) contraptions and systems. This standard characterizes a technique for information sharing, interoperability, and security of messages over an organization, where sensors, actuators and other gadgets can interoperate, regardless of essential communication development[8].	To maintain communication among the components
Framework of Sensor Execution	IEEE P2510	IEEE Standard for Sensor Execution and Quality where Sensors are central to IoT organic frameworks with a tremendous volume of distinctive sensors arranged into a complex framework. IEEE 2700 proposes a common framework for sensor execution assurance, expressing units, conditions and limits is given. IEEE P2510 characterizes quality measures, controls, parameters and definitions for sensor data related to Web of Things (IoT) implementations[8].	To place the sensors properly inside the framework
Reference Model	NOTE 2 (from [ITU-T Y.2060])	Through the misuse of identification, data capture, handling and communication capabilities, the IoT makes full use of things to offer administrations to all sorts of applications, while guaranteeing that security and security necessities are fulfilled[9].	To establish a reference model
Medical Protective Mask	GB 19083-2010	"Specialized Necessities for Therapeutic Defensive Veils" was pronounced by the past Common Organization of Quality Supervision, Evaluation and Disconnect and the National Standardization Organization Committee, and was actualized on Splendid 1, 2011. The standard shows the specialized necessities, test methodologies, signs and illuminating for the utilization of helpful cautious covers, as well as bundling, transportation and capacity. It is suitable to utilize in helpful working circumstances to channel airborne particles and square dots, blood, body fluids, outflows, etc[10].	To compare the disinfected mask according to standards
Technical Requirements for Surgical Mask	YY 0469-2004	"Specialized Prerequisites for Therapeutic Surgical Veils" was announced by the State Food and Cure Organization as a standard for the pharmaceutical industry and was executed on January 1, 2005. This standard demonstrates the specialized prerequisites, test techniques, signs and illuminating for utilization, bundling, transportation and capacity of remedial surgical covers. The standard stipulates that the bacterial filtration capability of covers have to be not less than 95%[10].	To compare the disinfected mask according to standards

Non-powered air-purifying Particle Respirator	GB 2626-2006	"Respiratory Defensive Hardware Self-priming Filter-type Anti-Particulate Respirator" was announced by the past Common Organization of Quality Supervision, Survey and Separate and the National Standardization Organization Committee. It may well be a required standard for the total content and was executed on December 1, 2006. The confirmation objects stipulated inside the standard join all sorts of particulate matter, tallying clean, smoke, cloudiness and microorganisms. It stipulates the era and specialized points of interest of respiratory protective equipment, and the texture, structure, appearance, execution, and filtration capability of clean covers ( Clean resistance rate), respiratory resistance, testing techniques, thing recognizable verification, bundling, etc. have strict requirements[10].	To compare the disinfected mask according to standards
---	--------------	--	--

### 1.3 Summary of the proposed project

Our design goal is to create a smart microorganism identification and filtration efficiency monitoring system that will assess a face mask's effectiveness both before and after a face mask particle filtration equipment has cleaned it. Since COVID-19, the use of masks has dramatically increased. The air in our environment has gotten incredibly dirty. Masks are now necessary for us to wear in our daily lives as a result. To ensure that our mask is successful, we must first see if it can suction the airborne weather particles. Testing the cover requires investigating novel approaches for gathering information and assessing its effectiveness with the aid of contemporary developments. Every feasible path has benefits and drawbacks. Out of all of them, we must choose the one that will give us the best returns with the fewest flaws. We chose three design methods for our project before settling on the IOT Based Particle Filtration System as the top choice. IOT's use has recently expanded a little since it can store data on cloud servers. Due to its expanding popularity and attractiveness, people are eager to utilize IOT to carry out any kind of checking handle.

### 1.4 Conclusion:

In conclusion , we want to say that as the rate of pollution, dust, viruses and bacterias increases, which are the main reasons behind the increasing sickness rates. People have to wear a quality mask to protect them from diseases. Sometimes the quality masks safety kits are so expensive that not everyone can afford them . So here, we come with a solution to fitaration the particles and can analyze the efficiency. After our test we are assuming that the masks or the safety kits will be able to be reused. Moreover, with the help of our test we will be able to store the efficiency test values and data in the cloud so that it will be easy to analyze and accessible. Furthermore, we will be able to test a large number of masks in a short time which will really aid institutions and industries. Lastly, from our test we will use our particle filtration efficiency test setup to hospitals and medical centers as the doctors, other staff and patients need to be disinfected more than others.

## Chapter 2[CO5, CO6]

### Project Design Approach

#### 2.1 Introduction:

The size of coronavirus is 50 nm to 140 nm in diameter. and the size of dust is almost 1-100 micrometer in diameter. An efficient mask can prevent airborne diseases which infect the human body through air and also can prevent the transmission of those diseases. Filtering effectiveness from the most penetration nanoparticles of 0.3 m varied from 83–99 percent for N95 and KN95 respiratory protection, 42–88 percent for surgical masks, 16–23 percent for fabric masks, and 9 percent for bandana mask on average. The outcome of research on the impact of utilizing twin surgical masks or placing a fabric mask across various surgical mask on filtering properties. When compared to the top of the separate mask results, the filtering performance can be increased by 25% in the majority of these combos for nanoparticles 0.3–1 m in diameter all with no significant change in the filtering parameter. That's why we need to implement a smart microorganism detection and filtration efficiency monitoring system which will measure/identify the efficiency of a face mask before and after disinfecting it by a face mask particle filtration device.

#### 2.2 Identify multiple design approach:

After some research and analysis ,we have chosen 3 design approaches.

1. Particle Filtration System Using IR Sensor
2. Particle filtration system with Air Quality Indicator sensor
3. IOT Based Particle Filtration System

#### 2.3 Describe multiple design approach:

##### 1. Particle Filtration System Using IR Sensor

The infrared sensor is a chamber with an air current going through it. On one side of the chamber, there's an infrared emitter( like a light bulb), and on the other side, there's an infrared detector. Each flyspeck in the air blocks a little bit of light, meaning that a little bit lower of it'll reach the detector. In other words, the light gets dimmer. Grounded on how bright the light is, an estimate can be made as to how numerous patches are in the air. but the detector can't tell what's causing the light to shroud. It could be 60 PM2.5  $\mu\text{m}$  patches, 15 PM10 $\mu\text{m}$  patches or 1 grain of rice[12]. Figure1 depicts the process flow for particle filtration utilizing infrared technology.



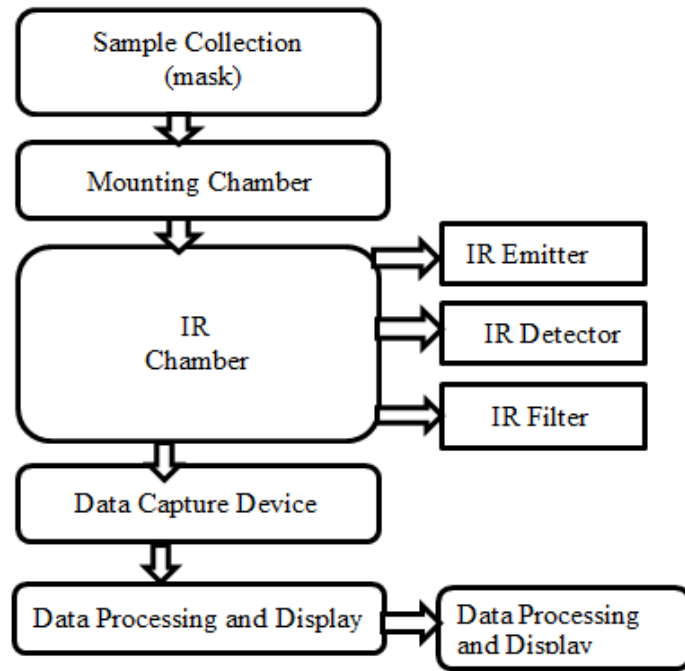


Fig: 1 Particle Filtration Using IR

## 2. Particle filtration system with Air Quality Indicator sensor

In this case the number of patches is counted by the flyspeck counter detector. Mask will be entered on the mask mount chamber and all the direction results will be shown on the assemble display with the system. Data will be shown on the display one by one for each mask. Figure2 depicts the flow of a particle filter system with an air quality indicator sensor.

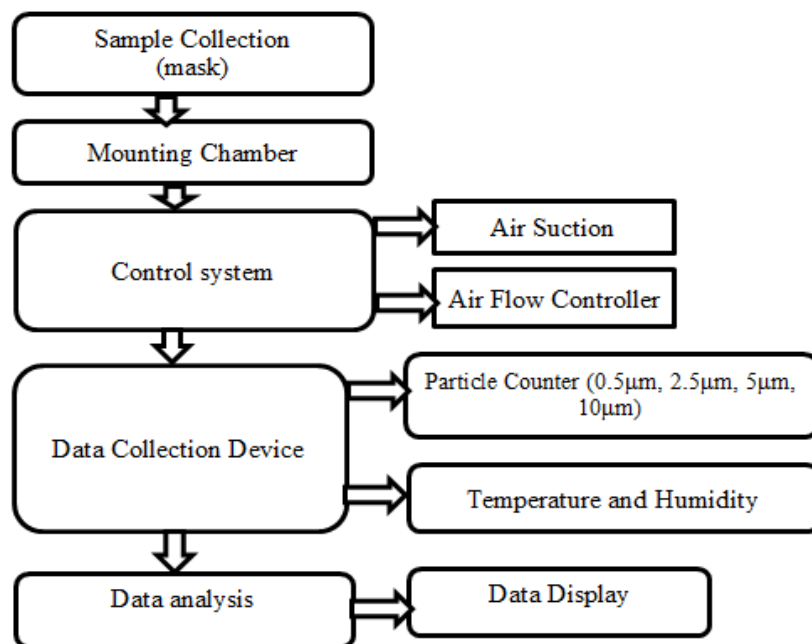


Fig2: Particle filtration with particle counter sensors

For that process a homemade counting system will be demanded to check the mask contagion or patch chance which will be shown in the display. If the clean chance of the mask is low also for that mask the process will be started from the mask mounting chamber. But in that process a display of chance will be shown for a couple of seconds which will be pivotal for the discovery process to make a trace for every mask on the chamber[11].

### 3. IOT Based Particle Filtration System

Apart from all the approaches , the best option is IOT based particle filtration as in this approach sensors will be controlled via WiFi capable IoT (Internet of Things) controller which is used for data transfer via serial communication. In Figure3, we have a flow diagram for an IOT-based particle filtering system. Comparing cloud data sets to another is currently a popular monitoring survey approach for analyzing particle filtration efficiency of masks. Using the AQI sensor to obtain data sets allows us a comprehensive output, to clearly measure, analyze, and show any change between surveys over time[11].

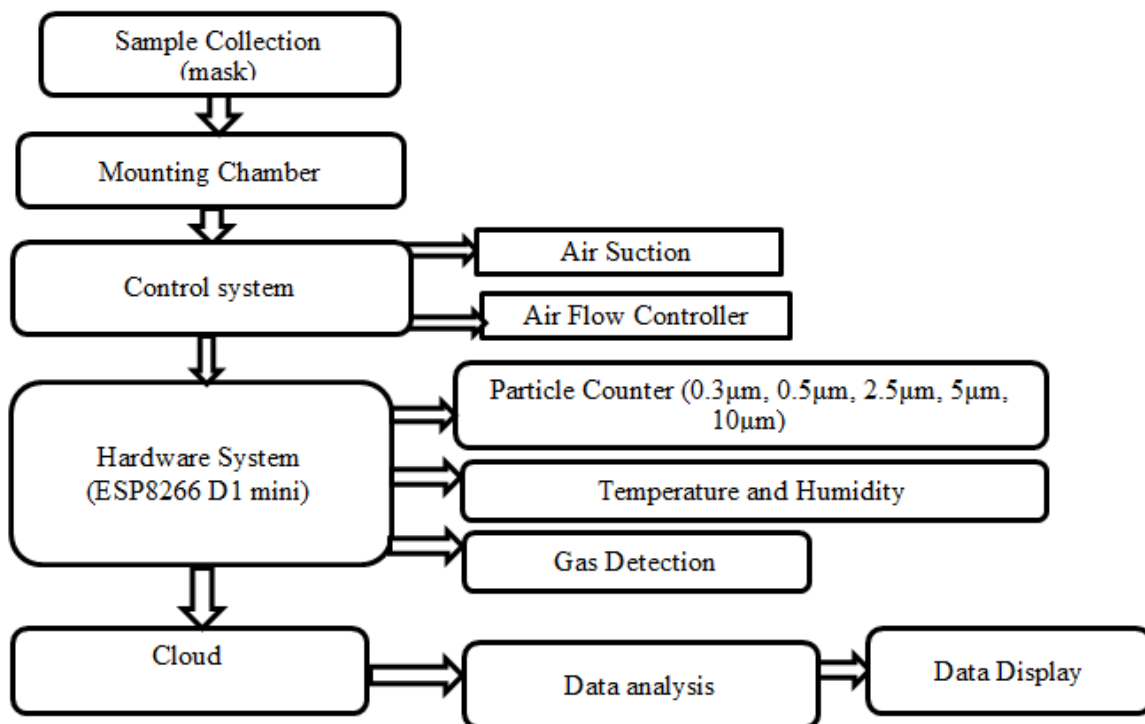


Fig3: IOT Based Particle Filtration

## 2.4 Analysis of multiple design approach

Table 4: Analysis of multiple design approach

Features	Design 1	Design 2	Design 3
	Particle Filtration Using IR	Particle filtration with particle counter sensors	IOT Based Particle Filtration
Particle Size	2.5µm and 10µm	0.5µm, 2.5µm, 1µm, 2.5µm, 5µm, 10µm	0.3µm, 0.5µm, 2.5µm, 1µm, 2.5µm, 5µm, 10µm
Data Store	No	No	Yes
Accuracy	Less Accuracy	Precise Accuracy	Precise Accuracy
Problematic Characteristic	less accuracy for >2.5µm particle	less accuracy for >0.5µm particle	less accuracy for >0.3 particle
Communication Ability	No communication	No communication	4G communication
Technical Complexity	High	High	Very High
Cost Efficiency	Lowest	Lower	Higher

Table 4 contains a representation of our analysis of several design philosophies. Our first method can detect particles that are 2.5 µm and 10µm in size, while our second method can detect particles that are 0.5µm , 2.5 µm, 1 µm, 2.5µm , 5µm , and 10 µm in size. Data storage is only available with our third technique. Our second and third approaches are more accurate than our first one in precise terms. Communication skills are our third strategy, which is also reasonably priced.

## 2.5 Conclusion

Out of all the options, IOT-based particle filtering stands out as the best choice since it uses a WiFi-capable IoT (Internet of Things) controller to control the sensors and uses serial connection for data transfer. IOT, whose use has recently increased somewhat, can also store data on cloud servers. Due to its expanding popularity and attractiveness, people are eager to utilize IOT to carry out any kind of checking handle.

## Chapter 3 [CO9]

### Use of Modern Engineering and IT Tool

#### 3.1 Introduction

Innovation may be a portion of cutting edge engineering—but it is additionally centered on the headway and comprehension of innovative frameworks, their items, impacts, and suitability. Additionally, non-technological strategies are a concern. We have utilized different cutting edge engineering apparatuses for this venture. Usually fulfilled by beginning with making an effort to memorize how the instrument is utilized, utilizing it to comprehend topics in suitable courses, and after that applying it to— develop, plan, actualize, and illustrate a person's work. This has permitted us to urge proper information, and comes about for the examination of the information collected. We have legitimately explained each of the instruments to this extent.

#### 3.2 Select appropriate engineering and IT tools

We have two requirements to meet while choosing contemporary engineering tools. One is software, the other is hardware. When it came to choosing software tools, we initially tried to use the IOT cloud but it was getting considerably slower while displaying data and it took a long time to calibrate our sensors. We finally switched over to Blynk. In terms of hardware, we intended to utilize an ESP32, but when it was operating, it began to burn. Once more, we purchased another one to test it, but we kept running into the same issue, so we chose to utilize an ESP 8266 D1. So we finally selected our Hardware and software tools.

##### I. Hardware tools:

1. PMS7003
2. DHT22 digital temperature humidity sensor.
3. MQ-131 Sensor CO Ozone Gas Sensor Module Detector Gas Detection Module
4. Vacuum Pump
5. Wi-Fi microchip ESP8266 D1 Mini

##### II. Software tools:

1. Tinkercad
2. Blynk
3. Thingspeak

##### III. Simulation tools:

Proteus 8 Professional

### 3.3 Use of modern engineering and IT tools

#### Hardware:

**Temperature and Humidity sensor DHT22:** The DHT22 may be a low-cost advanced temperature and humidity sensor with a single wire computerized interface. It employs a capacitive humidity sensor and a thermistor to measure the encompassing air and spits out a computerized flag on the information stick. To monitor the temperature and humidity DHT22 is an important tool for us.

**Vacuum Pump:** The forerunner to the vacuum pump was the suction pump. A vacuum pump could be a gadget that draws gas atoms from a fixed volume in order to take off behind a fractional vacuum. The work of a vacuum pump is to produce a relative vacuum inside a capacity. This vacuum pump will suck the air in a certain pressure through the mask and that air will go through our pms sensor.

**MQ-131 Sensor CO Ozone Gas Sensor Module Detector Gas Detection Module:** Delicate fabric of the MQ131 gas sensor is  $O_3$  SnO<sub>2</sub>, which has lower conductivity in clean air when Ozone gas exists. The sensor's conductivity is higher alongside the gas concentration rising. MQ131 gas sensor includes a high affectability to Ozone, moreover delicate to  $O_3$  CL<sub>2</sub>, NO<sub>2</sub>, etc.

**PMS7003 Particle Counter:** PMS particle counter sensor used to obtain the number of suspended particles in the air, i.e. the concentration of particles, and output them in the form of a digital interface. Dust sensor permits you to screen the immaculateness of the air, measuring the PM1.0, PM2.5, PM10. Prepared with a sensor empowering location of particles with breadth over 0.3  $\mu\text{m}$ , e.g. cigarette smoke. The chip is fueled by a voltage of 5, whereas the interface works with a voltage of 3.3 V, and communicates through the UART interface.

**Wi-Fi microchip ESP8266 D1 mini:** Only one 3.3V output pin and one ground pin are available on the ESP8266 WeMos D1 Mini to power an external device. Custom PCBs are now simple to make and reasonably priced. More than one 3.3V pin and one ground for the PCB are not required if your project is ready to go with the WeMos D1 Mini on it. To power various electronic components, you can connect the project's 3.3V and ground pins to the rails of the breadboard. When the ESP8266 WeMos D1 Mini is supplied by USB, the 5V pin can be used as a 4.67V output or as a power supply for the ESP8266 with voltages between 4V and 6V. Therefore, since these components need to function with a supply voltage of 4.67V, you might additionally supply electronic components that require a supply voltage of 5V.

**Arduino Nano:** The Arduino Nano and Arduino UNO are quite similar. They can both share the same program because they both utilize the same processor (Atmega328p). The size of

each is one significant distinction. Because UNO is twice as big as Nano, it takes up more room on your project. Nano is also compatible with breadboards, although Uno is not. A regular USB cable is required to program an Uno, whereas a micro USB cable is required to program a Nano. The tiny USB jack will draw the electricity needed for the board to operate when it is connected through a wire to a phone charger or computer. To power the board, an unregulated 6–12V can be given to the Vin pin. It is controlled to +5V by the on-board voltage regulator. If you have a regulated +5V supply, you can connect it straight to the Arduino's +5V pin.

### **Software:**

**Tinkercad:** Tinkercad is an internet connection of program devices from Autodesk that empower total fledglings to form 3D models. This CAD program is based on helpful strong geometry (CSG), which permits clients to form complex models by combining less difficult objects together. As a result, this 3D modeling program is user-friendly and as of now enjoyed by numerous, particularly teachers, kids, hobbyists, and architects. Best of all, it's free and you simply require a web association to reply to it. The program permits clients to form models that are congruous with 3D printing, an incredible choice for tenderfoots to the technology. We are designing our 3D model by using this tool as it is more convenient for the beginners to design any 3D model.[14]

**Blynk framework:** Blynk is an IoT stage for iOS or Android smartphones that's utilized to control Arduino, Raspberry Pi and NodeMCU by means of the Web. This application is utilized to form a graphical interface or human machine interface (HMI) by compiling and giving the suitable address on the accessible widgets. Blynk was planned for the Web of Things. It can control equipment remotely, it can show sensor information, it can store information, visualize it and do numerous other cool things.[15]

**Thingspeak:** ThingSpeak is an IoT Cloud stage where you'll send sensor information to the cloud. You'll moreover analyze and visualize your information with MATLAB or other computer programs, counting making your claim applications. The ThingSpeak benefit is worked by MathWorks. In order to sign up for ThingSpeak, you must make an unused MathWorks Account or log in to your existing MathWorks Account. ThingSpeak is free for little non-commercial projects. ThingSpeak incorporates a Web Service (REST API) that lets you collect and store sensor information within the cloud and create Web of Things applications. It works with Arduino, Raspberry Pi and MATLAB (premade libraries and APIs exist) But it ought to work with all kinds of Programming Dialects, since it employs a REST API and HTTP.[13]

### **Circuit simulation:**

**Proteus 8 Professional:** Proteus is a complete development platform from product concept to design completion. Its advantages are intelligent principle layout, hybrid circuit simulation

and accurate analysis, single-chip software debugging, single-chip and peripheral circuit co-simulation, PCB automatic layout and wiring[16]. We have used this proteus software so that we can build our software designs and compare the simulation results. Proteus supports several common single-chip models and generic peripheral models. Its dynamic simulation is based on frames and animation; thus, the visual effects are excellent which fulfills our requirements[17]. Also, we can use various sensors through this simulation software which make our simulation function easier.

### Appropriate tools and solution for final prototype:

#### Circuit design

We must launch a new project in Proteus and create our various design methods there in order to support diverse design approaches. The selection of the circuit's component parts comes next. We produce the code in the Arduino IDE and synthesize it in proteus to build our planned circuit. After the circuit was put together and tested, it was easy to keep track of our target value. In Figure4, we have a proteus flow diagram.

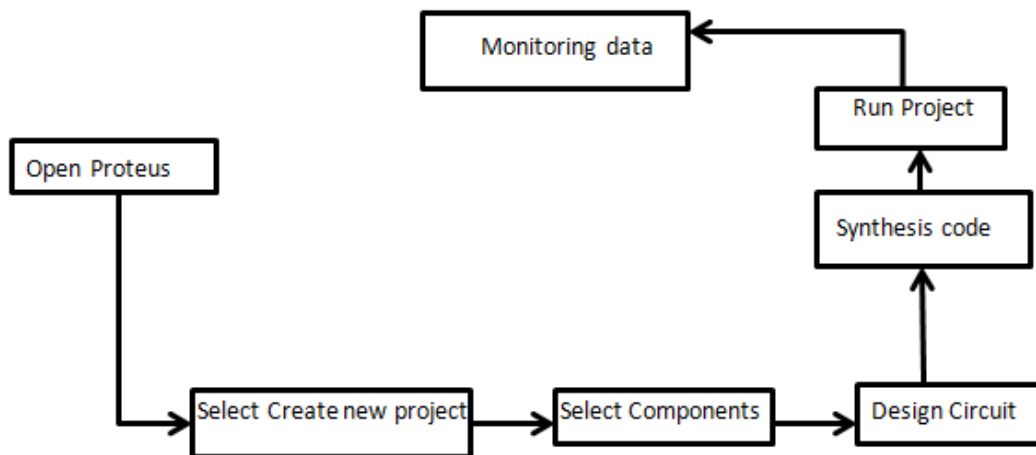
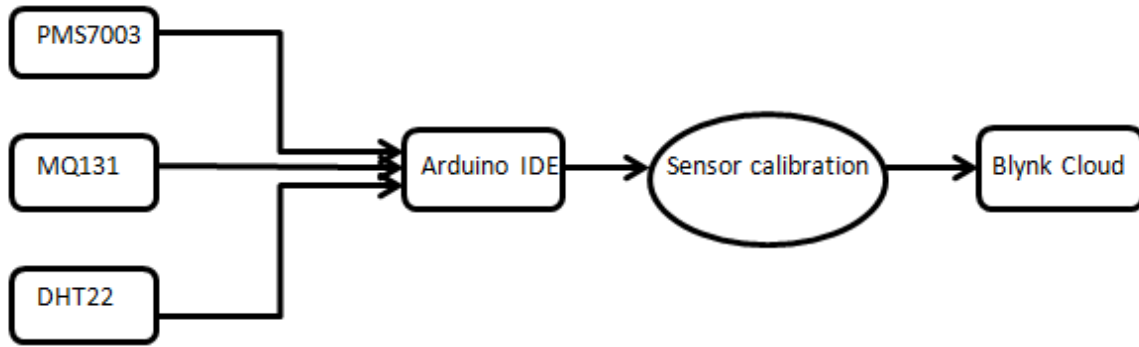


Figure4: Work flow diagram of proteus

Proteus didn't include all of the sensors, therefore libraries from github or Google had to be downloaded and added. In addition, before synchronizing the circuits, we had to fix the coding issues. Additionally, our code won't compile without the library for the Arduino IDE.

#### Hardware Prototype

In Figure5, we've displayed a workflow for the final prototype's chosen tools. We had to calibrate and sync our sensors for our final prototype. In the Arduino IDE, we had to download libraries for the ESP8266, Arduino, DHT, PMS7003, and MQ131. Then, we had to calibrate our sensors so they could collect data, and we used a cloud server for display. When everything was finished, we could access our data in the Blynk cloud.



**Figure5:Workflow of selected tools for final prototype**

### **3.4 Conclusion**

For this extent, we utilized a wide range of cutting edge building innovations. As a result, we were able to analyze the data collected and deliver exact results. Each of the instruments used in this venture has been completely clarified. Utilizing these various instruments has made a difference in us better comprehending advanced advances, counting equipment improvement and programming.



## Chapter 4[CO5, CO6,CO7]

### Optimization of Multiple Design and Finding the Optimal Solution

#### 4.1 Introduction

The use of masks has significantly grown since COVID-19. Our environment's air has become extremely filthy. Therefore, it has become vital for us to wear masks in our daily lives. However, we must determine whether our mask can suction the airborne weather particles in order to ensure its effectiveness. Testing the cover entails looking into creative ways to obtain data and evaluate its efficacy with the use of modern advancements. Every achievable path includes advantages and obstacles. We must pick the one that will provide us the highest returns with the fewest defects out of all of them. To get at our ultimate approach, we chose three design approaches for our project and identified the IOT Based Particle Filtration System as the best option. Because IOT has the ability to store data on cloud servers, its use has recently increased somewhat. People are willing to use IOT to conduct any type of checking handle due to its growing demand and points of interest.

#### 4.2 Optimization of multiple design approach

##### Design 1

##### Particle Filtration system Using IR Sensor:

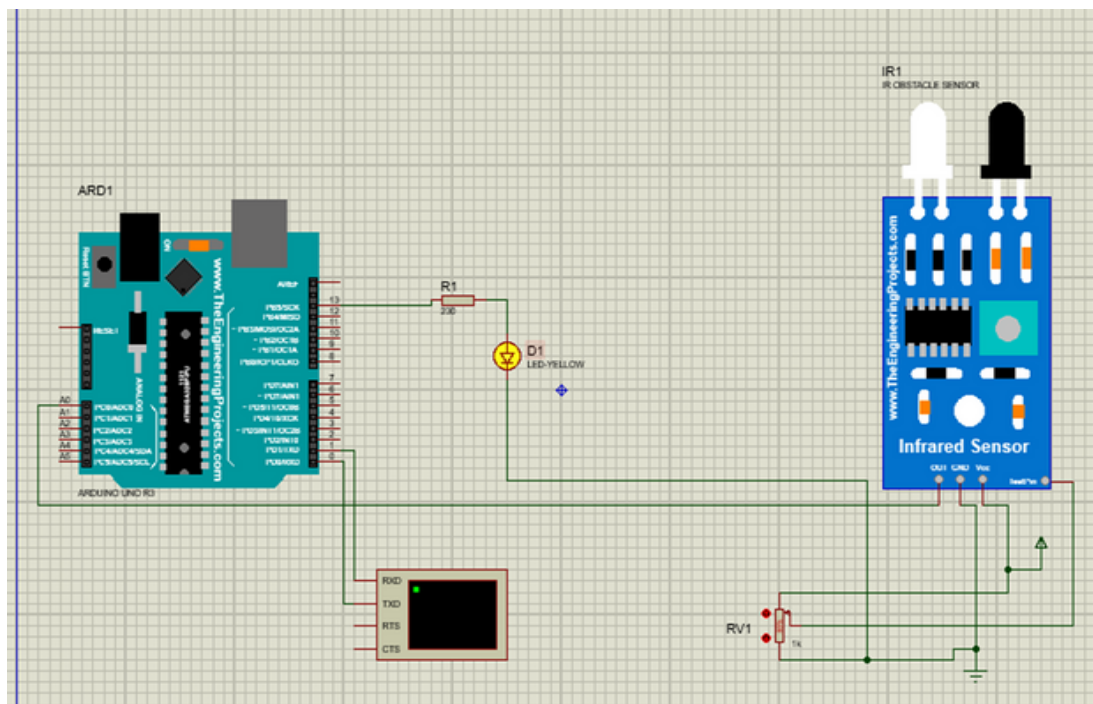
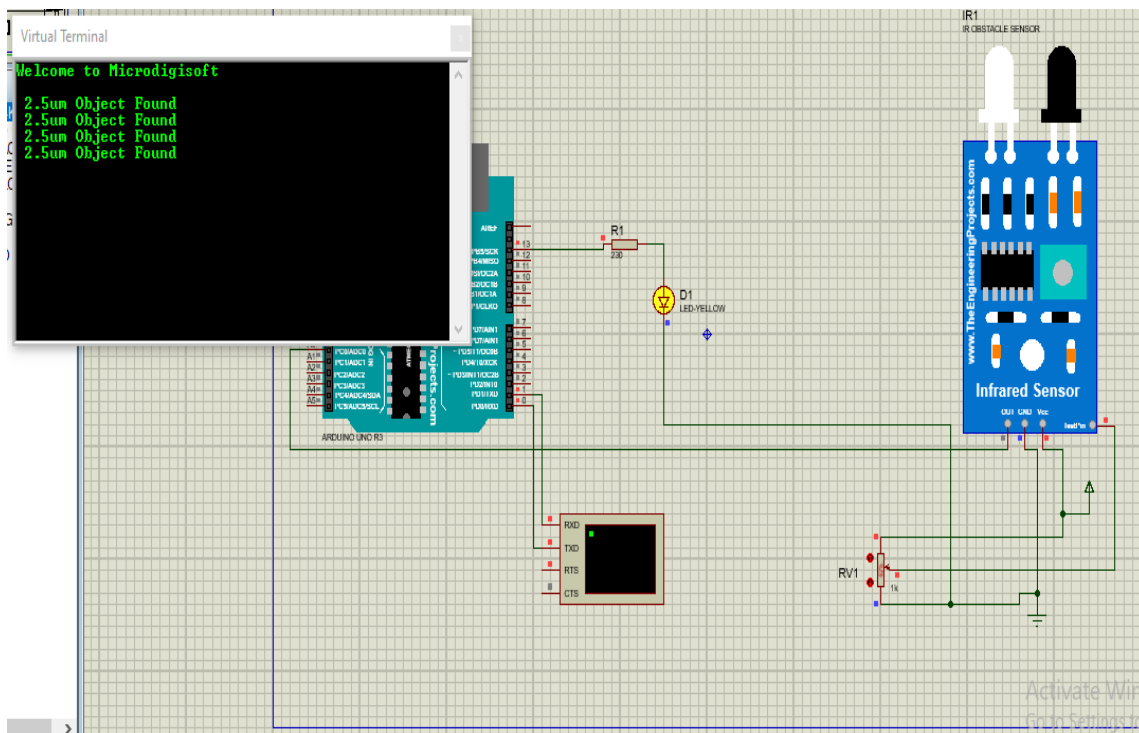


Figure6:Simulation model of Particle Filtration Using IR

Figure6 depicts a simulation model for particle filtering using infrared technology. Proteus software was used to create and simulate our concept. Although our hardware has different capability than the default sensor, we have utilized a default IR sensor here to represent our actual IR sensor because Proteus does not contain any more IR sensors. A default sensor has been employed to test the IR model for this purpose. Additionally, an LED light is being used to symbolize an electric bim. The IR sensor will therefore detect the particle as soon as the simulation begins, and the LED light will begin to beep. We will receive the particle size value from the sensor. To maintain hardware compatibility, we conducted the simulation in this manner.



**Figure7:Simulation result of Particle Filtration Using IR**

We may therefore deduce from the outcome that we are receiving the particle size that has been picked up by the terminal's sensor. In Figure 7 we can see in the result that the IR sensor is detecting 2.5µm sized particles since, as we know, IR sensors can detect particles as small as 2.5µm to as large as 10 µm.

**Table5: Basis of analysis for IR**

Target variable	Used sensor	Remark
Particle size	IR sensor	2.5µm,5µm,10µm sized particles detected only.

## Design2:

### Particle filtration system with Air Quality Indicator sensor:

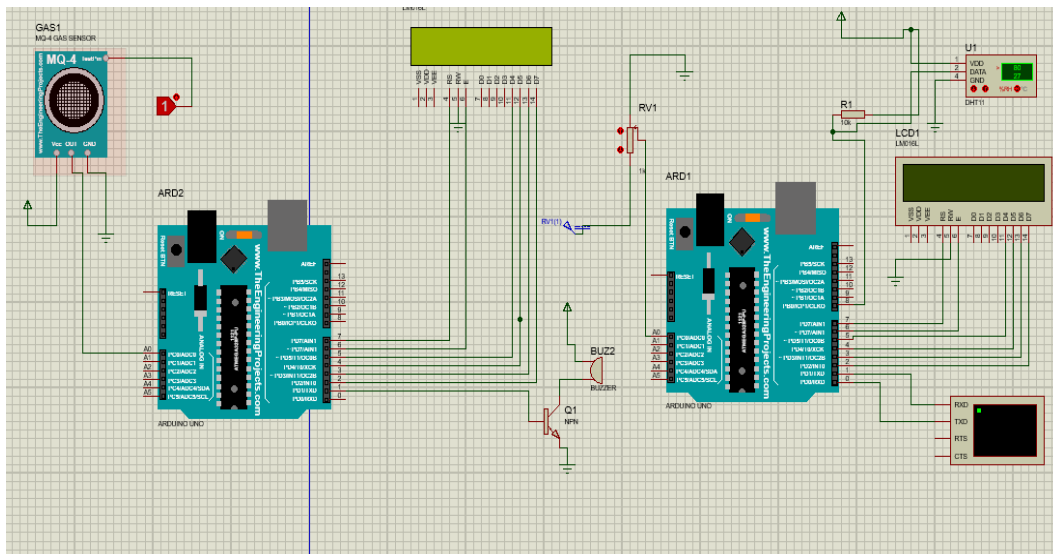


Figure8: Simulation model of Particle filtration with Air Quality Indicator sensor

Proteus has also been utilized for design 2. In Figure8, we have a depiction of a simulation model for particle filtering with an Air Quality Indicator sensor. Here, a DHT11 sensor has been used with an Arduino Uno to detect temperature and pressure. Additionally, we are using a variable resistance to represent our particle counter sensor (since it is not included in proteus or any other software) with a second Arduino Uno, as well as a MQ-4 gas sensor to detect smoke, alcohol, and other gasses, as well as a buzzer.

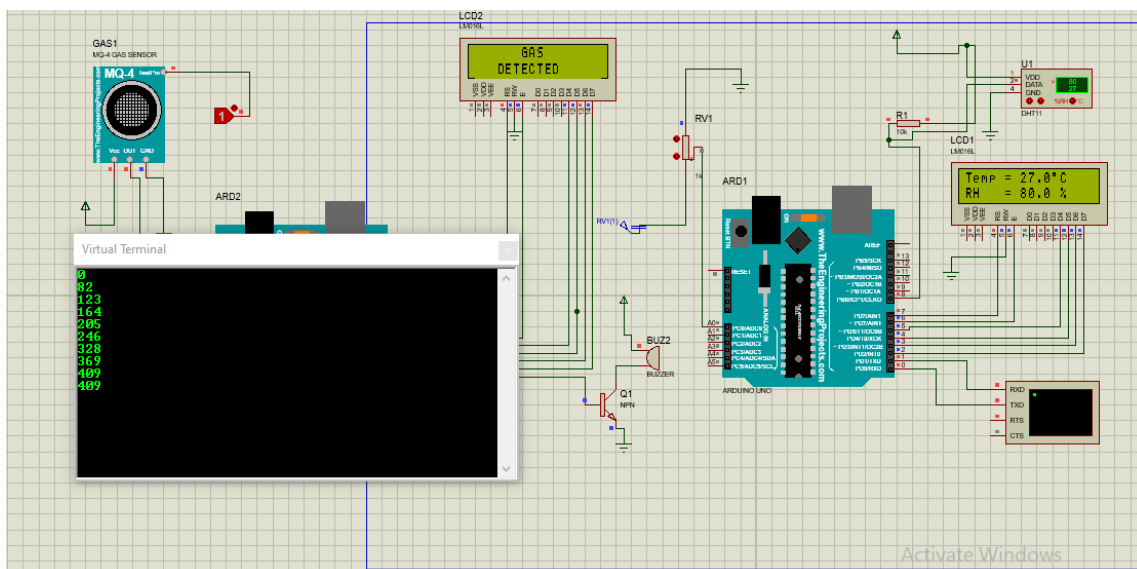


Figure9: Simulation result of Particle filtration with Air Quality Indicator sensor

During executing a simulation, the LCD display shows the temperature and pressure values. When ozone gas is identified, the buzzer begins to beep, and we can see gas detected printed

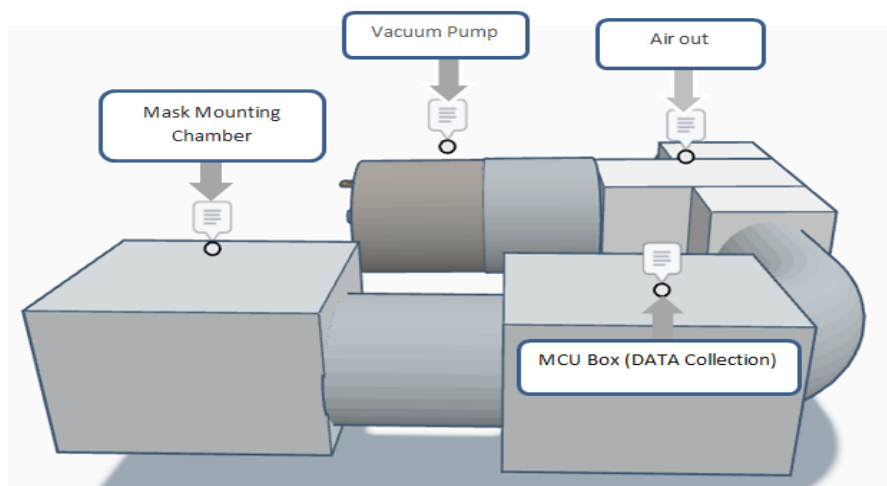
in the LCD display. In Figure9 we noticed that as the variable resistance value climbed from minimum to maximum, the particle suction range did as well. Though the primary function of the particle counter sensor is to count particles while also measuring their size, proteus did not have access to this sensor, hence it was not feasible to display the size of the particles sucked by the device. Essentially a manual system, this one.

**Table6:Basis of analysis for AQI system**

Target variable	Used sensor	Remark
Particle size	PMS5003	This system gives the value of the size of the particle. Here in this system 0.5µm, 2.5µm, 5µm, 10µm sized particle can be detected
Ozone gas	MQ-131	This system's advantages include its capacity to assess CO <sub>2</sub> , CO and O <sub>3</sub> concentrations in the discuss, recognize when they are too high and give pollution reduction arrangements as required.
Temperature and humidity	DHT22	This system shows how a DHT22 Computerized Temperature Humidity Sensor can accurately estimate temperature and humidity.

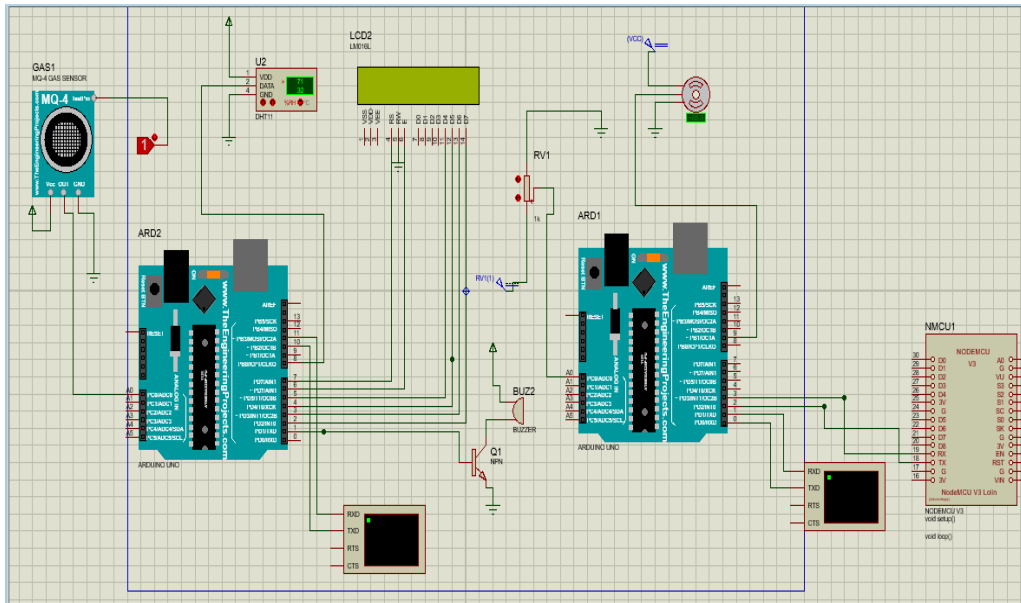
### Design 3:

#### IOT Based Particle Filtration System:



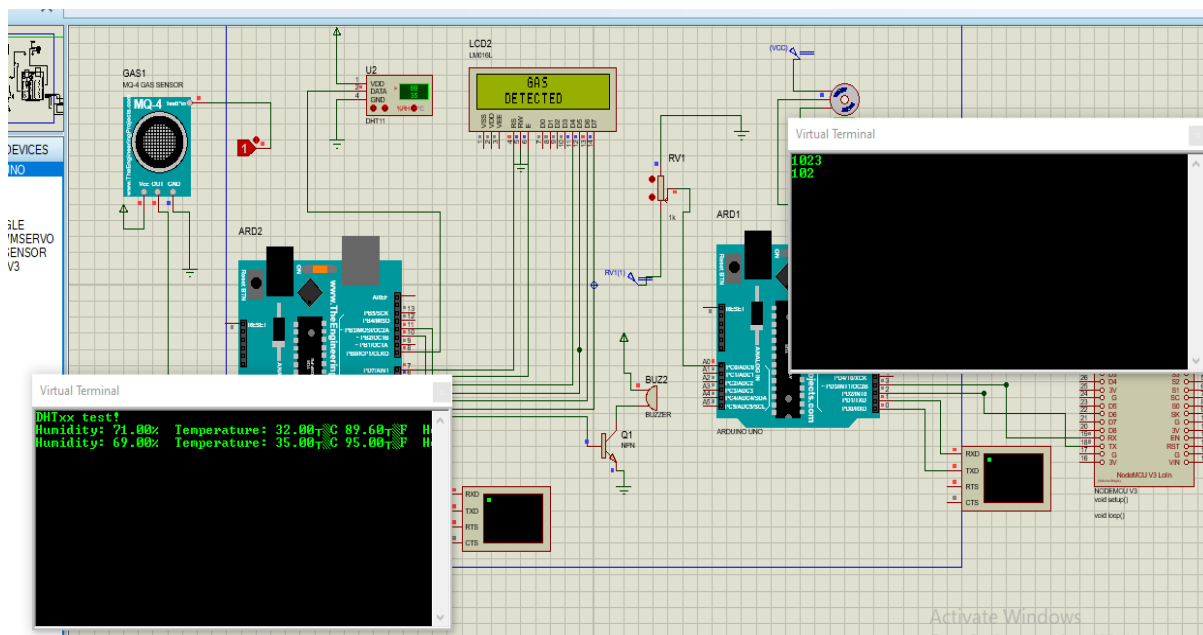
**Figure10:3D model of IOT Based Particle Filtration**

Since Tinkercad makes it simple for beginners to understand how to use the software and generate 3D models, we utilized it to produce this 3D model. To show how our subsystems will be connected, we made this 3D model.



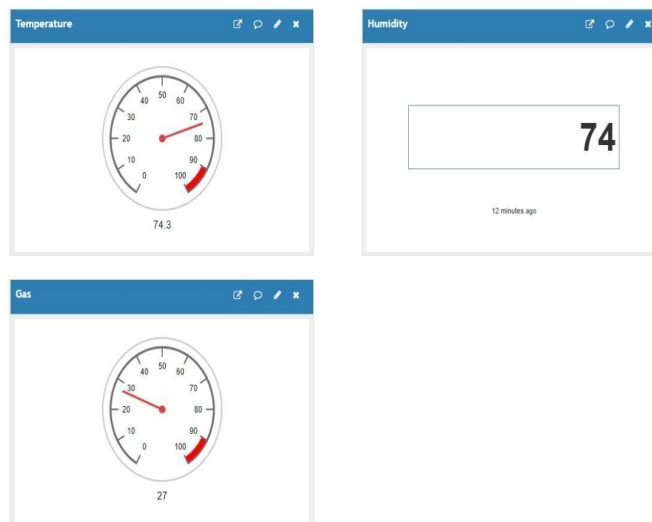
**Figure11:Simulation model of IOT Based Particle Filtration**

We further used proteus for design 3. In Figure11, a simulation model of IOT-based particle filtration is depicted. Because proteus or any other program does not support it, a variable resistance was utilized to represent a particle counter sensor together with another Arduino Uno and a servo motor to imitate a vacuum pump (because we wanted to control this system by controlling the pressure). An Arduino Uno is attached to a buzzer, which measures temperature and pressure. A MQ-4 gas sensor measures ozone gas. Additionally, because the NODEMCU can save data to a cloud server, we developed it to replace our ESP8266 D1 mini. Finding the tiniest particle is our objective here, and we want to save the information for later use.

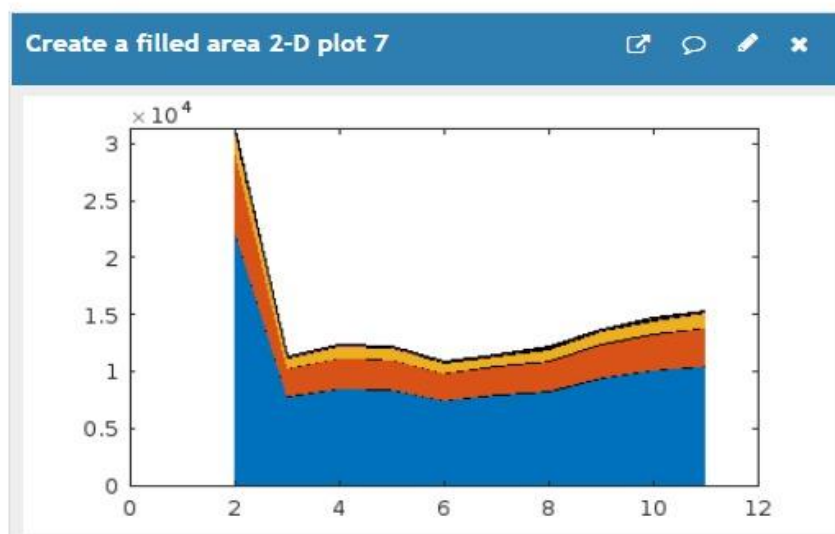


**Figure12:Simulation result of IOT Based Particle Filtration**

As soon as the simulation began, like Figure12 we could see the temperature and pressure values in the terminal, and when ozone gas was identified, the buzzer began to beep and the LCD display displayed "gas detected." Now, when the motor began to turn and the variable resistance was at its lowest, it would give a defined minimum range of particles that the system would suction until we kept it at its highest. Additionally, the particle suction range would expand to its maximum when the value has reached its highest. Although the particle counter sensor's primary function is to measure particle size and count them, the proteus lacks this sensor, making it impossible to determine how many particles were sucked through the device. Just like our hardware prototype, we were able to change the range of the particle sucked through the device by adjusting the servo motor.



**Figure13:Temperature and humidity result in Thingspeak**



**Figure 14:2-D plot of particles**



**Figure15:Graph for Temperature, humidity, Particles monitoring**

Due to the IOT cloud server's ability to store data in the cloud, we could also view the value of temperature and pressure there. We have displayed our data in thingspeak like Figure13,14,15. Particles are plotted in two dimensions. Additionally, we may observe particle graphs in various sizes, including 0.3μm,0.5μm,2.5μm,5μm,10μm



**Table7:Basis of analysis For IOT based system**

Target variable	Used sensor	Remark
Particle size	PMS5003	This system gives the value of the size of the particle. Here in this system 0.3µm, 0.5µm, 2.5µm, 5µm, 10µm sized particle can be detected
Ozone gas	MQ-131	This system's advantages include its capacity to assess CO <sub>2</sub> , CO and O <sub>3</sub> concentrations in the discuss, recognize when they are too high and give pollution reduction arrangements as required.
Temperature and humidity	DHT22	This system shows how a DHT22 Computerized Temperature Humidity Sensor can accurately estimate temperature and humidity.
Data store	ESP D1 mini	This system can store the data and can visualize the stored data in IOT cloud

### 4.3 Identify optimal design approach

Our optimal design approach is IOT based microorganism detection and filtration.

#### Operational Principle of PMS7003

The PMS7003 is a type of digital, all-purpose particle concentration sensor that may be used to measure the concentration of particles in the air as well as the number of suspended particles in the air. To deliver accurate concentration data on time, this sensor can be integrated into a variety of devices that measure the amount of suspended particles in the air or other environmental improvement equipment. For such a sensor, the laser scattering concept is applied, which involves producing scattering by using a laser to radiate suspended particles in the air, collecting the scattered light to a specific extent, and then obtaining the curve of the changed scattering light over time. In the end, the MIE theory may be used to determine the equivalent particle diameter and the number of particles of varied diameters per unit volume using a microprocessor. It has a measuring range 0.3, 0.5, 1.0, 2.5, 5, 10 micrometers. Efficiency of Counting 50% @ 0.3 m 98% @ >= 0.5 m. Effective Range (standard PM2.5) 0~500 µg/m<sup>3</sup>. [18]

#### Operational Principle of MQ131

The MQ131 gas sensor's sensitive component is SnO<sub>2</sub>, which has a reduced conductivity in clean air, when ozone gas is present. As the gas concentration rises, the conductivity of the sensor also increases. Please utilize a straightforward electro circuit to translate changes in conductivity into a signal that corresponds to gas concentration. Ozone is a gas that the MQ131 gas sensor is highly sensitive to, along with CL<sub>2</sub>, NO<sub>2</sub>, and other gasses. Ozone concentration is 10–1000 ppm. The loop voltage is 24 V DC (Vc). 5.0V 0.2V AC or DC



Circuit Heater Voltage Load Resistance (Room Team) The adjustable heater resistance is 313. Humidity  $20^{\circ}\text{C} \pm 2^{\circ}\text{C}$ ;  $65\% \pm 5\% \text{RH}$ . Test method circuit condition  $V_c: 5.0 \text{ V}$   $0.1 \text{ V}$ ;  $V_H: 5.0 \text{ V}$   $0.1 \text{ V}$ . [19]

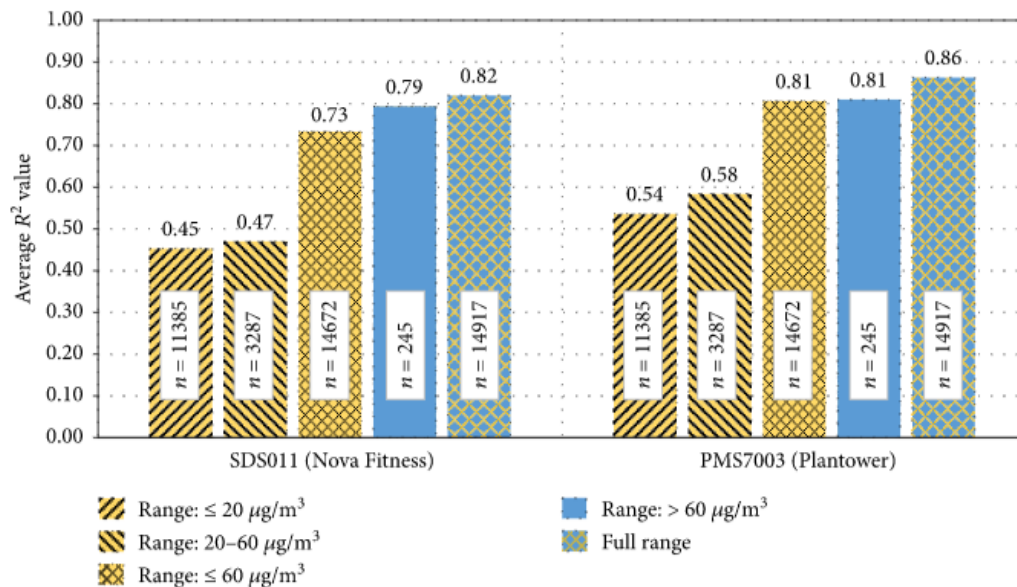
### **Importance of IOT**

IoT, or the "Internet of Things," is a rapidly developing technical area that makes any electrical gadget smarter. To boost production and improve efficiency, many businesses are starting to implement this technology into their operations. In addition to connecting the device to the internet, this cutting-edge technology offers the user a number of capabilities including real-time analytics, a platform to study the data that has been collected, cloud data storage, the ability to initiate an action from a distance, remote notifications, etc. This technology can be incorporated into practically every industry due to its broad variety of uses. Maintaining the effectiveness and security of the system becomes increasingly crucial as more devices connect to the Internet of Things. Traditional approaches for process improvement services, however, are no longer adequate. Many devices, especially those undertaking implementation, require early testing [20].

### **Statistics Overview of different particle counter sensors**

At the moment, specific commercial sensors make it possible to do inexpensive defilement checks, and the use of these devices is growing in popularity around the world. There are several different types of sensors available for estimating particulate matter. The hallmark of all commercial PM sensors is their basic mode of operation, which involves measuring the amount of light dispersed by particles that are transported in a discrete stream via a light column. Despite the fact that particles can change in size, chemical makeup, shape, or surface area, the harmful effects of PM are often correlated with particle counts. The ability of particles with smaller streamlined dimensions to enter the lower respiratory system is more pronounced. Another benefit of optical PM sensors is their low power consumption; they typically operate with working currents of less than 250 mA and a control supply voltage of 5 V. Additionally, they are typically small and light, and the yield data can be obtained often. The earlier Plantower sensor models (PMS1003, PMS3003, and PMS5003) were considered to be effective tools for PM<sub>2.5</sub>. High relative humidity, however, had an impact on the sensor yields, as seen in observation number 5. High air humidity conditions can have several effects on how optical PM sensors operate. The main cluster of problems is caused by the electronic circuits failing in an extremely moist atmosphere. One-sided estimation or damage to sensors could result from this. Currently, a number of challenges are connected to molecular characteristics and how light-scattering devices work. The linearity of sensor responses is the subject of the other calibration perspective. In particular, PMS7003 sensors reach R<sup>2</sup> values of greater than 0.8 for short-term average times and greater than 0.9 for daily midpoints. In general, PM<sub>2.5</sub> relative errors were found to be the largest. The error values were up to a few hundred percent for 5 concentrations below 20–30 g/m<sup>3</sup>. The majority of the mistakes fell between 90% and 100% between 20 g/m<sup>3</sup> and 60 g/m<sup>3</sup> (OPC-N2 only exhibited errors up to 170%). The relative errors for SDS011 (12% on average) and PMS7003 (11% on average) were between 0% and 31% over the level of 60 g/m<sup>3</sup>. For the Winsen ZH03A stable unit,

some larger errors (3%–41%; 25% on average) were noted. Relative errors for the OPC-N2 counter ranged from 13% to 58% (37% on average).[21]



**Figure16: Averaged coefficients of determination (R<sup>2</sup>) for SDS011 and PMS7003 sensors in different concentration ranges for 15 min. n in the text box inside the bar indicates the number of samples used for fitting. Source: Adapted from [21]**

The ability to increase the temporal and spatial resolution of particulate matter data is provided by low-cost sensors. However, before taking any monitoring action, such sensors should be calibrated in settings similar to the final ones. The findings of a collocated comparison of four low-cost optical sensor variants with a TEOM 1400a analyzer are presented in the paper. The sensors utilized in this study were SDS011 (Nova Fitness), ZH03A (Winsen), PMS7003 (Plantower), and OPC-N2 (Alphasense).[20] To assess the sensor performance under the same measurement settings, three identical examples of each sensor model were put in a single box. In Wroclaw, monitoring of the PM<sub>2.5</sub> percentage was done for over six months, from August 21, 2017, to February 19, 2018. (Poland). The coefficient of variation was used to examine the reproducibility of sensor units (CV). CV values for SDS011 and PMS7003 sensors were less than 7%, however they were equal to 20% for OPC-N2 devices. ZH03A's CV was greater than 50%, primarily because of errors.[20] During the measurements, the trends of the sensor outputs generally matched those of the TEOM data, but the sensor raw data showed a considerable overestimation of PM<sub>2.5</sub> concentrations. For 1 min, 15 min, and 1-hour averaged data for PMS7003 sensors (R<sup>2</sup>=0.83-0.89), SDS011 units (R<sup>2</sup>=0.79-0.86), and one unit of ZH03A (R<sup>2</sup>=0.74-0.81), a strong linear association between TEOM and sensors was seen. R<sup>2</sup> values for daily averages ranged from 0.87 to 0.90 for SDS011, 0.89 for ZH03A, and 0.91 to 0.93 for PMS7003. Only a weak linear connection (R<sup>2</sup>=0.43-0.61 for shorter time averages and 0.53-0.69 for daily data) existed between OPC-N2 and TEOM. For concentration ranges below 20-30 g/m<sup>3</sup>, there was significant data dispersion and considerable relative errors of PM<sub>2.5</sub> estimation.

SDS011 and OPC-N2 devices showed the effects of high relative humidity levels; above 80% RH, outputs were clearly overestimated.[21]

#### 4.4 Performance evaluation of developed solution

Based on our literature review and simulation ,we have got some features to compare between the designs like Table8 to get our optimal solution.

**Table8:Performance evaluation of multiple design approaches**

Features	Design 1	Design 2	Design 3
	Particle Filtration Using IR	Particle filtration with particle counter sensors	IOT Based Particle Filtration
Particle size	2.5µm and 10µm	0.5µm,2.5µm,5µm,10µm	0.3µm,0.5µm,2.5µm,5µm, 10µm
Temperature and humidity monitor	No	Yes	Yes
Air pressure control	No	No	Yes
Ozone gas detection	No	Yes	Yes
Data storing capability	No	No	Automated
Remote cloud server	No	No	Blynk cloud
Particle suction	Not Controlled	Not controlled	Controlled using pump
Design complexity	Medium	High	High

From the literature review ,we got the particle size and from the simulation we got other features like temperature and humidity monitor,air pressure control ,ozone gas detection,data storing capacity which is similar to our hardware prototype.We formulated a few rating criteria to assist us select the leading arrangement from the different design solutions.The criterias are-design complexity,microorganism detection,particle suction ,gas detection,air pressure control,temperature and humidity ,cost efficient , cloud server.

Since we have Five objectives, which are:

1. Microorganism detection
2. Ozone gas detection
3. Temperature and humidity
4. Remote cloud server
5. Cost efficient

We designed weightage matrix according to their priority which is shown in Table9

**Table9:Weighted Decision Matrix**

Designs	Design complexity	Micro Organism Detection	Particle suction	Gas Detection	Air Pressure Control	Temperature and humidity	Cost Efficient	Cloud Server	Total Rating
	Out of 20	Out of 15	Out of 15	Out of 15	Out of 15	Out of 10	Out of 5	Out of 5	Out of 100
1. IOT	Above Average	Above Average	Above Average	Excellent	Above Average	Excellent	Average	Excellent	72
	14	10	11	12	10	8	3	4	
2. Manual	Average	Average	Average	Above Average	Average	Excellent	Average	Below Average	61
	13	8	8	10	8	8	3.5	2.5	
3. IR	Average	Average	Below Average	Poor	Below Average	Poor	Above Average	Poor	36
	13	7	4	2	4	1	4	1	

### Particle Filtration system Using IR Sensor

**1. Microorganism detection:** Our main objective of this project is to detect the size of the particle. In design approach 1, we are using IR sensor which can detect 2.5µm, 5µm, 10µm sized particle. From literature review we got to know that IR sensor can detect till 2.5µm sized particle so this system can't give more precise result while detecting microorganism[12].

**2. Cost efficiency:** Here as a particle counter sensor we are using an IR sensor and the glass mounting chamber to place the mask. We are using glass as we need such a chamber that no air can pass through it.

**Table10:IR sensor cost**

Task	Component	Price(BDTK)
Particle detection	IR sensor	1000
Mounting chamber	Glass chamber	800

**3.Sustainability:**As we need such a device which can detect small size particles ,this system will fail to give us precise results based on particle size as for this system the minimum range of detected particle size is 2.5µm.

**4.Maintenance:**As this system has a simple structure so the maintenance is much easier than other devices.We need to ensure cleaning the dust from the device properly and upgrade the software if needed.

**5.Impact:**It gives secured communication due to line of sight or point-to-point mode of communication. The battery utilized in infrared gadgets is final for the long term due to lower control consumption. Infrared movement sensors identify movement in daytime and nighttime reliably. The sensor does not require any contact with the item to be detected. The infrared gadgets are more fitting for targets which are near than 10 mm. Infrared gadgets can be separated from delicate objects which may not be effectively identified by ultrasound. They are physically littler in measure and are more affordable. It has reaction time speedier than thermocouple. It gives great solidness over time. No erosion or oxidation can influence the precision of an infrared sensor. Infrared waves at high power can harm eyes. In screen & control applications, it can control as if it were one gadget at one time. Besides it is troublesome to control things which are not in LOS (Line of Locate). It requires a line of sight between transmitter and recipient to communicate. It bolsters shorter runs and subsequently its execution debases with longer distances. It bolsters lower information rate transmission compared to wired transmission[22].

### **Particle filtration system with Air Quality Indicator sensor**

**1.Microorganism detection:**In design approach 2,we are using PMS5003 which can detect 0.5µm,2.5µm,5µm,10µm sized particle.From literature review we got to know that PMS5003 that detect till 0.5µm sized particle so we will get way more precise result while detecting microorganism than IR based filtration system[11].

**2.Ozone gas detection:**After disinfecting the mask, we have to detect the presence of the ozone gas form mask .For this purpose we are using a gas sensor to detect the amount of any alcoholic gas.

**3. Temperature and humidity monitoring:** We have to monitor the temperature and humidity while operating the system and monitor the value in the LCD display .

**4. Cost efficiency:** Design approach 2 and 3 will cost similar amounts but design 3 has a facility of storing data and by comparing data we can get the precise result and also can define the efficiency of the mask before and after disinfecting it.

**Table 11: Filtration system using Air Quality Indicator sensor cost**

Task	Component	Price(BDTK)
Data collection box	DHT22	330
	MQ-135	160
	PMS5003	4000
Air controller	Vacuum pump	4050
	Flow controller valve	940
Mounting chamber	Glass chamber	800

**5. Sustainability:** As we need such a device which can detect small size particles ,this system will give us precise results based on particle size. For this system the minimum range of detected particle size is 0.5µm. As it's a manual system so there is some possibility of human error and we need manpower to monitor our system.

**6. Maintenance:** For routine maintenance we need to check a few things like cleaning the dust ,upgrading the software if needed .Also if any vacuum pump or machine is used then we have to maintain that properly.

**7. Impact:** Right presently, low-cost defilement checking is conceivable by means of particular commercial sensors and an advancement inside the reputation of the utilization of such contraptions is observed around the world. Sensors for particulate matter estimations are as well open in various sorts. The common highlight of all commercial PM sensors is the rule of operation—they degree light scattered by particles carried in a discrete stream through a light column. In spite of the truth that particulates may shift in beginning, chemical composition, shape, or surface range, the hurtful impacts of PM are ordinarily related to the estimate of particles. The particles with littler streamlined diameters have more prominent capacity to enter into the lower parts of the respiratory tract. Coarse PM (particles with within the range 2.5–10 µm) store primarily within the upper respiratory tract, and fine PM (particles with underneath 2.5 µm) store all through the respiratory tract and can enter to the lower parts and alveoli, though ultrafine particles (particles with underneath 0.1 µm) may cross the endothelial boundary and enter the blood [2–5]. The mass concentrations of PM10( underneath 10 µm) and PM2.5 ( underneath 2.5 µm) are broadly utilized for discuss quality standard foundation and for surveying the discuss contamination levels.  $R^2 > 0.71$  for 1-hour

information and  $R^2 > 0.77$  for day by day information for instruments with PMS5003 sensor[21].

### **IOT Based Particle Filtration System**

**1. Microorganism detection:** Our main objective of this project is to detect the size of the particle. In design approach 3, we are using PMS7003 which can detect 0.3 $\mu$ m, 0.5 $\mu$ m, 2.5 $\mu$ m, 5 $\mu$ m, 10 $\mu$ m sized particle. From literature review we got to know that PMS7003 that detect till 0.3 $\mu$ m sized particle so we will get more precise result while detecting microorganism[11].

**2. Ozone gas detection:** After disinfecting the mask, we have to detect the presence of the ozone gas from mask. For this purpose we are using a gas sensor to detect the amount of any alcoholic gas.

**3. Temperature and humidity monitoring:** We have to monitor the temperature and humidity while operating the system and store the data in a cloud server.

**4. Remote cloud server:** One of the main criteria of this project is to store the data in a cloud server as we are doing a project based on IOT. In design approach 3, we were able to store the data in the IOT cloud for future use purposes[11].

**5. Cost efficiency:** Design approach 2 and 3 will cost similar amounts but design 3 has a facility of storing data and by comparing data we can get the precise result and also can define the efficiency of the mask before and after disinfecting it.

**Table12:IoT based filtration system cost**

<b>Task</b>	<b>Component</b>	<b>Price(BDTK)</b>
Data collection box	DHT22	330
	MQ-131	1450
	PMS7003	4000
	ESP32S	380
Air controller	Vacuum pump	4050
	Flow controller valve	940
Mounting chamber	PVC chamber	200

**6.Sustainability:**As we need such a device which can detect small size particles ,this system will give us precise results based on particle size. For this system the minimum range of detected particle size is 0.3 $\mu$ m.Also as it's an automated system so the possibility of error is less in this system.

**7.Maintenance:**As this system has a complex structure, we need proper maintenance. Here we are using a vacuum pump which need maintenance like we need to check if the oil tank is full or not .Also we need to be careful about the sensors as we are connecting them with same esp so we have to check there power capacity properly.For routine maintenance we need to check few things like cleaning the dust ,upgrading the software if needed .This maintenance is affordable and we can ensure that our device is working properly.

**8.Impact:**Right now, low-cost contamination checking is conceivable by means of distinctive commercial sensors and a development within the notoriety of the utilization of such gadgets is watched around the world. Sensors for particulate matter estimations are too accessible in numerous sorts. The common highlight of all commercial PM sensors is the guideline of operation—they measure light scattered by particles carried in a discrete stream through a light pillar. Costs of such optical sensors run from tens to hundreds of US dollars, since they are by and large cheap to fabricate. In expansion, PM sensors are simple to utilize and in many cases prepared to associate to microcomputers. Since then, they are regularly received for use by citizen researchers. Another advantage of optical PM sensors is the moo vitality consumption—they require control supply voltage at the level of 5 V, and the working current is as a rule lower than 250 mA.They are moreover generally little and light, and the yield information may be collected with tall recurrence.The prior forms of Plantower sensors (i.e., PMS1003, PMS3003, and PMS5003) were assessed as promising devices for PM2.5 observing be that as it may, high discuss humidity impacted the sensor yields .Conditions of a high air humidity can influence the execution of optical PM sensors in a few ways. The primary gathering of issues is related to a disappointment of the electronic circuits in an awfully damp environment. This may lead to one-sided estimation or harm of sensors . The moment bunch of issues is related with molecule properties and the rule of operation of light-scattering gadgets. The other perspective of calibration is related to linearity of sensor reactions. In specific, PMS7003 sensors come to R<sup>2</sup> higher than 0.8 for short-time averaging times and surpassed 0.9 for every day midpoints[21].

### **SWOT Analysis of Optimal Design Solution:**

Based on our optimal solution,we performed SWOT analysis in Table 13.



**Table 13:SWOT Analysis of Optimal Design Solution**

	Positive	Negative
	Strength	Weakness
Internal	1. Cost effective 2. IoT based system 3. Developed with advanced Technologies/sensors 4. Can detect micro particles and monitor efficiency after filtration 5. Can deliver more accurate result 6. Will store our finding data in the cloud 7. Can monitor real time data from anywhere.	1. Unavailability of some resources(sensors) in our region.
	Opportunities	Threats
External	1. Because it offers more advanced functions than other available nanoparticle detecting systems, it has less competition. 2. Because it is less expensive than other similar devices, it has less rivalry and more potential.	1. Because improved resources, such as sensors, are not accessible in our region, others can outperform us by utilizing advanced resources and technology.

#### **4.5 Conclusion**

Given that it uses a WiFi-capable IoT (Internet of Things) controller to manage the sensors and uses serial connection for data transfer, IOT-based particle filtering stands out as the best option among the alternatives. We will also receive a more accurate result if we use contemporary sensors. Data can also be stored on cloud servers by IOT, whose use has recently expanded somewhat. People are ready to use IOT to do any type of checking handle because of its growing popularity and appeal.

## Chapter 5[CO8]

### Completion of Final Design and Validation

#### 5.1 Introduction

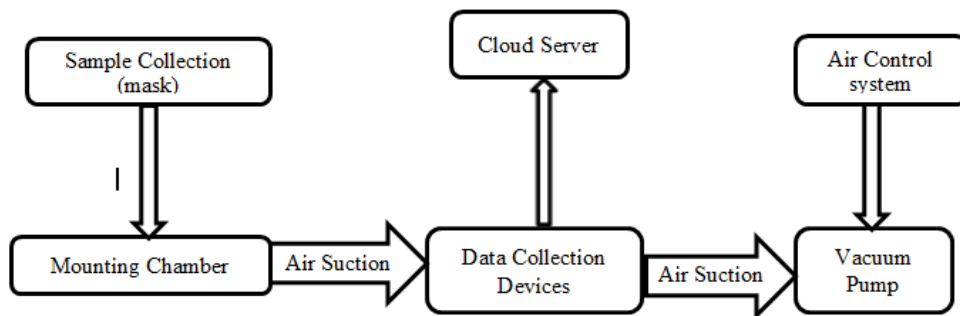
After Covid-19, the use of masks has increased in a huge amount. Also the air of our environment has polluted in a huge level. So it's become necessary to wear mask in our day to day life. But to ensure our mask efficiency we need to check whether it can suction the air particles from the weather or not. With the help of contemporary advances, testing the cover is investigating imaginative ways to gather information and test its effectiveness. Each attainable way has both preferences and impediments. We are required to choose the one that will provide us with the foremost yield with the least flaws among them. Here we have introduced three conceivable arrangements to the woodland checking framework in detail and came up with one ideal arrangement which is the IOT Based Particle Filtration System. Recently, use of IOT has expanded a parcel because it has the capacity to store information in cloud servers. Due to its expanding demand and points of interest, individuals are willing to utilize IOT to conduct any sort of checking handle.

#### 5.2 Completion of final design

##### 5.2.1 Design Methodology and Design Process

In order to measure the productivity of different therapeutic covers and respirators, it is vital to monitor the drop in particulate concentration to discuss passing through the channels beneath conditions that imitate those beneath characteristic utilization. Any veil filtration productivity test setup requires to subject a sheet of the cover fabric of settled area (or the complete veil, regularly mounted on a human confront model), to a flux of  $0.3\mu\text{m}$  sized particles (for N95) and degree the throughput of such particles over the veil. Whereas commercial setups would have in-built vaporized generators for a craved molecule measure, there are regularly enough residual sub-micron and micron-sized particles in room air itself that can be utilized. Subsequently any device that can check the number of particles in air can be valuable to check transmission through a mask. Given the interest in air quality estimations, particularly in contaminated cities, air-quality- indicator (AQI) frameworks are presently broadly sent. Most of these are planned to degree PM<sub>2.5</sub> and PM<sub>10</sub> levels (of  $2.5\mu\text{m}$  and  $10\mu\text{m}$  measured particles). Be that as it may numerous such AQI frameworks are based on laser particle counter sensors (just like the Plantower PMS 1003/5003/7003 series<sup>10</sup>) that really provide measurements of molecule checks at 0.3, 0.5, 1, 2.5, 5 and  $10\mu\text{m}$  as standard yields. These sensors are optimized for the discovery of  $2.5\mu\text{m}$  measured particles and have been broadly tested<sup>11</sup>. Though the affectability of the PMS 7003 at  $0.3\mu\text{m}$  is significantly less than at  $2.5\mu\text{m}$ , it is sensible enough for dependable estimations. Be that as it may, in any case the supreme affectability isn't basic for a mask test application as the parameter of intrigued could be a proportion of estimations. As we have set our device in our

university R&D lab so at we routinely observed discuss quality of our lab to distinguish the mount of particles in the 0.3, 0.5, 1,2.5 and 10  $\mu\text{m}$  measure containers employing a PMS7003 molecule counter.We made the air passing through the PMS7003 using XZ-1A vacuum pump.Also to control the pressure we used air control valve.We used PVC board to make our mounting chamber air tight.We also used an oval shaped ball and bored a vent hole “mouth”, and put the N95 respirators over the opening.We also connected the pipes though the mounting chamber to the data collection box and from data collection box to pump.After starting the pump we fixed the pressure around 6 liter/min like human breathing.When pump started the air suction,the particles present in the air suction through the mask chamber.Our PMS7003 sensor counts the air particles passing through.Figure 17 depicts a workflow design, and Figure 18 shows our complete arrangement.The filtration efficiency, mask, can be decided from the proportion of particles per unit time identified with, N1, and without the cover connected, N2, as  $\eta$  mask = 1 – (N1 / N2).We used C-programming language to synthesize the sensors with each other. We used Arduino IDE to compile and upload the code.



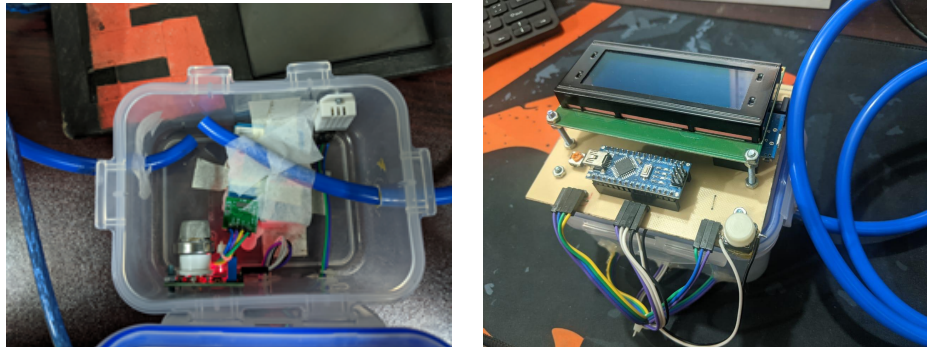
**Figure17:Workflow diagram**



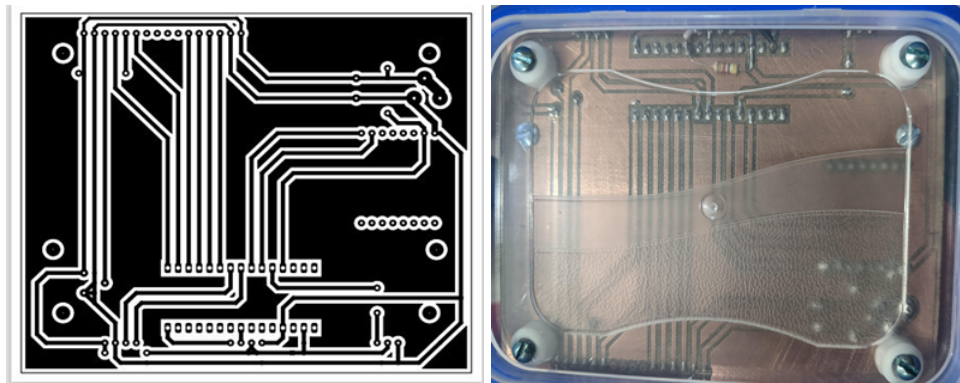
**Figure18:Full set-up of IoT Based Microorganism Detection and Filtration System**

Figures 19 and 20 show images of the data collection device and our PCB design layout, respectively. Along with particles, we also needed to monitor the temperature and humidity. There is a UV-light disinfection chamber at our research and development facility. We have been analyzing the Ozone range using the MQ131 sensor. Our cover PFE test setup consists

of a DHT22, a MQ131, and a Plantower PMS7003 sensor. An ESP D1 WiFi micro controller unit controller with an Arduino nano center compatible with the Arduino IDE controls them all on a small scale. The system is remotely powered using a standard micro-USB connector on the ESP D1 mini board. For PCB layout, we used Proteus 8 Professional.

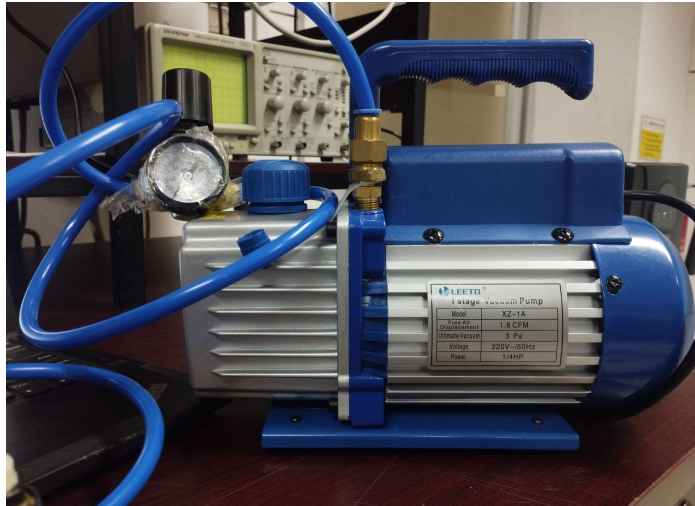


*Figure19:Data collection box ( PMS7003,DHT22,MQ131)*



**Figure20:PCB board design**

A vacuum pump is a machine that expels air or gas from a sealed space in order to create a partial vacuum and a difference in pressure. Based on the pressure needs and the application it serves, vacuum pumps are designed using a range of technologies. Sizing to the proper parameters is essential when configuring a vacuum pump system to ensure maximum efficiency. Vacuum pump technology can be classified as wet or dry depending on the pressure needs and operational application. Dry pumps contain no fluid between the revolving mechanisms or static parts that are used to isolate and compress gas molecules, whereas wet pumps require oil or water for lubrication and sealing. Dry pumps require extremely high tolerances to function properly and wear-free without lubrication. The model we are using for our experiment is XZ-1A, shown in Figure 21 which is an oil controlled vacuum pump with a maximum flow rate of 50 liters per minute, the XZ-1A. With a flow controller valve, the flow may be monitored and managed. We employed a flow rate of 6 liters per minute fixed for the experiment, which was intended to mimic human breathing patterns.



**Figure21: Vacuum pump XZ-1A**

We made a mounting chamber and it's standard test area is  $14*12*7\text{cm}^3$  like Figure 22 using PVC board to make the chamber air tight and inside it we placed an oval shaped ball to make it look like a face. It represents a human face.

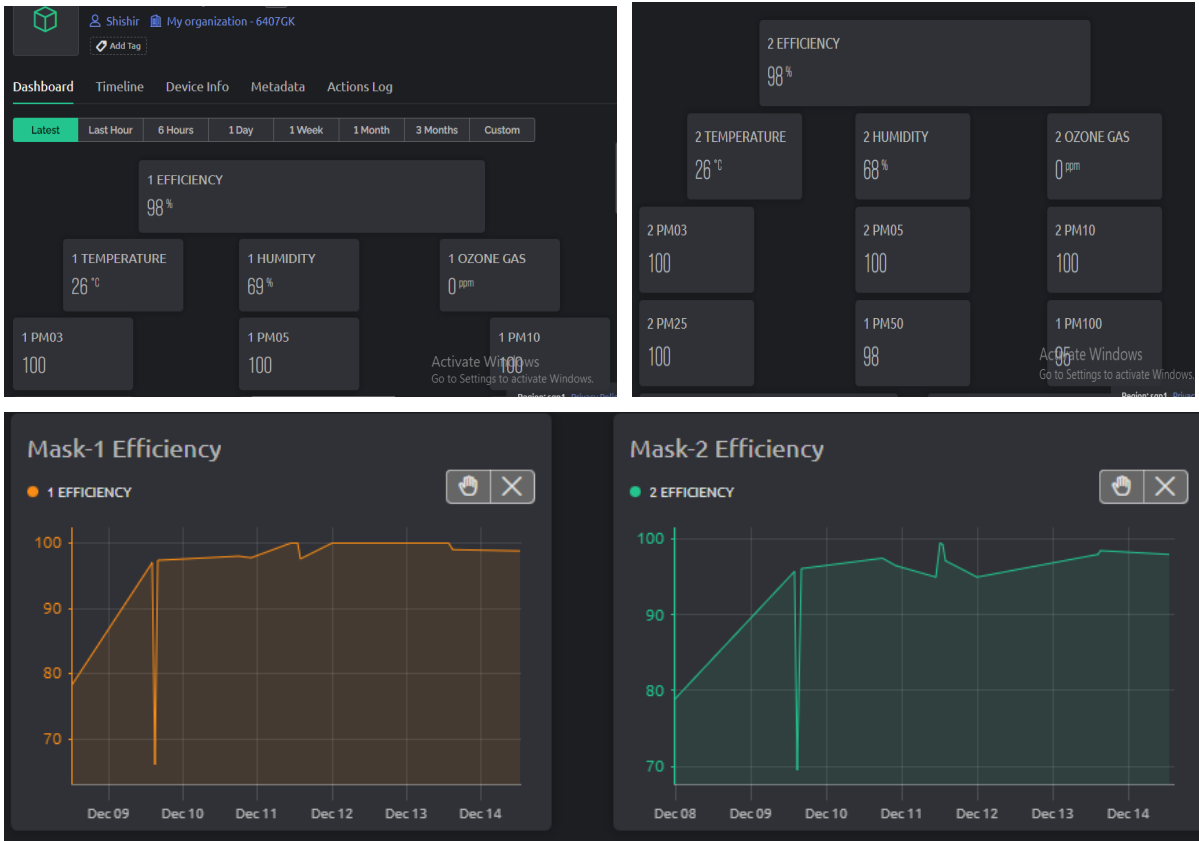


**Figure22: Mounting chamber**

### **5.2.2 Data Collection and Analysis**

To monitor the data in a cloud server, we are using BLYNK server shown in Figure 23, which is an Internet of Things platform for iOS or Android devices that allows users to remotely operate Arduino, Raspberry Pi, and NodeMCU over the Internet. It can store information, visualize it, present sensor data, remotely control equipment, and perform many other fascinating things. We designed Blynk server in such a way that it can monitor the amount of particles, efficiency and Ozone gas. Also this server stored previous data and also shows the previous efficiency results.





**Figure23: BLYNK cloud server for monitoring data and efficiency**

Figure 24 shows how we view our data on the LCD display here which is a flat-panel display or other electronically controlled optical device that makes use of polarizers and the light-modulating capabilities of liquid crystals is known as a liquid-crystal display (LCD). Liquid crystals don't directly emit light; instead, they create color or monochromatic pictures using a backlight or reflector. On the display we can see temperature, humidity, Ozone gas, particle counting and efficiency.



**Figure24:LCD monitoring data and efficiency**

At first we collected data without placing the mask in the chamber as we wanted to check the air quality of the R & D lab. We took the value as we will set those values as a benchmark

while checking mask performance. We took data for 3 times and took the average of it to set our benchmark.

**Table14:Data without placing the mask in chamber**

Date	pm 0.3 μm	pm 0.5μm	pm 1μm	pm 2.5μm	pm 5μm	pm 10μm	Ozone(ppm)
13/12/2022	190	185	150	128	110	95	0.00
13/12/2022	200	170	145	126	118	100	0.01
14/12/2022	195	175	148	130	120	100	0.00

We initially sought to evaluate the surgical mask's functionality. We next took the data and inserted it in Table 14 after placing the surgical mask in the mounting chamber.



**Figure25:Surgical mask**

**Table15:Data placing mask in chamber**

Date	pm 0.3μm	pm 0.5μm	pm 1μm	pm 2.5μm	pm 5μm	pm 10μm	Ozone (ppm)	Efficiency (%)
13/12/2022	100	100	100	98	94	88	0.00	94
13/12/2022	100	100	98	98	90	89	0.00	96
13/12/2022	100	100	100	98	96	90	0.00	92
14/12/2022	100	100	98	98	89	88	0.01	96
14/12/2022	100	100	100	94	94	89	0.01	92
14/12/2022	100	100	96	92	89	88	0.00	97

We collected the data again after employing the mask for 6-7 hours, as shown in Table16.

**Table16:Data After using mask 6-7 hours**

Date	pm 0.3 $\mu$ m	pm 0.5 $\mu$ m	pm 1 $\mu$ m	pm 2.5 $\mu$ m	pm 5 $\mu$ m	pm 10 $\mu$ m	Ozone (ppm)	Efficiency (%)
13/12/2022	127	118	107	98	98	92	0.00	89
13/12/2022	120	111	105	96	90	90	0.00	91
13/12/2022	123	117	110	98	96	90	0.00	89
14/12/2022	129	114	107	99	96	88	0.01	88
14/12/2022	125	114	110	100	94	89	0.01	88
14/12/2022	128	115	100	96	92	88	0.00	88

From data ,we can observe that more particles are detected by our device as more particles are present in the mask surface.Then we used our disinfecting chamber and disinfected the mask.Figure 26 depicts the disinfection chamber from both the inside and the outside.



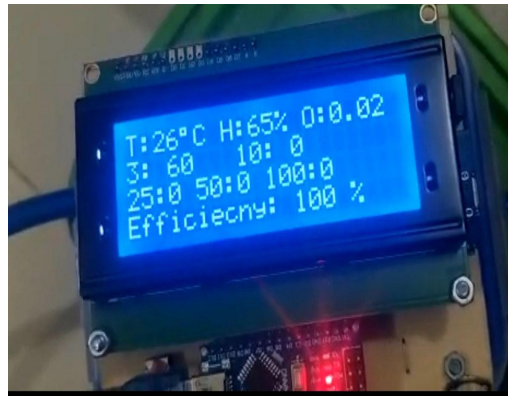
(a)



(b)

**Figure26: Disinfecting chamber inside(a) and (b)inside look**





**Figure 27:Data display in LCD**

After cleaning the mask, we collected the data once more to determine whether it had been properly cleaned; the results are shown in Table 17. After analysis we saw that a very few particles were detected by our device. Also we detected the ozone gas which is 0.02ppm shown in Figure 27 as we used the disinfecting chamber. So from the analysis we can reach to the conclusion that the mask is disinfected and few small particles are present in the mask surface.

**Table17:Data After disinfecting mask**

Date	pm 0.3µm	pm 0.5µm	pm 1µm	pm 2.5µm	pm 5µm	pm 10µm	Ozone (ppm)	Efficiency (%)
13/12/2022	60	0	0	20	0	0	0.02	100
13/12/2022	72	10	0	0	10	0	0.02	99
13/12/2022	60	30	20	0	0	0	0.02	98
14/12/2022	74	20	10	0	0	0	0.02	100
14/12/2022	62	10	0	0	0	0	0.02	99
14/12/2022	65	10	0	0	0	10	0.02	99

Once more, we used the same process for the KN95 mask, and the outcomes are reported in Tables 18, 19, and 20 accordingly. Figures 29, 30, 31 and 32 show the outcomes for both masks.



**Figure28:KN95 mask**

**Table18:Data placing mask in chamber**

Date	pm 0.3µm	pm 0.5µm	pm 1µm	pm 2.5µm	pm 5µm	pm 10µm	Ozone (ppm)	Efficiency (%)
13/12/2022	100	100	98	96	92	88	0.00	95
13/12/2022	100	98	94	94	90	89	0.00	97
13/12/2022	100	100	100	98	96	90	0.00	96
14/12/2022	100	100	98	98	89	88	0.01	96
14/12/2022	100	100	98	94	94	89	0.01	95
14/12/2022	100	100	96	92	89	88	0.01	97

**Table19:Data After using mask 6-7 hours**

Date	pm 0.3µm	pm 0.5µm	pm 1µm	pm 2.5µm	pm 5µm	pm 10µm	Ozone (ppm)	Efficiency (%)
13/12/2022	127	118	107	94	98	92	0.00	90
13/12/2022	122	112	105	96	90	90	0.00	91
13/12/2022	126	117	110	98	96	90	0.00	89
14/12/2022	124	114	107	99	96	88	0.01	88
14/12/2022	125	114	107	96	94	89	0.01	88
14/12/2022	126	113	98	96	92	88	0.00	90

**Table20:Data After disinfecting mask**

Date	pm 0.3µm	pm 0.5µm	pm 1µm	pm 2.5µm	pm 5µm	pm 10µm	Ozone (ppm)	Efficiency (%)
13/12/2022	60	0	0	0	10	0	0.02	100
13/12/2022	65	10	0	12	0	0	0.02	99
13/12/2022	60	30	17	0	0	0	0.02	98
14/12/2022	56	0	0	10	0	0	0.02	100
14/12/2022	62	10	0	0	0	10	0.02	99
14/12/2022	65	10	0	0	10	6	0.02	99

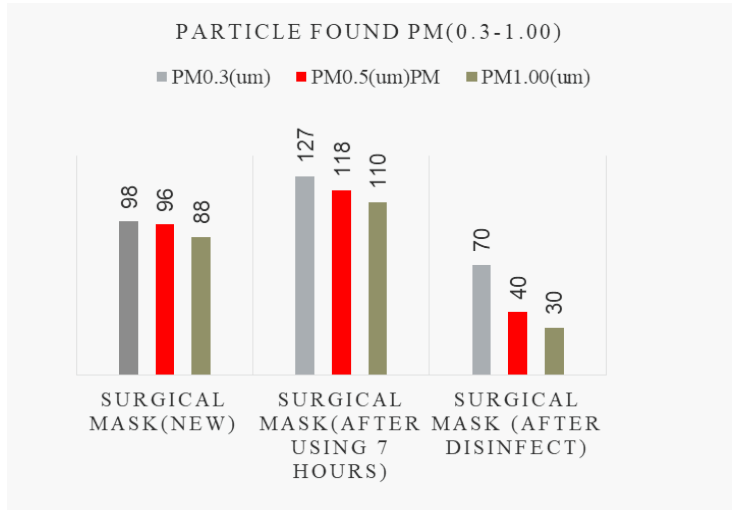


Figure29:Graphical representation of particles for surgical mask(particle size 0.3um-1.00um)

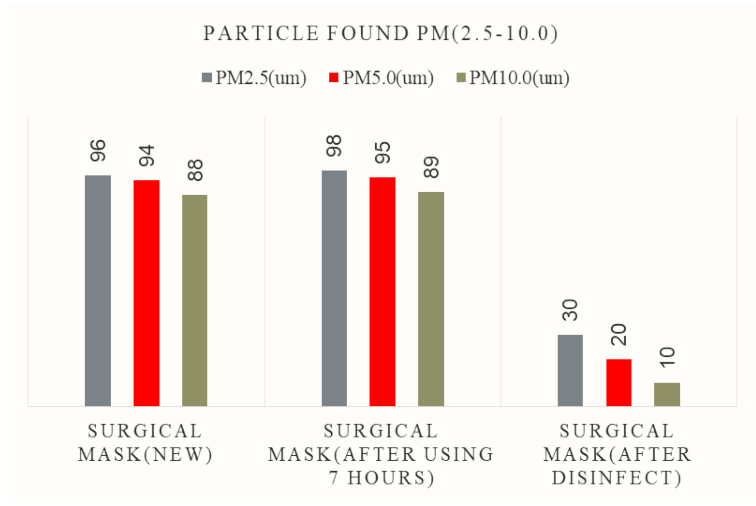


Figure30:Graphical representation of particles for surgical mask(particle size 2.5um-10.0um)

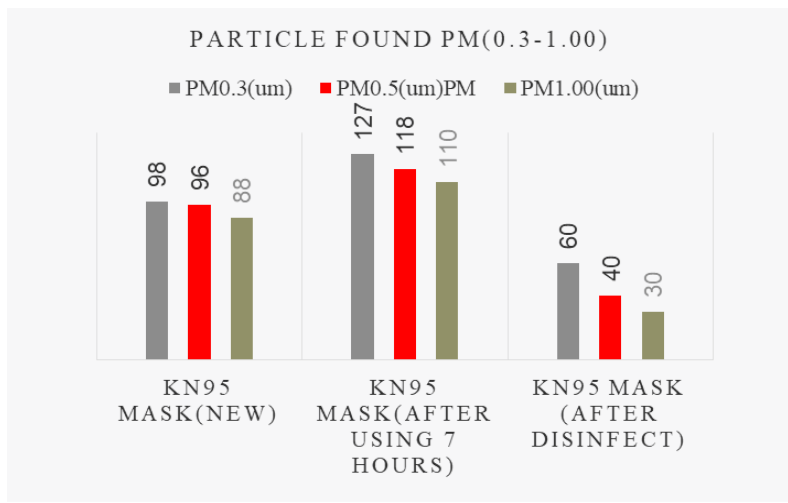
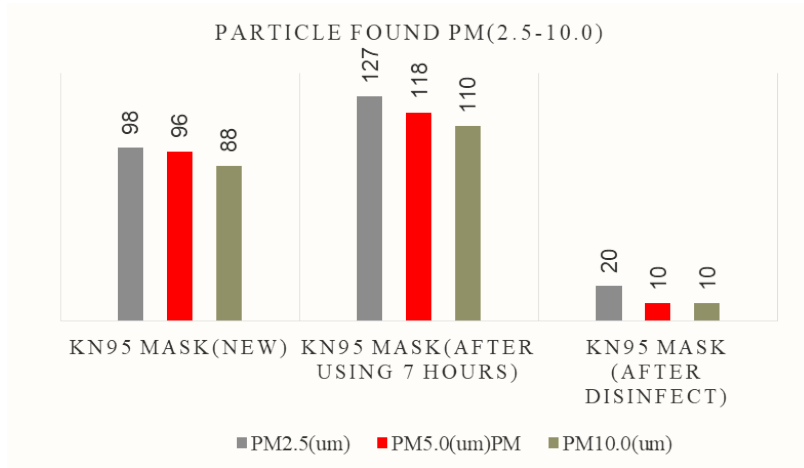
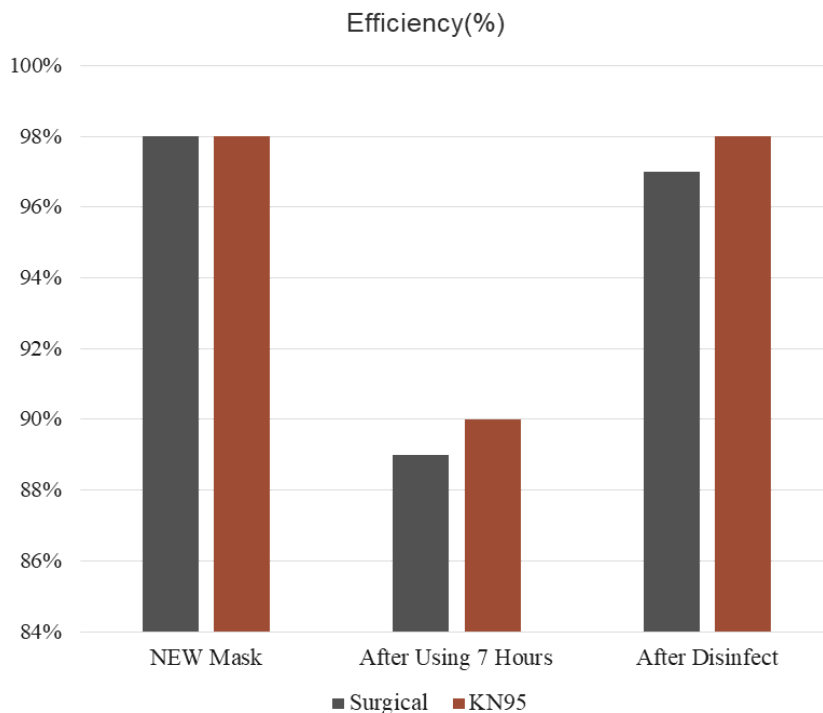


Figure31:Graphical representation of particles for KN95 mask(particle size 0.3um-1.00um)



**Figure32:Graphical representation of particles for KN95 mask(particle size 0.3um-1.00um)**

After examining various particles, we evaluated the functionality of both surgical and KN95 masks, as shown in Figure33..From the analysis we found out that KN95 has little bit better performance than surgical mask.On average both new surgical and KN95 mask has around 98% efficiency.After using both for several hours we compared the efficiency again.Surgical mask has 89% efficiency whereas KN95 mask has 90% efficiency.Again after disinfecting we found that surgical mask has the efficiency around 97% whereas KN95 has efficiency around 98% .We found this ratio after one time use and disinfection analysis.



**Figure33:Graphical representation of efficiency of KN95 and surgical mask**

We also put an observation on Ozone gas. After using a disinfecting chamber we found a small amount of Ozone gas present in the room and inside the chamber which is 0.02ppm which is shown in Figure34. This small amount of Ozone gas is not that much harmful for human beings.

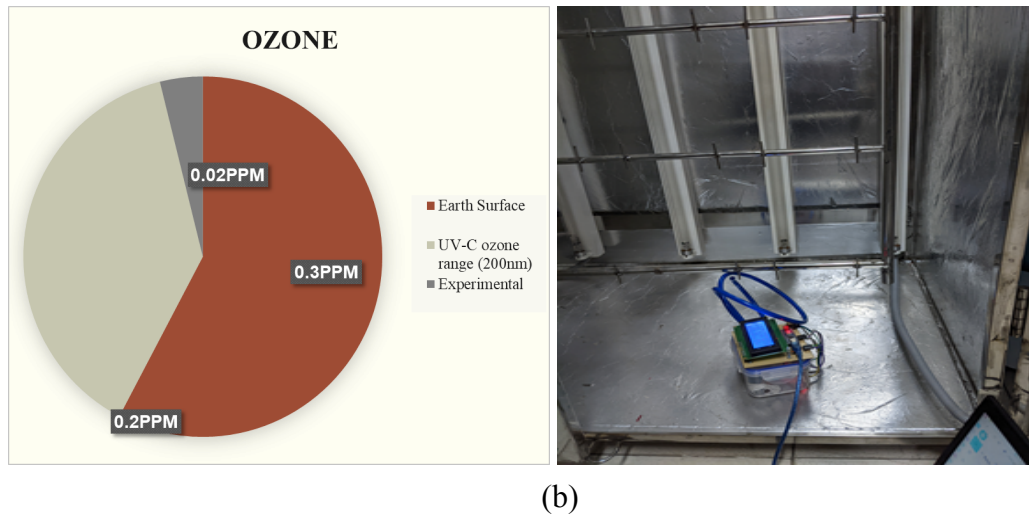


Figure34:Graphical representation of Ozone gas(a) and device placed inside disinfecting chamber(b)

UV light, a form of radiation that can pass through the protective layers of organisms like skin, is well-trapped by ozone. In turn, this might harm animal and plant DNA molecules. UVB and UVA are the two main subtypes of UV light. Skin diseases like sunburns and malignancies like basal cell carcinoma and squamous cell carcinoma are brought on by UVB[31]. So we need to ensure the safety in terms of using disinfection chamber

### 5.3 Evaluate the solution to meet desired need

During Covid-19, the use of masks increased at a level that people needed to reuse it. But it was necessary to ensure the performance of the mask before reusing it. Though the covid wave has improved but still it is necessary to wear the mask day to day life for protecting ourselves for further impact. Also people with dust allergy wears mask regularly. So we designed a device which can check the efficiency of the mask. Society benefited greatly from the adoption and use of current developments in IOT and sensor technology, which increased worker safety and other operational efficiencies. We evaluate three various designs for our project before deciding on the ideal one for our monitoring method, which can more effectively satisfy the required demand than the others. We can now determine the mask performance after successfully implementing the model for our sensor data and mask efficiency.

We may gather information about the air quality and use C programming to examine the mask performance, as we saw in the data gathering section.

However, we have chosen several significant design elements that can have a direct impact on the economy of our area. Which studies address which topics are listed in the table21 below.

**Table21: Project Object**

<b>Basis</b>	<b>IOT based microorganism detection and filtration system</b>
Air particle measurement	Possible
Ozone gas detection	Possible
Data store	Possible

Our ultimate objective is to keep an eye on the air quality and give specialized authority a general concept of the mask's state. We will thus now assess how well our study satisfies our desired needs. This evaluation is shown in Table22.

**Table22 : Evaluate the Model results with the desired needs**

<b>Objectives</b>	<b>Procedure</b>	<b>Result</b>	<b>Fulfill desired need (YES/NO)</b>
Air particle measurement	Collect air samples through air sensors. Analysis of the data	Get the amount of different sized particle	YES,
mask efficiency test	By analyzing data it can show the efficiency of the mask	Got efficiency around 96-98%	YES,
Ozone detection	Can detect ozone gas present in the room	Got 0.02ppm ozone after using disinfecting chamber	YES,
Store Data	All the values will be stored in a cloud server	Can see previous data stored in server	YES

According to the inspection of each one of our project plans, we succeeded in achieving them all. In order to remain competitive in the contemporary world, we are focusing our idea on the growing demand for IOT in the globe today. We will have access to and be able to store the information on a cloud server.

### 5.1.3 R&D lab monitoring and mask efficiency

We put up the device in an air-conditioned, enclosed lab, so we had to evaluate its temperature and humidity before starting our experiment. We're using our UV chamber for this experiment, so the temperature and humidity change occasionally. Ozone concentration also rose in tandem with it.

**Table23: Analysis of collected data**

<b>R&amp;D lab Condition</b>			
<b>Components</b>	<b>Parameters</b>	<b>Units</b>	<b>Range</b>
Air	Temperature, T	°C	$24 < T < 26$
	Humidity, Hm	g/kg	$50 < Hm < 70$
	O3	ppm	$0 < O3 < 0.01$

We also monitored the temperature, humidity, and ozone concentration in the disinfection chamber before and after use.

**Table24: Analysis of collected data**

<b>Disinfecting chamber Condition</b>			
<b>Components</b>	<b>Parameters</b>	<b>Units</b>	<b>Range</b>
Air	Temperature, T	°C	$25 < T < 30$
	Humidity, Hm	g/kg	$60 < Hm < 70$
	O3	ppm	$0 < O3 < 0.02$

The effectiveness of the mask declines with each use. After testing a fresh mask's effectiveness, we noticed that it had lost some of it after using it for a while. It will not be able to protect us if we clean it and re-use it a few times.

**Table25: Analysis of mask efficiency**

<b>Mask of Name</b>	<b>Efficiency(%)</b>	<b>Condition</b>
Surgical mask	<ul style="list-style-type: none"><li>● 96-98</li><li>● 88-90</li><li>● 80-85</li></ul>	<ul style="list-style-type: none"><li>● New mask</li><li>● after using 6-7 hours</li><li>● after disinfecting 2 times</li></ul>
KN95	<ul style="list-style-type: none"><li>● 96-98</li><li>● 89-91</li><li>● 80-85</li></ul>	<ul style="list-style-type: none"><li>● New mask</li><li>● after using 6-7 hours</li><li>● after disinfecting 2 times</li></ul>

In order to protect against COVID-19, using a worn mask may be more hazardous than not wearing one at all, according to a recent study. According to a study published on Tuesday in the Physics of Fluids, a novel three-layer surgical mask is 65 percent effective in filtering airborne particles, but when it is worn, that efficiency falls to 25 percent. A dirty face mask can't efficiently filter even the smallest drops, according to researchers from the University of Massachusetts Lowell and California Baptist University, who also claim that masks slow down airflow, leaving people more prone to breathing in particles.[23] So according to research, it is risky to reuse the mask as the performance drops after using it one time.

#### **5.4 Conclusion**

Mask usage escalated to the point where it was necessary for people to reuse them during COVID-19. But before utilizing the mask again, it had to be tested for functionality. Even if the COVID wave has gotten better, it is still vital to wear a mask every day to protect ourselves against future impacts. People who have a dust allergy frequently wear masks. So, we created a tool to evaluate the mask's effectiveness. The acceptance and utilization of recent breakthroughs in IOT and sensor technologies, which boosted worker safety and other operational efficiencies, tremendously benefited society. According to a recent study, using a used mask to defend against COVID-19 may be riskier than not using one at all. Researchers also assert that masks slow down airflow, making people more susceptible to breathing in particles. Reusing the mask is therefore dangerous, as its effectiveness declines after just one use.



## Chapter 6[CO3, CO4]

### Impact Analysis and Project Sustainability

#### 6.1 Introduction

IOT systems are becoming more and more well-known. It is vital to retain the data for later use as we are detecting airborne particles, checking mask performance, and other tasks. This research will have an effect, and as the use of masks expanded following COVID-19, we made sure that our gadget could evaluate data to assess the mask's performance.

#### 6.2 Assess the impact of solution

##### Health Context

As we live in a developing country like Bangladesh, our optimal design solution has a great impact on health issues by ensuring disinfecting face masks for each and every citizen of this country in this covid situation.

Our optimal design can detect the different kinds of microparticles as well as microorganisms like bacteria, airborne etc from a used mask. This device can make people health conscious by notifying them about their mask performance by determining filtration efficiency so that people can reuse and change masks whenever needed[1].

##### Social Context

Our project has a significant impact on our social context.

1. Instead of throwing away a face mask, reusing it by disinfecting it and assuring its disinfection rate with our optimal solution may decrease the environmental load and wasted products from our environment[2].

2. A face mask can be a cost-effective solution if it's used repeatedly. In Bangladesh, where resources are scarce, wearing a face mask repeatedly while disinfecting it and keeping track of its level of disinfection might save a significant amount of cash[4].

##### Safety Context:

Our project has a significant impact on our social context.

1. Uncovered potentially dangerous chemical pollutants that are released from disposable face masks when submerged in water which are harmful for human beings. So, if we use a face mask several times it will reduce these types of pollutants than before[1].

2. Disinfected face and high filtration efficiency masks can assure people to lead a risk free life from various types of airborne disease, dust allergies [2].

### **6.3 Evaluate the sustainability**

Our primary goal is the IoT-based detection and filtering of microorganisms using the PM sensor. We are utilizing PMS7003, which can detect particles that are 0.3, 0.5, 2.5, 5, and 10 microns in size. [11]. Our device is superior to other ones on the market in terms of efficiency. Our project is also considerably simpler, more affordable, and better suited for everyday use. This can more effectively detect the particle than other methods and gather a variety of data, including temperature, humidity, and ozone gas. We have the chance to store data in the cloud, therefore we utilized the Blynk cloud server, which also allows for real-time monitoring. Additionally, compared to other types of filtration and efficiency systems, it saves time and the data acquired offers greater accuracy.

#### **6.3.1 Maintainability and Manufacturability**

We require appropriate maintenance because the structure of this system is complex. Here, we're employing a vacuum pump that requires maintenance, such as checking to see if the oil tank is full. Additionally, as we are connecting the sensors to the same esp, we must appropriately assess their power capacity. Cleaning the dust and, if necessary, updating the software are a few items that need to be checked as part of routine maintenance. We can make sure that our item is operating properly and this maintenance is inexpensive. We must be aware of the sensor as well since if the power supply is more than 5V, the sensors could be harmed. We need to regularly clean the mask mounting chamber because if dust gets into the mount, we won't get accurate particle data or efficient operation. We must also take care with the data gathering box, which needs to be airtight. Maintaining the safety ratio is important when we examine the mask after disinfecting it. We also need to be cautious when using cloud servers. The primary means of endangering someone these days is through server attract. We must be cautious when it comes to cyber security. Our security system needs to be updated and checked constantly to ensure that no one is stealing our data.

#### **6.3.2 Sustainability**

This method will provide us with accurate findings based on particle size since we require a device that can detect small size particles. The minimal range of detected particle size for this system is 0.3 mm. Additionally, since this technique is automated, there is less chance for error.

Ironically, however, there is a serious gap in our understanding of the value and long-term viability of mask filtering. We can determine from an analysis of our project that it satisfies all requirements and is sustainable. It met the need for microparticle detection, post-filtration

efficiency monitoring, and more precise results. It contains features for monitoring data in real time and is also economical. Although some resources (sensors) are not readily available in our area, it has less competition and more advanced features than other nanoparticle detecting systems that are already on the market. A weighted decision matrix for technology analysis, depicted in Table 26, was used to assess our performance.

**Table:26 Weighted Decision Matrix For Technology Analysis**

<b>Sustainability criteria Process</b>	<b>Technical (25)</b>	<b>Economic (25)</b>	<b>Social (25)</b>	<b>Environment (25)</b>	<b>Weighted sum(100)</b>
<b>Designing</b>	25	10	15	15	65
<b>MicroOrganism Detection</b>	25	15	15	25	70
<b>Mask Filtration</b>	25	20	10	25	80
<b>Device Operation</b>	20	15	10	10	55
<b>Accuracy</b>	20	15	15	15	75
<b>Data Store</b>	25	10	10	10	55

## 6.4 Conclusion

In conclusion, we can state that the system for detecting and filtering microorganisms allows for the use of masks even after disinfection. They will be used to compare efficiency and provide detection and filtering data. From the above analyzing data we can conclude that our device met all the requirements (social impact, health impact, safety impact) and sustainability.

## Chapter 7[CO11, CO14]

### Engineering Project Management

#### 7.1 Introduction

Engineering project management is project management that is solely focused on engineering projects. For all types of project management, the fundamental methods and techniques are the same. This specialty is probably interesting to anyone with an engineering background who wishes to work in project management. Project management for engineers entails meticulous preparation and dissemination of that strategy to an engineering team. It entails identifying the project's objectives and checkpoints as well as creating various scenarios and backup plans. It's a crucial step for every engineering team since without it, the unanticipated could happen and prevent dozens or even hundreds of employees from finishing their task. Engineering project management is complex and requires administrative, interpersonal, and organizational skills. There are numerous logistical factors to consider in engineering project management. To keep everyone involved on the same page, the project manager must be able to plan out and steer the course of a project. Of course, in the event that something goes wrong, the project manager must be able to quickly and cheaply resume work on the project.

#### 7.2 Define, plan and manage engineering project

Since the beginning, we have followed a few project plans to complete the project, as illustrated in Figures 35, 36, and 37. In order to achieve our predetermined objective, it was crucial to manage the project plan. To finish this project within the three semesters of FYDP-P, FYDP-D, and FYDP-C, we had to carefully prepare our strategy.

Project Plan															
EEE-400P															
Task name	Responsibility	Week1	Week2	Week3	Week4	Week5	Week6	Week7	Week8	Week9	Week10	Week11	Week12	Week13	Week14
Topic Selection	Everyone														
Literature review	Jafree														
Tentative problem statement and tentative objective	Nuren & Jafree														
Multiple Design approach	Shishir & Nuren														
Specification, Requirements and Constraint Analysis	Nuren & Jafree														
Applicable Standards and codes	Shakil														
Progress presentation 1	Everyone														
Concept Note Drafting	Shishir & Jafree														
Optimal Solution finding	Nuren & Jafree														
Equipment Selection	Everyone														
Budget and Planning	Shishir & Nuren														
Sustianability	Shakil & Shishir														
Ethical considaration ans Risk Management	Everyone														
Progress presentation 2	Everyone														
Progress presentation 3	Everyone														
Project prop[osal report	Everyone														

**Figure35: Project Plan of EEE-400P**

From the very beginning of the semester, we adhered to our project plan for FYDP-P and carefully pursued its completion. Before starting to hunt for the problem statement over the course of the following two weeks, we divided up the work for the project's first week. After finishing the literature review, Jafree explained everything to us. Then, Jafree and Nuren worked together to draft preliminary problem descriptions and goals. We next go to the various design strategies used by Shishir and Nuren. From week eight to week nine, Nuren and Jafree concentrated on definition, requirements, and constraint analysis. In weeks 9 and 10, Shakil additionally worked on pertinent laws and regulations. We finished our progress presentation and wrote our idea note in week 10. We focused on the best solution, equipment selection, and budget planning after the presentation. We all focused on risk management and ethical consideration as we prepared for the 400-P final presentation in 13 weeks after Shakil finished writing about sustainability. By the end of last week, we had finished all of the assigned work.

EEE-400D															
Task Name	Responsibility	Week1	Week2	Week3	Week4	Week5	Week6	Week7	Week8	Week9	Week10	Week11	Week12	Week13	Week14
		Design of Multiple Alternative Solution	Shishir & Nuren	█	█										
Perform Simulation of Alternative Design solutions	Shakil & Jafree		█	█	█										
Optimal Solution Analysis	Nuren				█	█									
Hardware Implimentation of Optimal Solution	Everyone					█	█	█							
Code and Algorithom Development	Nuren & Shakil							█	█						
Compilation of hardware and algorithm	Shishir & Jafree								█	█	█				
Documentation	Everyone										█	█			
Preparing Draft Report	Everyone										█	█			
Preparing for Design Presentation	Shishir & Nuren											█	█		
Project Design Report	Everyone													█	█

Figure36: Project Plan of EEE-400D

We put more attention into our work in FYDP-D. Over the course of our break, we divided up the job. Shishir and Nuren finished a number of design and other solution tasks in the first week. After that, in the second week, Shakil and Jafree began the simulation of options. In week three, Nuren was conducting analysis to find the best answer. Next, we were all focused on the best solution's hardware implementation. The code and algorithms were designed by Nuren and Shakil, and Shishir and Jafree assembled the hardware. We all focused on the paperwork, draft report, and final presentation after finishing these. Everybody in engineering project management is aware that they must complete a number of jobs in various ways, which we were able to do here and finish all of the 400-D's given tasks on time.

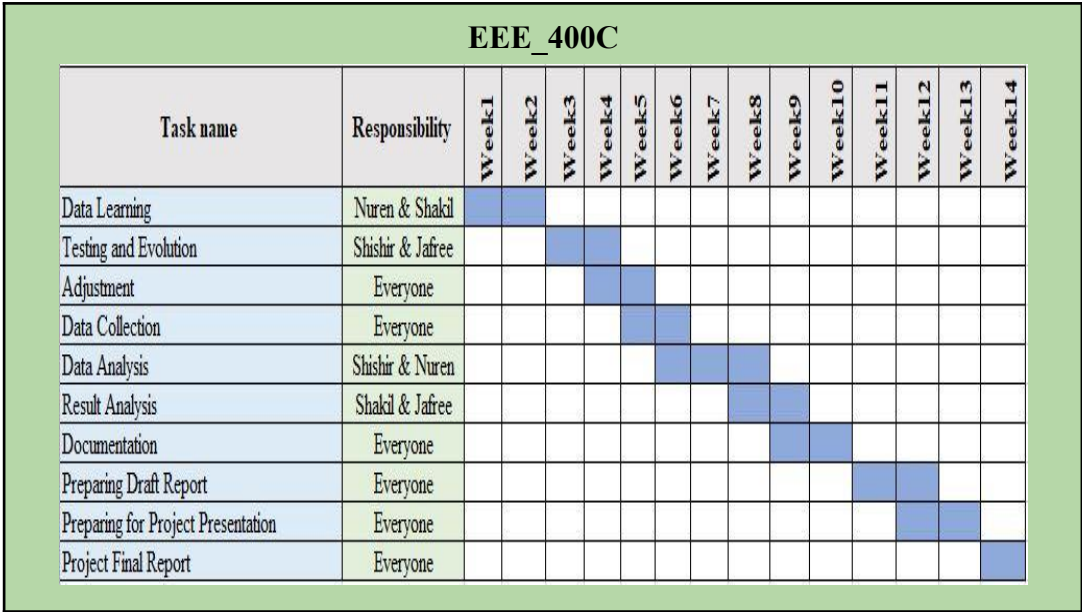


Figure37: Project Plan of EEE-400C

Shishir and Jafree spent the final two weeks of our FYDP-C concentrating on testing and evaluating the data, while Nuren and Shakil concentrated on memorizing the data. The next step involved setting up changes and data gathering, which was done by everyone. The data was also being analyzed by Shishir and Nuren, while the final product was being put together by Shakil and Jafree. All of these were completed by week ten. After the tenth week, we all worked on the last set of records, last report, and last presentation. Throughout our FYDP, we worked hard to sustain engineering management standards and did so. We worked extremely hard and did a great job planning the project, which is why it is a pearl.

**Work duration of EEE-400P**

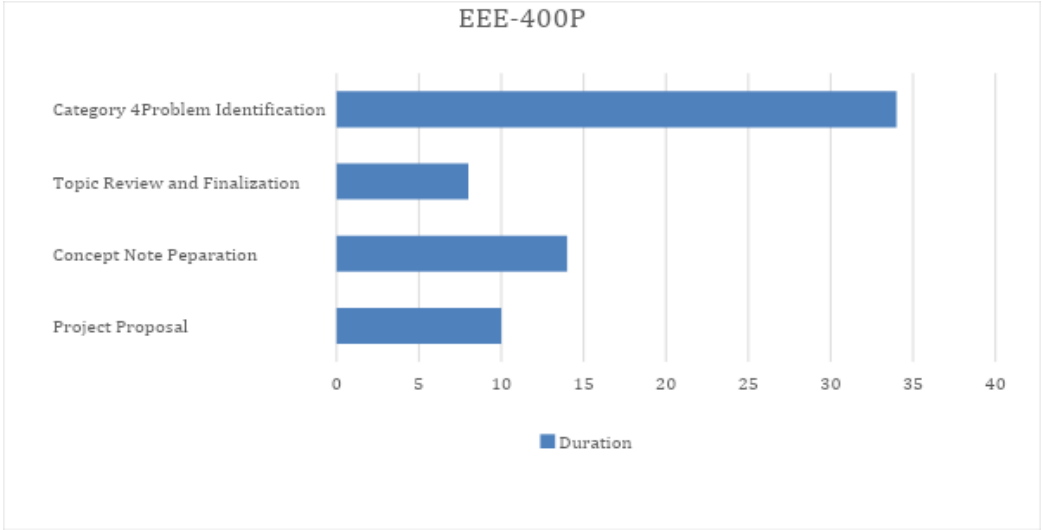


Figure38: Work duration of EEE-400P

Our project proposal took 10 days to complete and Concept Note preparation took a little bit more around 14 days, nonetheless we took less time on topic review and finalization. Category of problem identification took almost 34 days to complete because we did deep research and hard effort to complete the task.

### Work duration of EEE-400D

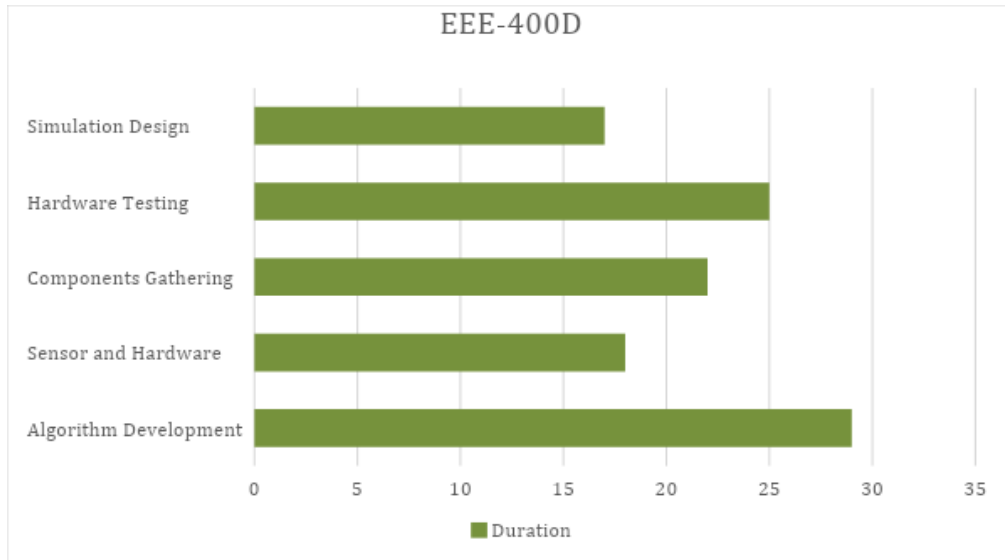


Figure39: Work duration of EEE-400D

In order to complete our project successfully, we worked for 25 days on hardware testing. Simulation Design, sensors, and hardware setup took approximately the same amount of time. Due to various unavailability issues, we spent the majority of our effort gathering the algorithmic components and 28 days developing them.

### Work duration of EEE-400C

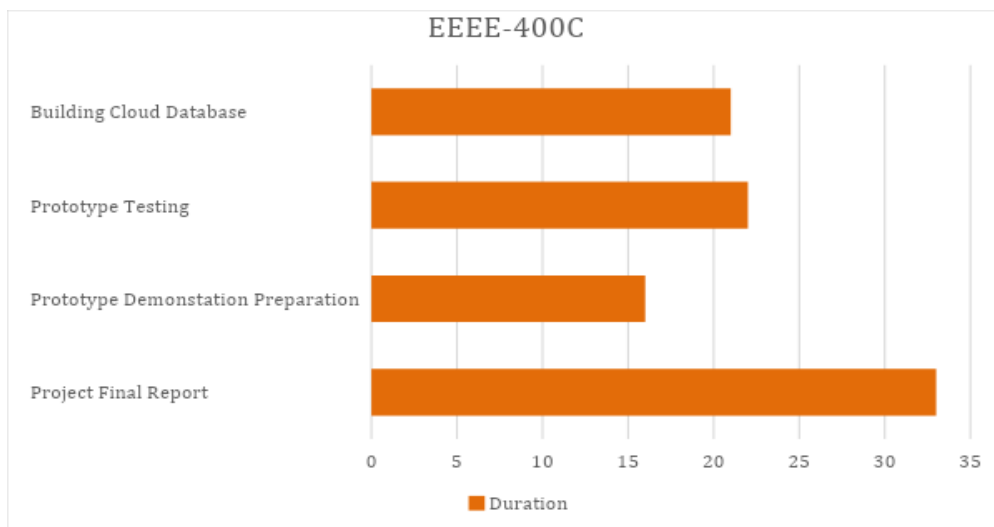


Figure40: Work duration of EEE-400C

We present our prototype in 400 C, we develop a cloud data-based system. We explored so many cloud servers that it took over 21 days to select the best cloud server for our project. In our R&D lab, we built up our prototype and tested it in various ways for 22 days. It took 34 days to complete our project in accordance with the guidelines and IEEE format, and the majority of our effort was focused here.

### **7.3 Evaluate project progress**

In January 2022, we began working on our project in accordance with our requirements. We completed every task in stages which is shown in Table 27. Following the guidance of our esteemed ATC, we formed groups and selected this project topic from a variety of research areas. We wanted to work on a project that would benefit both people and the environment simultaneously, which is unpopular in the context of our nation. We have chosen to create a system which can detect micro-organism and filter from masks. Then, in order to obtain accurate information and gain a sense of the process, we began reading various papers, articles, and journals linked to our subject. For each semester, we have created a work schedule. We evenly distributed our work among the team members and kept the logbook updated. We got to work on our project by adhering to the project plan. We had to complete our homework and other assignments online and at home because of the pandemic situation. Our regular weekly internet meetings continued. Our assignment for the first semester of the FYDP was to create the project plans. As a result, we talked about the project's design, methods, specifications, and budget. Additionally, we highlighted the sustainability, legal, and risk considerations. We began the simulation portion of our project during the following semester (400D). Here, we also provide a brief description of the other alternative solutions to our project's problems, along with a simulation of each one, and we explain why we chose ours. Due to high inflation rate the costs of most components increase rapidly and we also need to adjust the budget. Therefore, we demonstrated the significance of why and how our proposal would benefit both people and the environment. Finally, in the last semester of our project, we put the device into use and completed our monitoring successfully. Before the semester began, we began developing the hardware and software components. Then, within the first two weeks of the semester, we completed the hardware setup by assembling numerous components, including sensors, motors, and air controllers. Then we began gathering data by testing several masks from a variety of angles. We decided to carry out these tests at our R&D lab because it has the tools we need to assess the mask's condition both before and after cleaning. We first gather data from a fresh mask, then test it again after seven hours. After cleaning the mask in the disinfection chamber, we conduct another test and gather further information. Microparticle, humidity, temperature, and ozone gas data samples have all been gathered. Afterward, send the data to the cloud after viewing it on the display. We assessed the mask's condition based on those statistics. We contrasted the outcome of the sample data with the data under ideal conditions. We can determine the masks' effectiveness in this way. Based on that, we create a report on the mask's effectiveness, which is then uploaded to a cloud server and made available to anyone who needs it.



**Table27:Project plan evaluation**

Chapter	Task Title	Task Owners	Start Date	End Date	Duration	PCT OF Task Complete
Chapter No	Project Report Writing					
1	Introduction	Jafree	15/1/2022	10/2/2022	20	100%
2	Project Design Approach	Jafree	15/1/2022	15/2/2022	30	100%
3	Use of modern engineering and IT tools	Shishir	20/1/2022	25/2/2022	35	100%
4	Optimization of Multiple Design and Finding the Optimal Solution	Shishir & Nuren	5/4/2022	3/5/2022	28	100%
5	Completion of Final Design and Validation	Shishir & Nuren	5/4/2022	10/5/2022	35	100%
6	Impact analysis and Project sustainability	Nuren	15/4/2022	15/4/2022	30	100%
7	Engineering Project Management	Shishir	20/5/2022	15/6/2022	25	100%
8.	Economical Analysis	Shishir & Nuren	7/8/2022	5/9/2022	25	100%
9	Ethics and professional Responsibility	Shakil	20/6/2022	19/7/2022	30	100%
10	Conclusion and Future Work	Jafree	28/10/2022	1/12/2022	32	100%
11	Identification of Complex Engineering problems and Activities	Shishir & Nuren	1/11/2022	28/12/2022	28	100%

## **7.4 Conclusion**

The aforementioned procedures and work schedules should be followed in order to successfully execute an engineering project. Failure to do so could result in the project failing. An engineering project benefits from effective teamwork, careful planning, communication, and study. Here, we attempted to adhere to them appropriately in our project. Without effective project management, we are unable to create a work schedule, manage our time effectively, and we also run into financial difficulties. Therefore, an engineering project requires careful planning and supervision.

## Chapter 8[CO12]

### Economical Analysis

#### 8.1 Introduction

The assessment of the expenses and advantages of any project or plan is referred to as economic analysis. Any project's economic analysis calls for an estimation of the project's long-term costs and benefits. Costs cover both the initial outlay and yearly upkeep and repairs. We cannot use inexpensive tools or parts that might break down quickly or work inefficiently. Because we must secure economic viability. An economic analysis of a project attempts to make sure that it operates efficiently, and that if anyone invests in it, the country will benefit and the welfare of its citizens will improve. One of the fundamental issues in economic analysis is cost. Initial investment, yearly upkeep, and repairs are all included in the budget. All of the yearly returns that society places value on are considered benefits. Depending on a number of variables, the initial anticipated cost may go down or up when the project is actually performed. On the other hand, economic analysis also discusses the project's anticipated benefits. [24] Benefits might come in two different forms. Market benefits or non-market advantages are what they are. People are difficult to persuade of the non-market rewards. because no one can immediately gain from it. An excellent economic analysis can persuade people, increase the likelihood that the plan will be implemented successfully, and foster goodwill between the planner and the populace. It provides an overview of the entire project.

#### 8.2 Economic analysis

Economic analysis is a crucial component of the microorganism detection and filter system project in terms of evaluating the health and pandemic situation. This microorganism detection and filtration will lessen the need to purchase new masks, saving consumers' money in the process. It will also lessen the environmental damage by the disposal of used masks and other medical equipment. As humans are dependent on nature, it is our responsibility as humans to preserve the environment. The pandemic poses a hazard to people's lives. In other words, not only could people not purchase the mask, which is regarded as the primary piece of safety equipment, but there was also a possibility of a virus spreading via the worn mask. We can therefore learn how dependable and beneficial a mask is through this research effort of ours and, at the same time, we may make it useful for human use by fitting it. Our project will benefit those who don't always have the money to purchase sophisticated masks, particularly hospital and apparel workers who must be kept safe. Our economic analysis needs to be presented in a way that the average person, who may not be aware of the value of safety, can appreciate the relevance of a system for detecting and filtering microorganisms. Costs and benefits are a part of economic analysis, as we all know. Therefore, our objective is to develop the project and carry out the survey so that individuals may benefit the most from it at the lowest possible expense. However, we cannot use inexpensive tools or parts that are

inexpensive but may not last for a long time or are inefficient. Table 28 shows the cost analysis of multiple design approaches. Then, we can fall short of ensuring economic sustainability. Before utilizing or purchasing a product, we must ensure its high caliber by testing it. Every component, including the vacuum pump, power supply, and sensors, needs routine maintenance. Before it results in harm, we can determine whether a component is functioning properly or not and adjust or fix it. Additionally, it will improve the project's long-term viability. Healthcare connected technology is referred to as "Connected Care." It is described as the use of digital technologies like smartphone apps, wearable technology, secure messaging, and remote patient monitors in real-time, electronic communication between a patient and a healthcare professional.[25]

By 2025, the market for remote monitoring in the healthcare industry is predicted to be worth USD 1.1 trillion. Since they offer real-time data that enables healthcare professionals to assist patients in remote places, wearable technologies account for a sizable portion of this industry. They reduce the number of trips to the doctor's office, which offers convenience and efficiency. The market for cardiac wearables, which is predicted to be worth USD 800 billion by 2030, presents a significant opportunity for healthcare firms.[25]

The market's expansion has been impacted by and accelerated by COVID-19. Due to the nature of the epidemic and the strain it placed on health systems and infrastructure, new methods of communicating with doctors remotely have emerged as a result of the pandemic.[25]

### 8.3 Cost-benefit analysis

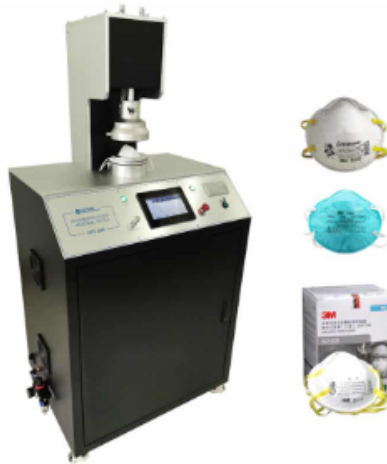
**Table 28: Cost analysis of Multiple design approaches**

Design Approach	Functionality	Component	Cost (BDTK)	Total Cost(BDTK)
Particle Filtration Using IR	<ul style="list-style-type: none"> <li>● Particle detection</li> <li>● Mounting Chamber</li> <li>● IR Chamber</li> </ul>	<ul style="list-style-type: none"> <li>● IR Sensor</li> <li>● Glass Chamber</li> <li>● IR Emitter</li> <li>● IR Detector</li> </ul>	1000 800 500 1200	3500
Particle filtration using Air Quality Indicator sensor	<ul style="list-style-type: none"> <li>● Data Collection Box</li> <li>● Air Controller</li> <li>● Glass Chamber</li> </ul>	<ul style="list-style-type: none"> <li>● DHT22</li> <li>● PMS5003</li> <li>● Vacuum pump</li> <li>● Flow-controller Valve</li> <li>● Glass Chamber</li> </ul>	330 4000 4050 940 800	10,090
IoT-based microorganism detection and filtration	<ul style="list-style-type: none"> <li>● Data Collection Box</li> <li>● Air Controller</li> <li>● Mounting Chamber</li> </ul>	<ul style="list-style-type: none"> <li>● DHT22</li> <li>● MQ-131</li> <li>● PMS7003</li> <li>● ESP D1 Mini</li> <li>● Vacuum Pump</li> <li>● Flow controller valve</li> <li>● Glass Chamber</li> </ul>	330 1500 4000 380 4050 940 200	11520

In 2021, the market for disposable face masks was estimated to be worth USD 38.9 billion. From 2022 to 2030, it is expected to rise at a CAGR of -27.6%. Due to the expanding industrial sector, disposable face masks are predicted to become more and more necessary in rising economies like China, India, and Brazil in order to guard against pollution and hazardous viruses. The COVID-19 epidemic in 2020 contributed to a sharp rise in the demand for disposable face masks around the world. The usage of these disposable face masks acts as a key infection control strategy to slow the spread of the virus. The demand for disposable face masks is also expected to increase in the near future due to the use of this product as a surgical mask to protect one from viruses and other organisms that can cause illnesses. These masks' primary function is to keep wearers away from airborne pathogens, dust, and other contaminants that might cause infections. [26] The increase in Hospital Acquired Infections (HAI) cases, the aging population, and the construction of healthcare facilities in developing economies are promoting market expansion. Despite the fact that these masks are intended to provide protection, it is advised to choose one that won't trigger any allergies. According to projections, more than 1.5 billion face masks entered the water in 2020, contributing an additional 4,680 to 6,240 metric tons of marine plastic pollution (or 5,160 to 6,880 U.S. tons). This waste is polluting our environment which will really threaten for us. Bangladesh's economy is currently not doing well. An expanded budget might not function correctly in this situation. [24] We don't want to lose any more lives in the future because of the Coronavirus. Consciously staying safe is crucial, but given the state of the economy, purchasing new masks every day would be pricey for us. To manage this, mask disinfection and filtration can be a fantastic solution. Both the general public and industries where safety precautions must be taken will benefit from it. We already discussed numerous methods for microorganism identification and filtering. Our other two methods required manual setup and were occasionally more difficult. However, those strategies are not economically viable for our nation in terms of both efficiency and cost. Market comparison of our product and competitive products is given in Table 29.

**Table 29: Market Analysis**

<b>Criteria</b>	<b>IOT based microorganism detection and filtration system</b>	<b>Mask Particle Filter Efficiency PFE Tester AFT-100</b>
<b>Functionality</b>	1. Laser particle counter 2. Particles with 0.3, 0.5, 1, 2.5, 5, 10 μm sized can be detected 3. Ozone detection 4. Filtration efficiency tester 5. PMS7003 particle counter	1. Laser particle counter 2. particle with size of 300nm—10 μm. 3. Automated Filter Material Tester and efficiency tester 4. OPC sensor (optical particle counter)
<b>Processing time</b>	90 second	30 Second
<b>Cost</b>	11520 BDT for per device	13,500-20,000 USD per device



**Figure41:Mask Particle Filter Efficiency PFE Tester AFT-100.**  
**Source:Adapted from[27]**

Wearable technologies make up a sizable component of this market because they provide real-time data that enables healthcare personnel to treat patients in distant locations. They provide convenience and efficiency by reducing the number of journeys to the doctor's office. For healthcare companies, the market for cardiac wearables, which is expected to be worth USD 800 billion by 2030, offers a substantial potential. Only particles from 300 nm-10 $\mu$ m can be measured by a laser particle counter, precise meters for flow and aerosol density control, Adjustable air volume of 20–100 liters per minute, 0–2000Pa range for measuring resistance, and up to 999% filter efficiency. PC communication, straightforward operation, and dependable performance. The price of the machine with the laser particle counter is currently between USD18,000 and USD 30,000 in China, when it was earlier between USD13,500 and USD 20,000 in Max. The main application of the AFT-100 Mask filter test machine, a type of Automated Filter Material Tester, is to assess the effectiveness of filters in self-suction particle-proof respirators as well as the effectiveness and resistance of filters in other materials[27]. Figure41 displays a photo of the AFT-100 Mask filter test machine[27]. COVID-19 has had an effect on and hastened the market's expansion. New ways of connecting with doctors remotely have emerged as a result of the pandemic due to the nature of the disease and the strain it placed on health systems and infrastructure.

IoT based microorganism detection and filtration systems will cost around 12000 per unit . If we compare it, it's near competitive. It is 100 times less . If we want to sell this in the market we have to develop the quality and it will cost around 12000 taka per unit with all maintenance costs. IOT-Based Particle Filtration is clearly the best option in this case. The cost of an IOT-based particle filtration system is lower than that of the other two varieties. For the Internet of Things, we will receive real-time data that we can store in the cloud. Our project's microbe count is more precise and efficient than others'. It has a time coefficient as well because it can filter a mask in under a minute. As the data will be stored in the cloud, this has the benefit of allowing for constant analysis and the ability to compare mask effectiveness to choose the best solution.

The segment with the highest revenue share in 2021—45.6%—was industrial application. The market is being driven by industries' increasing awareness of the value of reusing masks to shield workers from particles. Due to the expanding industrial sector and rising pollution levels, reuse face masks are becoming more and more common in developing nations like China and India. The expansion of this market is being driven by the use of disposable face masks at construction sites, mining sites, chemical firms, and by employees of paint and varnish companies. The growing awareness among users to address the rising pollution levels and the presence of hazardous microorganisms in the air is another factor contributing to the segment's rise. The market for these goods is being driven by new users who are being encouraged by growing understanding of the negative health impacts. To protect the respiratory systems, dust masks are typically worn while moving around mining or construction sites. They can be worn for shorter periods of time, providing momentary protection, while others are made to be worn continuously. The non-woven mask market is anticipated to grow between 2022 and 2030 at a CAGR (Compound annual growth rate) of -26.5%.

#### 8.4 Evaluate economic and financial aspects

**Table30: Economic and financial aspects**

Criteria	IOT based microorganism detection and filtration system	Mask Particle Filter Efficiency PFE Tester AFT-100
<b>Investment</b>	0.2 million	2 million
<b>Per device cost</b>	12000 for per device	1.4 million per device
<b>Employe cost</b>	<ul style="list-style-type: none"> <li>● 3 employe for per device</li> <li>● per employe =20,000</li> <li>● 3*20000=60,000</li> </ul>	<ul style="list-style-type: none"> <li>● 4 employe for per device</li> <li>● per employe=50,000</li> <li>● 4*50,000=2,00000</li> </ul>

People benefit greatly from IoT-based microbe detection and filtering devices. As the epidemic spreads, mask usage rises along with its price and availability rate, which puts individuals in a difficult situation. Due to a lack of interest, there were not enough people to meet the minimum requirements for safety. Reusing the mask was important to cut down on waste and protect the environment from disposal masks. However, because the available devices were expensive, there was a threat to ensuring the safety protection of reuse masks. Our project currently meets the criteria for highest efficiency at the lowest cost. From Table30 we see that the PPE testing device that is currently on the market is expensive and costs roughly 14,000 USD, which is 100 times more than ours. Because our project is more affordable, we can achieve nearly the same efficiency as currently available gadgets in the market. Considering the current global climate condition, we can not survive long if we cannot save the environment. Our research report will not only help the mask manufacturers but also help the health monitoring department. They can use the data for further research and ensuring the safety of people.

## **8.5 Conclusion**

We can infer from the reasoning above that mask reuse can reduce waste and costs. Every day, new modern technologies are developed to make people's lives easier. Due to lack of employment and inability to follow safety procedures during the epidemic, a large number of people contracted the coronavirus. If individuals began using masks again right away after sanitizing them, the fatality rate might go down. Each surgical mask cost 20 to 30 taka in Bangladesh, compared to over 2 taka during pandemics. However, following the pandemic, when the cost dropped, both the use and the wastage both increased. Therefore, our initiative will be both financially and environmentally advantageous. It is challenging to invest significantly in the renewable sector given the state of the economy in our nation. In order to achieve maximum benefits at the lowest possible cost, we therefore endeavored to create a solution. When compared to the other two alternatives, ours offers a more efficient and effective result that may also ensure the project's sustainability. It makes our project more affordable by saving time, labor, and money.



## Chapter 9[CO13, CO2]

### **Ethics and Professional Responsibilities**

#### **9.1 Introduction**

The goal of ethics is to provide people with moral and behavioral guidelines that will help them decide what is good and wrong as well as how to act and behave. Often, moral standards are higher than the bare minimum required by law. The PMI (Project Management Institute) states that "ethics is about making the best choices feasible with regard to people, resources, and the environment. Project management involves a number of potential ethical pitfalls[17] .The larger the project, the more likely it is that staff members will be willing to forgo their morals in order to complete it on schedule and under budget. As a component of scientific integrity, human rights, and partnership between science and society, ethical consideration is a significant area in project management. These ethics ensure that the research may be conducted safely. According to ethics, a project concept won't be endorsed if it violates human rights despite being beneficial to society. Depending on the situation, there are several kinds of ethical problems. The Code of Ethics and Professional Conduct lists fairness, respect, responsibility, honesty, and trust as ethical values. Along with this, other aspects of research ethics include respecting confidentiality, minimizing the risk of injury, preventing plagiarism, accuracy in analysis and reporting, etc. Additionally, there are some standards of behavior that have been established by various international organizations for specific sectors. While conducting the research, we are required to adhere to these procedures and criteria. Rejecting project proposals is another possibility if ethical standards are not upheld. Project sustainability is also guaranteed by adhering to those rules. Regarding our project, we must adhere to the government protocols, the IEEE code, and other guidelines.

#### **9.2 Identify ethical issues and professional responsibility**

One of the most crucial factors to take into account when working on any project is ethics. It is a set of beliefs and principles that should be maintained when conducting human affairs. An ethical claim can take the frame of an articulation, image or realistic on an item or bundle name, in item writing, in publicizing or in reputation, among other things. Beyond a shadow of a doubt, ethical considerations show that no one behaves in a way that is harmful to society. Moreover, whereas executing a project, ethical considerations can reduce risk, progress positive results, increment belief and construct notoriety and victory. There are some things to keep in mind when it comes to commercial production of our test setup.

1. Obviously, we will obtain authorization and sign a legal contract before installing our optimal system in any place.
2. We must substitute components for any equipment that is environmentally harmful when constructing the test setup.

3. We must include the correct cites and references if we want to include any statements or other content from these sources in our project.

4. We can't use any components, sensors and products which are declared as illegal by our government.

5. We shall be obligated to the particular one, thus the outcomes of what we obtain won't be shared with others.

6. As we implement IoT (Internet of Things) technologies into our system, these issues arise, including protection of privacy, data security, data usability, data user experience, trust, and safety [28]. Despite solving many real-world issues, these technologies also pose serious ethical and legal challenges.

### 9.3 Apply ethical issues and professional responsibility

#### Legal Consent

As our optimal solution is based on a couple of sensors as well as we are using IoT to keep our collected data in a cloud server which is not an illegal method in terms of our county's law. Moreover, we are also following the IEEE code and regulations while doing our design.

We also took approval from our department for setting up the device from R&D lab. We took permission from the Chairperson of our department and before setting up we ensured the safety. We are attaching the form below.

Date: 13<sup>th</sup> December 2022

To

The Chairperson  
Electrical and Electronic Department (EEE)  
BRAC University  
66 Mohakhali, Dhaka 1212

Subject: Prayer for approval to use the R&D lab for trail purpose

Dear Sir

I, Nuren Tahsin, on the behalf of FYDP-Group-13 would like to draw your kind attention to the fact that, we are currently doing FYDP-c and our project topic is "IoT Based Microorganism Detection and Filtration System". For functional verification and trail purpose we need to set up our device in R&D lab. For this purpose, we need your permission to access the R&D lab.

Therefore, we seek your permission to set our device in R&D lab and perform functionality testing.


Sincerely  
Nuren Tahsin  
On the behalf of group-13  
Department of Electrical and Electronics Engineering  
BRAC University

*Forwarded for consideration  
Mst  
13/12/2022*

*Mosaddeq 13.12.22*  
Dr. Md. Mosaddequr Rahman,  
Professor and Chairperson  
Electrical and Electronic Department (EEE)  
BRAC University  
66 Mohakhali, Dhaka 1212

Figure42:Approval form


Also we took public consent before collecting their mask for testing. We took their signature in consent form to maintain the protocol.

  
BRAC UNIVERSITY  
Department of Excellence

**Department of Electrical and Electronics Engineering**  
**Public Consent Form**

I agree to give my consent to the student of BRAC University (Department of Electrical and Electronics Engineering) to collect my mask for the purpose of their final year design project named IoT Based Microorganism Detection and Filtration System.

Date *12/12/2022*

  
Signature

**Figure43: Public consent form**

### **Risk Management and Contingency Plan**

While arranging and creating the thought of a project, we must be beyond any doubt the plausibility of risks since it can take out at any time and in any area and we don't have any control over it. To begin with, we ought to list a few sorts of dangers which might occur and after that analyze them, coming up with the thought of understanding the level of hazard and the elective plans. It is necessary that we all ought to be proactive rather than being responsive[29][30].

**Table 31:Risk management**

<b>Type of ricks</b>	<b>Risk Level</b> (High,Medium, Low)	<b>Ordain plan</b>	<b>Alternate plan</b>	<b>Responsible Member</b>
Technical malfunction	High	Check all components if they are working properly or not before running the system	Replace the wicked component.	Everyone
Over voltage problem	High	Check electricity connection and operating voltage	Use automatic circuit breaker	Everyone
Over current problem	High	Check the current magnitude before connecting the system	Use current transformer	
Dust Problem	Medium to Low	Set the system in Closed and clean room	Glass sealed room	Shishir and Nuren
Sensor and cloud malfunction	Medium	Check previous data and cloud access.	Change the sensor and fixed cloud	Shakil and Jafree

### **Safety Consideration**

While implementing our optimal solution, we must keep safety in mind. We need to recheck the power connection, voltage levels, current measurement properly so that it doesn't cause any bad incident in the laboratory. To prevent over voltage issues, we may also employ an automatic circuit breaker/relay.

To prevent radioactive contamination, we must eliminate all radioactive components from the laboratory. To minimize any technical issues, inspect the motor, sensors, and other components before installing the system in place.

For the purpose of gathering and analyzing data, we are using an ESP. Anyone who can manipulate the ESP can modify the data and the algorithm. Server security must be considered in order for this.

## **9.4 Conclusion**

A set of guidelines or concepts known as ethical considerations or ethics directs research or projects. For a project to succeed and to obtain the public's support, such principles must be upheld. Being responsible for your actions professionally includes abiding by those rules. We made an effort to address these ethical concerns in this project and did our best to uphold them as we conducted our research. We first group potential factors that are relevant to our project before applying them. Although some of them were eliminated from the list because they did not fit our research or project in actual experiments, others were not applied.

## Chapter 10

### Conclusion and Future Work

#### 10.1 Project summary/Conclusion

In conclusion, we would like to state that the main causes of the rising sickness rates are the rate of pollution, dust, viruses, and bacteria. To avoid contracting infections, people must use a good mask. Quality masks and safety kits might occasionally be so expensive that not everyone can afford them. New modern technologies are created daily to improve people's lives. Many persons caught the coronavirus during the epidemic as a result of unemployment and a failure to adhere to safety protocols. Therefore, we are able to examine the effectiveness of masks and provide a method to filtrate the particles. At our university's research and development lab, there is a disinfection chamber. Therefore, it was vital to repeatedly assess the effectiveness of disinfection. However, the detecting equipment that was readily accessible was extremely expensive, and the inexpensive equipment had subpar performance and low efficiency. As a result, we completed our project in a way that will allow for reuse following disinfection. After doing our test, we discovered that the safety kits or masks may be utilized again. Additionally, with the aid of our test, we keep the results and data from efficiency tests in the cloud, making them accessible and easy to evaluate. Additionally, we will be able to test a lot of masks quickly, which will be helpful for businesses and organizations. In our studies, we found that the masks' effectiveness was between 96 and 98% following disinfection when compared to brand-new and freshly worn masks. We also took ozone gas measurements. Ozone is produced by the UV after disinfection. The risk range is approximately 0.2ppm, thus we get the ozone range of 0.02ppm. The safety measure is justified by this test. Because doctors, other employees, and patients require more frequent disinfection than other groups of people, we can set up our particle filter efficiency test setup at hospitals for business purposes as well as medical facilities. Our project offers a better solution that could possibly guarantee the project's sustainability. It reduces the cost of our project by conserving time, labor, and resources.

#### 10.2 Future work

IoT technology offers enormous potential for the future in every business, but especially in the domain of data monitoring and analysis. Since our project is IoT-based, there will be a huge market for it in the future. The mask's ability to be reused can be simply verified using our equipment. We can improve the efficiency of our project by using more sophisticated machinery or by creating a more compact manufacturing design. More accurate data may be produced by assembling more effective sensors. Compact sensors were utilized because of a tight budget and consideration for Bangladesh's economic situation. However, in the future, high range PM sensors can be put together taking into account the budget to gather more nano size particles, such as those less than 0.3  $\mu\text{m}$ . Since we are aware that coronaviruses have a size of 0.1  $\mu\text{m}$ , we can detect and filter coronaviruses if we utilize a high range PM sensor.

Additionally, we may utilize machine learning to analyze data and find unattractive masks. A strong tool for data analysis, prediction, and comprehension is machine learning. It may gain knowledge from data and gradually enhance its performance. Numerous tasks, including image processing, image identification, data prediction, and natural language understanding, can be performed with it. Adding image processing is an option. We obtained the appropriate dataset from the open source website on the internet to create our image processing model. These data included 4,000 aerial photos with the proper mask data, making them ideal for training a machine learning model. First, we can segment the masks in the canopy area using a picture. The analysis of the new image in comparison to the old image is then done using that portion of the image. In this case, we use image segmentation, a sort of image processing that often separates the image into a few subgroups, for the benefit of our project. In order to enable further processing, image segmentation is a technique that separates a digital image into a few smaller groupings known as image segments. Images are segmented into more manageable groupings using pixel values. Results for segmenting images using machine learning are shown in images. The similarity-based approach identifies groups of related image pixels using a threshold. This approach to image segmentation lays the groundwork for ML methods like clustering. Finally, we can state that furthering the development and optimization of our project may be advantageous for health and safety. It will aid in defending the modern world from the microorganism threat .

## Chapter 11

### Identification of Complex Engineering Problems and Activities.

#### 11.1: Identify the attribute of complex engineering problem (EP)

There are a few properties for complex building issues. Presently, we are reaching to explain them

- **Depth of knowledge required:**To construct an appropriate building extension, we must have proper information around the significant field. Without legitimate information, we will not get an in-depth thought about a venture. Thus, to inquire about or to an extent it is obligatory to have legitimate information about almost any specific problem.
- **Range of conflicting requirements:**it implies when we begin investigating or building a venture parts of clashing issues may come. Our rationale ought to be to overcome those issues and give an arrangement in such a way that the extent will be compelling and harmless. Whereas doing ventures parts of clashing issues may come such as technical issues, lawful issues, natural issues, etc. our target will be to fathom them and provide a safe solution.
- **Depth of analysis required:**it is another essential perspective of complex engineering problems. To create a fruitful extent appropriate in-depth examination is obligatory. Without it, many issues will happen within the future that we may fall flat to fathom, consequently the project will not be useful at all.
- **Familiarity of issues:**it implies when an unused extend is planning to be executed or proposed the common individuals will not be recognizable with it. In addition, this issue may also come in terms of commonplace issues and we need to include or make something modern from the old ones.
- **Extent of applicable codes:**to make a complex engineering project there may come lots of issues related to engineering protocols. Here, we need to follow the international codes and standards to run the project. Otherwise, the project will lose its acceptance.
- **Extent of stakeholder involvement and needs:**Degree of partner involvement and needs talks approximately at the request of partners. It implies we ought to guarantee that the targeted bunch of our venture is getting benefits from our venture arrangement.
- **Interdependence:**Interdependence implies that an issue is related to another issue, hence, the issue ought to be unraveled to induce the ultimate arrangement.



Of the over traits, a few of them are utilized to our extent. They are appeared within the table below,

**Table32:Attributes of Complex Engineering Problems (EP)**

	<b>Attributes</b>	<b>Put tick (✓) as appropriate</b>	<b>Details</b>
P1	Depth of knowledge required	✓	In depth knowledge about algorithms, hardware system, software, the functionality of components is required for practical implementation of our project.
P2	Range of conflicting requirements		
P3	Depth of analysis required	✓	Formulated 3 suitable models and by a deep analysis through comparing and abstract thinking reached the optimal circuit design.
P4	Familiarity of issues	✓	Familiarity is seen in developed countries but new and additional features are presented for our country.
P5	Extent of applicable codes		
P6	Extent of stakeholder involvement and needs		
P7	Interdependence		

### **11.2: Provide reasoning how the project address selected attribute (EP)**

From the over qualities our extent has satisfied a few of them. Presently, we are clarifying those attributes.

To conduct our course, we had to go through parts of pre-research. So, ready to select the optimum arrangement that can give greatest benefits at least takes a toll. We have done the entire preparation step by step. Some time recently in the beginning of this venture we had gone through a few previous papers related to our investigation theme, which made a difference for us to urge and think about our work. From this, we too accumulate information about pertinent fields which makes a difference for us to create choices about how we can run the extent. At that point within the equipment portion before assembling the sensors, camera, and other parts of the IOT we went through different sorts of inquiries about approximately the choice of the device and the method of collecting. We have tried each of the sensors to know whether they are workable or not. We chose our gadget and its parts considering cutting edge innovation. We did not utilize any of the components which are out of the showcase and give less effectiveness. We ran through a point by point examination for each of the steps of our extension. Whereas selecting the multiple designs we have appeared the stars and cons of each of the arrangements briefly. which made a difference for us to choose the leading one

from them. Within the computer program area, we have analyzed the sensor information briefly in such a way that can donate clear yield approximately the effectiveness of cover. We showed all the point by point about our information investigation that can appear the right result of our inquiry about. So, the Profundity of examination required for our venture has been effectively set up. The attribute of clashing necessities has appeared in our extent whereas doing the different plan analysis. We had chosen three conceivable arrangements for our observing framework. At that point analyze each of them and discover which is satisfying our craved prerequisite more effectively and successfully. All of them have a few positive sides and some negative sides. We sorted them down and found the optimum one which can fulfill our prerequisites to induce the required yield.

### 11.3 Identify the attribute of complex engineering activities (EA)

The properties of complex building activities(EA) are portrayed underneath.

- **Range of resources:**The run of assets incorporates components that are necessary for fruitful extended execution. Individuals, gear, cash, time, knowledge, and anything that's required from the venture arranging to the venture conveyance phases are beneath the assets.
- **Level of interaction:**it incorporates all sorts of communication and interaction with the people related to extended subjects such as professionals, engineers, partners, even communication inside the group, etc.
- **Innovation:**Development is another viewpoint of a building venture as able to invent something unused from our investigate project which will be accommodating for others. Thus, the solution should be advantageous for the focused on bunch and it ought to give a proper level of productivity.
- **Consequences for society and the environment:**A complex designing extent must have a few results related to the environment and society. This property talks about it. We got to discover them and fathom them in any conceivable way.
- **Familiarity:**Whereas doing inquire about a subject or doing a venture parcels of things may come up which are too unused to us which may make the venture troublesome to get it. In this case, we got to unravel them with legitimate inquiry and cooperation.

Among these traits three of them are connected in our extend, they are appeared within the box below,

**Table33:Attribute of complex engineering activities (EA)**

	Attributes	Put tick (✓) as appropriate	Details
A1	Range of resource	✓	Our project met a diverse range of resources. Like, so many literature reviews for gathering knowledge on information and technology, worked according to our plan, we had discussion on confirming the components and for budget selection etc.
A2	Level of interaction	✓	Proper suggestion and interaction with ATC members and follow their guideline
A3	Innovation		
A4	Consequences for society and the environment	✓	Will reduce environmental burden as well as cost efficient devices can reduce economic burden .
A5	Familiarity		

#### **11.4 Provide reasoning how the project address selected attribute (EA)**

Our extent required a bounty of assets in each step—from arranging to execution we had to use different sorts of assets depending on the venture prerequisite. Extended assets are components that are essential for fruitful extended execution. They incorporate people, equipment, cash, time, information, and anything that's required from the venture planning to the extended delivery phases. From the primary semester of our last year plan, we have gone through parts of articles, papers, and diaries that are significant to our extent. Those are also a portion of assets. At that point we utilized different computer programs like c programming . At last, for hardware implementation, we assembled the sensors, and cameras and arranged the complete gadget by ourselves. We had to plan the budget and work in a similar manner. That was too much of a resource. We talked about with our ATC for his recommendation and examined among ourselves and shared our thoughts which made a difference for us to encourage choices and to create a fruitful venture. So, it can be said that a wide run of assets has been utilized to total the complete extent successfully. Process intelligence can be in a few distinctive shapes in which the fundamental venture management processes, such as starting, arranging, executing, checking, and controlling, as well as closing, can interact with each other amid conducting venture exercises. All of our group members associated with each other and shared our considerations and concepts. We kept up our weekly gatherings and satisfied our week by week errands carefully. We have regarded each other's opinions and examined them among ourselves conjointly to get exhortation from our honorable ATC. A good level of interaction is required for a venture to be effective. from the determination of project topics to the execution of our venture all of us shared our thoughts. and after talking, we selected the ultimate choices. In this way, we have completed our venture.

## References

- [1] I. S. Jacobs and C. P. Bean, "Fine particles, thin films and exchange anisotropy," in *Magnetism*, vol. III, G. T. Rado and H. Suhl, Eds. New York: Academic, 1963, pp. 271–350.
- [2] Cuffari, B. (2021, February 15). The size of SARS-COV-2 and its implications. News. Retrieved March 6, 2022, from <https://www.news-medical.net/health/The-Size-of-SARS-CoV-2-Compared-to-Other-Things.aspx>
- [3] Radonovich, L. J., Perl, T. M., Davey, V. & Cohen, H. Preventing the soldiers of health care from becoming victims on the pandemic battlefield: Respirators or surgical masks as the armor of choice. *Disaster Med. Public Health Prep.* 3, S203–S210 (2009)
- [4] Forouzandeh, P.; O’Dowd, K.; Pillai, S.C. Face masks and respirators in the fight against the COVID-19 pandemic: An overview of the standards and testing methods. *Saf. Sci.* 2020, 133, 104995.
- [5] O’Dowd, K.; Nair, K.M.; Forouzandeh, P.; Mathew, S.; Grant, J.; Moran, R.; Bartlett, J.; Bird, J.; Pillai, S.C. Face masks and respirators in the fight against the COVID-19 pandemic: A review of current materials, advances and future perspectives. *Materials* 2020, 13, 3363.
- [6] Forouzandeh, P.; O’Dowd, K.; Pillai, S.C. Face masks and respirators in the fight against the COVID-19 pandemic: An overview of the standards and testing methods. *Saf. Sci.* 2020, 133, 104995
- [7] "IEEE standard for sensor performance parameter definitions", in IEEE std P2413/D0.4.6, pp.1-653 March 2019, Ics code:31.220.01
- [8] IEEE standards activities in the internet of things (IOT ... (n.d.). Retrieved March 11, 2022, from <https://standards.ieee.org/wp-content/uploads/import/documents/other/iot.pdf>
- [9] Tsbmail. (n.d.). Y.2060 Overview of the internet of things. Retrieved March 11, 2022, from <https://www.itu.int/rec/T-REC-Y.2060-201206-I/en>
- [10] Masks, understand it through standards. Masks, understand it through standards-Laianzhi Home - FFP2 FFP3 Respirators CE EN149:2001 FFP2 FFP3 Mask KN95 KN100 GB2626 Particulate Masks Medical Surgical Masks Manufactory. (n.d.). Retrieved March 11, 2022, from <https://www.laianzhi.org/news/3.html#:~:text=GB%202626-2006%20%22Respiratory%20Protective%20Equipment%20Self-priming%20Filter-type%20AntiParticulate,text%20and%20was%20implemented%20on%20December%20201%2C%202006>
- [11] Das, S., Hossain, E., Bhadra, S., Jain, H., Bhattacharya, A. and Ghosh, S., 2020. *A low-cost, compact, open-source, face mask particle filtration efficiency test setup*. 1st ed. [ebook] Mumbai, India: Tata Institute of Fundamental Research, p.7. Available at: <[https://github.com/shescitech/TIFR\\_Mask\\_Efficiency/blob/master/TIFR\\_Mask\\_Tester\\_08Aug20.pdf?fbclid=IwAR2k30iJ893rcDlBg3VeQbJp0H0V9KwzXaMi5dOgxJXPxm-oL8ANcTsYyug](https://github.com/shescitech/TIFR_Mask_Efficiency/blob/master/TIFR_Mask_Tester_08Aug20.pdf?fbclid=IwAR2k30iJ893rcDlBg3VeQbJp0H0V9KwzXaMi5dOgxJXPxm-oL8ANcTsYyug)> [Accessed 8 August 2020].

[12] K. (2017, September 17). The 3 Types of Particle Detectors: How We See the Invisible. Kaiterra. Retrieved March 6, 2022, from

[13] ThingSpeak. (n.d.). Halvorsen.Blog. Retrieved December 21, 2022, from <https://www.halvorsen.blog/documents/technology/iot/thingspeak/thingspeak.php>

[14] V., C. (2021, August 11). Tinkercad: The online software to start 3D modeling. 3Dnatives. Retrieved September 3, 2022, from <https://www.3dnatives.com/en/tinkercad-all-you-need-to-know-120320204/#!>

[15] What is Blynk? (2020, October 12). Tech Explorations. <https://techexplorations.com/guides/blynk/1-what-is-blynk/>

[16] [S. Zhou Shi Jaji Cheng Hua Wang. Construction and practice of virtual simulation experimental teaching center, [J]. Computer Teaching, 2015 (9): 5-11].

[17] [“Comparison of the advantages and disadvantages of several mainstream electronic circuit simulation software” Available at <https://blog.actorsfit.com/a?ID=01000-202df8c1-9544-43dd-bdc2-844e64c1d201>]

[18] (N.d.). Espruino.com. Retrieved December 21, 2022, from <https://www.espruino.com/datasheets/PMS7003.pdf>

[19] (PDF) MQ131 Datasheet - Semiconductor Sensor for Ozone. (n.d.). Datasheet.Es. Retrieved December 21, 2022, from <http://www.datasheet.es/PDF/770516/MQ131-pdf.html>

[20] A. Dziuba, “Internet of things (IOT) testing: Why is it so important?,” Relevant Software, 29-Nov-2021. [Online]. Available:

<https://relevant.software/blog/iot-testing-importance/>

[21] Hindawi. (n.d.). Evaluation of low-cost sensors for ambient PM2.5 monitoring. Evaluation of Low-Cost Sensors for Ambient PM2.5 Monitoring. Retrieved September 9, 2022, from <https://www.hindawi.com/journals/js/2018/5096540/#abstract>

[22] RF Wireless World. Advantages and Disadvantages of Infrared sensor. (n.d.). Retrieved September 9, 2022, from <https://www.rfwireless-world.com/Terminology/Advantages-and-Disadvantages-of-Infrared-Sensor.html>

[23] Narayana Health. (2020, April 6). Know about proper usage, disposal and reuse of mask. Narayana Health Care.

<https://www.narayanahealth.org/blog/know-about-proper-usage-disposal-and-reuse-of-mask/>

[24] Malin, Z. (2021, April 21). *How to reduce face mask pollution, according to experts.* NBC News. <https://www.nbcnews.com/select/shopping/eco-friendly-face-mask-ncna1264810>

[25] Chhatwal, G. (2022, May 4). The Importance of IoT for Brands and Market Research. Kadence.

<https://kadence.com/the-importance-of-iot-for-brands-and-market-research/>

[26] Narayana Health. (2020, April 6). *Know about proper usage, disposal and reuse of mask.*

NarayanaHealthCare. <https://www.narayanahealth.org/blog/know-about-proper-usage-disposal-and-reuse-of-mask/>

[27] Hefei Fanyuan Instrument Co., Ltd. (2022, November 29). Mask Particle Filter Efficiency PFE Tester with affordable price from FYI. FYI Tester. <https://fyitester.com/for-sale/mask-pfe-tester/>

[28] Joshi, M., Khan, A., & Sapra, B. (2020). Quick laboratory methodology for determining the particle filtration efficiency of face masks/respirators in the wake of COVID-19 pandemic. *Journal of Industrial Textiles*, 152808372097508.

<https://doi.org/10.1177/1528083720975084>

[29] A. Idries, N. Mohamed, I. Jawhar, F. Mohamed, and J. Al-Jaroodi, “Challenges of developing UAV

[30] Schweriner, J. H. (2007). Ethics considerations for the project manager in professional services. Paper presented at PMI® Global Congress 2007—EMEA, Budapest, Hungary. Newtown Square, PA: Project Management Institute.

[31] Karentz, D. (2008). Ozone Layer. In *Encyclopedia of Ecology* (pp. 2615–2621). Elsevier.

## Logbook

**Table 34: Team logbook -400P**

Date/Time/Place	Attendee	Summary of Meeting Minutes	Responsible	Comment by ATC
10/2/22	ATC Meeting	Discussion about topics that we choose.	All	Find more idea
11/2/22	1.Shishir 2.Shakil 3.Jafree 4.Nuren	Discussion on everyone's gathered idea and initially choosing a few topics	All	.
13/2/22	ATC Meeting	Finalized topic	All	Suggested to find some relevant papers
17/2/22	1.Shishir 2.Shakil 3.Jafree 4.Nuren	Finding objective, multiple design approaches, specification and requirements	Task1: Objective and multiple design approach: Nuren, Shishir, Jafree Task2: Specification and Requirements: Shakil, Nuren	
20/2/22	1.Shishir 2.Shakil 3.Jafree 4.Nuren	Prepared draft copy of Concept note on "IoT based micro particle Detection and filtration efficiency monitoring system"	All	
21/2/22	ATC Meeting	Discussion on the proposed Idea and findings	Nuren, Shishir	Make changes on design approach
22/2/22	1.Shishir 2.Nuren	Finding multiple design approaches	Shishir, Nuren	
24/2/22	ATC meeting	Discussion on multiple design approach	Shishir, Nuren	Suggested to go through more paper
26/2/22	1.Shishir 2.Shakil 3.Jafree 4.Nuren	Made changes on specification and requirements and finding constrain	All	
28/2/22	1.Shishir 2.Nuren	Discussed about functional and non-functional requirements	Shishir, Nuren	Need to correct specification and requirements
4/3/22	1.Shishir 2.Shakil 3.Jafree 4.Nuren	Preparing "Draft Copy of concept note"	Task1: Literature Review: Jafree	
7/3/22	ATC Meeting (offline)	Discussion on detailed report	Shishir, Nuren	Need to change System level diagram
8/3/22	1.Shishir 2.Shakil 3.Jafree 4.Nuren	Preparing slides for presentation 1	All	

14/3/22	1.Shishir 2.Shakil 3.Jafree 4.Nuren	Making final copy of concept note	All	
15/3/22				
16/3/22				
20/3/22	1.Shishir 2.Nuren	Worked on Gantt chart,component details,ethical consideration	Task1 :Component details: Nuren Task2:Gantt chart,Ethical consideration :Shishir	
21/3/22	ATC Meeting	Gave update about gantt chart ,ethical consideration	Shishir	Advised to complete further work
25/3/22	ATC Meeting (offline)	Getting sensor PM2.5 and ESP	Shishir,Nuren	Advised to finalize components
28/3/22	ATC Meeting	Discussion on choosing the components and preparing the plan	Shishir,Nuren,Jafree	Recommended to do more study on specifications and prepare component level flowchart
3/4/22	1.Shishir 2.Shakil 3.Jafree 4.Nuren	Analyzing specifications and component level flowchart	Task1 ;Specification :Nuren Task2:Component level flowchart:Shishir	
4/4/22	ATC Meeting (offline)	Showed component level flowchart	Shishir,Nuren	Advised to make correction on flowchart
11/4/22	1.Shishir 2.Shakil 3.Jafree 4.Nuren	Worked on Sustainability, Risk Management and Analysis, Safety Consideration	Task1 : Sustainability: Jafree Task2: Risk Management and Analysis:Shishir Task3: Safety Consideration:Nuren	
11/4/22	ATC Meeting	Discussed about alternative components	Nuren , Shishir	Advised to go through more papers
13/4/22	1.Shishir 2.Nuren	Worked on Budget	Shishir,Nuren	
14/4/22	ATC Meeting (offline)	Showed budget and details	Shishir,Nuren	Advised to work on final proposal
16/4/22	1.Shishir 2.Nuren	Making “Progress presentation 2” slides	Shishir,Nuren	
17/4/22				
18/4/22	ATC Meeting (offline)	Discussion on overall Project and slide	Shishir,Nuren	Advised to modify slide
25/4/22	ATC Meeting	Giving mock presentation	All	Advised to make some changes on slide and add sustainability matrix
27/4/22	1.Shishir 2.Shakil 3.Jafree 4.Nuren	Giving final touch on report and slide before presentation	All	



**Table 35: Team logbook -400D**

Date/Time/Place	Attendee	Summary of Meeting Minutes	Responsible	Comment by ATC
13/6/22	ATC Meeting	Discussion about the simulation of multiple designs that we choose.	All	Find more idea
17/6/22	1.Shishir 2.Shakil 3.Jafree 4.Nuren	Simulation of design1 and 2	All	.
20/6/22	ATC Meeting	Simulation showed	All	Suggested to change the approach
25/6/22	1.Shishir 2.Jafree 3.Nuren	Simulation of all 3 design approaches with individual sensors	Design1-Shishir,Jafree Design2,3-Nuren	
27/6/22	ATC meeting	Showed Simulation of 3 designs	Nuren,Shakil	Suggested to connects the sensors properly and build a cloud server
28/6/22	ATC Meeting	Showed slide for progress presentation	Nuren,Shishir	Make changes on based on suggestion
29/6/22	1.Shishir 2.Nuren 3.Jafree 4.Shakil	Taking preparation of progress presentation	All	
18/7/22	ATC meeting	Showed final simulation of 3 designs	Shishir,Nuren,Jafree, Shakil	Approval of simulation
23/7/22	1.Shishir 2.Jafree 3.Nuren	Started working with hardware parts	Shishir,Nuren,Jafree	
25/7/22	ATC meeting	Showed hardware connecting	Shishir,Nuren	Try to store data in cloud server
5/8/22	1.Shishir 2.Jafree 3.Nuren	Storing data in cloud server and working with pms sensor	Nuren,Shishir,jafree	Taking pms sensor data with arduino
8/8/22	ATC Meeting	Showed PMS sensor data	Shishir,Nuren	Modify the code using data sheet
19/8/22	1.Shishir 2.Shakil 3.Jafree 4.Nuren	Preparing slides for final presentation	All	
20/8/22	1.Shishir	Making final report	All	
21/8/22	2.Shakil			
22/8/22	3.Jafree 4.Nuren			
22/8/22	ATC meeting	Showed final presentation slide	Nuren ,Jafree	Suggested to modify
26/8/22	ATC Meeting	Showed updated slide	Nuren,Jafree	Suggested to add video
1/9/22	1Nuren 2.Jafree	Final report preparing		

**Table 36: Team logbook -400C**

<b>Date/Time/Place</b>	<b>Attendee</b>	<b>Summary of Meeting Minutes</b>	<b>Responsible</b>	<b>Comment by ATC</b>
5/10/22	ATC Meeting	Discussed about the progress of hardware implementation	Nuren, Shishir	Complete hardware and show data
10/10/22- 15/10/22	1.Nuren 2.Shishi 3.Jafree	Completing sensor synchronization	Shishir,Jafree, Nuren	
19/10/22	ATC meeting	Showed progress and data	Nuren,Shishir	Suggested to show the data in one graph
29/10/22	1.Shishir 2.Nuren 3.Jafree	Taking preparation of progress presentation And making slides	All	
2/11/22	ATC meeting	Showed findings, graph, video demonstration and slide	Shishir,Nuren	Approval of findings and slide
16/11/22	ATC meeting	Discussed about PCB design and final hardware design	Shishir,Nuren	Suggested to do PCB design
24/11/22- 26/11/22	1.Shishir 2.Jafree 3.Nuren	Working on mask efficiency and synthesizing code	Shishir,Jafree, Nuren	
7/12/22	ATC meeting	Showed data and findings	Nuren,Shishir	Suggested to modify

11/12/22	ATC Meeting (with Mohsin sir)	Showed updated data, final design, slide	Nuren, Shishir	Approval of data
14/12/22	ATC Meeting	Mock presentation	All	Suggested to change some points on slide
18/12/22- 21/12/22	1. Nuren 2. Shishir	Report preparation and submission	Nuren, Shishir	

## Appendix

### Related code/theory

```
#include <SoftwareSerial.h>
#include <LiquidCrystal.h>
#include <DHT.h>
#include <DHT_U.h>
#include <Adafruit_PM25AQI.h>
#include <Adafruit_Sensor.h>
#include <MQ131.h>

//Wifi Credentials
String ssid = "N.T M.S.F_5G";
String pass = "01558228782";

//Particles Refferences Values
#define m03 200
#define m05 180
#define m10 150
#define m25 130
#define m50 120
#define m100 100

#define DHTPIN 2
#define DHTTYPE DHT22
#define GaPin A4
#define GdPin 13
#define button A2

DHT_Unified dht(DHTPIN, DHTTYPE);
Adafruit_PM25AQI aqi = Adafruit_PM25AQI();
LiquidCrystal lcd(12, 11, 10, 9, 8, 7);
SoftwareSerial pms(6, 5);
SoftwareSerial wifi(4, 3);

sensors_event_t event;
PM25_AQI_Data data;

byte temp, humidity;
int pm03, pm05, pm10, pm25, pm50, pm100;
float ozone;
long prev;
int efficiency1, efficiency2;
```

```

void setup() {
  Serial.begin(9600);
  dht.begin();
  wifi.begin(9600);
  pms.begin(9600);
  lcd.begin(20, 4);
  pinMode(button, INPUT);

  wifi.println("WIFI=" + ssid + "," + pass + "$");
  delay(1000);
  wifi.println("WIFI=" + ssid + "," + pass + "$");
  delay(1000);

  //MQ131 Callibration
  lcd.print("Calibrating MQ131...");
  lcd.setCursor(0, 1);
  lcd.print("Please wait...");
  MQ131.begin(GdPin, GaPin, LOW_CONCENTRATION, 1000000);
  MQ131.calibrate();

  //DHT22 Callibration
  sensor_t sensor;
  dht.temperature().getSensor(&sensor);
  dht.humidity().getSensor(&sensor);

  //PMS7003 Callibration
  if (!aqi.begin_UART(&pms)) {
    lcd.clear();
    lcd.print("PM2.5 Error!");
    while (1) delay(10);
  }
  lcd.clear();
  lcd.print("PM2.5 OK..");
  delay(1000);
  lcd.clear();
}

void loop() {
  lcd.setCursor(0, 0);
  lcd.print("Mask Efficiency Test");
  lcd.setCursor(0, 2);
  lcd.print(" Plz Press To Start ");
}

```

```

if (!digitalRead(button)) {
    Test("1", efficiency1);
    lcd.print("Press For Test-2");
    while (digitalRead(button));
    Test("2", efficiency2);

    lcd.setCursor(0, 1);
    lcd.print((String) "Mask-1: " + efficiency1 + " %" );
    lcd.setCursor(0, 2);
    lcd.print((String) "Mask-2: " + efficiency2 + " %" );
    while (digitalRead(button));
    delay(500);
    lcd.clear();
}
delay(100);
}

```

```

void Test(String test, int &efficiency) {
    lcd.clear();
    lcd.setCursor(0, 0);
    lcd.print("    TEST-" + test + "    ");
    lcd.setCursor(0, 2);
    lcd.print("  Plz Set Mask-" + test + "  ");
    delay(1000);

```

```

    lcd.clear();
    getTemp();
    getOzone();
    getParticle();
    calculation(efficiency);

    sendData(test, efficiency);
    result(efficiency);
    delay(5000);
    lcd.clear();
}

```

```

void getTemp() {
    dht.temperature().getEvent(&event);
    if (isnan(event.temperature));
    else temp = event.temperature;
    dht.humidity().getEvent(&event);

```

```

if (isnan(event.relative_humidity));
else humidity = event.relative_humidity;

lcd.setCursor(0, 0);
lcd.print((String)"T:" + temp + (char)223 + "C");
lcd.print((String)" H:" + humidity + "% O: ?");
}

void getOzone() {
  MQ131.sample();
  ozone = MQ131.getO3(PPM);
  lcd.setCursor(15, 0);
  lcd.print(ozone);
}

void getParticle() {
  PM25_AQI_Data data;
  if (aqi.read(&data)) {
    pm03 = data.particles_03um;
    pm05 = data.particles_05um;
    pm10 = data.particles_10um;
    pm25 = data.particles_25um;
    pm50 = data.particles_50um;
    pm100 = data.particles_100um;
    delay(1000);
    pm03 = data.particles_03um;
    pm05 = data.particles_05um;
    pm10 = data.particles_10um;
    pm25 = data.particles_25um;
    pm50 = data.particles_50um;
    pm100 = data.particles_100um;
    delay(1000);
    pm03 = data.particles_03um;
    pm05 = data.particles_05um;
    pm10 = data.particles_10um;
    pm25 = data.particles_25um;
    pm50 = data.particles_50um;
    pm100 = data.particles_100um;
  }

  lcd.setCursor(0, 1);
  lcd.print((String)"3: " + pm03 + " 10: " + pm10 + " ");
  lcd.setCursor(0, 2);

```

```
    lcd.print((String) "25:" + pm25 + " 50:" + pm50 + " 100:" + pm100 + " ");
}
```

```
void calculation(int &efficiency) {
    pm03 = 1-(pm03/m03);
    pm03 = map(pm03, 0, 800, 100, 0);
    pm03 = constrain(pm03, 0, 100);
```

```
    pm05 = 1-(pm05/m05);
    pm05 = map(pm05, 0, 800, 100, 0);
    pm05 = constrain(pm05, 0, 100);
```

```
    pm10 = 1-(pm10/ m10);
    pm10 = map(pm10, 0, 800, 100, 0);
    pm10 = constrain(pm10, 0, 100);
```

```
    pm25 = 1-(pm25/m25);
    pm25 = map(pm25, 0, 800, 100, 0);
    pm25 = constrain(pm25, 0, 100);
```

```
    pm50 =1-(pm50/m50);
    pm50 = map(pm50, 0, 800, 100, 0);
    pm50 = constrain(pm50, 0, 100);
```

```
    pm100 = 1-(pm100/m100);
    pm100 = map(pm100, 0, 800, 100, 0);
    pm100 = constrain(pm100, 0, 100);
```

```
    efficiency = (pm03 + pm05 + pm10 + pm25 + pm50 + pm100) / 6;
}
```

```
void result(int &efficiency) {
    lcd.setCursor(0, 3);
    lcd.print((String)"Efficieny: " + efficiency + " %");
}
```

```
void sendData(String test, int &efficiency) {
    wifi.println((String) "VAL" + test + "=" + pm03 + ","
        + pm05 + ","
        + pm10 + ","
        + pm25 + ","
        + pm50 + ","
        + pm100 + ",");
}
```



```
+ efficiency + ","  
+ humidity + ","  
+ temp + ","  
+ ozone + ",");  
}
```