

# IoT Based Automated Entry System with Integration of Covid-19 Symptom Detection

By

Rubaiyat Alam Ruhin

18121067

Aminul Islam

18121007

Tahsin Muhtady Mahi

18121005

A Final Year Design Project (FYDP) submitted to the Department of Electrical and Electronic Engineering in partial fulfillment of the requirements for the degree of Bachelor of Science

Electrical and Electronic Engineering  
Brac University  
January, 2022

# IoT Based Automated Entry System with Integration of Covid-19 Symptom Detection

By

Rubaiyat Alam Ruhin

18121067

Aminul Islam

18121007

Tahsin Muhtady Mahi

18121005

A Final Year Design Project (FYDP) submitted to the Department of Electrical and Electronic Engineering in partial fulfillment of the requirements for the degree of Bachelor of Science

## **Academic Technical Committee (ATC) Panel Member:**

Dr. Abu S.M. Mohsin (Chair)

Associate Professor, Department of EEE, BRAC University

Tayeb Hasan Sakib (Member)

Lecturer, Department of EEE, BRAC University

Electrical and Electronic Engineering

Brac University

Januray, 2022

© 2022. Brac University

All rights reserved.

## **Declaration**

It is hereby declared that

1. The Final Year Design Project (FYDP) submitted is my/our own original work while completing degree at Brac University.
2. The Final Year Design Project (FYDP) does not contain material previously published or written by a third party, except where this is appropriately cited through full and accurate referencing.
3. The Final Year Design Project (FYDP) does not contain material which has been accepted, or submitted, for any other degree or diploma at a university or other institution.
4. I/We have acknowledged all main sources of help.

**Student's Full Name & Signature:**

---

**Rubaiyat Alam Ruhin**  
**18121067**

---

**Aminul Islam**  
**18121007**

---

**Tahsin Muhtady Mahi**  
**18121005**

## Approval

The Final Year Design Project (FYDP) titled “IoT Based Automated Entry System with Integration of Covid-19 Symptom Detection” is submitted by

1. Rubaiyat Alam Ruhin (18121067)
2. Aminul Islam (18121007)
3. Tahsin Muhtady Mahi (18121005)

of Spring, 2018 has been accepted as satisfactory in partial fulfillment of the requirement for the degree of Bachelor of Science in Electrical and Electronics Engineering on 6th January, 2022.

### Examining Committee:

Academic Technical  
Committee (ATC):  
(Chair)

---

Abu S.M. Mohsin, PhD  
Associate Professor, Department of Electrical and Electronics  
Engineering  
BRAC University

Final Year Design Project  
Coordination Committee:  
(Chair)

---

Abu S.M. Mohsin, PhD  
Associate Professor, Department of Electrical and Electronics  
Engineering  
BRAC University

Department Chair:

---

Md. Mosaddequr Rahman, PhD  
Professor and Chairperson, Department of Electrical and  
Electronics Engineering  
BRAC University

## **Ethics Statement**

It is to believe strongly that the overall project report done by all the group members have been monitored and made sure that the report has satisfied all the ethical considerations for writing a fruitful and efficient project report as well as the experimental data that had been implied on this report are taken from legit data measurements. A slight match with any other relevant report compared to this one is to be considered as a total Coincidence.

## **Abstract/ Executive Summary**

COVID-19 has stopped the normal life since December 2019. We still cannot go out without worrying about getting infected by this deadly virus. Although offices and other work places have started to open, they have to maintain a health protocol set by WHO (World Health Organization). The main reason for this outbreak is the irresponsibility of the people and the authorities regarding maintaining the health protocols. As people do not maintain the health protocols properly, the safety in a work environment is breached and the virus starts to spread. After extended period of lockdown, the world is again returning to its old state by gradually opening the educational institutions and offices. So, to maintain the health protocol with notable integrity, the development of an Internet of Things (IoT)-based Automated Entry System with COVID-19 Symptom Detection is an attempt to reduce COVID-19's spread through making aware people of their conditions. This is accomplished by first developing an RFID-based entry and log data base, then employing a machine learning model to recognize face masks so that the device can detect unauthorized intruder and distinguish between mask and non-mask users. After that the non-contact temperature sensor and an oximeter sensor will take physical data to cross check with COVID-19 symptoms. This way the device can determine the risk factor of being a COVID-19 virus carrier.

**Keywords:** IoT, Entry System, Machine Learning, Face-mask, Symptom Detection, COVID-19.

## **Acknowledgement**

The authors would like to acknowledge “Dr. Abu S.M. Mohsin, Assistant Professor, Department of Electrical and Electronics Engineering, BRAC University” for the invaluable guidance throughout the developing period of this project and for the support to successfully complete this project.

## Table Of Content

Chapter 1: Introduction .....	1
Chapter 2: Project Design Approach .....	7
Chapter 3: Use of Modern Engineering and IT Tool.....	18
Chapter 4: Optimization of Multiple Design and Finding the Optimal Solution. ....	23
Chapter 5: Completion of Final Design and Validation. ....	30
Chapter 6: Impact Analysis and Project Sustainability.....	37
Chapter 7: Engineering Project Management.....	41
Chapter 8: Economical Analysis.....	49
Chapter 9: Ethics and Professional Responsibilities.....	54
Chapter 10: Conclusion and Future Work.....	56
Chapter 11: Identification of Complex Engineering Problems and Activities.....	57
Attributes of Complex Engineering Problems (EP).....	61
Attributes of Complex Engineering Activities (EA) .....	61
References.....	62
Appendix.....	63



## **List of Acronyms**

WHO	World Health Organization
CNN	Convolutional Neural Networks
RFID	Radio-frequency identification
ADC	Analog-digital converter
DSP	Digital Signal Processing
CUDA	Compute Unified Device Architecture
UID	Unique Identification
I2C	Inter-Integrated Circuit
UV	Ultraviolet

## **Chapter 1: Introduction**

### **1.1 Introduction**

#### **1.1.1 Problem Statement**

COVID-19 has stopped the normal life since December 2019. We still cannot go out without worrying about getting infected by this deadly virus. Although offices and other work places have started to open, they have to maintain a health protocol set by WHO (World Health Organization). Even the educational institutes have not yet opened properly. Recently after the Omicron variant outbreak, some of the European countries have gone back into lockdown. The main reason for this outbreak is the irresponsibility of the people and the authorities regarding maintaining the health protocols. As people do not maintain the health protocols properly, the safety in a work environment is breached and the virus starts to spread.

#### **1.1.2 Background Study**

We have been fighting the virus called COVID-19 for over two years now. We have adapted ourselves with this virus, moreover we are learning newer ways to fight this virus. We cannot separate this pandemic from our lives since it has become a part of our lives. Modern technologies have offered numerous solutions to adapt with COVID-19. People now have to maintain a health protocol set by WHO (World Health Organization) when they are entering any premises to stop the virus from spreading. The authorities now check if the people entering the building or campuses whether the people entering are wearing a mask or not, are their temperature normal or not. But according to studies, if we only check if the person has fever or not is not enough to ensure safety of the people from COVID-19. Studies say that it takes from two to fourteen days to develop the symptoms of COVID-19 and the infected can spread the virus in this short time. It is also said that approximately 59% of all COVID-19 transmissions is caused by PR symptomatic individuals who have not yet developed any symptoms and asymptomatic people who never developed any symptom[1]. It is proven that; Oxygen saturation level is very important evidence in terms of detection of COVID-19. We have implemented ways to measure both body temperature and oxygen saturation level. Apart from symptoms, it is a must to wear masks all the time to stop the virus from spreading cause the mask can prevent the virus from spreading from an infected person or even stop it from affecting a healthy person. It is addressed that a person should wear a mask even if he or she is vaccinated. Wearing a mask is considered the most effective way to fight against COVID-19. Another way that the virus can spread is touch. If people touch anything that was touched by an infected person before and it hadn't been sanitized, there is a high chance of getting infected by COVID-19. For this reason, we have made our system as much contact less as possible. We have seen in our country that thousands of front-line people like police, doctors, security guards died while protecting the country from this dangerous virus. Security guards are most prone to this criterion as some of them are assigned to screen people restlessly. Some studies by ONS UK showed that men working as security guards have one of the highest death rates, with 45.7 death per 100,000[2]. We are still fighting this virus and trying to find a sustainable way to solve this pandemic and Our project just might be the answer to it.

### **1.1.3 Literature Review**

#### **Literature 1:**

The author of this paper has developed a face mask detection system using TensorFlow and OpenCV. In this system, after analyzing a dataset from the Kaggle Repository, the author divided it into training and testing data. After that, a default OpenCV module was used to gather faces, and a Keras model was trained to recognize face mask[3]. Furthermore, if a person is not wearing a mask, the system will detect it using the OpenCV model and email the person using smtplib.

#### **Literature 2:**

This paper had a thorough research on no-contact infrared thermometer. A thermometer with a Fresnel lens and an optical filter was created by the author. The lens collects infrared radiation generated by a measuring item and concentrates it onto a detector. TS118-3, a thermoplastic sensor for contact less temperature sensing, is used as a photoelectric transfer device[4].

#### **Literature 3:**

In this paper, the author has designed a face mask detection system using TensorFlow, Keras and OpenCV. The author suggested an approach that combines a cascade classifier with a pre-trained CNN with two 2D convolution layers coupled to dense neuron layers[5].

#### **Literature 4:**

The author of this paper developed a pulse oximeter using the CMS50D sensor. The pulse oximeter gadget performed various tasks, including real-time monitoring of heart rate and oxygen saturation, real-time monitoring of the PPG signal waveform[6] , and real-time extraction of heart beat moments for graphing.

### **1.1.4 Literature Gap**

From all the literatures we have discussed, we can see that most of the literature topics were based on one single component. The project that we have come up with is a whole system which has all the features we have discussed so far but also it has some more features to provide more safety. Moreover, we have implemented the dynamic logic system which gives our system more space to work with more accuracy.

### **1.1.5 Relevance to current and future Industry**

COVID-19 has been around us for over two years now and it might still be with us for a while since it can mutate very rapidly and new strains like Delta or Omicron are coming each year. So, we can say COVID-19 might be with us for a while like the Flu virus. The project that we proposed is an automated entry system with very minimal requirements and we can say that this product can be relevant for a long time since in can be used in any entry point of any industry, institution or corporation. Thus, we can say that our product can be relevant to the market for a long time.

## **1.2 Objectives, Requirements, Specification and constant**

### **1.2.1 Objectives**

COVID-19 is keeping the world halted for almost two years now. Although the world has started to cope up with this virus still the risk of getting infected is considerably high because this virus is really infectious. If a healthy person goes too near to an infected person for a few moments, he has a high chance of getting infected. The primary objective of our project is to Create a safer work environment by checking if a person has taken certain precautions or he or she has any symptoms or not. To achieve this objective, we have taken four sub objectives which will help us in completing our main objective and they are:

- To use RFID based student/teacher entry and log database.
- To use machine learning models to detect if a person is wearing a mask or not.
- To use a contact-less infrared thermometer to check a person's temperature.
- To use a pulse oximeter to check a person's oxygen saturation level.
- To store the data on a database server for monitoring.

### **1.2.2 Functional and Nonfunctional Requirements**

The requirements for our system can be divided into two separate parts, Functional and Non-Functional requirements.

#### **Functional requirements**

As for the functional requirements, there are some system level requirements which the system needs to fulfill in order to attain the objectives. The system level functional requirements are as follows:

- The system needs to be able to accommodate around 500 hundred people within 90-120 minutes.
- The system needs to identify the person entering the premises.
- The system needs to determine if the person has maintained the proper health protocols and if the person has any COVID-19 symptoms or not.
- The system needs to collect the data and also store the data into an online or offline server.

To meet the system level requirements, the system needs some component level requirements. The component level requirements are as follows:

- The system needs a RFID system to identify the person trying to enter.
- The system needs a face mask detection system to identify if a person has taken
- The system needs a Thermometer to determine if a person has fever or not.
- The system needs a pulse oximeter to determine the oxygen saturation level of a person
- The system needs an offline server or more preferably an online real time database to store the collected data.

#### **Non-Functional requirements**

Along with the functional requirements, we have some non-functional requirement which can make the system better.

- The system should be able to clean the pulse oximeter after every use.

- The system should have a way to disinfect the user after usage.
- The system should monitor the stored data to predict if a person may be infected or not.
- The system should be able to detect the COVID-19 symptoms through more advanced measures.

In order to fulfil the non-functional system requirements, we need some component level requirements:

- The system needs to have an infrared blaster to disinfect the pulse oximeter continuously.
- The system must have a way to dispense some hand sanitizer after the usage.
- The system can have an X-ray machine to see if the lungs of a person is infected or not.

### 1.2.3 Specifications

To achieve every objective of our project, we have set a certain set of specifications so that it can meet the requirements. As we are working for creating a safer work environment for the people during this pandemic, we have to cover that health checkup area to make the project a viable one. So, the specifications of our project are as follows:

- **RFID Card reader module:**
  - i. This module can read card in the distance of 0 to 60mm.
  - ii. The working frequency for this is 13.56MHz, so this needs to be maintained.
  - iii. This module doesn't require contact to read the card.
  - iv. He digital part handles the ISO14443A frames and error detection.
  - v. Follows SPI protocol.
  - vi. Working and storage temperature is -20 to 80 degrees, so this temperature needs to be maintained.
- **MAX30100 Pulse Oximeter Heart rate sensor:**
  - i. It works with 3.3V supplied power.
  - ii. Ultra-low power operation increases battery life for wearable devices
- **MLX90614 Contactless Temperature Sensor Module:**
  - i. Internal 17-bit ADC and a powerful DSP contribute high accuracy temperature measurement.
  - ii. Factory calibrated in wide temperature ranges: -40 to 85°C for the ambient temperature and -70 to 382.2°C for the object temperature.
  - iii. Offers a standard accuracy of  $\pm 0.5^{\circ}\text{C}$  around room temperatures.12/20
- **Raspberry pi camera v2:**
  - i. Needs 3.3V supply voltage
  - ii. On the genuine Pi camera modules, the voltage regulators for the sensor itself are controlled by a GPIO up a different line on the ribbon.
- **Raspberry pi 4:**
  - i. Works with 3.3- 5 V supply voltage
  - ii. Can work up to 1.5 GHz boost clock

- **Firestore:**
  - i. The Realtime database of this cloud storage device provides us 1 GB of free data, after that it costs \$5 USD/GB
  - ii. Can provide up to 100 simultaneous connections.
  - iii. 10 GB/month can be downloaded for free, after that it costs around \$1 USD /GB

#### **1.2.4 Technical and Non-technical consideration and constraint in design process**

We have faced different obstacles while designing this project and we have modified our project, ran different designs and finally chose the most optimal design. Some of the constraints that we faced while working are as follows:

- Firstly, we had problem finding the perfect data set for our face mask detection. For the machine to learn about perfect face mask we had to look for a long time. Even though we found several sets on the internet, none of them were perfect and we need this to be as perfect as possible because if appropriate data set is not chosen, someone who is not wearing a mask properly or not even wearing a proper mask might get in. For this, appropriate data set was mandatory.
- In our first design, we designed it using Arduino Uno. That particular control board had very few ports and for this we had to implement two Arduino Uno's which is a very hard procedure also costly. For this reason, we switched to the Raspberry Pi 4 which has more ports, convenient and also cost efficient.
- To ensure the safety of the people using the Pulse Oximeter, we decided to use a hand sanitizer station so that people can clean their hands using the system.

#### **1.2.5 Applicable compliance, standards, and codes**

This project has been divided into pieces. They are the RFID log, the detection of face masks, the measurement of blood oxygen saturation levels, and the body temperature check. The gadget is constructed from a variety of components. The components we utilized adhered to all of their respective standard codes. And we addressed all these codes in our previous reports. In view of the system that we have in our hands right now is a complete automated system. Which relates to biomedical engineering concepts as it is a health monitoring system. We tried to follow the IEEE 11073 standards that targets point-of-care and personal health and fitness devices (such as glucose monitors, pulse oximeters, weighing scales, medicine dispensers, and activity monitors) as well as ongoing and acute care devices (such as pulse oximeters, ventilators and infusion pumps). They are a set of standards that may be put together to offer a connection that is optimal for the devices being interfaced. In the first place, we emphasize the public's safety, health, and well-being. Furthermore, because the many components of our projects have already been completed, we have devised a way to keep these works in sync while we complete the project entirely within our areas of expertise. We also avoided any dishonest practices while carrying out our assignment. To promote the profession's respect, prestige, and utility, we must market this endeavor while honoring obligations, ethics, and adhering to the law. We are committed to completing the job while adhering to all engineering requirements. All of these ethical guidelines are consistent with the NSPE codes (National Society of Professional Engineers).

### 1.3 Systematic Overview/summary of the proposed project

The project we have proposed is a Raspberry pi based automated entry system which has some health protocols embedded so that people who try to enter a certain area have no COVID-19 symptom and are wearing a mask. The micro controller board of our project is the Raspberry Pi 4 which is a single board computer designed by the Raspberry Pi Foundation. The Raspberry Pi can be programmed using the Python language for any kinds of use. In our project, we have one thermal sensor which will determine the body temperature of a person and determine if that person has fever or not, a sensor to measure the oxygen saturation of a person and a camera which will detect if the person is wearing a mask or not. After measuring all the variables, the program will determine the risk level of the people[7]. If the person does not pose any high threat, the system will let the person in.

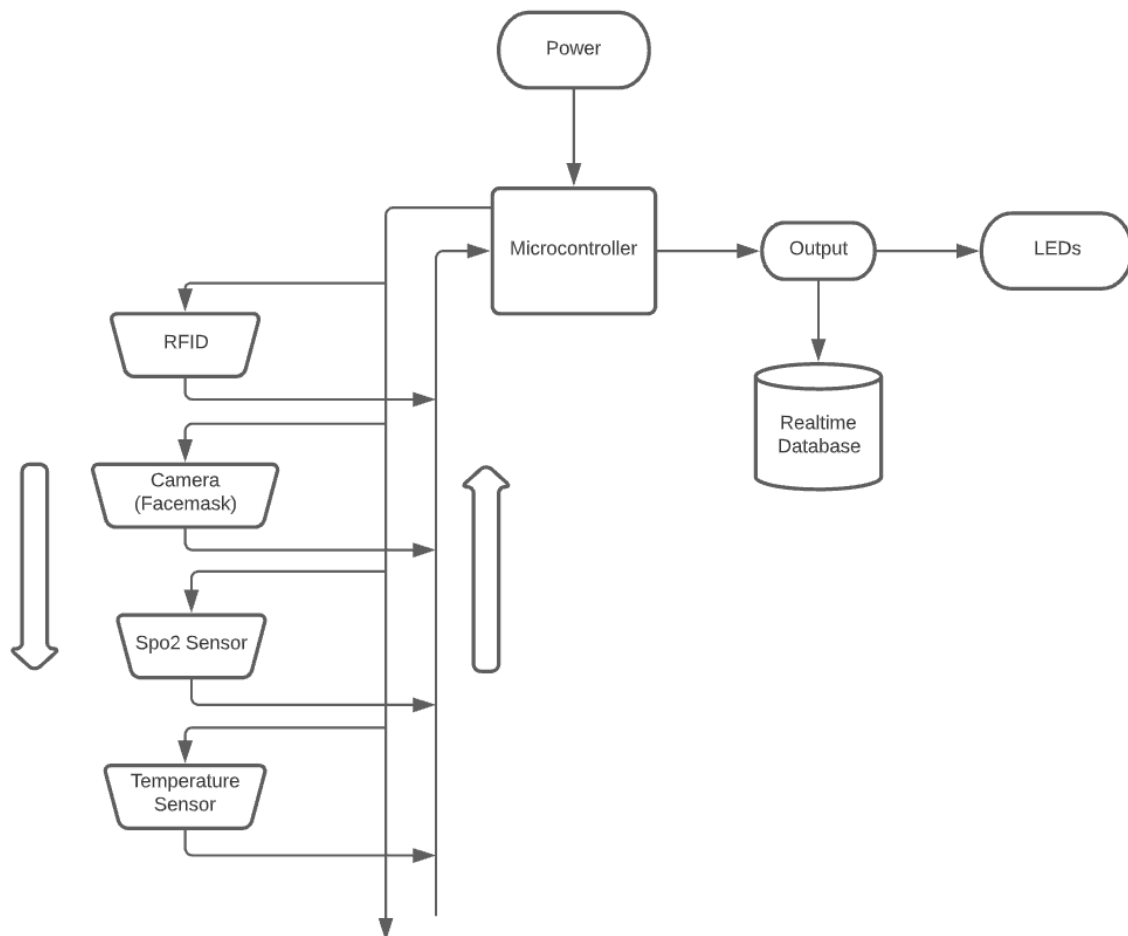

Fig.1 System block diagram

### 1.4 Conclusion

Our main objective of this project is to develop a IoT based anti-COVID-19 entry system to create a safer work environment during this pandemic. To attain this objective, we are developing a system where we have implemented all possible ways to determine whether a person is infected or not and the system will let the person enter based on the risk level of the person. In this chapter we have discussed about the problems and the possible solutions. This project can help to make the work environment a lot safer even in this pandemic.

## **Chapter 2: Project Design Approach**

### **2.1 Introduction**

To achieve the proposed objective of our FYDP project, we have identified two different design approaches based on our design requirements. Our multiple design approaches are based on the algorithm differences, core component differences and data system differences. These two systems have their very own way of work and delivering the objectives they have been assigned to. To achieve this, they follow their distinctive criteria and characteristics.

### **2.2 Identify multiple design approach**

The two multiple designs that we have come up with to deliver us the outcome that we are speculating are –

- i. Binary decision algorithm system using single data manipulation with Developer Kit.
- ii. Dynamic decision algorithm system with effective stand-alone Microcontroller.

### **2.3 Describe multiple design approach**

Both of the designs have been developed having some key factors in mind which can be used to distinguish between these two design approaches. The whole description of each of the design approaches have been explained below –

#### **1) Binary decision algorithm system using single data manipulation with Developer Kit**

Initially the approach that we have had taken was a simple system to easily implement the system in most efficient way. So, we found our solution into a system which we will develop with microcontroller, integrated with a developer kit (Nvidia jetson developer kit). For the internal core programming part, we went with binary decision algorithm as it is very simple. More the complication, more the efficiency loss was our focus. That is why we went with a simple algorithm, along with a linear single data manipulation to make the system more efficient.



## Flow of the system (Binary)

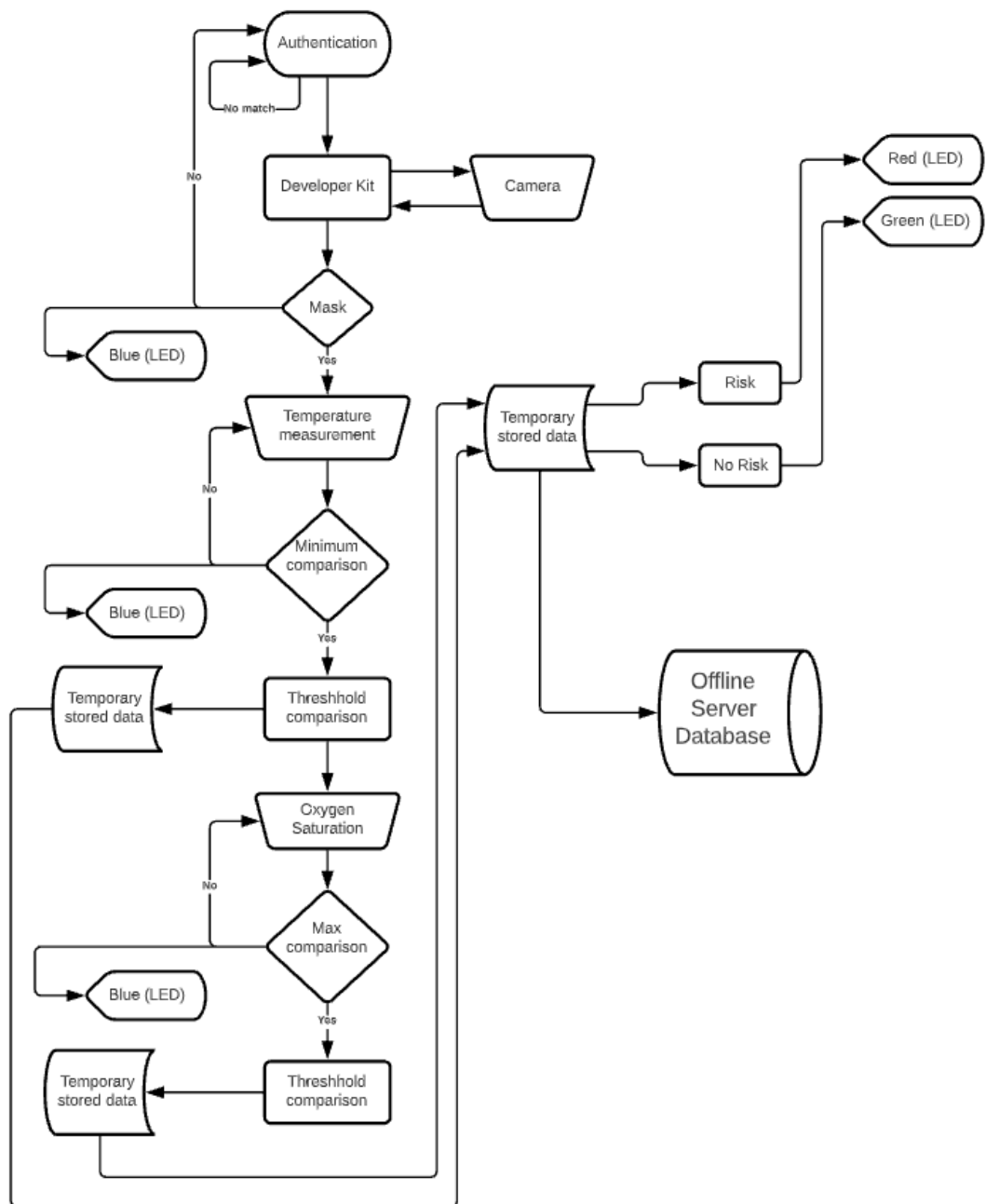

Fig.2 Flowchart of system 1

## Algorithm (Binary)

```

Packages import
Libraries call
Initialization of Pins
  
```

# Initially all the necessary packages and libraries to run all the components are being imported. Then the pins of the microcontroller are being initialized.

```
Turning on pins
Sensors switches ON
Reading data from RFID
Reading data(facemask) from developer kit
```

# Microcontroller pins are being turned on here along with the sensors. Firstly, the RFID and the facemask detection by developer kit part is starting to reading data subsequently from the user.

```
If (mask = False)
    Return
```

# At this point, if the facemask detection portion of the code doesn't recognize any face or any masked face, the system will return to the initial point which is Reading data from RFID. Otherwise, the system will move forward into the next stage.

```
else
    Reading data from MLX90614
    if (temperature >= 95 and temperature < 108)
        Break
    else
        Loop back
        Blue (LED)
```

# The system is reading temperature data from the user through the sensor. If the read data is not in the limit (95<Temperature<108), the system will return to the Reading data from MLX90614 stage and ask the user to try again. But if the data is in the limit, then the system will move forward.

```
If (temperature >= 100.4)
    Factor = High Risk
else
    Factor = No Risk
```

# Now the data which was in the limit of 95<Temperature<108 will be evaluated for risk level. If the data is above the limit (Temperature<100.4), then the result of "No Risk", otherwise it will be "High Risk" will be temporarily stored.

```
if (mask = true)
    Reading data from MAX30100
    if (o2_saturation >= 90 and o2_saturation <= 100)
        Break
    else
        Loop back
        Blue (LED)
```

```
# The system is reading oxygen saturation data from the user
through the sensor. If the read data is not in the limit
(90<Oxygen-Saturation-level<100), the system will return to the
Reading data from MAX30100 stage and ask the user to try again.
But if the data is in the limit, then the system will move
forward.
```

```
    If (o2_saturation <= 95)
        Factor = Risk
    else
        Factor = No Risk
```

```
# Now the data which was in the limit of 90<Oxygen-Saturation-
level<100 will be evaluated for risk level. If the data is
under the limit (Oxygen-Saturation-level<95), then it will be
“No Risk”, otherwise it will be “High Risk”.
```

```
Indicator (risk factor)
```

```
    If (No Risk)
        Green (LED)
    elif (Risk)
        RED (LED)
```

```
# Here, the indicator LEDs will start working to show the risk
level of the user’s given data. If the risk = No Risk, then the
Green LED will turn off otherwise the Red LED will turn on for
few minutes to let the user know of the result.
```

```
Offline data storage
```

```
    {“ID”, “Name”, “Mask”, “o2_saturation”, “Temperature”,
    “Date”, “Time”}
```

```
# Finally, all the collected data by the sensors will be sent to
an offline server into a database for monitoring.
```

```
Repeat
```

```
# From here on the while system will repeat itself with the start
of RFID card reading until the system is turned off.
```

## 2) Dynamic decision algorithm system with effective stand-alone Microcontroller

After we had collected resources and evaluated our initial design, we wanted to try a different approach to do a comparison between them to come up with the best possible solution for the problem then we have state. With that in mind we came up with a somewhat different approach or opposite approach to what we had done initially, that is completing the project with a single powerful microcontroller which can replace additional developer kit’s need and will work as a stand-alone

processing unit. Along with that we planned to use Dynamic decision algorithm as it gives us more customizability and precision in detection of covid risk as we can reason with the acquired data. Due to usage of dynamic system, we also planned to use batch data manipulation method. This method will do data manipulation only a single time for each user, which will make the system more accurate without slacking off in terms of efficiency.

### Flowchart of the system (Dynamic)

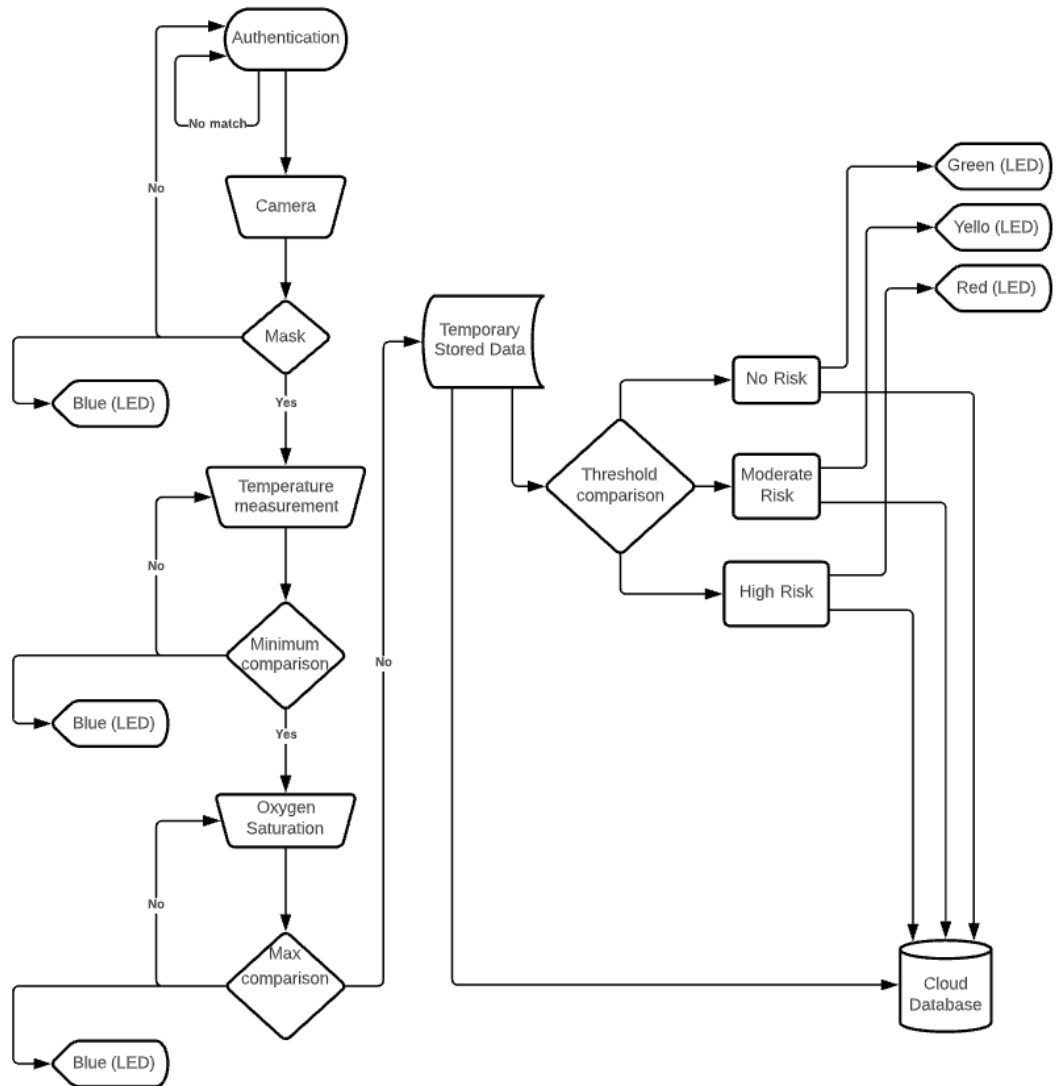

Fig.3 Flowchart of system 2

### Algorithm (Dynamic)

```

Packages import
Libraries call
Initialization of Pins
  
```

# Initially all the necessary packages and libraries to run all the components are being imported. Then the pins of the microcontroller are being initialized.

```
Turning on pins
Sensors switches ON
Reading data from RFID
Reading data(facemask) from Pi-Camera
```

# Microcontroller pins are being turned on here along with the sensors. Firstly, the RFID and the facemask detection by raspberry pi camera part is starting to reading data subsequently from the user.

```
If (mask = False)
    return
    Blue (LED)
```

# At this point, if the facemask detection portion of the code doesn't recognize any face or any masked face, the system will return to the initial point and it will show a Blue LED for a few seconds to let the user know to try again which is Reading data from RFID. Otherwise, the system will move forward into the next stage.

```
Else
    Reading data from MLX90614
    if (temperature >= 95 and temperature < 108)
        Break
    else
        Loop back
        Blue (LED)
```

# The system is reading temperature data from the user through the sensor. If the read data is not in the limit (95<Temperature<108), the system will return to the Reading data from MLX90614 stage and ask the user to try again and it will show a Blue LED for a few seconds to let the user know to try again. But if the data is in the limit, then the system will move forward.

```
if (mask = true)
    Reading data from MAX30100
    if (o2_saturation >= 90 and o2_saturation <= 100)
        Break
    else
        Loop back
        Blue (LED)
```

# The system is reading oxygen saturation data from the user through the sensor. If the read data is not in the limit (90<Oxygen-Saturation-level<100), the system will return to

the Reading data from MAX30100 stage and ask the user to try again and it will show a Blue LED for a few seconds to let the user know to try again. But if the data is in the limit, then the system will move forward.

```
    if (temperature < 99 and o2_saturation t > 95)
        risk = 'No Risk'
    elif (temperature > 99 and temperature < 100.4 and
o2_saturation > 95 or temperature < 99 and
o2_saturation < 95 or temperature > 100.4 and
o2_saturation > 95)
        risk = 'Moderate Risk'
    else:
        risk = 'High Risk'
```

# Now this is the risk factor evaluation part of the wholes system. If the user's given data is in the limit of temperature < 99 and o2\_saturation t > 95, the system take that as a "No Risk" factor. If the user's data fall under any on the conditions like temperature > 99 and temperature < 100.4 and o2\_saturation > 95 or temperature < 99 and o2\_saturation < 95 or temperature > 100.4 and o2\_saturation > 95, the system will take that as "Moderate Risk" factor. In any other cases, the system will take that as "High Risk" factor.

```
Indicator (risk factor)
If (No Risk)
    Green (LED)
elif (Moderate Risk)
    Yellow (LED)
else (Risk)
    RED (LED)
```

# Here, the indicator LEDs will start working to show the risk level of the user's given data. If the risk = No Risk, then the Green LED will turn on, if the risk = Moderate Risk, then the Yellow LED will turn on otherwise the Red LED will turn on for few minutes to let the user know of the result.

```
Cloud data storage
{"ID", "Name", "Mask", "o2_saturation", "Temperature",
"Date", "Time"}
```

# Finally, all the collected data by the sensors will be sent to an online cloud server (Firebase) into a Realtime database for monitoring.

Repeat

# From here on the while system will repeat itself with the start of RFID card reading until the system is turned off.

## 2.4 Analysis of multiple design approach

### 1) Binary decision algorithm system using single data manipulation with Developer Kit

#### Binary decision algorithm

The project that we are developing is a health protocol related project. In this scenario, it is a risk mitigation-based project. So, naturally we are obligated to let the users know the outcome in such manner that it is clear to the users. Having that in mind we have come up with this algorithm which is binary in nature. This algorithm gives us the result in yes/no fashion. After the health protocol evaluation, if the system finds the data to be in risk zone, the system will output “RISK” prompt and in the other case it will output “NO RISK” prompt.

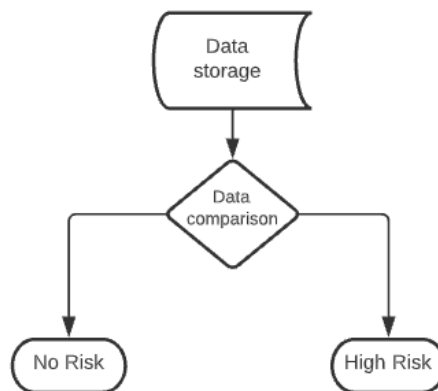

Fig.4 Binary decision algorithm

For the shown risk factors, the threshold data that we work with are WHO approved limit of body temperature and blood oxygen saturation level (SpO2 level).

#### Case 01: No Risk

For this particular case, the parameters are as follows –

```
if temperature < 100.4 and o2_saturation > 95:  
    risk = 'No Risk'
```

#### Case 02: Risk

In term of this case, the parameters are as follows –

```
if t temperature > 100.4 and o2_saturation < 95:  
    risk = 'High Risk'
```

#### Developer kit approach

In this project there are few distinctive objectives that we have to full fill. One of those objectives is related to machine learning where we need to detect the users face and the

mask to evaluate whether they are wearing or no wearing any mask. Now, this machine learning related work are normally done in highly capable setup with high performing Cuda-cores of Graphics Processing Unit. But in this case, we have to do it portably and, in a manner, so that it is also efficient. The developer kit is a way to go in this case to do it portably without losing any noticeable efficiency. Preferably NVIDIA Jetson Nano Developer Kits are used to harness the performance power of the Cuda-cores.

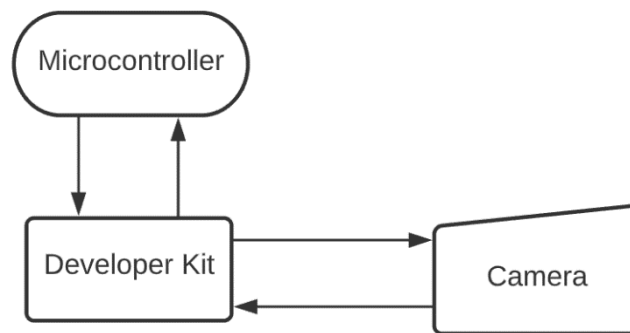

Fig.5 Developer kit system

### Single data manipulation

Here, we are using multiple sensors to collect data to verify and fulfill the health protocol that we are planning to check. In the data manipulation, we planned to work with single data at a time. So, after collecting the data we will compare the data with the threshold data and store the result temporarily. Then we will go on to the next sensor data. This way after the final sensor data we will be able to give out the result of the health check instantaneously. In a binary decision algorithm system this single data manipulation process works perfectly as the result will always be False or True with the comparison result of a single data. This way the coding is very efficient too.

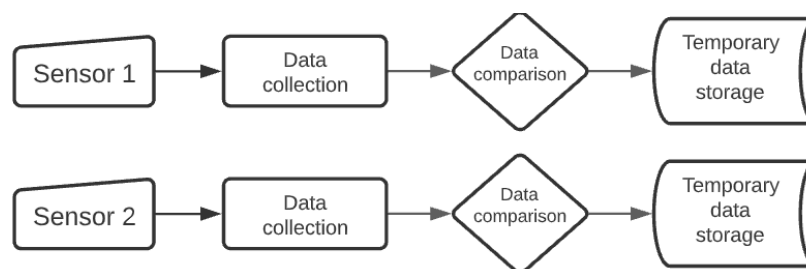

Fig.6 Single data manipulation

## 2) Dynamic decision algorithm system with effective stand-alone Microcontroller Dynamic Decision algorithm

The project that we're working on is a health protocol project. It is a risk mitigation project in this case. As a result, we are naturally compelled to inform consumers of the results in a way that is both obvious and truthful. We devised this algorithm, which is dynamic in nature, keeping the correctness of the output in mind. This method provides



us with a precise result. After the health protocol evaluation, if the system finds the data to be in risk zone, the system will output “High Risk” prompt, if the risk is moderate the prompt will be “Moderate Risk” and in the other case it will output “No Risk” prompt.

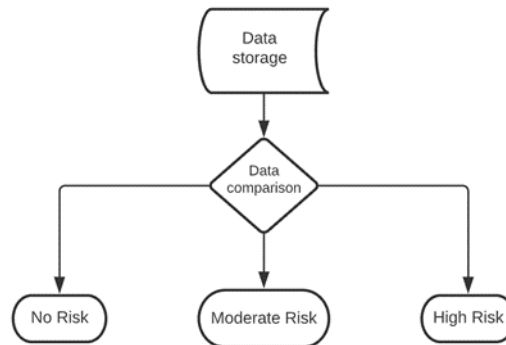

Fig.7 Dynamic decision algorithm

In dynamic decision making we can reason with the data and get an accurate result from that. We can see multiple different outcomes from different cases. The cases are given below:

- **Case 01 – No Risk**

In term of this case, the parameters are as follows –

```

if temperature < 99 and o2_saturation > 95:
    risk = 'No Risk'
  
```

- **Case 02 – Moderate Risk**

For this case, the parameters are as follows –

```

if temperature > 99 and temperature < 100.4 and o2_saturation > 95
or temperature < 99 and o2_saturation < 95 or temperature > 100.4
and o2_saturation > 95:
    risk = 'Moderate Risk'
  
```

- **Case 03 – High Risk**

Finally, to determine risk factor in this case the parameter that we followed are

```

if temperature > 100.4 and o2_saturation < 95:
    risk = 'High Risk'
  
```

### Stand-alone Microcontroller

There are a few key objectives that we must meet in this endeavor. One of the goals is to utilize machine learning to recognize the user's face and mask in order to determine whether they are wearing or not wearing a mask. This machine learning work is now often done in a high-capacity configuration with high-performance Cuda-core Graphics Processing Units. However, in this situation, we must do so in a portable and efficient

method. That is why we have chosen a microcontroller for our system which will make the attachment of an external developer kit obsolete and powerful enough to run the necessary processes by itself.

### Batch data manipulation

We are currently working on a data-driven project. We're collecting data using several sensors to validate and complete the health routine we're testing. To identify the risk level, we must gather, store, compare with the ideal threshold data, and save the comparison data. For the system 2, we have planned to work with batch data manipulation. Here we will collect all the sensor data initially and store them in a temporary storage. Then after completion of collecting data, we will compare the data with the threshold data to get our result. This process works best with dynamic decision algorithm as we can get much more accuracy while working with multiple data at the same time.

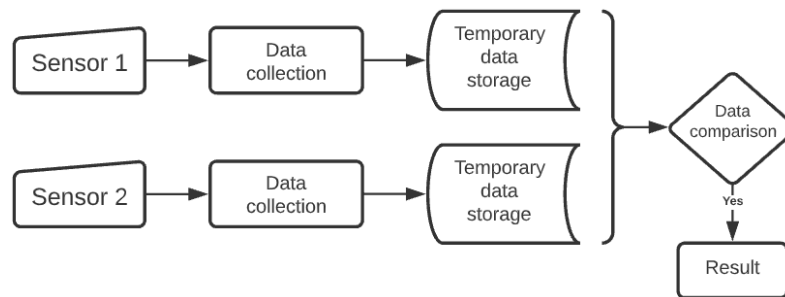

Fig.8 Batch data manipulation

## 2.4 Conclusion

Finally, we can say that, both of the design approach has their unique features that makes them distinctive in their own way. The binary system is very efficient but the dynamic system is very customizable and precise. With the dynamic decision algorithm along with a powerful microcontroller, the system can be a very effective and reliable device.

## Chapter 3: Use of Modern Engineering and IT Tool.

### 3.1 Introduction

Development of a project requires different kinds of engineering tools and IT tools. For the development and implementation of the project we had to use both software and hardware.

### 3.2 Select appropriate engineering and IT tools

The tools that have been used are used to develop complex engineering project. The lists are as follows:

#### 3.2.1 Hardware

- Raspberry Pi 4 B
- RFID sensor
- MLX90614 infrared temperature sensor
- MAX30100 SpO2 sensor
- Breadboard
- Soldering Iron
- Wires
- Resistors

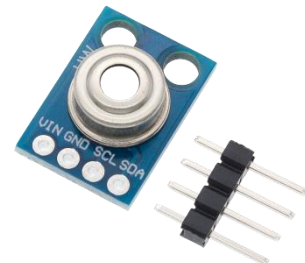

- Raspberry Pi Camera V2



### 3.2.1 Software

- Visual Studio Code

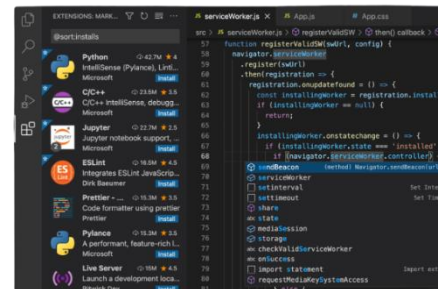

- AutoCAD



- Debian Buster Raspberry Pi OS



- Firebase Realtime Database



### 3.3 Use of modern engineering and IT tools

#### Use of Hardware tools:

- Raspberry Pi 4 B:

This is the master controller in this device. This device will be connected with multiple sensors

and pi camera and output LEDs two establish the whole system.

- **RFID sensor:** This technology is used to authenticate the user's accessibility to certain building using radio frequency tag. This module was connected to the raspberry pi through SPI interfacing. This module will read the external RFID tags to verify the UID that is embedded on that particular tag.
- **MLX90614 temperature sensor:** Used for non-contact temperature measurement. This is an infrared sensor. This sensor is connected to the raspberry pi through I2C interfacing to get data to the raspberry pi.
- **MAX30100 SpO2 sensor:** Used for body oxygen saturation level measurement. This sensor is connected to the raspberry pi through I2C interfacing to the I2C bus of the raspberry pi.
- **Breadboard:** The implementation of the prototype was done on the breadboard as it is easily customizable according to our needs as multiple devices needed to be connected in parallel manner to same bus.
- **Soldering Iron:** This tool was used to solder the pin heads to the sensors permanently so that the sensors don't get disconnected during the experimentation.
- **Wires:** For all kind of communication between sensors and the microcontroller, these 2mm wires were used.
- **Resistors:** Mainly attached in parallel connections to be used as pull up to strengthen the signal integrity of the sensors.
- **Raspberry Pi Camera V2:** It was connected to the camera header connection of raspberry pi board to be used as the native camera. This camera was used to detect face and facemask in this project.

### Use of software tools:

- Visual Studio Code: This is an IDE for multiple programming languages. As our whole project was backed by python programming, we used this IDE to develop our program before implementing that to the raspberry pi. Specially, the face-mask detection code was developed on this IDE on a computer to be trained. That that pre trained model was used in the raspberry pi as raspberry pi's compiler can't take such load as VS code.
- AutoCAD: AutoCAD is a commercial computer-aided design and drafting software application. In our project, we needed to build the whole schematic to implement it. AutoCAD was used to build the schematic as it is a very handy tool and has wide range of sensors in its library. Also, the 3D render and 2D render of the whole device was developed using AutoCAD to be laser cut as it helps to prepare precise render of the planned device.
- Debian Buster Raspberry Pi OS: This operating system was used to run Raspberry Pi 4 B microcontroller. This particular OS was used because it has python 3.7 as it's default programming language. This version of python has most resources matched with it which were needed to complete the project such as libraries, packages etc.
- Firebase Realtime Database: As this is an IoT based project, the integration with a cloud server is indispensable and Firebase Realtime database was used to store the user data to monitor them.

### 3.4 Algorithm development:

Multiple algorithms were explored to acquire the desired result from the system. The algorithm which was developed, was designed such a way so that it works with the system seamlessly. The core work process of the system was *Authentication > Face-mask Check > If yes, move forward. If no, return to authentication > Temperature test > if in desired bound, move forward > If not in desired bound, return to Temperature test > Pulse oxygen saturation check > if in desired bound, move forward > If not in desired bound, return to Pulse oxygen saturation check > Risk factor calculation > LED trigger according to risk factor > Data upload to real-time database > Return to Authentication.*

This way the whole programming of the system was done, so that it can run in a continuous loop with no break or fault.

### **3.5 Conclusion**

We have fully concentrated on displaying all of the contemporary IT technologies used in the project compilation in this chapter. We had to complete the project prototype in a certain amount of time, therefore choosing and employing the right IT technologies was critical from the start. The preceding lists and descriptions are based on the direction and criteria.

## Chapter 4: Optimization of Multiple Design and Finding the Optimal Solution.

### 4.1 Introduction

The complex engineering problem that we have planned to solve can be solved in several ways that we have already declared. The objective that we have presented, needs to be fulfilled to prove a design method as a solution. But only achieving the objectives are not the final outcome of a complex design solution. We have to test the design approach in various ways to truly procure an optimal design out of all the design approaches. The optimal design is the one that will have the best balance of effectiveness, efficiency, cost sufficiency and usability to the users. As the project that we are preparing is an entry system with health protocol implementations, the best design for this project has to has efficiency in both usage and cost, has to be user friendly and the maintenance has to be simple and the manufacturability should also be taken in account.

### 4.2 Optimization of multiple design approach

#### 4.2.1 Optimization based on efficiency and effectiveness

As this is an entry system project, the operation time of the device needs to be very efficient to keep up with the necessity of the crowd, especially during the rush hours. That is why the first thing that comes to mind is better processing unit should be used and much more efficient algorithm needs to be used to mitigate any kind of latency. The adoption of binary decision algorithm with developer kit system. As the developer kit such as Nvidia jetson nano can provide that processing power to run everything swiftly. In this case the hardware is more than capable of delivering efficient outcome but the accuracy of result is another thing that needs to be taken in account which the binary decision algorithm fails to deliver.

Whereas, in term of system 2 we used dynamic decision algorithm we use reasoning to declare whether someone is in risk or what's the level of risk. In the hardware part we use the Raspberry Pi 4 B microcontroller to support the software load. The raspberry pi 4 B is somewhat a very capable device too to handle processing load. Let's see the comparison [1] of these two systems in terms of efficiency and effectiveness in accuracy side by side:

TABLE I System 1 vs System 2's Efficiency and Effectiveness Comparison

Factors	Specification	System 1	System 2
Output Accuracy		2 Conditions	6 Conditions
Hardware efficiency	Processor	- 1.42 GHz quad-core ARM Cortex-A57 64-bit.	- Broadcom BCM2711 system-on-chip. - 1.5-GHz quad-core 64-bit ARM Cortex-A72 CPU
	Memory	- 2GB - 4GB - LPDDR4	- 1GB - 2GB - 4GB - 8GB



			-LPDDR4-2400 SDRAM
	GPU	- 128-core Maxwell GPU at 921 MHz	- Broadcom VideoCore VI
	Connectivity	- Gigabit Ethernet - M.2 Key E Wi-Fi	- Gigabit Ethernet - Built in Wi-Fi - Built in Bluetooth

From the above comparison we know that The Cortex-A72 in the Raspberry Pi 4 is one generation newer than the Cortex-A57 in the NVIDIA Jetson Nano. This CPU offers higher performance and faster clocking speed. This shows the efficiency of raspberry pi is higher in everything except face-mask detection than jetson nano's facemask detection due to its GPU power.

#### 4.2.2 Optimization based on cost

The project that we are using is data driven and requires processing power much higher as we are using Machine Learning technology to detect face-mask. So, the initial system design that is consist of binary decision algorithm and developer kit is a very capable system due to its powerful processing unit. To mitigate the over cost of the developer kit such as Nvidia jetson, we planned to use Arduino Uno along with it as the master slave which will have been used in a serial connection with the developer kit only because Arduino Uno is not a capable microcontroller for Machine Learning related task like object detection.

However, if we adopt the system 2 as the design, we can use a single microcontroller which is raspberry pi 4 B as the stand-alone processing unit which can handle all the operations all by itself without any external processing unit's support. Now, if we see the cost compassion below, we can come closer to our decision:

TABLE II Raspberry Pi 4 and Jetson Nano price comparison

Factor	Specification	Raspberry Pi 4 B price (\$)	Nvidia Jetson Nano price (\$)
RAM	2GB	35	60
	4GB	55	100
	8GB	75	N/A

Here we can see the clear difference between same variant price among them which is a lot stiff to accept jetson nano developer kit as a valid choice. Moreover, this is not all, the Arduino Uno's cost will be added onto the Jetson Nano's price if we adopt system 1.

### 4.2.3 Optimization based on usability

One of the most overlooked factors in engineering problem solving sometime can be usability from both user and the owner side. For a design to be the optimal, it's usability needs to be up to the marks too.

From the owner's perspective the usability factors are mainly the accessibility to the device and the data in this case.

TABLE III System Usability Comparison from owner's POV

Factors	Specification	System 1	System 2
Measurement		Bulky (Arduino + Developer kit + Offline server)	Compact (Single stand-alone controller)
Hardware	I/O	- 4 USB 3.0 - 1 USB 2.0 Micro - B - 1 Display Port - 1 HDMI port - 2 Camera Serial Interface (CSI)	- 2 USB 3.0 - 2 USB 2.0 - 1 USB C - 3.5 mm analog audio-video jack - 2 Micro HDMI port - Camera Serial Interface (CSI) - Display Serial Interface (DSI)
Algorithm Efficiency	Congestion	High	Medium - Low
Data Storage		Offline server	Online cloud Realtime database

The usability in terms of all three factors here favors the system 2 as that offers much more portability, remoteness and accessibility to the device.

### 4.2.4 Optimization based on maintainability

The high number of usages means good amount of maintenance is required to keep the device functional. The cost comparison has a big role in terms of maintainability as it directly connects both of the devices to the maintained cost. Also, the size and portability of the device is a factor too in this case.

For the system one the measurement is larger as two controllers are being used in serial connection to fulfill the objectives and the cost is much higher due to the advance developer kit. Also, the system needs to be connected to an offline server all the time to send the data to a database to monitor which makes it less portable.

However, for the second system the device is much more compact in shape which makes it easy to maintain. Also, the maintenance cost is lower compared to the other system due to low cost of the components in the first place. Finally, the system integrates a cloud server, which makes it portable as it's not attached to anything other than power.

#### 4.2.5 Optimization based on manufacturability

Manufacturing process is consisted of initiation, formulation, component integration, software implementation etc. The simpler a device is the easier it is to manufacture, also the cost of manufacturing is much lower if the design is not complex. The system 1 requires communication between two controller which complicates thing in both hardware and software implementation aspect.

For the system 2, the design is much simpler and the integration are very straight forward, which make the manufacturing much easier.

### 4.3 Identify optimal design approach

#### 4.3.1 Optimal use of widely available components

The components that are being used to develop the system 2 design are widely available in the market which will help us in terms of developing, manufacturing and getting recourses for this product much more easily. The components that are being used in system 1 such as developer kit is very lightly used component in market.

Also, the resources such as support, OS, libraries for raspberry pi have and abundance on the internet where's system 1 has very less.

#### 4.3.2 Cost effectiveness

TABLE IV Two System's Cost Analysis

Components for system 1	Quantity	Price in BDT (₹)	Components for system 2	Quantity	Price in BDT (₹)
Arduino Uno	1	640	Raspberry Pi 4 Model B 4GB	1	7,500
Nvidia Jetson Nano	1	14,900	Micro HDMI to Standard HDMI Cable	1	398
Transcend Microsdxc/sdhc 300s 32GB Memory Card	1	625	Transcend Microsdxc/sdhc 300s 32GB Memory Card	1	625
MAX30100 Finger Oximeter Heart Rate Module	1	500	MAX30100 Finger Oximeter Heart Rate Module	1	500
Infrared Thermometer – MLX90614	1	1099	Infrared Thermometer – MLX90614	1	1099
MFRC-522 RFID Module	1	188	MFRC-522 RFID Module	1	188
LED - 5mm	10	1.61	LED - 5mm	10	1.61

Raspberry Pi Camera 8MP,1080p	1	2987	Raspberry Pi Camera 8MP,1080p	1	2987
Female To Female Jumper Wires (40)	1	50	Female To Female Jumper Wires (40)	1	50
Male To Female Jumper Wires (40)	1	50	Male To Female Jumper Wires (40)	1	50
Lodestar Soldering Iron - 60W	1	322	Lodestar Soldering Iron - 60W	1	322
Soldering Iron Stand	1	96	Soldering Iron Stand	1	96
Micro HDMI to Standard HDMI Cable	1	398			
Sub Total:		₹ 21,850	Sub Total:		₹ 13,825
Miscellaneous Cost		₹ 150	Miscellaneous Cost		₹ 175
Total Budget		₹ 22,000	Total Budget		₹ 14,000

#### 4.4 Performance evaluation of developed solution

The system 2 is the optimal design that we have chosen while started to move forward in the project completion. After the completion of the project the test runs and the different case evaluation gave out a lot of performance data which are as follows.

##### 4.4.1 RFID Detection

The performance metric for the RFID detector module is mainly the effective read range. According to the documentation the distance is 3cm which is pretty standard for an authentication system. The detection time is very fast, almost instantons. So, there is no time loss in this part of the entry process.

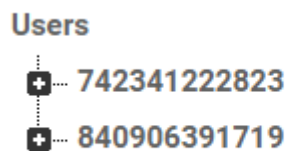

Fig.9 RFID UID log on firebase

#### 4.4.2 Face-mask detection

The training accuracy of the face-mask detection system was very satisfying as that gave out some compelling accuracy level of the detection process.

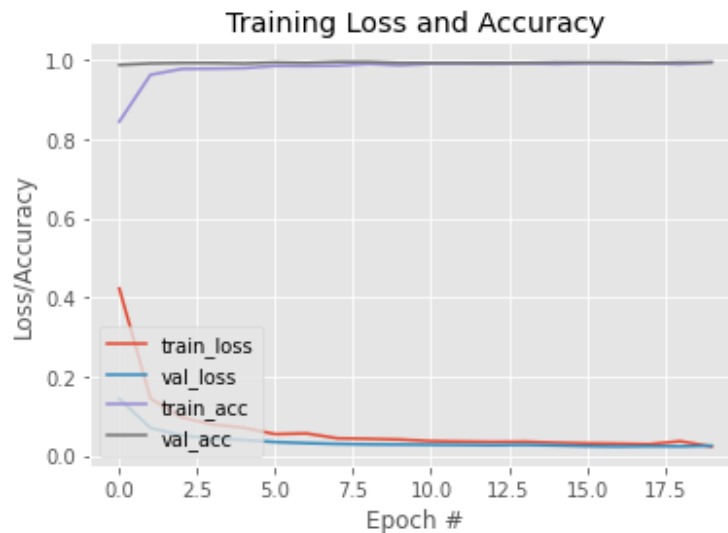

Fig.10 Facemask Training Loss and Accuracy

```
[INFO] evaluating network...
          precision    recall  f1-score   support

  with_mask           0.99      0.99      0.99         383
  without_mask        0.99      0.99      0.99         384

   accuracy                   0.99         767
  macro avg           0.99      0.99      0.99         767
  weighted avg        0.99      0.99      0.99         767

[INFO] saving mask detector model...
```

Fig.11 Face Mask detector model accuracy

Finally, the approximate detection time is 10 seconds in first run and the face detection file imports heavy packages such as OpenCV, TensorFlow, Keras etc. From the second loop run the detection time gets lower even more as it doesn't need to load all the packages every time.

#### 4.4.3 Temperature sensor

The documentation data and the real usage performance data differs from each other in terms of MLX90614 temperature sensor as the fluctuation is very visible with the positioning of the target object.

TABLE V Documented and real usage data comparison

Distance	Documented Accuracy	Real usage accuracy
.5 cm	$\pm 0.1^{\circ}$	$\pm 0.1^{\circ}$
1 cm	$\pm 0.1^{\circ}$	$\pm 0.1^{\circ}$

#### 4.4.4 Oxygen saturation

SpO2 sensor is being used to measure the blood oxygen saturation level. This particular sensor very much sensitive to the interference of external light. This sensor needs time to calculate the value to give it as an output as it uses a buffer method to analyze the data. So, the approximation of 15 seconds was made to get the most accurate result. The result accuracy fluctuates the time for this sensor, the observation that we have made was:

TABLE VI SpO2 Sensor Data Characteristic

Time	Actual Blood Oxygen Saturation Level	Real Usage Accuracy
15	98%	$\pm 1\%$
20	98%	$\pm 1\%$

#### 4.4.5 Data collection to Realtime database

The collected data are instantaneously sent to the cloud server as the used platform is Firebase Realtime database system, the integrity of the system is very rigid.

- The data transfer depends on the stable internet connection.
- Data transfer to the cloud server takes about 20 seconds give or take.
- The free user data collection limit is 1GB.

#### 4.5 Conclusion

Finally, it can be said that from all the optimization information and evaluation the optimal design is the 2<sup>nd</sup> system that we designed. The performance data clearly backs the decision of choosing that as the optimal device. Unfortunately, some of the sensor data are not as aligned with the specified documented data which was a letdown. But the simple tweak of the system easily can diminish that problem.

## **Chapter 5: Completion of Final Design and Validation.**

### **5.1 Introduction**

The overall design of the system was completed between the middle of EEE400D and the conclusion of EEE400C, allowing us to complete the system's final design to our specifications. We dealt with a lot of systemic and theoretical issues, and we performed a lot of troubleshooting to figure out what the key issues were and come up with practical solutions to support our argument.

### **5.2 Completion of final design**

At the initial stage the design was a methodology-based flowchart with the implementation of the algorithm that we want to use in this project. Then to complete the device we needed to collect resources regarding the hardware components and design the schematic to setup the whole system.

Initially we started with building up the system block by block, more clearly, we progressed by sensor-by-sensor approach. After completion of all the sensor's individual implementation it was time to bring the whole thing under an embedded system so that the whole process works sequentially and simultaneously. To make the device as a whole the programming part was the key, that alone binds the whole system together to operate as a whole.

### 5.2.1 System's logical diagram

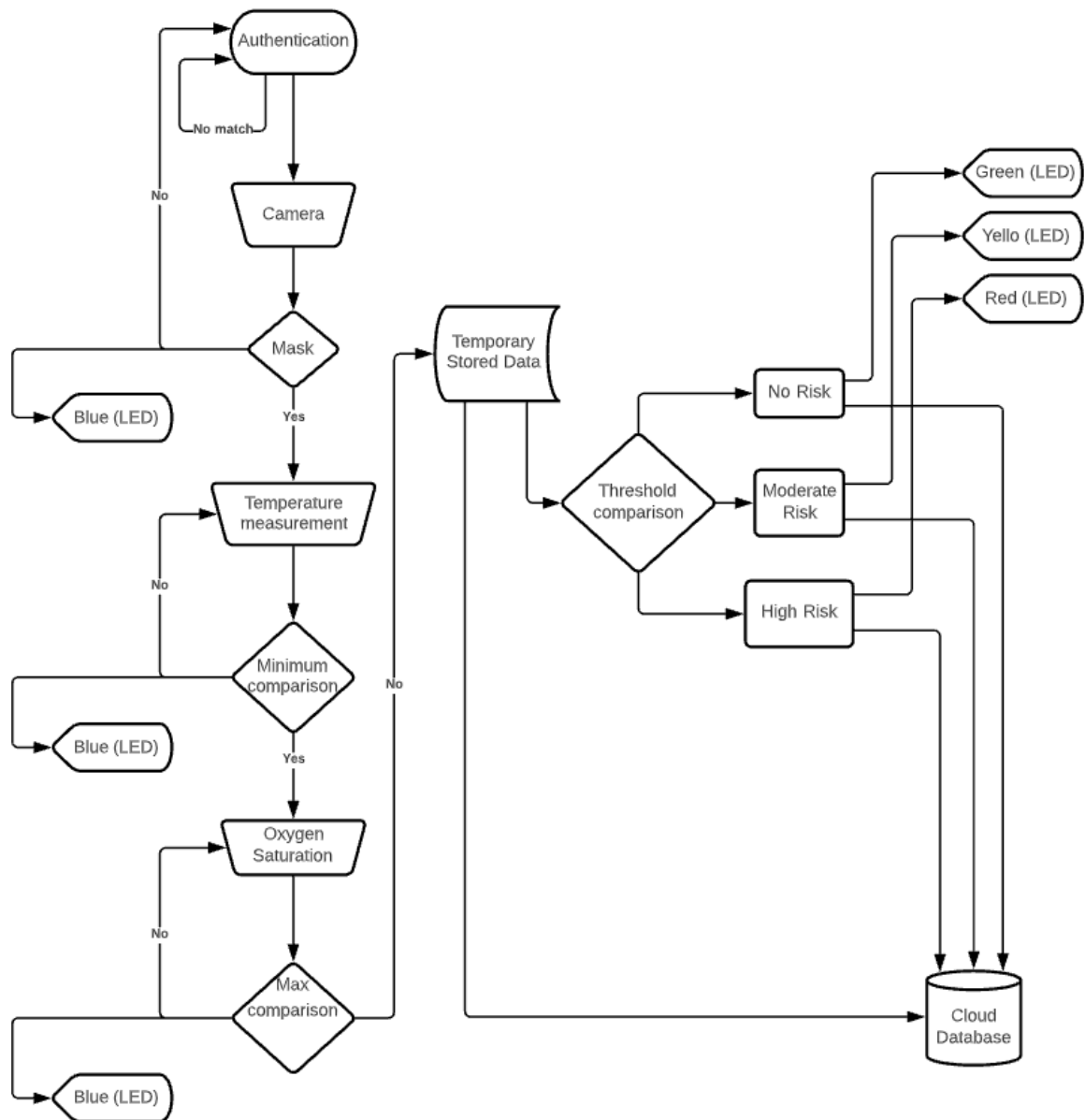

Fig.12 Optimal design's logical diagram



## 5.2.2 Final design schematic

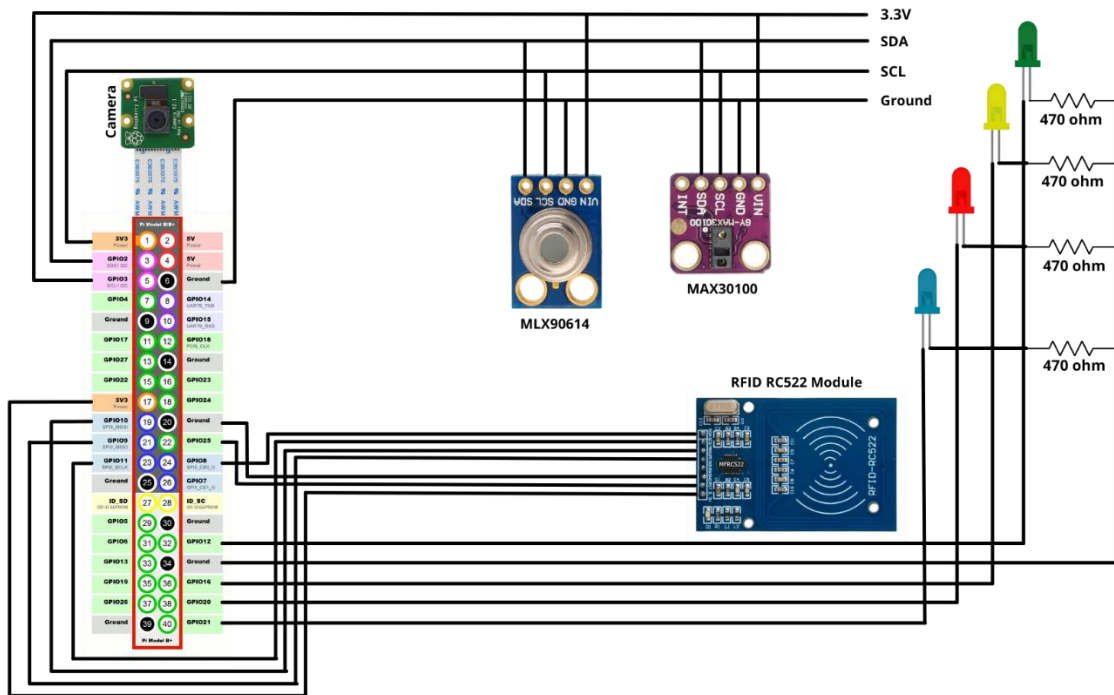

Fig.13 Circuit connection schematic

## 5.2.3 Final device

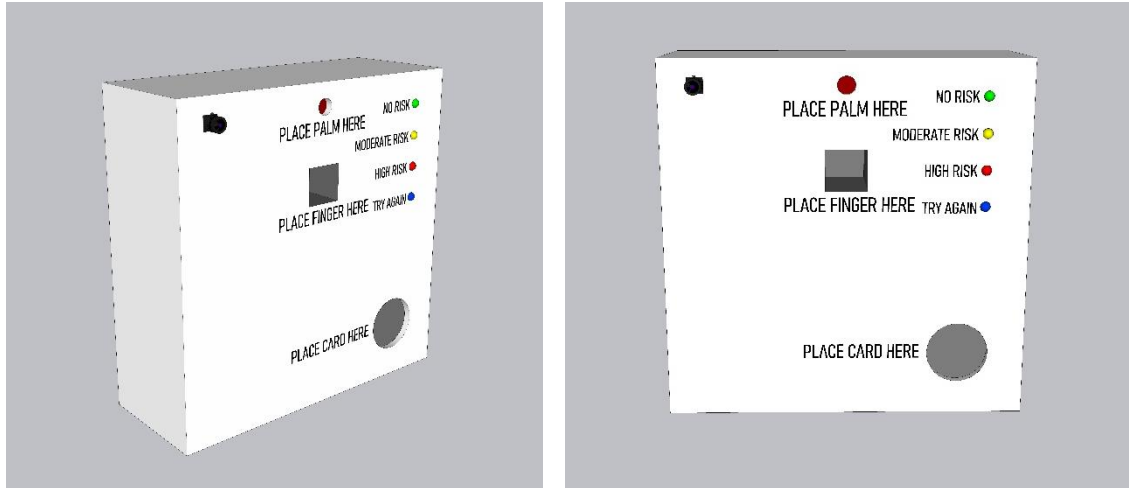

Fig.14 3D render of the final device

### 5.3 Acquired Dataset from the system:

TABLE VI System Output data

Date	Time	Subject Name	RFID UID	Face-mask	Temp	Oxygen saturation	Risk factor	Check-up Duration (Seconds)
Jan-05-2022	19:42:47	Rubaiyat Alam Ruhin (18121067)	703641 043057	Yes	97.918F	97%	No Risk	41
Jan-05-2022	19:43:47	Rubaiyat Alam Ruhin (18121067)	703641 043057	No	n/a	n/a	n/a	n/a
Jan-05-2022	19:44:51	Rubaiyat Alam Ruhin (18121067)	703641 043057	Yes	98.386F	96%	No Risk	38
Jan-05-2022	19:45:33	Rubaiyat Alam Ruhin (18121067)	703641 043057	Yes	98.146F	98%	No Risk	35
Jan-05-2022	19:57:20	Rubaiyat Alam Ruhin (18121067)	703641 043057	Yes	99.554F	98%	Moderate Risk	35
Jan-03-2022	12:40:00	Tahsin Muhtady Mahi (18121005)	840906 391719	Yes	102.162 F	99%	Moderate Risk	38
Jan-03-2022	12:44:24	Md Hasnatul Amin (18121107)	700746 252415	Yes	97.918F	97%	No Risk	35
Jan-01-2022	15:49:26	Tasnimul Hasan Efty (18121123)	635558 248464	Yes	98.654F	99%	No Risk	41

Jan-01-2022	15:52:30	Rafid Areman Ayon (18121086)	622756 377201	Yes	97.637F	99%	No Risk	38
Jan-01-2022	15:55:24	Syed MD. Jawadul Alam (18121064)	620995 162630	Yes	98.978F	98%	No Risk	50
Dec-27-2021	16:47:47	Mohimin-Al Bhuiyan (18121100)	620116 193805	Yes	99.518F	95%	Moderate Risk	35
Dec-27-2021	16:49:05	Farhan Hasin Khan (18121072)	564268 187811	Yes	98.134F	100%	No Risk	35
Dec-27-2021	16:50:21	Aminul Islam (18121007)	231229 500051	Yes	98.234F	96%	No Risk	41
Dec-27-2021	16:52:12	Irfanul Arefin (18121122)	229160 528460	Yes	98.042F	95%	No Risk	35

So, we can see that from the acquired data, the overall sum up that have we came to is total subject was 10. The average check-up time was 38 seconds. The risk factor that we had encountered is No Risk = 8, Moderate Rank = 2, High Risk = 0. At the beginning of the testing, we took data from same person multiple time to check out the data consistency. It checked out.

#### 5.4 Evaluate the solution to meet desired need

The optimal system design that we have chosen is delivering the objectives that we were expecting in efficient and effective, just how we anticipated.

##### Accurately authenticating users

As this is an entry system, our first and foremost objective was to make the system identify the students/employees or particular institution/office so that no unauthorized personnel can get into the building. With the RFID verification we are successful to distinguish between the authorized and unauthorized personnel as the integrated RFID module will not read data from unauthorized card, hence the system will not move forward with the checkup sequence.

##### Precisely detecting face-mask

No-a-days wearing face mask has become a mandatory precautionary measure to save thyself and also for the good of other people as it helps to minimize the spread of virus a great deal. The use of face mask is personal choice, so everyone should wear a mask. That is why in our

system the sequence will not move forward if it doesn't detect any mask on a face, because wearing a mask is very much controllable by our will. So, the system will not let a person get inside without wearing a mask.

### **Accurate temperature data collection**

We have already acknowledged the temperature sensor's accuracy which is very precise in this kind usage. So, the sensor will take temperature of the user's wrist to determine the level of risk they are in. [8]The wrist temperature is being taken rather than the forehead is because it is much more accessible and user friendly, also the wrist temperature's mean difference is  $-0.96^{\circ}\text{C}$  to  $-0.61^{\circ}\text{C}$  and the high fever screening success rate of wrist temperature is 95% according to studies which is equals to the forehead temperature's success rate.

### **Accurate SpO2 data collection**

The light interference was a huge factor in SpO2 data fluctuation. But the final product will be inside an enclosed box which will ensure no light interference to the sensor, so the data will be accurate as the datasheet claims.

### **Systematic work of data manipulation and output indicators**

The deliverance of a result to the users is the most important part of a project. So, after collecting all the data from a user, the system will use the data and run it through a dynamic decision algorithm to determine the risk level of the particular user.

The result of the risk level will be conveyed with the use of LEDs. As there can be 3 outcomes.

- No Risk                    - Green LED
- Moderate Risk        - Yellow LED
- High Risk                - Red LED

In this manner the LEDs will indicate the user of their risk level.

### **Seamless real-time data storage**

The system that we are developing is very much data driven. This data is very import to measure the risk level in Realtme, also these data can be used to track the health condition of a user to make prediction which can come in handy in future.

### **Budget limit**

Creation of any complex engineering device needs research and development. The budget allocation for a newly developed system has to be always higher than the already established one as there are always some risk factors while trialing new things. So, after the total development and evaluation of the system it can be said that the lower bound of this particular project should not be exceeded, in that case the system might not operate as expected as certain standard of components are needed to get the best result out of this system.

## **5.5 Conclusion**

As a result, we may infer that the system we want to construct meets all of the requirements we established earlier. From the research till the development, the high integrity of the system was always the main priority as this project is related to health protocol. Any indiscipline may cause harm to people's health, which will ruin the core objective of this particular project. So, multiple tests have been done on the system to evaluate the system integrity and the characteristic and in which condition it works best.

## **Chapter 6: Impact Analysis and Project Sustainability.**

### **6.1 Introduction**

The Coronavirus, which originated in Wuhan, China, has already spread around the globe. This Pandemic has impacted millions of individuals worldwide. And we are 1 and a half year+ into this devastating pandemic. And we are 'somehow' dealing with a worldwide health crisis unlike any other in the previous century. We're still reliant on covering our faces and monitoring our temperature and oxygen saturation. Vaccines, on the other hand, are now available, providing some level of resistance to the spread of this devastating illness. They aren't been proved to be 100 percent effective against all Coronavirus variant[9]. So, it is critical that this project thoroughly examines all of the pandemic's critical components. During this epidemic, the most important thing for everyone to do is stay safe and avoid random human contact. Even still, many individuals are obliged to go outdoors and work in order to make a livelihood. With keeping this crisis of a situation in mind, we are developing this project to ensure their health and safety at work. While obtaining the desired result, we will undoubtedly notice some crucial impacts in many different aspects of our lives

### **6.2 Assess the impact of solution**

As we are developing a system which will create a safer workplace during a pandemic. For this reason, our project will have a huge impact on different scenarios in our day-to-day life i.e., the spread of the virus will reduce drastically as we will separate the healthy people from the people who has symptoms of covid and also make sure that people have taken proper precautions. Some of the impacts are as follows:

#### **6.2.1 Social impact**

The component of societal acceptability, justice, and effect of any specific machinery or new creative ideas/technologies that will lead to a higher quality of life is referred to as social impact. Because the proposed initiative is so fresh, confidence and acceptability may be one of the most important societal factors. However, numerous types of devices are already in use to monitor various health factors, but none of them are linked as a system, nor are they especially cost efficient. As a result, it's understandable that individuals will be cautious to use our proposed project at first. So, a great deal of confidence and public knowledge should be created in order to obtain societal acceptability. With our designed project we are confident to achieve the positive impact on society.

#### **6.2.2 Health impact**

This approach would aim to protect every confined compartment from the SARS-COV2 infection as much as feasible. And, because our initiative will directly involve the human body, health issues will surely arise. As showed in our design, we used effective equipment, tested sensors, and proper safe environment so it omits any possible hazardous effects on health. As we will be extensively analyzing the output of our system, any potential health concerns about its users' health will be emitted.

### **6.2.3 Legal impact**

We are being extremely cautious and cautious about any legal implications till we begin the design phase of our project. However, it is critical that the privacy concerns of our system's users are addressed. Institutions that use our suggested system will be responsible for maintaining this. Also, it won't have any legal consequences pertaining to environmental legislation. We as a group have devised and suggested a method that would not harm our environment but will instead contribute to its improvement and we will be maintaining this throughout the timeline of this project.

### **6.2.4 Safety impact**

In terms of safety, our project's major goal is to establish a "safe" atmosphere in terms of health, free of COVID-19 risks. Till the recent progress in our designing, we have used proper wiring to eradicate any possible harming aspect from our project. Before the project is completed, more safety concerns will be addressed. As we haven't used our system to its full potential, we are yet to see any complications regarding any component failing to provide desired result. While trying to design the project to get the most optimum result we have made some changes in terms of safety. UV light in oximeters were difficult to construct as it was exposing human skin directly to wires. So, we excluded that part. We hope to address more safety impacts of this work in coming semester.

### **6.2.5 Cultural impact**

Social distancing policies have the greatest impact on venues-based industries (such as museums, performing arts, live music, festivals, movies, and so on). The sudden reduction in revenues has put their financial stability in jeopardy, resulting in lower wage earnings and layoffs, with ramifications for their value chain of suppliers, both creative and non-creative. Our initiative, with the designed solution we are offering, will have a significant influence on these industries' ability to work on a fulltime manner. In terms of our workplace culture, our improved project will be helpful to gain workers' trust as they will be working in a safe environment protected against potential coronavirus carriers. And as we are closely heading towards reopening all educational institutes, parents will feel more confident sending their son/daughter to their respective institutions if they see a safe, healthy environment is being ensured through our designed project.

## **6.3 Evaluate the sustainability**

We have proposed a system that will help us fight against Covid-19. So, we have to ensure that the system follows the economic, environmental and the social norms and guidelines. Also, we have to maximize the sustainability to ensure the maximum safety of the people.

### **6.3.1 Quality of the system**

The parts used in the project we used should be chosen carefully. If they are not chosen carefully, the system may not run properly or may perform poorly. In the project, we have considered all the cost factors and the most effective factors and chosen the most optimal parts so that the system runs smoothly and efficiently. Moving on, Covid-19 is a highly infectious disease and it can spread in a very high rate if precautions are not taken properly.

The project we have proposed is used to prevent Covid-19 affected people from entering public places. So, if the parts of the system are not chosen carefully it may affect a lot of people. The parts we have chosen for our project consists of parts which will do the job and is also efficient.

### **6.3.2 Repair and maintenance**

The performance of the project we proposed can be affected by air pollution if not treated properly. The components we are using should be cleaned at least twice a day not because of the pollution but also because this can also be the reason of spreading the virus if not treated properly. Moreover, A technically sound personnel should treat the system because if not repaired properly, the project may malfunction which may cause human casualties.

### **6.3.3 Human Resource Management**

The project we proposed helps a lot of people with their time, money and manpower. As mentioned before, the corporate offices, educational institutes and factories had to keep a man to check the necessities but after implementing this project, they do not have to keep an extra man for this job. They can utilize that manpower somewhere necessary.

### **6.3.4 Safety and Security**

The safety of our lives is threatened by Covid-19 for a long time now. We have to take precautions and be aware if we have any symptoms or not. The project we proposed ensures the safety and security of our lives as it monitors if a certain person has any symptoms by checking their Temperature, Pulse and Oxygen level in their blood. It also monitors if the person has taken the necessary precautions or not. Moreover, the parts we have used it Contactless except the pulse oximeter, but to ensure the e oximeter to be sterilized, we are sanitizing it with UV light constantly. As this is mostly a contactless system and we are continuously sterilizing the parts which need contact, we can say this ensures the safety and security of our lives.

### **6.3.5 Cost and time efficiency**

Most of the corporate offices, educational institutions and factories recently had to use a man who checked if the person entering has any symptoms or taken necessary precautions. This way they had to pay a good amount of money. The project we proposed can do the exact same thing quickly and more accurately. Moreover, the project is a one-time payment job since the owner doesn't have to spend a good amount of money after the system every month.

### **6.3.6 Public Awareness**

Covid-19 has been around for more than a year now and some steps were taken to prevent this virus from spreading. The project we proposed is relatively new but people can use the components we are using in our system i.e., the camera, the thermometer and the pulse oximeter. Therefore, with a few instructions, demonstration and training campaign, public awareness can be achieved. The government or the authorities should arrange these demonstration and training campaigns so that more people get to know about the project and how to use it.



## **6.4 Conclusion**

During this pandemic, people cannot go to their work station without worrying about getting infected. With the help of our project, the people can at least be at a little relief at work. Not only that, we can see that the system can have a huge impact on different scenarios.

## **Chapter 7: Engineering Project Management.**

### **7.1 Introduction**

The method of planning, planning, executing, managing, and concluding the work of a team in order to achieve certain goals and satisfy defined success criteria within a given time frame is known as project management. The major difficulty of project management is to meet all of the project's objectives within the schedule and budget limits. A project manager is the level of leadership that plans, budgets, coordinates, supervises, and oversees the operational contributions of property experts and others in a project involving land development in line with a client's quality, cost, and time objectives. Our initiative focuses on issue solutions from an engineering standpoint. Engineering Management is the combination of engineering and management abilities with technical competence to coordinate work in numerous technical sectors, including inter-disciplines and external interfaces, as well as to address technical challenges and problems. Engineering Management is concerned with the application of engineering concepts to the optimal planning and operation of resources and technology.

### **7.2 Define, plan and manage engineering project**

From the beginning to the finish, the project used both qualitative and quantitative methodologies. This project's research is focused on interviews and surveys, and its main aspects are conception, definition, planning, execution, monitoring, control, and finalization. This is because individual activities and their outcomes are measured subjectively, whereas the duration of each activity is quantified. This prompted us to launch a project to address one of the most critical problems during the COVID 19 epidemic. So, during our initial phase of the research we have found out that entering any restricted facility, such as an office building, a university building, or an airport, requires a basic health routine check in accordance with WHO guidelines (World Health Organization). Basically, we check the masks and body temperatures of anybody who wants to enter. However, investigations have shown that simply screening for fever is insufficient to assure protection from the coronavirus that causes the disorders. And we discovered that many businesses and offices are having difficulty addressing this issue adequately. As a result, we have devised an embedded system method to this problem that will help this significant problem for the conceivable future.

#### **7.2.1 Project definition**

A project is a temporary endeavor undertaken to produce a one-of-a-kind output, which can be a product or a service. The term "temporary" does not often apply to the project's product, service, or result. The majority of initiatives are done with the goal of producing long-term results. The coronavirus, which was found in Wuhan, China, has already spread over the world. This Pandemic has reached epidemic proportions throughout. And we're still coping with this devastation for almost 2 years. We are somehow dealing with a global health catastrophe unlike any other in the last century. This virus is dangerous not because it is lethal, but because it is extremely contagious. Even passing close to an infected person for a few moments can infect a human. The primary goal of this project is to determine whether or not a person has taken precautions or has symptoms. To accomplish this goal, we have created four sub-goals to achieve our main objective. From the initiating stage from EEE400P till the closure of the

project, we have followed a set of principles to reach our intended output from our final year design project.

### **7.2.2 Project planning**

Project planning is a subset of project management that comprises utilizing schedules such as Gantt charts to plan and then report progress within the project environment. It involves identifying details of tasks to be performed during the project and charting out the sequence and schedule of required activities and allocation of resources, time and money to each stage of the project. The project scope is first determined, and the essential methods for project completion are chosen. If a project does not have an adequate strategy in place, it may face the following hurdles:

If a project lacks an adequate strategy, it may face the following challenges:

- i. Project Delays
- ii. Inaccurate Project Completion
- iii. Team Misunderstandings.
- iv. Poor Communication
- v. Poorly defined goals and objectives

So, in EEE400P, we have presented our first project plan, which comprises all actions required to identify, integrate, and coordinate all subsidiary and complementary plans into a unified project management plan. The outline portrayed how the project will be carried out, monitored and supervised, and completed. However, the management plan is being updated and improved in various aspects of project design and implementation. In the first semester of our final year design project, we presented our project subject and discussed the next outline of the project timetable. Choosing a project topic and analyzing the project's timeframe proved to be difficult. We have been facing issues since we are one person short of the needed number of participants for an FYDP. It was difficult to divide the task for the background research. Because of the manpower scarcity, we were unable to perform the project we had planned to complete earlier. This issue caused us problems and exposed us to several hurdles during the endeavor. Furthermore, it was challenging to blend opinions, ideologies, and ideals of each team member because everyone on the team had a distinct attitude. During this step, we also assessed the viability of our proposal. It is a review and evaluation of the viability of a new project or system that focuses on technical feasibility and commercial profitability. The Feasibility Study considers legal, economic, technological, cost and schedule, environmental, and other considerations leading up to the project's completion, as well as commercial activities.



TABLE VIII Responsibility representation of EEE400P

Tasks	Distribution
Project proposal and Planning	Everyone
Proposal report	Rubaiyat Alam Ruhin - Specification and requirements, Methodology, Project plan, Budget and Expected Solution.
	Aminul Islam - Impact, Ethical considerations, Risk management and analysis, Applicable codes and standards
	Tahsin Muhtady Mahi - Problem statement, Background research, Scope and Objectives, Sustainability, Safety considerations.
Component selection	Rubaiyat Alam Ruhin - Face mask and RFID
	Aminul Islam - Pulse Oximeter
	Tahsin Muhtady Mahi - Thermometer
Slide Design	Rubaiyat Alam Ruhin

### 7.3 Evaluate project progress

Our project proposal included all of the time-sensitive goals. However, owing to unforeseen circumstances, the commencement of the project's design component was delayed. Due to the country's COVID lockdown stages, our component purchase was postponed indefinitely. We also had difficulty locating a location to carry out our proposed design. This will be covered in further detail in the following portion of the chapter. In terms of project progress, we have divided this portion in 2 categories –

#### 7.3.1 Project Designing

Various system design possibilities are assessed during the conceptual design phase, and parameters with the greatest influence on project implementation are finalized. These include significant system/equipment design, energy saving measures, system optimization, and degree of plant automation, maintenance and flexibility requirements, and future expansion planning, among others. During the system design of our project, we worked on this target. We implemented the original project design using software simulation and numerous design techniques. In the first half of EEE400D, we have presented a Proteia-based simulation file of our project to our ATC panel. Then while doing the multiple design approach we ran into various difficulties. Due to the fact that this project is entirely self-funded. We faced greater financial hurdles than ever during this phase since we had to choose a new on-board computer to build the system. There were also several different approaches to the additional sensors and components. Further, due to funding constraints, we were unable to complete a full multiple design approach. Multiple hardware components were scrapped due to functional shortcomings. In this phase, one of our team members was ill with dengue fever, costing us time and delaying the total time for designing the best solution for our project. As a result, the other two members have been in charge of the entire design process for quite some time. All these issues have constantly changed our project plan. However, during this time, one of



TABLE X Responsibility representation of EEE400D

Tasks	Distribution
Design Planning	Everyone
Design Report	<b>Rubaiyat Alam Ruhin</b> - Multiple design approaches, Selection of modern IT tools, Functional verification of multiple design solutions, Analyze the multiple design solutions to find the optimal solution.
	<b>Aminul Islam</b> - Project plan, Budget, expected impact and solutions, Project plan, Ethical consideration, Report summary
	<b>Tahsin Muhtady Mahi</b> - Background research and survey, Objectives, Specifications, Requirements and constraints, Risk management and contingency plan.
Design and component selection	<b>Rubaiyat Alam Ruhin</b> - Face mask and RFID
	<b>Aminul Islam</b> - Pulse Oximeter
	<b>Tahsin Muhtady Mahi</b> - Thermometer
Component procuring	Rubaiyat Alam Ruhin
Slide Design	Rubaiyat Alam Ruhin

### 7.3.2 Project Execution

The execution phase is the final stage of our project management lifecycle, and it has been the most time-consuming. Throughout this time, we have been consistently trying to develop our product and subsequently deliver it to the client. We started the principal design and execution stages of our project this semester (EEE400C). We're nearing the conclusion of the semester, and our project has been done satisfactorily. As previously stated, the face mask detection part of the project was finished earlier in the semester (EEE400D).

Delays in component procurement, as well as illness among certain team members, slowed the project's early development. However, during the previous three months, we have put in a lot of work to complete the project. And we've finalized our project. As we began working on the hardware implementation before EEE400C started. We have worked in 4 divisions –

- i. Raspberry Pi installation and integrating
- ii. Sensor integration for temperature and oxygen saturation
- iii. System integrating and data collection
- iv. Report Writing

However, certain issues still occurred in this phase. Parts I and II were assigned to Ruhin and parts III and IV were done by Mahi, Aminul and Ruhin together. Certain hardware components such as the LCD panel, oximeter sensor came out faulty and we had to order them multiple times. The riskiest part was the soldering part. We didn't have any prior expertise with such work, so we had it done by a repair shop. Later on, we did face some issues with hardware scarcity. It was difficult to run the system with one single PC. To figure this out, we had to utilize two displays and a keyboard at the same time. In terms of

connecting every sensor and making the system work was a big challenge as multiple times we did not get the connection part right. Multiple attempts solved this issue. Furthermore, we had heating issues while running the raspberry pi over a longer period. After 3-4 hours of usage, it was getting warm so we did not keep it functioning for a longer period. This is a cause for worry because our major objective is to use this project in a full-time working environment. We also faced sensor lag issues. All of us have been working on the report writing section at the same time. Due to earlier delays, we have also passed the ATC final report submission date. We did, however, complete our final report before the authorized EEE400C deadline.

TABLE XI Responsibility representation of EEE400C

Tasks	Distribution
Design Planning	Everyone
Design Report	<b>Rubaiyat Alam Ruhin</b> - Identify Multiple design, Analysis of multiple design approach, Selection of appropriate engineering and IT tools, Optimization of multiple design approach, Identify optimal design approach, completion of final design and Validation.
	<b>Aminul Islam</b> - Define, plan and manage engineering project, Project planning, Project Designing, Project Execution, Cost benefit analysis, evaluate economic and financial aspects, identify ethical issues and professional responsibility, apply ethical issues and professional responsibility, Project summary, Identify the attribute of complex engineering problem,
	<b>Tahsin Muhtady Mahi</b> - Problem statement, Background study, Literature review, Literature gap, Objectives, Requirements, Specifications, Constraints, Cost effectiveness, Impact analysis and Project sustainability, Economic analysis,
developing and research	<b>Rubaiyat Alam Ruhin</b> - Face mask and RFID, Pulse Oximeter, Thermometer.
	<b>Aminul Islam</b> - Pulse Oximeter
	<b>Tahsin Muhtady Mahi</b> - Thermometer
System assembling	<b>Rubaiyat Alam Ruhin</b>
Slide Design	<b>Rubaiyat Alam Ruhin</b>

## 7.4 Conclusion

Project Closure: Notwithstanding all of the obstacles and challenges, we were able to complete every milestone we proposed earlier. As discussed above, lack of strategy could have resulted in inaccurate project completion. During the overall project management cycle, we worked as a team, we addressed all the challenges by trial and error with the system, as well as through strong communication and solid understanding, in order to reach our desired objective. We experienced significant project delays throughout the project cycle, yet we kept a keen eye on our goals. We took an iterative and agile approach to development and prioritized specific features, allowing us to complete a minimum-viable product in the time frame allotted. Risk



management and dependencies of the project were some key issues that we sought, identified and solved as a team. Thus, we have been able to prevent a number of unforeseen issues. Through tracking and monitoring, we were also able to regularly update and adjust our project schedule. Tracking entails reconciling the project plan with the project's actual progress. Our ATC panel has also been monitoring the situation on a weekly basis. This aided us in bringing the project to fruition.

## Chapter 8: Economical Analysis.

### 8.1 Introduction

Economic analysis of projects will support decision making in investment of resources. When we decide to make a large investment in a future activity that entails risks of damage, whether known or unanticipated, we must be concerned about the danger of losing our own property. By evaluating cost and benefit, economic analysis will provide information on the most effective and efficient investment option.

### 8.2 Economic analysis

We have designed an IoT Based Automated Entry System with Health Protocol Implementation. Though the budget for the prototype that we developed is essentially a low-budget project, in the real-world scenario, the budget will increase with some additional tuning and developments. The total cost scenario for the prototype we have recently developed for our final year design project is presented below –

TABLE XII Complete Component Budget of The Project

Components Name	Unit Price in BDT (₳)	Quantity	Web Link
Raspberry Pi 4 Model B 4GB	7,500	1	<a href="https://www.techshopbd.com/detail/3430/Raspberry_Pi_4_Model_B_4GB_techshop_bangladesh?numberOfCartProducts=0">https://www.techshopbd.com/detail/3430/Raspberry_Pi_4_Model_B_4GB_techshop_bangladesh?numberOfCartProducts=0</a>
Micro HDMI to Standard HDMI Cable	398	1	<a href="https://www.techshopbd.com/detail/3453/Micro_HDMI_to_Standard_HDMI_Cable_techshop_bangladesh?numberOfCartProducts=0">https://www.techshopbd.com/detail/3453/Micro_HDMI_to_Standard_HDMI_Cable_techshop_bangladesh?numberOfCartProducts=0</a>
Transcend Microsdxc/sdhc 300s 32GB Memory Card	625	1	<a href="https://www.techlandbd.com/accessories/memory-card/transcend-memory-card/transcend-microsd-300s-32gb-memory-card">https://www.techlandbd.com/accessories/memory-card/transcend-memory-card/transcend-microsd-300s-32gb-memory-card</a>
MAX30100 Finger Oximeter Heart Rate Module	500	1	<a href="https://bdspeedytech.com/index.php?route=product/product&amp;product_id=2594&amp;search=MAX30100">https://bdspeedytech.com/index.php?route=product/product&amp;product_id=2594&amp;search=MAX30100</a>
Infrared Thermometer – MLX90614	1099	1	<a href="https://store.roboticsbd.com/sensors/307-mlx90614-contactless-temperature-sensor-module-for-arduino-robotics-bangladesh.html">https://store.roboticsbd.com/sensors/307-mlx90614-contactless-temperature-sensor-module-for-arduino-robotics-bangladesh.html</a>
MFRC-522 RFID Module	188	1	<a href="https://www.techshopbd.com/detail/2218/MFRC522_RFID_Module_techshop_bangladesh?numberOfCartProducts=0">https://www.techshopbd.com/detail/2218/MFRC522_RFID_Module_techshop_bangladesh?numberOfCartProducts=0</a>
LED Red - 5mm	1.61	10	<a href="https://www.techshopbd.com/detail/291/LED_Red_5mm_techshop_bangladesh?numberOfCartProducts=0">https://www.techshopbd.com/detail/291/LED_Red_5mm_techshop_bangladesh?numberOfCartProducts=0</a>
Raspberry Pi Camera 8MP,1080p	2987	1	<a href="https://www.techshopbd.com/detail/2725/Raspberry_Pi_Camera_V2_techshop_bangladesh?numberOfCartProducts=0">https://www.techshopbd.com/detail/2725/Raspberry_Pi_Camera_V2_techshop_bangladesh?numberOfCartProducts=0</a>

Female To Female Jumper Wires (40)	50	1	<a href="https://bdspeedytech.com/index.php?route=product/product&amp;product_id=265&amp;search=Female+To+Female+Jumper+Wires">https://bdspeedytech.com/index.php?route=product/product&amp;product_id=265&amp;search=Female+To+Female+Jumper+Wires</a>
Male To Female Jumper Wires (40)	50	1	<a href="https://bdspeedytech.com/index.php?route=product/product&amp;product_id=268&amp;search=Female+To+Female+Jumper+Wires">https://bdspeedytech.com/index.php?route=product/product&amp;product_id=268&amp;search=Female+To+Female+Jumper+Wires</a>
Lodestar Soldering Iron - 60W	322	1	<a href="https://www.techshopbd.com/detail/2616/Lodestar_Soldering_Iron_-_60W_techshop_bangladesh?numberOfCartProducts=0">https://www.techshopbd.com/detail/2616/Lodestar_Soldering_Iron_-_60W_techshop_bangladesh?numberOfCartProducts=0</a>
Soldering Iron Stand	96	1	<a href="https://www.techshopbd.com/detail/10/Soldering_Iron_Stand_techshop_bangladesh?numberOfCartProducts=0">https://www.techshopbd.com/detail/10/Soldering_Iron_Stand_techshop_bangladesh?numberOfCartProducts=0</a>
Sub Total:	৳ 13,825		
Miscellaneous Cost	৳ 175		
Total Budget	৳ 14,000		

To create our project, we studied the market prices of all accessible possibilities and then determined which component would be the most useful not only technically but also financially. We looked in stores and on online websites to make it more cost effective for everyone, so that once this system is released to the market, it will be available to anybody who requires an entrance system with incorporated health regulations.

Our initial approach for the main controlling board was to utilize two Arduino boards with a master and slave algorithm, however this was more expensive. Because running autonomous machinery requires the usage of an Nvidia Jetson computer board in Arduino boards. As a result, we reduced the cost of the controlling board to a single Raspberry Pi 4. We chose a normal 8 MP raspberry pi camera over a more sophisticated camera, such as the Aluratek AWC02F, which is a 1080P webcam for the raspberry pi, since we required a clear image of the individual. We had to maintain the system as contact-free as feasible while designing the sensors.

### 8.3 Cost benefit analysis

A cost-benefit analysis compares the expected or estimated costs and benefits (or opportunities) connected with a project choice to evaluate whether it makes business sense. Previously we have discussed the overall cost of our project. In some crucial aspects we can compare our project's overall cost with the conventional methods for checking mask detection and temperature detection. In terms of minimizing COVID-19 transmission, our method adds another important component to fundamental health protection. The following is an estimate of the cost of using security guards to ensure entrants are wearing masks and verifying their temperatures –

TABLE XIII Cost Benefit Analysis Between Automated and Manual

Manual			Automated System		
Factors	Specifications	Cost	Factors	Specifications	Cost
Salary of a Security Guard	Day and night shift	₹10000-13000(Approx.) (x2)	Device Cost	Completion cost of the whole project	₹14,000 (with all sort of miscellaneous cost)
Pulse Oximeter		₹2000-3000(Approx.)	Maintenance cost	Subscription cost of the database system	- ₹600(2GB/month as these are all numerical data)
IR temperature meter		₹1000-1500(Approx.)		Repairing of the system if any malfunction occurs	- ₹650(in terms of sensor) - ₹2500(in terms of another component)
	Total	₹23000-30500(Approx.)		Total	₹15250-17750

The components that we have chosen are the most cost efficient and effective when compared to the other alternatives, and the total cost of the entire project is nearly as much as our cost, which is roughly 14,000 BDT. However, colleges and other large companies must now engage one or more people to accomplish the same work, which normally costs the owner far more than the cost of the system. Previously, we also compared our system with a different solution approach. The system with binary decision algorithm and Nvidia Jetson developer kit is very capable due to its powerful processing unit. However, the cost is very high to carry on with this system design and we can't even implement machine learning techniques in the main microcontroller as well.

TABLE XIV Available Products

Serial	Name	Price
1	ScanaTemp (Massk Detector with Temperature Scanning) [2]	\$601(BDT 51,692.19)  **Including shipping charge
2	ZKTECO Face Palm Access Control Reader Mask Detection Body Temperature [3]	\$2584.889(BDT 2,22,327.08)  **Including shipping charge

Now, we can also compare with available commercial products on the market. With all of the devices on the market, they all feature certain high-end mask detection and temperature measurement specifications. However, they are considerably more expensive than the manual approach we previously compared. For example, the first product we've mentioned costs approximately \$601 (₹51,692.19 BDT plus delivery). Our device, on the other hand, costs just ₹14,000 BDT right now, with the potential to rise to ₹18-20,000 BDT following certain upgrades with improved algorithms and LED installation. The only reason we looked for similar products on Amazon was because they have not been sold in our country or even made in our country. In terms of comparison, we have portrayed the degree of precision our system has because our product is still in the development phase till it enters a marketable phase. All it takes is a little tweaking to make the whole procedure go a little faster. Better algorithms, which we want to apply in the next part of the development process, will undoubtedly help us achieve this. Although, given that this product will only be utilized at the entryway, current products provide a higher-end experience that is superfluous. That isn't required in all cases. To assess the symptoms effectively and efficiently, our system just checks all of the checkboxes.

To conclude, companies or institutions may rethink hiring employee's labor as well as available products in a more productive location. Implementing a product like the one we've developed and finalized would provide them a far higher return on their investment.

#### 8.4 Evaluate economic and financial aspects

From these calculations, we can see in this project constructing that, while the initial cost for establishing this hardware configuration is far lower than engaging human labor for the intended goal.

So, from all perspectives and calculations, the entire money that the solar pump would save is ₹ 14,000, but if we include the tax and other terms, the whole currency estimation in this context will be approximately ₹ 18000-20000, which is still less than the typical approach of having security guards. And for the system with Arduino Uno and Nvidia Jetson kit the cost is 22,000 taka which is very expensive considering the fact that both of the systems show similar sort of accuracy.

## **8.5 Conclusion**

As we all know, the project that we are essentially constructing is an original and unusual technology-based project, and making it a viable one was one of the most critical aspects that we had to keep in mind. As a result, we concentrated primarily on electronic automated systems that would ultimately be able to save an appropriate amount of money. Based on the calculations and estimates that we have already made, we can conclude that if we can correctly deploy this project on a wider scale like in actual workstations, it would undoubtedly save the company and institute owners a significant amount of money.

## **Chapter 9: Ethics and Professional Responsibilities.**

### **9.1 Introduction**

Individuals trained in engineering are granted certain benefits by society, one of which is the ability to apply their education to purposeful and respected work. Engineers, on the other hand, have ethical devotion to a variety of contributors in society. Engineering professional responsibility encompasses the ethical accountabilities of engineers in their professional relationships with clients, employers, other engineers, and the public. Honesty and integrity in professional work, confidentiality of proprietary knowledge, collegiality in mentoring and peer review, and, above all, the protection and health of the public are all responsibilities of engineers, since their actions have a direct impact on society and the community.

### **9.2 Identify ethical issues and professional responsibility**

Identifying and tracking all the ethical and professional responsibilities has been one of the most prioritized aspects of this projects' completion. We can identify two perspectives in defining Professional Engineering ethics and responsibilities. These are -

- i. Engineering ethics and responsibilities throughout project design and completion
- ii. Product launching and marketing ethics & responsibilities

### **9.3 Apply ethical issues and professional responsibility**

Firstly, in terms of professional engineering ethics, engineering ethics is a collection of principles and standards that engineers must follow as a moral commitment to their profession and to the rest of the world. Engineering is a professional occupation that has a significant influence on people's lives. When ethics is not followed, disasters arise; these disasters not only have tremendous monetary costs and environmental consequences, but they also frequently result in the loss of human life. Engineering ethics is highly essential and applies to all engineers.

Our work is primarily concerned with the employment of electronic and automated systems in our daily lives during the COVID-19 pandemic. It expands to a branch of engineering that deals with the development of improved electronics. Because our civilization is entering a technological era that will influence all members of society, it is extremely necessary for electrical engineers to adopt a code of engineering ethics. The Electrical Engineering Code of Ethics, issued by IEEE, the largest professional society for engineers working in the disciplines of electrical, electronics, computer engineering, and communications, is an essential set of rules for electrical engineers.

- i. In our project we particularly deal with the people's health factors. So, in accordance with IEEE regulations, we prioritize public safety, health, and welfare in order to adhere to ethical design development processes.
- ii. COVID-19 appears to be an ever-evolving issue in terms of longevity. As a result, our solution will be around for a long time. As a result, our product remains at the forefront of long-term viability.

- iii. In addition, in order to safeguard the privacy of user data, we will provide all of it whenever it is requested. This ensures the data security of all the users.
- iv. Because this is our first project with public health in mind, and we also want to make it profitable, we are willing to receive constructive feedback on our technical work. We are also open to any collaboration and will acknowledge the collaborators' contributions. We've already sent out surveys for recommendations and comments, and we're hoping to keep doing so and incorporating the required changes to make our system better.
- v. In terms of legality, this project is not being carried out in an unlawful manner. It is closely monitored.
- vi. We as a team have developed and suggested a method that would not harm our environment but will instead serve to make it safer. Proper safety measurements have been taken care of in the designing phase of the project. We followed all relevant guidelines while selecting components and on-board processing unit for our system, keeping the overall problem of environmental safety in mind.
- vii. We will also provide a brief guidebook for the corporations who purchase our product in order to prevent any type of injury to the user or damage to any property. Above all, the code promotes transparency and the avoidance of hurting the public or the environment.

Secondly, we are attempting to commercially market our project as a product. We also intend to launch our idea at our university in the near future. There are some professional responsibilities to follow as well. Initially, we have to go through certain administrations, we have to get certain

#### **9.4 Conclusion**

In order to ensure the public's safety, health, and well-being, we endeavored to meet each ethical and professional obligation with the utmost accuracy and attention. As a result, as we move on with the development of our products in the future, we commit to maintain the highest ethical and professional standards and accept responsibility for making decisions that benefit people.



## **Chapter 10: Conclusion and Future Work.**

### **10.1 Project summary/Conclusion**

For over two years, Covid-19 has been preventing the entire planet from working correctly. Because it is extremely contagious and has a high mutation rate. When a new strain of the virus is revealed, the number of people infected skyrockets. During this epidemic, everyone's primary responsibility is to stay safe and avoid random human encounters in person and touch. People are still being compelled to go outdoors and labor in many circumstances to earn a livelihood. As a result, they are continuously travelling to workplaces or shopping centers. Keeping them in mind, we have developed this project to ensure worker health and safety. The primary purpose of our effort is to distinguish possibly infected people from healthy people at the entry level. Using Raspberry Pi, we created, simulated, constructed, and tested a simple and low-cost IoT-based automatic entry system. The system is portable, and no staff are required to measure all of the fundamental health measures that could be used to protect us against COVID infection. We have already witnessed that police officers and security guards are the most vulnerable to contracting the virus as in all institutes they are in charge of measuring these basic health protocols. Until the foreseeable future, our idea could be a sustainable solution to this crisis.

### **10.2 Future work**

In the future, this project has a lot of scope to work on as we have already showed how much modification can be done to the system. We can improve the project in many aspects such as the user interface, usability, functionality, accuracy increase etc. So, if we think in that way, we can add improve in few of this thing in future:

- i. Integration of Deep Learning-Based cough Recognition Model to evaluate the cough sound to find trace of covid-19 dry cough rhythmic pattern.
- ii. LED display to show all the prompts and data for user friendliness.
- iii. Motion sensors can be added with the temperature and SpO2 sensor for easier usability as it can get confused sometime when the sensor will start reading data.
- iv. Biometric verification can be implemented for better security.
- v. Masked face detection using Deep Learning can be developed and integrated with the already used face-mask detection model to identify person's face though they are wearing mask.

These improvements can make this device much more suitable for commercialized use.

## **Chapter 11: Identification of Complex Engineering Problems and Activities.**

### **11.1 Identify the attribute of complex engineering problem (EP)**

The great difficulties of the twenty-first century need the human race to overcome issues and face uncertainties that we have never encountered before. According to the World Economic Forum (2016), Complex Problem Solving will be the most crucial talent for the fourth industrial revolution by 2020. As a result, having competent problem-solving abilities is becoming increasingly important in this century. Component segments or sub-problems are included in complex engineering problems, which are high-level problems. Solutions to complicated engineering challenges are hardly ever clear and need abstract thinking or inventiveness in analysis in order to develop appropriate models. There are also different attributes to consider while identifying and subsequently solving these complicated engineering problems. In our project we have identified and addressed these attributes. Those attributes are as follows –

- i. Depth of knowledge
- ii. Depth of analysis
- iii. Extent of stakeholder involvement and needs

### **11.2 Provide reasoning how the project address selected attribute (EP)**

As previously stated, we have identified certain attributes. The following is a more in-depth discussion:

#### **Depth of Knowledge**

The system we have designed will help people tackle this virus as the main objective of our project is to check for symptoms, precautions and then give the person entry based on the readings the system gets. A certain level of knowledge is required to construct this system. As our project undeviatingly deals with health aspects of the human body, level of expertise in certain health procedures are the epitome of the things that need to be acknowledged.

To begin, we have used raspberry pi 4 to be our on-board computer for our system. Previously, we chose Arduino, however owing to several constraints, we altered our choices. The Raspberry Pi is a single board computer the size of a credit card that weighs only 50g.

Moving on, we implemented certain sensors to check oxygen saturation level and body temperature. Firstly, we have added a pulse oximeter device that will monitor the user's oxygen saturation level, which is set by WHO regulation to be greater than 95 percent to ensure the individual does not have a possible COVID infection. We chose the MAX30100 sensor, which is an integrated pulse oximetry and heart-rate monitor sensor solution, for this. It detects pulse oximetry and heart-rate signals by combining two LEDs, a photodetector, improved optics, and low-noise analog signal processing. It has an accuracy of 97.10% [11], which is comparable to hospital evaluations. As a result, our approach to monitor oxygen saturation level is validated.

Then, to measure body temperature, we have used a contactless technique. The MLX90614 is being used as the sensor. It is a noncontact Infrared thermometer. Besides, for one of the

core features of our designed project which is face mask detection, we have used a deep learning algorithm. The deep learning model has a robust learning capacity that merges the feature extraction and classification processes into a single procedure to complete the image classification test, effectively improving image classification accuracy. Adding to this, we have implemented our project based on RFID log which will store in Firebase.

As can be seen, we employed a variety of engineering methodologies and tools to determine the best solution to the problem that has been disrupting our everyday lives for nearly two years. When we look at the core strategy, we have designed an embedded system that allows all components to function at the same time. As a result, the requirement for intermediary hardware and software to set up the system is obvious. To achieve our project aim, we have learned and applied techniques such as machine learning, Linux commands, python scripting, and sensor technologies. Furthermore, because this is an IoT project[12], we have studied the fundamentals of data structures and networking.

### **Depth of Analysis**

Given our system primarily deals with human body health measurements, there must be a significant deal of analysis in terms of utilizing the components, designing, using the best method for developing the system, and data analyzing. We have tested our sensors, used adequate safe equipment, and inspected the conclusion of our system, which is presented at the end of our project's presentation, in order to emit any possible health concerns regarding its users' health. We have also assured that our completed project has a significantly positive influence on people's health safety. Adding to this, we have collected data from our database to ensure the accuracy of the system. Data analyzing has been one of the most important tasks in this tenure of our project timeline. It gave us deeper insights into the people who used our system, allowing us to adapt customer service to their requirements and expedite our operations, boosting our bottom line. The collecting of data in health care settings has become incredibly valuable in COVID times. Not only does the data assist enhance day-to-day operations and provide a more secure environment, but it can also now be utilized in predictive modeling. Our datasets may be used to track trends and create forecasts. We can take preventive actions and monitor the results. It can help us to research further towards more effectiveness of our system.

### **Familiarity of the issue**

The coronavirus has brought the entire world to a halt. This Pandemic has affected millions of people globally. And we're nearly two years into this calamitous pandemic. We rely on concealing our faces and maintaining our temperature and oxygen saturation to survive the virus. Vaccines, on the other hand, are now available, offering some measure of protection against the spread of this lethal disease. They have not been shown to be completely effective against all coronavirus types. As a result, our work investigated all of the pandemic's crucial components. The most essential thing for everyone to do during this pandemic is to stay safe and avoid random human contact. Even still, many people are forced to go outside and work in order to make a living. Keeping the current issue in mind, we created this project to safeguard their health and safety at work.

### **Extent of Stakeholder involvement and needs**

Individuals and organizations actively engaged in the project, or whose interests may be impacted positively or negatively as a result of project execution or successful project completion, are classified as stakeholders. We expect to launch our project on a commercial scale. As a result, stakeholders will eventually help to make our project better than what is executed. Initially, we intend to implement our product on the campus of our university. So, we have made this project keeping our campus in mind. Every day, thousands of individuals attend our university. As a result, adequate screening at the entry gate is vital. As a result, the university students and staff are now stakeholders in our project. So, we took a survey to understand and implement the stakeholder's needs in our project. We got interesting data's out of the survey. Due to the widespread distribution of COVID-19, BRAC University has begun offering online classes from early 2020. However, the university administration has recently attempted to go entirely on campus. As a result, we have a perfect opportunity to employ our product in the entry gates. In our study, we have discovered that most of the students agree with one of our points: having the COVID-19 symptoms examined by security guards is a time-consuming process and the 73.7% of the students do feel the necessity of an automated system that checks masks, oxygen saturation, and body temperature all at once.

However, the majority is hesitant to consent to disclose health data to the system. One of the primary reasons for this might be because people desire to keep the identities of those who are possibly COVID-19 positive private in order to avoid turbulence among others who are going through the process. To address this issue, the whole project will be implemented while keeping a safe social distance while approaching the premises. If a potentially dangerous case is identified, he or she will be quickly sent to the appropriate facilities.

We hope to prevent and eliminate any risk that may jeopardize our department and university during the design and implementation of our project. However, if any flaws or potentially dangerous issues are identified, the department can take the appropriate steps to fix them before they reach real-time users.

### **11.3 Identify the attribute of complex engineering activities (EA)**

For giving a sustainable and effective solution to any complex engineering problem certain sorts of engineering activities are involved. In our project we also came across certain activities these are –

- Range of resources
- Level of interaction
- Consequences for society and the environment
- Familiarity

## **11.4 Reasoning of the selected attributes of Complex Engineering Activities**

A variety of engineering tasks are required to provide a long-term and successful solution to any complicated engineering challenge. In our project, we came across the following activities:

### **Range of resources**

A variety of resources are required to take this sort of endeavor off the ground. As Electrical Engineers, we are expected to handle these sorts of work - related problems. So, from initiating till the completion we used a wide range of resources. As we are not experienced with real time system designing, we relied on resources from various websites which aided us to complete the project satisfactorily. In terms of embedding the system we used resources from YouTube primarily. We have also developed our algorithms for mask detection from GitHub. Our ATC panel has also provided us with various research papers that helped us throughout the project cycle. However, we used all these resources till a certain extent mitigating any possibilities of plagiarizing. We have taken assistance from these resources and then developed our unique systematic solution to our identified complex engineering problem.

### **Level of interaction**

Our system requires a very high level of interaction from its user. Only if our system gets data that fits our threshold values will the user be allowed to access the premises. Furthermore, because all data is maintained in a cloud server, enterprises that own our product will receive data on persons who accessed their premises. As a result, this makes really good use of user interaction.

### **Consequences for society and the environment**

We are in the middle of a worldwide health catastrophe unprecedented in the last century. This epidemic has had a massively negative influence on many aspects of our existence. The part of societal acceptability, justice, and effect of any particular machinery or new inventive ideas/technologies that will lead to a higher quality of life is referred to as social consequences. In terms of social acceptance and awareness we have some ideas that we aim to implement when we move towards the commercial stage of this product. In terms of the environment, we designed this project with campuses, business offices, and other places where large crowds meet in mind. And, as a result of our project's execution, the general environment of these facilities will be considerably safer, and employees will feel more confident about working there

### **Familiarity**

The components in our system (Raspberry Pi/MAX30100/MLX90614) are widely available and well-known[13]. Except for the algorithm, which may be improved with the assistance of a specialist, the entire system is extremely impactful and relatively straightforward to adopt for everyone.

### Attributes of Complex Engineering Problems (EP)

	Attributes	Put tick (✓) as appropriate
P1	Depth of knowledge required	✓
P2	Range of conflicting requirements	
P3	Depth of analysis required	✓
P4	Familiarity of issues	✓
P5	Extent of applicable codes	
P6	Extent of stakeholder involvement and needs	✓
P7	Interdependence	

### Attributes of Complex Engineering Activities (EA)

	Attributes	Put tick (✓) as appropriate
A1	Range of resource	✓
A2	Level of interaction	✓
A3	Innovation	
A4	Consequences for society and the environment	✓
A5	Familiarity	✓

## References

- [1] “Not wearing masks and the consequences,” Dhaka Tribune, Oct. 27, 2020. <https://archive.dhakatribune.com/health/coronavirus/2020/10/27/not-wearing-masks-and-the-consequences> (accessed Jul. 27, 2022).
- [2] “Coronavirus: Security guards are most at risk of dying with COVID-19, figures show,” Sky News. <https://news.sky.com/story/coronavirus-security-guards-are-most-at-risk-of-dying-with-covid-19-figures-show-12015241> (accessed Jul. 27, 2022).
- [3] H. Adusumalli, D. Kalyani, R. K. Sri, M. Pratapreja, and P. V. R. D. P. Rao, “Face Mask Detection Using OpenCV,” Proc. Int. Conf. Intell. Commun. Technol. Virtual Mob. Networks, ICICV, pp. 1304–1309, 2021.
- [4] P. Szakacs-Simon, S.-A. Moraru, and L. Perniu, “Pulse oximeter based monitoring system for people at risk,” Nov. 2012, pp. 415–419. doi: 10.1109/CINTI.2012.6496802.
- [5] A. Das, M. W. Ansari, and R. Basak, “Covid-19 Face Mask Detection Using TensorFlow, Keras and OpenCV,” Dec. 2020, pp. 1–5. doi: 10.1109/INDICON49873.2020.9342585.
- [6] B. Ning and Y. Wu, “Research on Non-Contact Infrared Temperature Measurement,” 2010 International Conference on Computational Intelligence and Software Engineering, 2010, doi: 10.1109/CISE.2010.5677034.
- [7] H. Australia, “How to monitor COVID-19 symptoms,” Mar. 01, 2022. <https://www.healthdirect.gov.au/covid-19/how-to-monitor-symptoms> (accessed Apr. 06, 2022).
- [8] G. CHEN et al., “Validity of the Use of Wrist and Forehead Temperatures in Screening the General Population for COVID-19: A Prospective Real-World Study,” Iran J Public Health, vol. 49, no. Suppl 1, pp. 57–66, Oct. 2020, doi: 10.18502/ijph.v49iS1.3670.
- [9] “COVID-19 vaccine efficacy and effectiveness-the elephant (not) in the room - PubMed.” <https://pubmed.ncbi.nlm.nih.gov/33899038/> (accessed Jul. 27, 2022).
- [11] N. Sari, M. Gani, R. Yusuf, and R. Firmando, “Telemedicine for silent hypoxia: Improving the reliability and accuracy of Max30100-based system,” Indonesian Journal of Electrical Engineering and Computer Science, vol. 22, p. 1419, Jun. 2021, doi: 10.11591/ijeecs.v22.i3.pp1419-1426.
- [12] S. Vanitha, P. Balasubramanie, K. Arvind, N. V.R, and S. Elumalai, “INTERNET OF THINGS: A REVIEW ON THEIR REQUISITE IN THE DIGITAL ERA,” vol. 29, pp. 591–602, May 2020.
- [13] K. B. Saçan and G. Ertas, “Performance assessment of MAX30100 SpO2/hearttrate sensor,” in 2017 Medical Technologies National Congress (TIPTEKNO), Oct. 2017, pp. 1–4. doi: 10.1109/TIPTEKNO.2017.8238126.

## Appendix

### Logbook

	<b>Final Year Design Project (P) Spring 2021</b>		
<i>Student Details</i>	<i>Name &amp; ID</i>	<i>Email address</i>	<i>Phone</i>
<b>Member 1</b>	Tahsin Muhtady Mahi (18121005)	tahsin.muhtady.mahi@g.bracu.ac.bd	01776535493
<b>Member 2</b>	Rubaiyat Alam Ruhin (18121067)	rubaiyat.alam.ruhin@g.bracu.ac.bd	01758428209
<b>Member 3</b>	Aminul Islam (18121007)	aminul.islam2@g.bracu.ac.bd	01794626432
<i>ATC Details:</i>			
<b>ATC 5</b>			
<b>Chair</b>	Dr. Abu S. M. Mohsin	asm.mohsin@bracu.ac.bd	
<b>Member 1</b>	Taiyeb Hasan Sakib	taiyeb.sakib@bracu.ac.bd	



## Logbook for EEE400P (Spring 2021)

Date/Time/Place	Attendee	Summary of Meeting Minutes	Responsible	Comment by ATC
03.03.2021	1. Aminul 2. Ruhin 3. Mahi	1. Exploring field of interests 2. Browsing through Projects from the field of interests 3. Topic Selection	1. Aminul 2. Ruhin 3. Mahi	
11.03.2021	1. Aminul 2. Ruhin 3. Mahi	ATC Meeting regarding topic selection	1. Aminul 2. Ruhin 3. Mahi	ATC suggested to add more features to the system
13.03.2021	1. Aminul 2. Ruhin 3. Mahi	Further discussion on topic selection	1. Aminul 2. Ruhin 3. Mahi	
20.03.2021	1. Aminul 2. Ruhin 3. Mahi	1. Topic Selection 2. Improving the concept 3. Related article and paper selection	1. Aminul 2. Ruhin 3. Mahi	
23.03.2021	1. Aminul 2. Ruhin 3. Mahi	Draft concept paper preparation	1. Aminul (Problem statement) 2. Ruhin (Specification and requirement) 3. Mahi (objective)	
25.03.2021	1. Aminul 2. Ruhin 3. Mahi	ATC Meeting regarding the draft concept note	1. Aminul 2. Ruhin 3. Mahi	ATC suggested to make the objective section a bit more explanatory
27.03.2021	1. Aminul 2. Ruhin 3. Mahi	Discussion on reflecting the suggestions given by our ATC members in our concept note	1. Aminul 2. Ruhin 3. Mahi	
29.03.2021	1. Aminul 2. Ruhin 3. Mahi	Discussion on new topic selection	1. Aminul 2. Ruhin 3. Mahi	
01.04.2021	1. Aminul 2. Ruhin 3. Mahi	ATC Meeting regarding changing the topic	1. Aminul 2. Ruhin 3. Mahi	
09.04.2021	1. Aminul 2. Ruhin 3. Mahi	1. New Topic selection 2. Draft concept paper preparation	1. Aminul (Problem statement, Applicable standards and codes)	

			2. Ruhin (Specification and requirement, Requirements and Constraints Applicable standard and codes) 3. Mahi (objective, Applicable standard and codes)	
19.04.2021	1. Aminul 2. Ruhin 3. Mahi	ATC Meeting regarding the new selected topic and draft concept paper	1. Aminul 2. Ruhin 3. Mahi	ATC members suggested to add a little detail to the system
22.04.2021	1. Aminul 2. Ruhin 3. Mahi	Improving and finalizing the concept note	1. Aminul 2. Ruhin 3. Mahi	
28.04.2021	1. Aminul 2. Ruhin 3. Mahi	Discussion on report writing and presentation techniques right after scheduled FYDP L-8	1. Aminul 2. Ruhin 3. Mahi	
2.05.2021	1. Aminul 2. Ruhin 3. Mahi	Additional features to the current project were discussed.	1. Aminul 2. Ruhin 3. Mahi	
06.05.2021	1. Aminul 2. Ruhin 3. Mahi	ATC Meeting regarding the proposal letter and presentation	1. Aminul 2. Ruhin 3. Mahi	
10.05.2021	1. Aminul 2. Ruhin 3. Mahi	Started working on the project proposal	1. Aminul (Impacts, Ethical Consideration) 2. Ruhin (Methodology, Project Plan, Budget, Expected Solution) 3. Mahi (Sustainability, Risk Management)	
12.05.2021	1. Aminul 2. Ruhin 3. Mahi	General team meeting on catching up on everyone's work	1. Aminul 2. Ruhin 3. Mahi	All previous task completed
16.05.2021	1. Aminul 2. Ruhin 3. Mahi	General team meeting on catching up on everyone's work	1. Aminul 2. Ruhin 3. Mahi	Completion of proposal letter's first draft.

## Logbook for EEE400D (Summer 2021)

Date/Time/Place	Attendee	Summary of Meeting Minutes	Responsible	Comment by ATC
24-06-2021	1. Rubaiyat Alam Ruhin 2. Aminul Islam 3. Tahsin Muhtady Mahi	1. Propose multiple designs to achieve our objective 2. Selection of the optimal design	1. Rubaiyat Alam Ruhin(Face mask detection) 2. Aminul Islam(Pulse Oximeter) 3. Tahsin Muhtady Mahi(Thermometer)	
01-07-2021	1. Rubaiyat Alam Ruhin 2. Aminul Islam 3. Tahsin Muhtady Mahi	1. Proper tool and device selection for the design 2. Analysis of the solution	1. Rubaiyat Alam Ruhin(Face mask detection) 2. Aminul Islam(Pulse Oximeter) 3. Tahsin Muhtady Mahi(Thermometer)	
06-07-2021	1. Rubaiyat Alam Ruhin 2. Aminul Islam 3. Tahsin Muhtady Mahi	1 <sup>st</sup> Progress Presentation Preparation	1. Rubaiyat Alam Ruhin 2. Aminul Islam 3. Tahsin Muhtady Mahi	
08-07-2021	1. Rubaiyat Alam Ruhin 2. Aminul Islam 3. Tahsin Muhtady Mahi	1. Review on the review of the presentation 2. Decide and implement necessary changes	1. Rubaiyat Alam Ruhin(Face mask detection) 2. Aminul Islam(Pulse Oximeter) 3. Tahsin Muhtady Mahi(Thermometer)	
15-07-2021	1. Rubaiyat Alam Ruhin 2. Aminul Islam 3. Tahsin Muhtady Mahi	1. Face mask detection development and trial	1. Rubaiyat Alam Ruhin	
16-07-2021	1. Rubaiyat Alam Ruhin 2. Aminul Islam 3. Tahsin Muhtady Mahi	ATC meeting	1. Rubaiyat Alam Ruhin 2. Aminul Islam 3. Tahsin Muhtady Mahi	
22-07-2021	1. Rubaiyat Alam Ruhin 2. Aminul Islam 3. Tahsin Muhtady Mahi	1. Face mask detection development (cotd.)	1. Rubaiyat Alam Ruhin	
29-07-2021	1. Rubaiyat Alam Ruhin 2. Tahsin Muhtady Mahi	1. Searching the market for our required hardware material	1. Rubaiyat Alam Ruhin(Pulse Oximeter) 2. Tahsin Muhtady Mahi(Thermometer)	
05-08-2021	1. Rubaiyat Alam Ruhin 2. Tahsin Muhtady Mahi	1. Searching the market for our required hardware material (cotd.)	3. Rubaiyat Alam Ruhin(Pulse Oximeter) 1. Tahsin Muhtady Mahi(Thermometer)	

10-08-2021	1. Rubaiyat Alam Ruhin 2. Tahsin Muhtady Mahi	2 <sup>nd</sup> Progress presentation preparation	1. Rubaiyat Alam Ruhin 2. Tahsin Muhtady Mahi	
11-08-2021	1. Rubaiyat Alam Ruhin 2. Tahsin Muhtady Mahi	2 <sup>nd</sup> Progress presentation preparation (cotd.)	1. Rubaiyat Alam Ruhin 2. Tahsin Muhtady Mahi	
12-08-2021	1. Rubaiyat Alam Ruhin 2. Tahsin Muhtady Mahi	1. Review on the review of the presentation 2. Decide and implement necessary changes	4. 1. Rubaiyat Alam Ruhin(Face mask and Pulse Oximeter) Tahsin Muhtady Mahi(Thermometer)	
19-08-2021	1. Rubaiyat Alam Ruhin 2. Tahsin Muhtady Mahi	1. Thinking of more alternate designs	5. 1. Rubaiyat Alam Ruhin(Pulse Oximeter) Tahsin Muhtady Mahi(Thermometer)	
26-08-2021	1. Rubaiyat Alam Ruhin 2. Aminul Islam 3. Tahsin Muhtady Mahi	1. Ordering all the hardware materials after further inspection of the market	2. Rubaiyat Alam Ruhin(Face mask detection) 2. Aminul Islam(Pulse Oximeter) 1. 3. Tahsin Muhtady Mahi(Thermometer)	
01-09-2021	1. Rubaiyat Alam Ruhin 2. Aminul Islam 3. Tahsin Muhtady Mahi	1. ATC meeting on draft design report 2. Draft design report Preparation	1. Rubaiyat Alam Ruhin() 2. Aminul Islam() 3. Tahsin Muhtady Mahi()	
09-09-2021	1. Rubaiyat Alam Ruhin 2. Aminul Islam 3. Tahsin Muhtady Mahi	1. Further touch up on the final design report		
14-09-2021	1. Rubaiyat Alam Ruhin 2. Aminul Islam 3. Tahsin Muhtady Mahi	1. Final Progress presentation preparation 2. Full Design report preparation		
15-09-2021	3. Rubaiyat Alam Ruhin 4. Aminul Islam Tahsin Muhtady Mahi	Final Progress presentation preparation (cotd.)		

## Logbook for EEE400C (Fall 2021)

Date/Time/Place	Attendee	Summary of Meeting Minutes	Responsible	Comment by ATC
04-10-21	1 Rubaiyat Alam Ruhin 2 Aminul Islam 3 Tahsin Muhtady Mahi	Arbitrary meeting regarding the prototype	1 Rubaiyat Alam Ruhin 2 Aminul Islam 3 Tahsin Muhtady Mahi	
12-10-21	1 Rubaiyat Alam Ruhin 2 Aminul Islam 3 Tahsin Muhtady Mahi	Arbitrary meeting regarding the prototype	1 Rubaiyat Alam Ruhin 2 Aminul Islam 3 Tahsin Muhtady Mahi	
20-10-21	1 Rubaiyat Alam Ruhin 2 Aminul Islam 3 Tahsin Muhtady Mahi	Arbitrary meeting regarding the prototype	1 Rubaiyat Alam Ruhin 2 Aminul Islam 3 Tahsin Muhtady Mahi	
28-10-21	1 Rubaiyat Alam Ruhin 2 Aminul Islam 3 Tahsin Muhtady Mahi	Arbitrary meeting regarding the prototype	1 Rubaiyat Alam Ruhin 2 Aminul Islam 3 Tahsin Muhtady Mahi	
02-11-21	1. Rubaiyat Alam Ruhin 2. Aminul Islam 3. Tahsin Muhtady Mahi	<b>ATC Meeting regarding project progress</b>	1 Rubaiyat Alam Ruhin 2 Aminul Islam 3 Tahsin Muhtady Mahi	ATC panel suggested to start the hardware development quickly
07-11-21	1 Rubaiyat Alam Ruhin 2 Aminul Islam 3 Tahsin Muhtady Mahi	Weekly meeting regarding hardware 1. Testing the face mask code and Raspberry pi camera	1 Rubaiyat Alam Ruhin 2 Aminul Islam 3 Tahsin Muhtady Mahi	
09-11-21	1 Rubaiyat Alam Ruhin 2 Aminul Islam 3 Tahsin Muhtady Mahi	ATC Meeting regarding project progress	1 Rubaiyat Alam Ruhin 2 Aminul Islam 3 Tahsin Muhtady Mahi	ATC wanted a brief detailed report on the project progress.
14-11-21	1 Rubaiyat Alam Ruhin 2 Aminul Islam 3 Tahsin Muhtady Mahi	Weekly meeting regarding hardware 1. Re testing the face mask detection	1 Rubaiyat Alam Ruhin 2 Aminul Islam 3 Tahsin Muhtady Mahi	

		2. Testing the other sensors individually		
16-11-21	1 Rubaiyat Alam Ruhin 2 Aminul Islam 3 Tahsin Muhtady Mahi	<b>ATC Meeting regarding project progress</b>	1 Rubaiyat Alam Ruhin 2 Aminul Islam 3 Tahsin Muhtady Mahi	ATC suggested us to demonstrate the project in the next meeting, They also instructed us to start working on the report
21-11-21	1 Rubaiyat Alam Ruhin 2 Aminul Islam 3 Tahsin Muhtady Mahi	Weekly meeting regarding hardware 1. Assembling the sensors together and make the prototype up and running	1 Rubaiyat Alam Ruhin 2 Aminul Islam 3 Tahsin Muhtady Mahi	
23-11-21	1 Rubaiyat Alam Ruhin 2 Aminul Islam 3 Tahsin Muhtady Mahi	<b>ATC Meeting regarding project progress</b>	1 Rubaiyat Alam Ruhin 2 Aminul Islam 3 Tahsin Muhtady Mahi	Raspberry Pi installation and Face mask implementation was demonstrated. ATC panel wanted a fully functional prototype.
25-11-21	1 Rubaiyat Alam Ruhin 2 Aminul Islam 3 Tahsin Muhtady Mahi	<b>Prototype Presentation</b>	1 Rubaiyat Alam Ruhin 2 Aminul Islam 3 Tahsin Muhtady Mahi	
30-11-21	1 Rubaiyat Alam Ruhin 2 Aminul Islam 3 Tahsin Muhtady Mahi	<b>ATC Meeting regarding project progress</b>	1 Rubaiyat Alam Ruhin 2 Aminul Islam 3 Tahsin Muhtady Mahi	ATC panel Reflected their feedback after the prototype presentation

07-12-21	1 Rubaiyat Alam Ruhin 2 Aminul Islam 3 Tahsin Muhtady Mahi	<b>ATC Meeting regarding project progress</b>	1 Rubaiyat Alam Ruhin 2 Aminul Islam 3 Tahsin Muhtady Mahi	ATC panel wanted to see a fully functional project by next week. They also wanted to see the work on the report writing.
10-12-21	1 Rubaiyat Alam Ruhin 2 Aminul Islam 3 Tahsin Muhtady Mahi	Weekly meeting regarding hardware and start working of Report 1. Allocating the tasks between the members.	1 Rubaiyat Alam Ruhin 2 Aminul Islam 3 Tahsin Muhtady Mahi	
12-12-21	1 Rubaiyat Alam Ruhin 2 Aminul Islam 3 Tahsin Muhtady Mahi	Weekly meeting regarding Report 1. Reviewing the progress on the report writing	1 Rubaiyat Alam Ruhin 2 Aminul Islam 3 Tahsin Muhtady Mahi	
14-12-21	1 Rubaiyat Alam Ruhin 2 Aminul Islam 3 Tahsin Muhtady Mahi	<b>ATC Meeting regarding project progress</b>	1 Rubaiyat Alam Ruhin 2 Aminul Islam 3 Tahsin Muhtady Mahi	ATC Panel gave suggested the necessary changes in the report structure. Also, instructed to make the PCB
17-12-21	1 Rubaiyat Alam Ruhin 2 Aminul Islam 3 Tahsin Muhtady Mahi	Weekly meeting regarding hardware and start working of Report 1. Designing the layout for the PCB 2. Reviewing the progress on the report writing	1 Rubaiyat Alam Ruhin 2 Aminul Islam 3 Tahsin Muhtady Mahi	
19-12-21	1 Rubaiyat Alam Ruhin 2 Aminul Islam 3 Tahsin Muhtady Mahi	Weekly meeting regarding Report 1. Reviewing the progress on the report writing	1 Rubaiyat Alam Ruhin 2 Aminul Islam 3 Tahsin Muhtady Mahi	

21-12-21	1 Rubaiyat Alam Ruhin 2 Aminul Islam 3 Tahsin Muhtady Mahi	ATC Meeting regarding project progress 1. Demonstration of the running project	1 Rubaiyat Alam Ruhin 2 Aminul Islam 3 Tahsin Muhtady Mahi	ATC Suggested we demonstrate the full project as one of our sensors was not functioning properly and we had to replace it
24-12-21	1 Rubaiyat Alam Ruhin 2 Aminul Islam 3 Tahsin Muhtady Mahi	Weekly meeting regarding hardware and start working of Report 1. Replacing the Oximeter sensor and implement the display 2. Implementing signaling system to notify the results	1 Rubaiyat Alam Ruhin 2 Aminul Islam 3 Tahsin Muhtady Mahi	
26-11-21	1 Rubaiyat Alam Ruhin 2 Aminul Islam 3 Tahsin Muhtady Mahi	Weekly meeting regarding Report 1. Reviewing the progress on the report writing	1 Rubaiyat Alam Ruhin 2 Aminul Islam 3 Tahsin Muhtady Mahi	
28-12-21	1 Rubaiyat Alam Ruhin 2 Aminul Islam 3 Tahsin Muhtady Mahi	<b>ATC Meeting regarding project progress</b> 1. Full demonstration of the running project 2. partial report presentation 2. E-mailing the report to the ATC	1 Rubaiyat Alam Ruhin 2 Aminul Islam 3 Tahsin Muhtady Mahi	ATC panel gave a brief changes that were necessary for the final report.
30-12-21	1 Rubaiyat Alam Ruhin 2 Aminul Islam 3 Tahsin Muhtady Mahi	Weekly meeting regarding Hardware 1. Designing the PCB layout	1 Rubaiyat Alam Ruhin 2 Aminul Islam 3 Tahsin Muhtady Mahi	
02-01-22	1 Rubaiyat Alam Ruhin 2 Aminul Islam 3 Tahsin Muhtady Mahi	Weekly meeting regarding Report 1. Finishing touch to the report.	1 Rubaiyat Alam Ruhin 2 Aminul Islam 3 Tahsin Muhtady Mahi	



## Codes:

### Main Sequence

- Main

```
import os
import time
from datetime import date
from RFID_RC522 import rfid
from Face_mask_detection import detect_mask_video
from MLX90614 import temp
from MAX30100 import spo2
import indicator
import upload_firestore_rpi

def workflow():
    print('Enter RFID Card: ')
    ID = rfid.read_rfid()
    if ID[0] is not None:
        masked = detect_mask_video.main()
        if masked == 1:
            while True:
                time.sleep(3)
                print('Place your finger for temperature: ')
                t = temp.read_temp()
                if t >= 95 and t < 108:
                    break
                else:
                    print("Try again")
                    indicator.led_try()

            while True:
                print('Place your finger for oxygen saturation: ')
                ox_sat = spo2.read_spo2()
                if ox_sat >= 90 and ox_sat <= 100:
                    break
                else:
                    print("Try again")
                    indicator.led_try()

            # show risk factors
            if t <= 99 and ox_sat > 95:
                risk = 'No Risk'
            elif t > 99 and t < 100.4 and ox_sat > 95 or t < 99 and ox_sat < 95 or t > 100.4 and ox_sat > 95:
                risk = 'Moderate Risk'
            else:
                risk = 'High Risk'

            print("Entry Risk: ",risk)
```

```

indicator.led(risk)

# upload the data to firebase
# getting date
today = date.today()
current_date = today.strftime("%b-%d-%Y")

# getting time
now = time.localtime()
current_time = time.strftime("%H:%M:%S", now)

user_data = {'ID': ID[0], 'Name': ID[1], 'Mask': 'Yes',
             'Oxygen Sat': f'{ox_sat}%', 'Temperature':
             f'{t}F', 'Risk': risk, 'Date': current_date,
             'Time': current_time}

# push data to firebase
upload_firebase_rpi.main(user_data)

time.sleep(1)
workflow()

else:
    workflow()

else:
    workflow()

def main():
    workflow()

if __name__ == '__main__':
    main()

```

## RFID module

- **Write**

```
import RPi.GPIO as GPIO
from mfrc522 import SimpleMFRC522

reader = SimpleMFRC522()

try:
    text = input('New data:')
    print("Now place your tag to write")
    reader.write(text)
    print("Written")
finally:
    GPIO.cleanup()
```

- **Read**

```
import RPi.GPIO as GPIO
from mfrc522 import SimpleMFRC522

def read_rfid():
    reader = SimpleMFRC522()
    try:
        id, text = reader.read()
        print(id)
        print(text)
    finally:
        GPIO.cleanup()
    return id, text

def main():
    read_rfid()

if __name__ == '__main__':
    main()
```

## Face-mask detection

- **Train**

```
# import the necessary packages
from tensorflow.keras.preprocessing.image import ImageDataGenerator
from tensorflow.keras.applications import MobileNetV2
from tensorflow.keras.layers import AveragePooling2D
from tensorflow.keras.layers import Dropout
from tensorflow.keras.layers import Flatten
from tensorflow.keras.layers import Dense
from tensorflow.keras.layers import Input
from tensorflow.keras.models import Model
from tensorflow.keras.optimizers import Adam
from tensorflow.keras.applications.mobilenet_v2 import preprocess_input
from tensorflow.keras.preprocessing.image import img_to_array
from tensorflow.keras.preprocessing.image import load_img
from tensorflow.keras.utils import to_categorical
from sklearn.preprocessing import LabelBinarizer
from sklearn.model_selection import train_test_split
from sklearn.metrics import classification_report
from imutils import paths
import matplotlib.pyplot as plt
import numpy as np
import os

# initialize the initial learning rate, number of epochs to train for,
# and batch size
INIT_LR = 1e-4
EPOCHS = 20
BS = 32

DIRECTORY = r"C:\Mask Detection\CODE\Face-Mask-Detection-master\dataset"
CATEGORIES = ["with_mask", "without_mask"]

# grab the list of images in our dataset directory, then initialize
# the list of data (i.e., images) and class images
print("[INFO] loading images...")

data = []
labels = []

for category in CATEGORIES:
    path = os.path.join(DIRECTORY, category)
    for img in os.listdir(path):
        img_path = os.path.join(path, img)
        image = load_img(img_path, target_size=(224, 224))
        image = img_to_array(image)
        image = preprocess_input(image)
```

```

        data.append(image)
        labels.append(category)

# perform one-hot encoding on the labels
lb = LabelBinarizer()
labels = lb.fit_transform(labels)
labels = to_categorical(labels)

data = np.array(data, dtype="float32")
labels = np.array(labels)

(trainX, testX, trainY, testY) = train_test_split(data, labels,
        test_size=0.20, stratify=labels, random_state=42)

# construct the training image generator for data augmentation
aug = ImageDataGenerator(
    rotation_range=20,
    zoom_range=0.15,
    width_shift_range=0.2,
    height_shift_range=0.2,
    shear_range=0.15,
    horizontal_flip=True,
    fill_mode="nearest")

# load the MobileNetV2 network, ensuring the head FC layer sets are
# left off
baseModel = MobileNetV2(weights="imagenet", include_top=False,
        input_tensor=Input(shape=(224, 224, 3)))

# construct the head of the model that will be placed on top of the
# the base model
headModel = baseModel.output
headModel = AveragePooling2D(pool_size=(7, 7))(headModel)
headModel = Flatten(name="flatten")(headModel)
headModel = Dense(128, activation="relu")(headModel)
headModel = Dropout(0.5)(headModel)
headModel = Dense(2, activation="softmax")(headModel)

# place the head FC model on top of the base model (this will become
# the actual model we will train)
model = Model(inputs=baseModel.input, outputs=headModel)

# loop over all layers in the base model and freeze them so they will
# *not* be updated during the first training process
for layer in baseModel.layers:
    layer.trainable = False

# compile our model

```

```

print("[INFO] compiling model...")
opt = Adam(lr=INIT_LR, decay=INIT_LR / EPOCHS)
model.compile(loss="binary_crossentropy", optimizer=opt,
              metrics=["accuracy"])

# train the head of the network
print("[INFO] training head...")
H = model.fit(
    aug.flow(trainX, trainY, batch_size=BS),
    steps_per_epoch=len(trainX) // BS,
    validation_data=(testX, testY),
    validation_steps=len(testX) // BS,
    epochs=EPOCHS)

# make predictions on the testing set
print("[INFO] evaluating network...")
predIdxs = model.predict(testX, batch_size=BS)

# for each image in the testing set we need to find the index of the
# label with corresponding largest predicted probability
predIdxs = np.argmax(predIdxs, axis=1)

# show a nicely formatted classification report
print(classification_report(testY.argmax(axis=1), predIdxs,
                          target_names=lb.classes_))

# serialize the model to disk
print("[INFO] saving mask detector model...")
model.save("mask_detector.model", save_format="h5")

# plot the training loss and accuracy
N = EPOCHS
plt.style.use("ggplot")
plt.figure()
plt.plot(np.arange(0, N), H.history["loss"], label="train_loss")
plt.plot(np.arange(0, N), H.history["val_loss"], label="val_loss")
plt.plot(np.arange(0, N), H.history["accuracy"], label="train_acc")
plt.plot(np.arange(0, N), H.history["val_accuracy"], label="val_acc")
plt.title("Training Loss and Accuracy")
plt.xlabel("Epoch #")
plt.ylabel("Loss/Accuracy")
plt.legend(loc="lower left")
plt.savefig("plot.png")

```

- **Detect**

```

from tensorflow.keras.applications.mobilenet_v2 import preprocess_input
from tensorflow.keras.preprocessing.image import img_to_array
from tensorflow.keras.models import load_model

```

```

from imutils.video import VideoStream
import numpy as np
import imutils
import time
import cv2

def detect_and_predict_mask(frame, faceNet, maskNet):
    # grab the dimensions of the frame and then construct a blob
    # from it
    (h, w) = frame.shape[:2]
    blob = cv2.dnn.blobFromImage(frame, 1.0, (224, 224),
        (104.0, 177.0, 123.0))

    # pass the blob through the network and obtain the face detections
    faceNet.setInput(blob)
    detections = faceNet.forward()
    print(detections.shape)

    # initialize our list of faces, their corresponding locations,
    # and the list of predictions from our face mask network
    faces = []
    locs = []
    preds = []

    # loop over the detections
    for i in range(0, detections.shape[2]):
        # extract the confidence (i.e., probability) associated with
        # the detection
        confidence = detections[0, 0, i, 2]

        # filter out weak detections by ensuring the confidence is
        # greater than the minimum confidence
        if confidence > 0.5:
            # compute the (x, y)-coordinates of the bounding box for
            # the object
            box = detections[0, 0, i, 3:7] * np.array([w, h, w, h])
            (startX, startY, endX, endY) = box.astype("int")

            # ensure the bounding boxes fall within the dimensions of
            # the frame
            (startX, startY) = (max(0, startX), max(0, startY))
            (endX, endY) = (min(w - 1, endX), min(h - 1, endY))

            # extract the face ROI, convert it from BGR to RGB channel
            # ordering, resize it to 224x224, and preprocess it
            face = frame[startY:endY, startX:endX]
            face = cv2.cvtColor(face, cv2.COLOR_BGR2RGB)
            face = cv2.resize(face, (224, 224))

```

```

        face = img_to_array(face)
        face = preprocess_input(face)

        # add the face and bounding boxes to their respective
        # lists
        faces.append(face)
        locs.append((startX, startY, endX, endY))

# only make a predictions if at least one face was detected
if len(faces) > 0:
    # for faster inference we'll make batch predictions on *all*
    # faces at the same time rather than one-by-one predictions
    # in the above `for` loop
    faces = np.array(faces, dtype="float32")
    preds = maskNet.predict(faces, batch_size=32)

# return a 2-tuple of the face locations and their corresponding
# locations
return (locs, preds)

def main():
    # load our serialized face detector model from disk
    prototxtPath = r"/home/pi/Rasbery-
        Pi/Face_mask_detection/face_detector/deploy.prototxt"
    weightsPath = r"/home/pi/Rasbery-
        Pi/Face_mask_detection/face_detector/res10_300x300_ssd_iter_140000.c
        affemodel"
    faceNet = cv2.dnn.readNet(prototxtPath, weightsPath)

    # load the face mask detector model from disk
    maskNet = load_model("/home/pi/Rasbery-
        Pi/Face_mask_detection/mask_detector.model")

    # initialize the video stream
    print("[INFO] starting video stream...")
    vs = VideoStream(src=0).start()

    # initialize mask and withoutMask
    mask = 0
    withoutMask = 0.01
    # loop over the frames from the video stream
    # while True:
    t_end = time.time() + 10
    while time.time() < t_end:
        # grab the frame from the threaded video stream and resize it
        # to have a maximum width of 400 pixels
        frame = vs.read()
        frame = imutils.resize(frame, width=400)

```



```

# detect faces in the frame and determine if they are wearing a
# face mask or not
(locs, preds) = detect_and_predict_mask(frame, faceNet, maskNet)

# loop over the detected face locations and their corresponding
# locations
for (box, pred) in zip(locs, preds):
    # unpack the bounding box and predictions
    (startX, startY, endX, endY) = box
    (mask, withoutMask) = pred

    # determine the class label and color we'll use to draw
    # the bounding box and text
    label = "Mask" if mask > withoutMask else "No Mask"
    color = (0, 255, 0) if label == "Mask" else (0, 0, 255)

    # include the probability in the label
    label = "{}: {:.2f}%".format(label, max(mask, withoutMask) *
    100)

    # display the label and bounding box rectangle on the output
    # frame
    cv2.putText(frame, label, (startX, startY - 10),
        cv2.FONT_HERSHEY_SIMPLEX, 0.45, color, 2)
    cv2.rectangle(frame, (startX, startY), (endX, endY), color, 2)

# show the output frame
cv2.imshow("Frame", frame)
key = cv2.waitKey(1) & 0xFF

# if the `q` key was pressed, break from the loop
if key == ord("q"):
    break

# do a bit of cleanup
cv2.destroyAllWindows()
vs.stop()

if mask > withoutMask:
    return 1
else:
    return 0

if __name__ == '__main__':
    main()

```

## MLX90614

- **Main**

```
import board
import busio as io
import adafruit_mlx90614

from time import sleep

def read_temp():
    i2c = io.I2C(board.SCL, board.SDA, frequency=100000)
    mlx = adafruit_mlx90614.MLX90614(i2c)

    targetTemp = "{:.2f}".format(mlx.object_temperature)
    tempInt = float(targetTemp)
    finalTemp = ((tempInt)*(9/5))+32

    sleep(1)

    print("Target Temperature: {:.2f} °F".format(finalTemp))
    return finalTemp

def main():
    read_temp()

if __name__ == '__main__':
    main()
```

## MAX30100

- **Library**

```
import smbus

INT_STATUS      = 0x00 # Which interrupts are tripped
INT_ENABLE      = 0x01 # Which interrupts are active
FIFO_WR_PTR     = 0x02 # Where data is being written
OVRFLOW_CTR     = 0x03 # Number of lost samples
FIFO_RD_PTR     = 0x04 # Where to read from
FIFO_DATA       = 0x05 # Output data buffer
MODE_CONFIG     = 0x06 # Control register
SPO2_CONFIG     = 0x07 # Oximetry settings
LED_CONFIG      = 0x09 # Pulse width and power of LEDs
TEMP_INTG       = 0x16 # Temperature value, whole number
TEMP_FRAC       = 0x17 # Temperature value, fraction
REV_ID          = 0xFE  # Part revision
PART_ID         = 0xFF  # Part ID, normally 0x11

I2C_ADDRESS     = 0x57 # I2C address of the MAX30100 device

PULSE_WIDTH = {
    200: 0,
    400: 1,
    800: 2,
    1600: 3,
}

SAMPLE_RATE = {
    50: 0,
    100: 1,
    167: 2,
    200: 3,
    400: 4,
    600: 5,
    800: 6,
    1000: 7,
}

LED_CURRENT = {
    0: 0,
    4.4: 1,
    7.6: 2,
    11.0: 3,
    14.2: 4,
    17.4: 5,
    20.8: 6,
```

```

    24.0: 7,
    27.1: 8,
    30.6: 9,
    33.8: 10,
    37.0: 11,
    40.2: 12,
    43.6: 13,
    46.8: 14,
    50.0: 15
}

def _get_valid(d, value):
    try:
        return d[value]
    except KeyError:
        raise KeyError("Value %s not valid, use one of: %s" % (value, ',
            '.join([str(s) for s in d.keys()])))

def _twos_complement(val, bits):
    """compute the 2's complement of int value val"""
    if (val & (1 << (bits - 1))) != 0: # if sign bit is set e.g., 8bit: 128-
255
        val = val - (1 << bits)
    return val

INTERRUPT_SPO2 = 0
INTERRUPT_HR = 1
INTERRUPT_TEMP = 2
INTERRUPT_FIFO = 3

MODE_HR = 0x02
MODE_SPO2 = 0x03

class MAX30100(object):

    def __init__(self,
                 i2c=None,
                 mode=MODE_HR,
                 sample_rate=100,
                 led_current_red=11.0,
                 led_current_ir=11.0,
                 pulse_width=1600,
                 max_buffer_len=10000
                 ):

        # Default to the standard I2C bus on Pi.
        self.i2c = i2c if i2c else smbus.SMBus(1)

```

```

self.set_mode(MODE_HR) # Trigger an initial temperature read.
self.set_led_current(led_current_red, led_current_ir)
self.set_spo_config(sample_rate, pulse_width)

# Reflectance data (latest update)
self.buffer_red = []
self.buffer_ir = []

self.max_buffer_len = max_buffer_len
self._interrupt = None

@property
def red(self):
    return self.buffer_red[-1] if self.buffer_red else None

@property
def ir(self):
    return self.buffer_ir[-1] if self.buffer_ir else None

def set_led_current(self, led_current_red=11.0, led_current_ir=11.0):
    # Validate the settings, convert to bit values.
    led_current_red = _get_valid(LED_CURRENT, led_current_red)
    led_current_ir = _get_valid(LED_CURRENT, led_current_ir)
    self.i2c.write_byte_data(I2C_ADDRESS, LED_CONFIG, (led_current_red
<< 4) | led_current_ir)

def set_mode(self, mode):
    reg = self.i2c.read_byte_data(I2C_ADDRESS, MODE_CONFIG)
    self.i2c.write_byte_data(I2C_ADDRESS, MODE_CONFIG, reg & 0x74) #
mask the SHDN bit
    self.i2c.write_byte_data(I2C_ADDRESS, MODE_CONFIG, reg | mode)

def set_spo_config(self, sample_rate=100, pulse_width=1600):
    reg = self.i2c.read_byte_data(I2C_ADDRESS, SPO2_CONFIG)
    reg = reg & 0xFC # Set LED pulsewidth to 00
    self.i2c.write_byte_data(I2C_ADDRESS, SPO2_CONFIG, reg |
pulse_width)

def enable_spo2(self):
    self.set_mode(MODE_SPO2)

def disable_spo2(self):
    self.set_mode(MODE_HR)

def enable_interrupt(self, interrupt_type):
    self.i2c.write_byte_data(I2C_ADDRESS, INT_ENABLE, (interrupt_type +
1)<<4)
    self.i2c.read_byte_data(I2C_ADDRESS, INT_STATUS)

```

```

def get_number_of_samples(self):
    write_ptr = self.i2c.read_byte_data(I2C_ADDRESS, FIFO_WR_PTR)
    read_ptr = self.i2c.read_byte_data(I2C_ADDRESS, FIFO_RD_PTR)
    return abs(16+write_ptr - read_ptr) % 16

def read_sensor(self):
    bytes = self.i2c.read_i2c_block_data(I2C_ADDRESS, FIFO_DATA, 4)
    # Add latest values.
    self.buffer_ir.append(bytes[0]<<8 | bytes[1])
    self.buffer_red.append(bytes[2]<<8 | bytes[3])
    # Crop our local FIFO buffer to length.
    self.buffer_red = self.buffer_red[-self.max_buffer_len:]
    self.buffer_ir = self.buffer_ir[-self.max_buffer_len:]

def shutdown(self):
    reg = self.i2c.read_byte_data(I2C_ADDRESS, MODE_CONFIG)
    self.i2c.write_byte_data(I2C_ADDRESS, MODE_CONFIG, reg | 0x80)

def reset(self):
    reg = self.i2c.read_byte_data(I2C_ADDRESS, MODE_CONFIG)
    self.i2c.write_byte_data(I2C_ADDRESS, MODE_CONFIG, reg | 0x40)

def refresh_temperature(self):
    reg = self.i2c.read_byte_data(I2C_ADDRESS, MODE_CONFIG)
    self.i2c.write_byte_data(I2C_ADDRESS, MODE_CONFIG, reg | (1 << 3))

def get_temperature(self):
    intg = _twos_complement(self.i2c.read_byte_data(I2C_ADDRESS,
    TEMP_INTG))
    frac = self.i2c.read_byte_data(I2C_ADDRESS, TEMP_FRAC)
    return intg + (frac * 0.0625)

def get_rev_id(self):
    return self.i2c.read_byte_data(I2C_ADDRESS, REV_ID)

def get_part_id(self):
    return self.i2c.read_byte_data(I2C_ADDRESS, PART_ID)

def get_registers(self):
    return {
        "INT_STATUS": self.i2c.read_byte_data(I2C_ADDRESS, INT_STATUS),
        "INT_ENABLE": self.i2c.read_byte_data(I2C_ADDRESS, INT_ENABLE),
        "FIFO_WR_PTR": self.i2c.read_byte_data(I2C_ADDRESS,
        FIFO_WR_PTR),
        "OVRFLOW_CTR": self.i2c.read_byte_data(I2C_ADDRESS,
        OVRFLOW_CTR),
    }

```

```

        "FIFO_RD_PTR": self.i2c.read_byte_data(I2C_ADDRESS,
                                                FIFO_RD_PTR),
        "FIFO_DATA": self.i2c.read_byte_data(I2C_ADDRESS, FIFO_DATA),
        "MODE_CONFIG": self.i2c.read_byte_data(I2C_ADDRESS,
                                                MODE_CONFIG),
        "SPO2_CONFIG": self.i2c.read_byte_data(I2C_ADDRESS,
                                                SPO2_CONFIG),
        "LED_CONFIG": self.i2c.read_byte_data(I2C_ADDRESS, LED_CONFIG),
        "TEMP_INTG": self.i2c.read_byte_data(I2C_ADDRESS, TEMP_INTG),
        "TEMP_FRAC": self.i2c.read_byte_data(I2C_ADDRESS, TEMP_FRAC),
        "REV_ID": self.i2c.read_byte_data(I2C_ADDRESS, REV_ID),
        "PART_ID": self.i2c.read_byte_data(I2C_ADDRESS, PART_ID),
    }
}

```

- **Main**

```

# -*- coding: utf-8 -*-
import time
from MAX30100 import max30100
#import max30100

def read_spo2():
    mx30 = max30100.MAX30100()
    mx30.enable_spo2()

    t_end = time.time() + 15
    while time.time() < t_end:
        mx30.read_sensor()

        mx30.ir, mx30.red

        hb = int(mx30.ir / 100)
        spo2 = int((mx30.red / 100)+10)

        # if mx30.ir != mx30.buffer_ir :
        #     print("Pulse:",hb);
        # if mx30.red != mx30.buffer_red:
        #     print("SPO2:",spo2);
        #time.sleep(1)

    if mx30.red != mx30.buffer_red:
        print("SPO2:", spo2);
    return spo2

def main():
    read_spo2()

if __name__ == '__main__':
    main()

```

## Firestore

- **Realtime data upload**

```
import pyrebase
import firebase
from argparse import ArgumentParser

#Initialize Firestore
firebaseConfig={
    'apiKey': "AIzaSyCJ7v732hAQ0mHs2CMx2E1U5D__fLdiPhE",
    'authDomain': "entry-system-e981c.firebaseio.com",
    'databaseURL': "https://entry-system-e981c.firebaseio.com",
    'projectId': "entry-system-e981c",
    'storageBucket': "entry-system-e981c.appspot.com",
    'messagingSenderId': "960985398700",
    'appId': "1:960985398700:web:f7dba44a44d95851a6ce09",
    'measurementId': "G-MHY9RV1941"
}

firebase = pyrebase.initialize_app(firebaseConfig)
db = firebase.database()

def upload_data(data):
    # push data
    vals = list(data.values())
    data.pop("ID")
    db.child("Users").child(vals[0]).push(data)

def main(data):
    upload_data(data)

if __name__ == '__main__':
    main()
```



## Indicator

- **LED switch on/off**

```
from gpiozero import LED
from time import sleep

def led(risk):
    if risk == 'No Risk':
        green = LED(12)
        green.on()
        sleep(5)
        green.off()

    if risk == 'Moderate Risk':
        yellow = LED(16)
        yellow.on()
        sleep(5)
        yellow.off()

    if risk == 'High Risk':
        red = LED(20)
        red.on()
        sleep(5)
        red.off()

def led_try():
    blue = LED(21)
    blue.on()
    sleep(2)
    blue.off()

def main():
    led(risk)

if __name__ == '__main__':
    main()
```

## Survey Data

S/L	Do you regularly visit your University/ Workplace ?	Do you have to go through a security screening?	What type of measures do they take before allowing you in?	Do you think it is a lengthy process?	Would you like an automated system that checks masks, oxygen saturation and body temperature all at once?	Will you be reluctant to provide your health data to the system?	Any suggestions for enhancements if the above system is implemented?
1	Yes	Yes	-Mask detection -Temperature Detection	Yes	Yes	No	
2	Yes	Yes	-Mask detection -Temperature Detection	No	Yes	Yes	
3	No	Yes	-Mask detection -Temperature Detection	No	Yes	Yes	
4	Yes	Yes	-Mask detection -Temperature Detection	Yes	Yes	Yes	
5	No	No	-Temperature Detection	No	Yes	Yes	
6	Yes	Yes	-Temperature Detection	Yes	Maybe	No	
7	Yes	Yes	-Mask detection	No	No	No	
8	Yes	Yes	-Mask detection -Temperature Detection	No	Maybe	Yes	Secrecy of Individuals being possibly covid positive for prevention of turmoil among others going through the process.
9	Yes	No	-Mask detection	No	Yes	Yes	
10	No	Yes	-Mask detection -Temperature Detection	No	Yes	Yes	
11	No	Yes	-Mask detection -Temperature Detection	No	Maybe	Yes	
12	No	Yes	-Temperature Detection	No	No	Yes	

13	No	Yes	-Mask detection -Temperature Detection	No	Yes	Yes	
14	No	Yes	-Mask detection -Temperature Detection -Oxygen saturation Detection	No	Maybe	No	
15	No	No	-Mask detection	No	Yes	Yes	
16	Yes	No	-Temperature Detection	No	Yes	Yes	
17	No	Yes	-Mask detection -Temperature Detection	No	Yes	Yes	All good
18	No	No	-Mask detection	Yes	Yes	Yes	
19	Yes	Yes	-Mask detection -Temperature Detection	Yes	Yes	Yes	
20	No		-Mask detection	No	Yes	Yes	
21	No	Yes	-Mask detection -Temperature Detection	No	Yes	No	
22	No				Maybe	No	
23	No	Yes	-Mask detection	Yes	Yes	Yes	
24	No	Yes	-Temperature Detection	No	Yes	No	
25	Yes	Yes	-Mask detection -Temperature Detection	No	Yes	Yes	.
26	No	Yes	-Mask detection -Temperature Detection	No	Yes	Yes	No
27	No	Yes	-Mask detection -Temperature Detection	No	Yes	Yes	
28	Yes	Yes	-Mask detection -Temperature Detection	No	Yes	Yes	
29	Yes	Yes	-Mask detection	No	Yes	Yes	
30	No	Yes	-Mask detection -Temperature Detection	No	Yes	No	

31	Yes	No	-Mask detection -Temperature Detection -Oxygen saturation Detection	No	Yes	Yes	
32	Yes	No	Mask detection	No	Maybe	Yes	No, I am tired of Covid. I just want it to disappear with this system.
33	No	No		No	Yes	No	
34	No	No	-Mask detection	No	Yes	Yes	
35	Yes	Yes	-Mask detection	Yes	Yes	No	
36	Yes	Yes	-Mask detection -Temperature Detection	Yes	Yes	Yes	It will be more effective.
37	No	No		Yes	Maybe	Yes	Not at all
38	Yes	Yes	-Mask detection -Temperature Detection	No	Maybe	Yes	

Do you regularly visit your University/Workplace?

38 responses

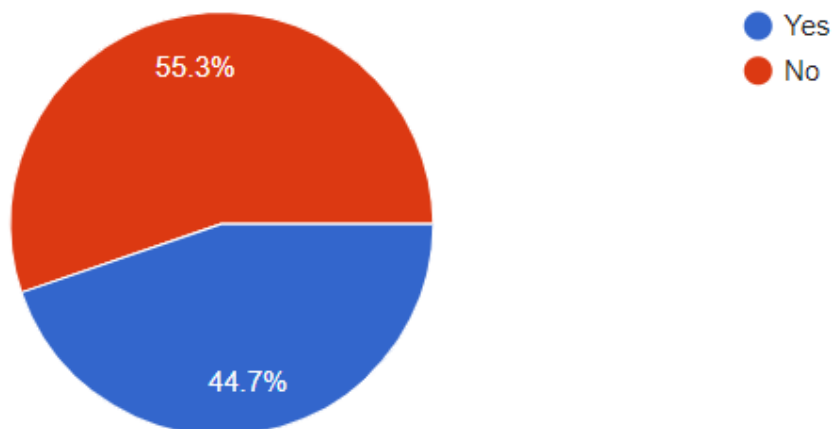

## Do you have to go through a security screening?

36 responses

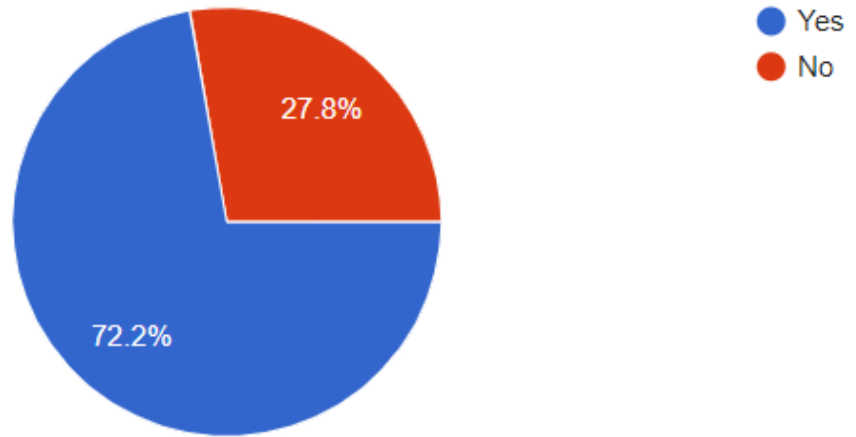

## What type of measures do they take before allowing you in?

37 responses

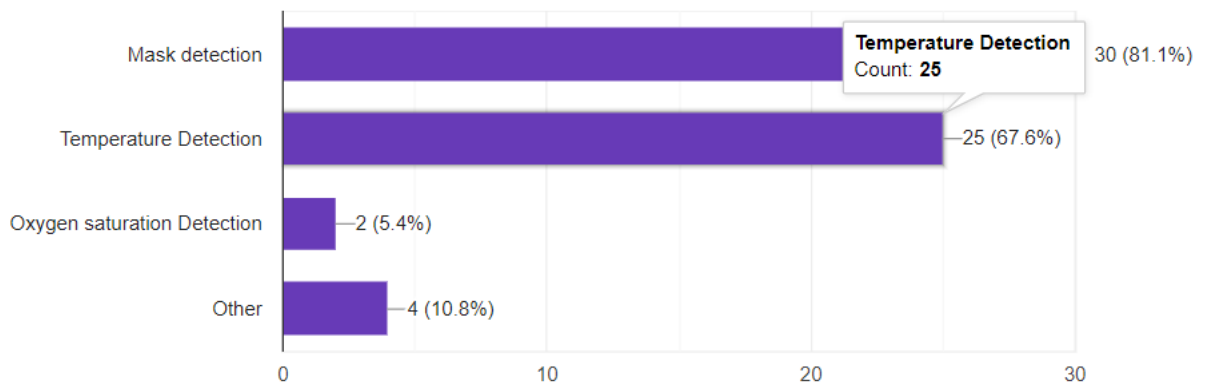

### Do you think it is a lengthy process?

37 responses

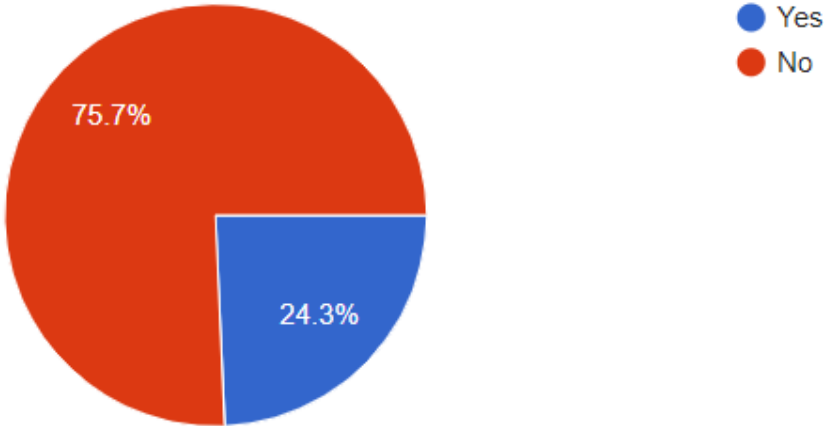

### Would you like an automated system that checks masks, oxygen saturation, and body temperature all at once?

38 responses

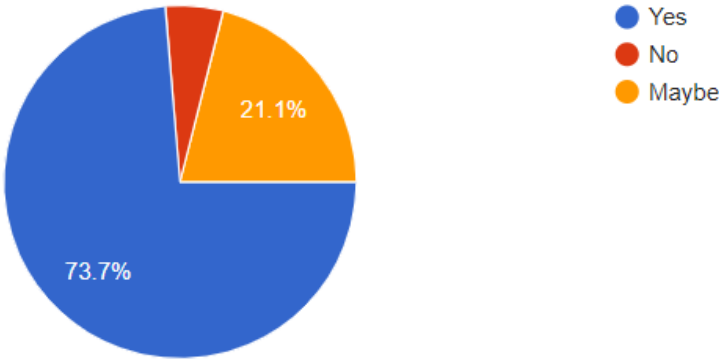

Will you be reluctant to provide your health datas to the system?

38 responses

