

# LOAD SHARING BETWEEN HYBRID SOURCES IN HOUSEHOLD APPLICATIONS

By

Fahim Tawfiq Khan

ID: 19121119

Omar Fahim

ID: 19121095

Md. Arafat Rahman

ID: 19121090

Nazmun Nahar Khan Meem

ID: 19121109

A Final Year Design Project (FYDP) submitted to the Department of Electrical and Electronic Engineering in partial fulfillment of the requirements for the degree of B.Sc. in Electrical and Electronic Engineering

Department of Electrical and Electronic Engineering  
Brac University  
May 2023

© 2023 Brac University  
All rights reserved.

# LOAD SHARING BETWEEN HYBRID SOURCES IN HOUSEHOLD APPLICATIONS

By

Fahim Tawfiq Khan

ID: 19121119

Omar Fahim

ID: 19121095

Md. Arafat Rahman

ID: 19121090

Nazmun Nahar Khan Meem

ID: 19121109

A Final Year Design Project (FYDP) submitted to the Department of Electrical and Electronic Engineering in partial fulfillment of the requirements for the degree of B.Sc. in Electrical and Electronic Engineering

## **Academic Technical Committee (ATC) Panel Member:**

Dr. Abu S.M. Mohsin, PhD

Associate Professor, Department of EEE, BRAC University

Taiyeb Hasan Sakib

Lecturer, Department of EEE, BRAC University

Ehsanul Karim

Lecturer, Department of EEE, BRAC University

Electrical and Electronic Engineering

Brac University

May 2023

© 2023 Brac University

All rights reserved.

## Declaration

It is hereby declared that

1. The Final Year Design Project (FYDP) submitted is my/our own original work while completing degree at Brac University.
2. The Final Year Design Project (FYDP) does not contain material previously published or written by a third party, except where this is appropriately cited through full and accurate referencing.
3. The Final Year Design Project (FYDP) does not contain material which has been accepted, or submitted, for any other degree or diploma at a university or other institution.
4. I/We have acknowledged all main sources of help.

### Student's Full Name & Signature:

---

**Fahim Tawfiq Khan**  
19121119

---

**Md. Arafat Rahman**  
19121090

---

**Nazmun Nahar Khan Meem**  
19121100

---

**Omar Fahim**  
19121095

## Approval

The Final Year Design Project (FYDP) titled “Load sharing Between Hybrid Sources in Household Applications.” submitted by

1. Nazmun Nahar Khan Meem (19121109)
2. Fahim Tawfiq Khan (19121119)
3. Md.Arafat Rahman (19121090)
4. Omar Fahim (19121095)

of Spring, 2023 has been accepted as satisfactory in partial fulfillment of the requirement for the degree of B.Sc. in Electrical and Electronic Engineering on 27<sup>th</sup> April, 2023.

### Examining Committee:

Academic Technical  
Committee (ATC):  
(Chair)

---

Abu S.M. Mohsin, PhD  
Associate Professor, Department of EEE  
BRAC University

Final Year Design Project  
Coordination Committee:  
(Chair)

---

Abu S.M. Mohsin, PhD  
Associate Professor, Department of EEE  
BRAC University

Department Chair:

---

Md. Mosaddequr Rahman, Ph.D.  
Professor and Chairperson, Department of EEE  
Brac University

## **Ethics Statement**

We hereby certify that the project title "Load Sharing Between Hybrid Sources In Household Application" complies with the requirements for the Final Year Design Project (FYDP). This project was created by our team, and all supplementary sources used for analysis, literature research, and data collecting have been properly referenced. We have received assistance from the university and our supervisors in putting the project's contents into practice.

## **Abstract/ Executive Summary**

The increasing demand of renewable energy in our day-to-day life leads us to contemplate methods of incorporating renewable sources with conventional grid as several hybrid systems can be designed to meet the power demand of household loads. A typical hybrid system can be a combination of renewable sources only or it can be a combination of both renewable and conventional power system. Since, two or more sources are combinedly working hence loads are shared between the loads. To facilitate the load sharing scheme, a switching mechanism is required that will control the sources and the loads as well.

In our project, we have designed a system that works to ensure dynamic load sharing for a 1200 square feet apartment utilizing grid and solar energy controlled by an automated transfer switch (ATS) based on the availability of sources, loads demand, and the battery state of charge (SOC) so that we can reduce dependency on fossil fuel, lower electricity bill and guarantee uninterrupted supply of power for our homes. The household loads will be shared by both solar and grid power depending upon the load demand and the availability of these sources.

## **Acknowledgement**

We would like to extend our gratitude to Dr.Abu S.M. Mohsin, PhD, the chair of our committee, for his tremendous assistance and thorough examination of the project. Additionally, we are appreciative of Taiyeb Hasan Sakib, Lecturer, and Ehsanul Karim, Lecturer at Brac University, who offered advice and suggested many conventions to improve the project.

## Table of Contents

|   |    |
|---|----|
| <b>Chapter 1: Introduction- [CO1, CO2, CO10]</b> .....                                    | 9  |
| <b>Chapter 2: Project Design Approach [CO5, CO6]</b> .....                                | 21 |
| <b>Chapter 3: Use of Modern Engineering and IT Tool. [CO9]</b> .....                      | 42 |
| <b>Chapter 4: Optimization of Multiple Design and Finding the Optimal Solution. [CO7]</b> | 46 |
| <b>Chapter 5: Completion of Final Design and Validation. [CO8]</b> .....                  | 53 |
| <b>Chapter 6: Impact Analysis and Project Sustainability. [CO3, CO4]</b> .....            | 61 |
| <b>Chapter 7: Engineering Project Management. [CO11, CO14]</b> .....                      | 69 |
| <b>Chapter 8: Economical Analysis. [CO12]</b> .....                                       | 76 |
| <b>Chapter 9: Ethics and Professional Responsibilities CO13, CO2</b> .....                | 83 |
| <b>Chapter 10: Conclusion and Future Work</b> .....                                       | 91 |
| <b>Chapter 11: Identification of Complex Engineering Problems and Activities</b> .....    | 92 |
| <b>Attributes of Complex Engineering Problems (EP)</b> .....                              | 92 |
| <b>Attributes of Complex Engineering Activities (EA)</b> .....                            | 93 |
| <b>References</b> .....   | 95 |



## Chapter 1: Introduction- [CO1, CO2, CO10]

### 1.1 Introduction

Hybridization techniques are utilized today to increase power density and fuel efficiency since they offer a fantastic opportunity to mix various power sources and are the best extension to conventional sources. Its appropriate application and energy storage will save operating expenses and improve system efficiency. This project represents a load-sharing method that ensures continuous power supply using renewable and conventional sources for household applications. Solar panels are used as renewable sources along with grid energy. To make the greatest possible use of solar energy, a backup battery is charged besides the solar battery. An automatic transfer switch (ATS) is used for uninterrupted power supply as an effective idea of load-sharing technique. Simulations and optimizations studies are conducted to show the viability of the proposed design. The proposed system will be able to supply electricity to small loads, large loads, variable loads according to load demands for household applications with the aid of hybrid sources and integrated structure.

#### 1.1.1 Problem Statement

Bangladesh is a developing country. Our economy is one of the fastest growing economies in the world. As a result, every year we need a huge amount of electricity for our industries, households, agricultural sectors, businesses and many other sectors. We have a total electricity demand of approximately 20000 megawatts every year in recent years. [1] No doubt its increasing day by day. To meet this huge electricity demand, we are using a great amount of fossil fuels for electricity generation. The percentages of sources for electricity generation are; Natural Gas – 66.8%, Other Fossil Fuels – 24.6%, Coal – 7.3%, Solar – 0.7%, Hydro – 0.7%. [2] From this ratio we can see that we have to depend on fossil fuels.

We all know that burning fossil fuels causes CO<sub>2</sub> emissions and its very harmful for our environment. Not only that but also, for fossil fuels we have to depend on other countries. Rate of fossil fuels can be manipulated by international politics, the rate of dollar, international trade, diplomatic issues and many other factors. For example; when a war started the dollar rate goes high and the international market became unstable. As a result, the price of fossil fuels goes very high and we have to pay a lot of money for fossil fuels as we are generating most of our electricity from fossil fuels. For this reason, our government had to increase electricity prices. Government forced to stop many HFO based power plants. As a result, we had to face unbearable load shedding. This thing directly affects our national economy. It was true for the Iraq war, Afghanistan war, Iran issue, Syria issue and many more. It happens for geopolitics, regional politics, any kind of natural calamities or man-made problems. So, we are trying to solve this problem with our limited resources.

Bangladesh has a suitable geographical position for solar irradiation. [3] By keeping this thing in mind, the government of Bangladesh is encouraging solar based energy systems. Solar Home System (SHS), Solar Power Plant, Rooftop Solar Projects are some examples of them. The government takes a lot of initiative for developing solar based projects. [3] After a lot of analysis, we came up with SHS for solving our electricity problem. We added a rooftop solar system with SHS. Now-a-days, the SHS is capable of providing electricity to about 18 million people of Bangladesh which is 11% of total population. [3] So, it's a huge opportunity to take the chance to solve the electricity problem. Moreover, solar energy is free energy and green energy. We can also add other renewable sources as our energy source. For instance, Biomass energy, Hydrogen Fuel, Wind Energy are some examples of renewable energy. Collectively, we can add these energy systems and we can make a hybrid home energy system.

So, we can contribute with our project to meet the increasing energy demand due to rapid urbanization, mechanization, and industrialization for our fast-growing economy.

### **1.1.2 Background Study**

The call for renewable energy generation is getting louder as a massive crisis of fossil fuel is looming due its excessive use in power generation and transportation. As the world is already reeling from the consequences of the Russia-Ukraine war, a shift in energy management policy is therefore imminent as the developed countries are going all out for sustainable power generation. As a developing country, we ought to have a sustainable energy management policy which must emphasize renewable energy. Renewable energy sources come in many forms such as solar energy, geo-thermal energy, wind energy, hydro energy etc. For our country's context, geo-thermal energy has almost no prospect since there is no significant volcanic activity under its mantle. Also, since the country mostly consisted of low-lying lands, the prospect of hydro energy is very little. Although an existing hydro power plant in Kaptai, Rangamati is operational, the installed capacity is only around 230MW [1]. Granted, the plant covers almost 777 km<sup>2</sup> land area [1]. This leaves us with only two viable options that are solar and wind energy. With an average wind speed of over 5 m/s [2] in coastal areas, there is a decent prospect of commercial wind energy generation in near future. Bangladesh government has already undertaken some major wind power plant projects that are said to be commissioned by 2023 [3]. Last but not the least, solar energy is the most abundant renewable energy source available in the country. Bangladesh receives an average 4.64 kWh/m<sup>2</sup> [4] solar radiation per day which is a good amount for electricity generation. However, solar power plants require a huge installation area. A 1 MW solar power plant occupies around 4 acres land area [5]. For a small country like Bangladesh, the cost for solar power generations is significantly high. That said, solar generation can be implemented in smaller scales such as mounting panels on roof-tops. These smaller scale solar home projects are gaining popularity as thousands of rural households are electrified using solar panels only. Moreover, these projects are cost efficient since the materials are cheaper and maintenance cost is also low. As a result, a huge population of the

underprivileged communities are benefiting from solar home projects. Having said that, our aim in this project is to design a hybrid system that would have a combination of both solar and conventional grid in order to power household appliances. By implementing the project, we are hoping to reduce the cost of electricity as we shall be utilizing renewable sources which are fortunately quite abundant in nature.

Household load sharing can have a significant impact on annual electricity bill reduction as well as minimizing dependency on fossil fuel. Using battery storage for solar energy reduces peak power demand by 8-32% and peak power injection by 5-42% [6]. Shared battery storage for photovoltaic energy can increase self-consumption by 19% and increase self-sufficiency by 12% if implemented in apartment buildings [7].

This problem has been covered in a number of studies, including load sharing between ac sources and a generator [8] by ATS, load sharing between conventional and solar energy regulated by an ATS [9] where solar energy will be prioritized, and solar energy alone [10]. A switch called ATS is constructed from a number of relays. This system accepts input from power sources and makes sure that loads receive consistent power supply. It shifts the power supply to another source and ensures power delivery when one of the power sources is unavailable or fails to give enough power to loads [8].

First and foremost, it's crucial to use hybrid sources to provide a constant power supply. As a result, we guarantee the utilization of hybrid energy sources and put a focus on renewable energy sources for load sharing. Furthermore, because we use two batteries at once, our project is a little bit different from those. In order to maintain a backup storage system for continuous power delivery and to prolong battery lifetime due to decreased daily load strain using 2 batteries at a time is important.

Our project will have provision for utilizing solar energy from battery storage as well as use grid energy if demand increases. The battery SOC will be monitored by a control mechanism which will control battery charge, discharge and grid incorporation.

We have simulated two design approaches to analyze and compare between several parameters. Additionally, we have simulated another design which consists of wind and hydrogen fuel contrary to our original design considerations. Combining all the results based on certain parameters we have decided our optimal design approach. To perform simulation and optimization tasks, we have taken assistance from some design tools that are entirely dedicated to perform these tasks. The first software we have used to design our system is MATLAB Simulink. We have constructed our circuit in Simulink as it provides various design blocks and there is also provision for writing control algorithms through the MATLAB function. There is a similar software named Proteus which can also be used to design this particular system. However, unlike Simulink Proteus doesn't have a variety of blocks. In Simulink, we have used power electronics and a power system block where we have found several components. We need to design our circuit. Furthermore, our design is based on monitoring battery SOC which can be easily done with Simulink. Considering all the pros and cons, MATLAB seemed an easy pick for us and we could successfully design our circuit as per the system requirements.

Next, we had to use an optimization software to select the optimal design, perform cost analysis and load forecasting. As we have researched, there are two software commonly available for this purpose which are HOMER Pro and PVsyst. We have tried simulating our design in both software. Although PVsyst offers all the features Homer Pro does, Homer Pro offers more flexibility in component selection. There are a wide range of components available from where we have selected our desired ones that perform best as per our requirements.

### **1.1.3 Literature Gap**

Our project aims to cut down electricity cost by consumer end therefore it is imperative to design a system that would be both cost effective and sustainable. That is why we have tried to incorporate both grid and solar in a way so that the system requires less converters which are very expensive to come by. The literature we have come across mainly focused on load sharing through a common DC bus where back-to-back converters were required to match the reference voltage. As we have simulated such systems, we have observed that when solar energy production slumps, the system starts back flowing current through the solar panels. To avoid such circumstances, we have used separate battery combinations in our design and implemented a control mechanism to establish load sharing.

Once more, using hybrid sources to deliver a steady supply of electricity is essential. The majority of the literature uses one battery as backup storage to complete the design. However, a battery's lifespan will be shortened if it continuously maintains the loads. Again, the status of charge will continuously decline as the battery is depleted. The charging pace will be slow if we charge the same battery at the same time. Battery power will be low and unable to provide continuous power supply if the grid is down for a prolonged period of time. We are utilizing two batteries to get around this problem. The second battery will be charged after the first one has been discharged. Therefore, the rate of charging will be quicker than before. Additionally, a constant power source may be guaranteed, and the battery will last longer than in earlier projects.

Another primary goal of our project is designing an ATS system which is a self-operating system controlled by specific control logic and ensures uninterrupted power supply by switching one of two power sources connected to loads. In most of the literature solar inverters are being used for load management systems. But their controlling mechanism is not disclosed there. So, we design an ATS based on our demand such as load demand, availability of sources and SOC of the battery.

### **1.1.4 Relevance to current and future Industry**

Due to advancements in renewable energy technology and the ensuing increase in the price of petroleum products, hybrid renewable energy systems are becoming more and more common power systems for supplying electricity in remote places. Worldwide people are using renewable energy sources along with the grid for household and industrial purposes. For example, 2019 saw the installation of a \$5 million hybrid system in western Minnesota. By feeding 500 kW of solar energy via a 2 MW wind turbine's inverter, the capacity factor is raised and annual expenditures are cut by \$150,000. Purchase agreements limit the local distributor's self-generation to a maximum of 5% [11]. As a result, the wind turbine would produce higher output during the winter, while the solar panels would provide their maximum production during the summer. Variable solar PV production can be buffered by battery storage. However, there are significant daily changes in productivity as well as seasonal variations in many locations. The battery aids in matching power to load. Additionally, a hybrid solar inverter enables the storage of inexpensive electricity derived from low-cost tariffs [12].

Hybrid energy sources can also be used for sharing loads to microgrid. Although a microgrid could be made up of any sort of energy generation, it is increasingly typical to find batteries and a relatively high mix of renewable energy sources in contemporary microgrids. The microgrid industry is predicted to expand at a compound annual growth rate (CAGR) of 27% between 2021 and 2027, reaching a \$33 billion global valuation which indicates a bright future of hybrid energy sources for sharing loads [13].

## **1.2 Objectives, Requirements, Specification and constant**

### **1.2.1 Objectives**

Our objective is to design a hybrid power system for household applications so that the loads can be shared between conventional grid and renewable sources. Hence, we are aiming to reduce our dependence on traditional fossil fuel-based sources and utilize renewable resources. Renewable energy sources are essential to sustainable energy. They generally strengthen energy security and emit far fewer greenhouse gasses than fossil fuels. So, our target is to load share by maximum use of green energy sources and least use of conventional sources. For example, we use conventional grid energy in our house. As a result, 100% loads are shared by the grid. But if we use any kind of renewable energy along with the grid then the load will be shared 60:40 or 30:70 or by following any other ratio. Now Hybrid sources can share load at the same time or they can share load depending on their availability. We can ensure both kinds of load sharing by controlling hybrid sources [8]. For instance, after matching the frequency of hybrid sources, we can make them ready to share load at the same time or we can store them firstly in battery and then discharge it to loads or we can share load by renewable energy source during its available period and rest of the time by conventional source. To alternate the

conventional and renewable sources we try to design an automatic transfer switch which can connect the available sources to power up the loads depending on their availability. As we are focusing on load sharing, the electricity bill for grid or fuel cell will also be reduced. But there are installation costs of PV panels or wind turbines and others. But after going through literature review, talking with the user of renewable energy and working with different software, it is clear that after 5 to 6 years cost will be minimized and electricity bill will be reduced for the next 10 to 12 years.

## 1.2.2 Functional and Nonfunctional Requirements

The requirements have been divided into two categories: functional requirements and nonfunctional requirements.

TABLE 1: Functional Requirements.

|                            |  |
|----------------------------|--|
| Automated Load Sharing     | The system has an automated load sharing system. A controlling system has been designed for automated load sharing. This controlling system decides whether the load will be shared by renewable sources or conventional sources depending on their availability and SOC of the battery. |
| Automated Battery Charging | The system has an automated battery charging mechanism by which the battery can be charged up from green energy according to its (SOC).  |
| Automated Transfer Switch  | The system has an automated transfer switch to ensure uninterrupted power supply to the loads depending on load demand, availability of energy sources and SOC of the battery.   |
| Installation Area          | Solar panels can be installed in the roof-top area to get more sunlight and the modular nature of the solar PV system makes them highly adaptable for use on roof-top.   |

## Non-Functional Requirements:

TABLE 2: Non-Functional Requirements.

|                                  |   |
|----------------------------------|---|
| Utilize maximum renewable energy | To utilize the maximum renewable energy, we are using a storage system. We can use this stored energy as a backup source and discharge it to load during an unavailable period of green energy. |
| Cost efficiency & performance    | By designing an optimum controlling system, we can enhance the performance of the system hence, electricity bills can be reduced due to less dependency on conventional sources.                |
| C/C++ programmed microcontroller | There are multiple microcontrollers available in our country such as C or C++ language based, we can use any of these microcontrollers according to their cost.                                 |

## 1.2.3 Specifications

### Load Calculation:

TABLE 3: Load calculation for real system

| Appliances           | Quantity | Power (Watts) | Hours per day | Kwh/d |
|----------------------|----------|---------------|---------------|-------|
| CFL Bulb             | 5        | 18            | 12            | 1080  |
| TV-LCD               | 1        | 150           | 4             | 600   |
| Laptop               | 1        | 100           | 4             | 400   |
| Smart phone recharge | 1        | 6             | 3             | 18    |
| Ceiling Fan          | 4        | 75            | 16            | 4800  |
| Router               | 1        | 7             | 24            | 168   |

Total Peak load = 653 W

Total Kwh = 7066 Kwh

TABLE 4: System & component level specifications for both the real and prototype system

| Real System                |   | Prototype   |
|----------------------------|---|---|
| System level               | Component level   | Component level   |
| Photovoltaic energy source | 12V 295W<br>Mono crystalline panels   | 18V 10W solar panel<br>Greenland solar<br>Module Type: Poly   |
| Energy storage             | 12V 134 AH battery  | 12V 9 AH battery  |
| DC-AC converter            | 12V 384W inverter   | 12V 220W inverter   |
| DC-DC converter            | 12V Solar charge controller   | 12V Solar charge controller   |
| Auto Transfer Switch       | <ul style="list-style-type: none"> <li>● 5v 10A relay</li> <li>● Arduino nano Microcontroller</li> <li>● 100 Ohms resistor</li> <li>● 470 uF capacitor</li> <li>● Push switch</li> <li>● BC 547 Transistor</li> <li>● 5k variable resistor</li> <li>● 300v 30A 2 pin terminal block</li> <li>● Wires with male &amp; female header</li> </ul> | <ul style="list-style-type: none"> <li>● 5v 10A relay</li> <li>● Arduino nano Microcontroller</li> <li>● 100 Ohms resistor</li> <li>● 470 uF capacitor</li> <li>● Push switch</li> <li>● BC 547 Transistor</li> <li>● 5k variable resistor</li> <li>● 300v 30A 2 pin terminal block</li> <li>● Wires with male &amp; female header</li> </ul> |



### **1.2.3 Technical and Non-technical consideration and constraint in design process**

Irradiation of solar energy is not constant. Depending on various times of the day it varies. Again, it mostly depends on weather conditions. If the weather is gloomy then the irradiance will be lower than the other day. As we are storing solar energy in batteries and not using any generator as an alternate supply system, we may face some problems when load demand increases. Furthermore, there is loss of power in auxiliary devices such as inverters. If grid energy is not available, we shall face an autonomous dead situation. Again, we are using batteries as storage systems and they are obviously heavy. We need to consider these types of technical and non-technical constraints at the time of completing this design.

### **1.2.4 Applicable compliance, standards, and codes**

#### **Applicable standards:**

The Sustainable and Renewable Energy Development Authority (SREDA) has mandated that PV modules imported into the country must comply with the International Electrotechnical Commission standards IEC 61215:2016, IEC 60904-1:2013, and IEC 60904-9:2013. SREDA has also specified that batteries and charge controllers should meet the standards outlined in IEC 61427-1:2016, while wind turbines should comply with the requirements of IEC 61400.[14]

- The IEC 61215-1:2019 outlines the certification and approval requirements for the design of photovoltaic (PV) modules used for long-term operation on land. This standard applies to all flat plate module types, including thin-film and crystalline silicon modules. Its purpose is to test the module's electrical and thermal properties and, within realistic time and cost limitations, demonstrate that the module can withstand extended exposure to specific climates outlined in the scope.[14]
- The IEC 61215-1:2019 outlines the certification and approval requirements for the design of photovoltaic (PV) modules used for long-term operation on land. This standard applies to all flat plate module types, including thin-film and crystalline silicon modules. Its purpose is to test the module's electrical and thermal properties and, within realistic time and cost limitations, demonstrate that the module can withstand extended exposure to specific climates outlined in the scope.[14]
- The International Electrotechnical Commission (IEC) has established key design requirements for wind turbines in IEC 61400-1:2019 to ensure their structural stability. The purpose of this standard is to provide adequate protection against all potential threats throughout the expected lifespan of the wind turbine. This standard covers all aspects of a wind turbine, including its support structures, internal electrical and

mechanical systems, and control and protection mechanisms. This material is applicable to wind turbines of any size. For small wind turbines, IEC 61400-2 can be utilized.[15]

- The IEC 61427-1:2013 is part of a collection of guidelines that contains general information on the requirements for secondary batteries in photovoltaic energy systems (PVES) and the standard test procedures used to verify their performance. This particular section focuses on the batteries and cells used in off-grid photovoltaic applications. This standard can be applied to all types of secondary batteries.[14]

### Applicable Codes:

- **IEEE 937**
  - IEEE Recommended Practice for Installation and Maintenance of Lead-Acid Batteries for Photovoltaic Systems.
    - **Description:** IEEE 937 is a recommended practice for the installation and maintenance of lead-acid batteries used in photovoltaic systems, providing guidance on proper installation, operation, and maintenance practices to ensure optimal battery performance and longevity.
- **IEEE 1013**
  - IEEE Recommended Practice for Sizing Lead-Acid Batteries for Stand-Alone Photovoltaic Systems.
    - **Description:** IEEE 1013 is a recommended practice for sizing lead-acid batteries used in stand-alone photovoltaic systems, providing guidance on battery selection and capacity planning.
- **IEEE 1361**
  - IEEE Guide for Selection, Charging, Test and Evaluation of Lead-Acid Batteries Used in Stand-Alone Photovoltaic Systems.
    - **Description:** Selecting correct number of modules for inverter and derating arrays for less than optimal air flow, tilt & azimuth angles.
- **IEEE 1547**
  - IEEE Standard for Interconnection and Interoperability of Distributed Energy Resources with Associated Electric Power Systems Interfaces.
    - **Description:** This document provides a uniform standard for the interconnection and interoperability of distributed energy resources with electric power systems. It provides requirements relevant to the interconnection and interoperability performance, operation and testing, and, to safety, maintenance and security considerations.
- **IEEE 1561**
  - Guide for Optimizing the Performance and Life of Lead-Acid Batteries in Remote Hybrid Power Systems.
    - **Description:** IEEE 1561 is a guide that provides recommendations for improving the performance and lifespan of lead-acid batteries used in

remote hybrid power systems, which combine renewable and traditional energy sources.

- **IEEE 1526-2020**

- IEEE Recommended Practice for Testing the Performance of Stand-Alone Photovoltaic Systems.

- **Description:** IEEE 1526-2020 is a recommended practice for testing the performance of stand-alone photovoltaic systems, providing guidance on testing methods and procedures to ensure optimal system performance and reliability.

- **IEEE 1561-2021**

- IEEE Guide for Optimizing the Performance and Life of Lead-Acid Batteries in Remote Hybrid Power Systems.

- **Description:** IEEE 1561-2021 is a guide for optimizing the performance and life of lead-acid batteries in remote hybrid power systems. The standard provides guidance on the selection, installation, operation, and maintenance of lead-acid batteries used in remote power systems that combine renewable energy sources with traditional power sources, such as diesel generators. The guide covers topics such as battery sizing, charging and discharging strategies, temperature management, and maintenance practices. It is intended to help system designers, operators, and maintenance personnel to improve the performance and longevity of lead-acid batteries used in remote hybrid power systems.

- **IEEE 1661**

- This guide is specifically prepared for a PV/engine generator hybrid power system, but may also be applicable to all hybrid power systems where there is at least one renewable power source.

- **Description:** This document provides a uniform standard for the interconnection and interoperability of distributed energy resources with electric power systems. It provides requirements relevant to the interconnection and interoperability performance, operation and testing, and, to safety, maintenance and security considerations.

### **1.3 Systematic Overview / Summary of the proposed project**

Today, using hybrid energy sources is a standard practice. Our project's goal is to split loads among hybrid energy sources for domestic use. In the majority of cases, domestic applications use either conventional or renewable energy sources. However, in order to run household loads from both sources concurrently and reduce our reliance on fossil fuel, we try to do so. Here, the automatic transfer switch (ATS) will regulate the hybrid energy sources based on the load demand, the accessibility of the energy sources, and the state of charge (SOC) of the storage system. We make use of Proteus to create ATS. This system guarantees continuous power supply to household loads by minimum use of grid energy which is cost efficient and enhances reliability of our system.

### **1.4 Conclusion:**

In conclusion, the project's goals are to develop a solar and grid-powered hybrid energy system that is affordable and sustainable for Bangladeshi families. As the world experiences a fossil fuel crisis as a result of overuse in transportation and power generation, the use of renewable energy sources is becoming more and more crucial. Due to urbanization, automation, and industrialization, Bangladesh's energy needs are rising. This project can assist meet those needs while lowering the nation's reliance on fossil fuels and advancing sustainable energy management practices.

To assure continuous power supply to residential loads, the project includes an automated load-sharing system, automated battery charging, and an automated transfer switch, which can assist lower consumer electricity bills. The method uses two batteries that may be charged alternately to ensure a consistent power source and a longer battery life, in addition to addressing the issues of battery lifespan and charging pace.

## Chapter 2: Project Design Approach [CO5, CO6]

### 2.1 Introduction

In this chapter, we select three different designs to ensure load sharing using hybrid energy sources. We set different controlling systems to ensure uninterrupted power supply and simulate them using MATLAB Simulink. Then we analyze all of them based on different parameters for example charging and discharging time of battery, supply voltage and current level across loads, Durability of battery, maintenance, efficiency.

### 2.2 Identify multiple design approach

We design three different approaches for load sharing between hybrid sources in household applications. They are

1. Load shared by solar charged battery and main grid
2. Load shared by solar, grid and backup storage
3. Load Shared for island by fuel cell & wind turbine

### 2.3 Describe multiple design approach

#### 2.3.1 Load shared by solar charged battery and main grid

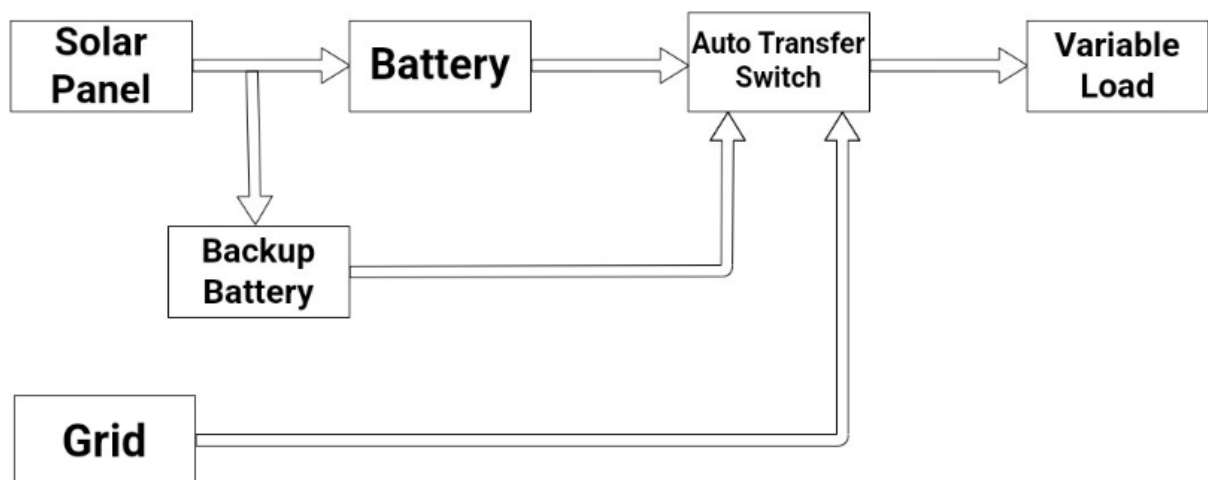


Figure 1: Block diagram of Design 01

## **Controller mechanism:**

### **Scenario 1: Load demand is less and solar is available**

- One battery will be charged by solar and other will be discharged to the small loads.
- If battery 1 SOC drops below 30% it will stop discharging and start charging from solar. Meanwhile battery 2 will now discharge.

### **Scenario 2: Load demand is less and solar power is unavailable**

- If both battery SOC drops below 30%, loads will be connected to the grid.

### **Scenario 3: Load demand is more and solar is available**

- Large loads will be powered from battery 2.
- Small loads will run as before.

### **Scenario 3: Load demand is more and solar is unavailable**

- all loads will be powered up by grid.

### **Scenario 3: Solar and Grid power is unavailable**

- Loads will be powered from the battery until grid power becomes available again. If blackout lasts long enough to cause both batteries to drain out, then loads can no longer be powered by the system.

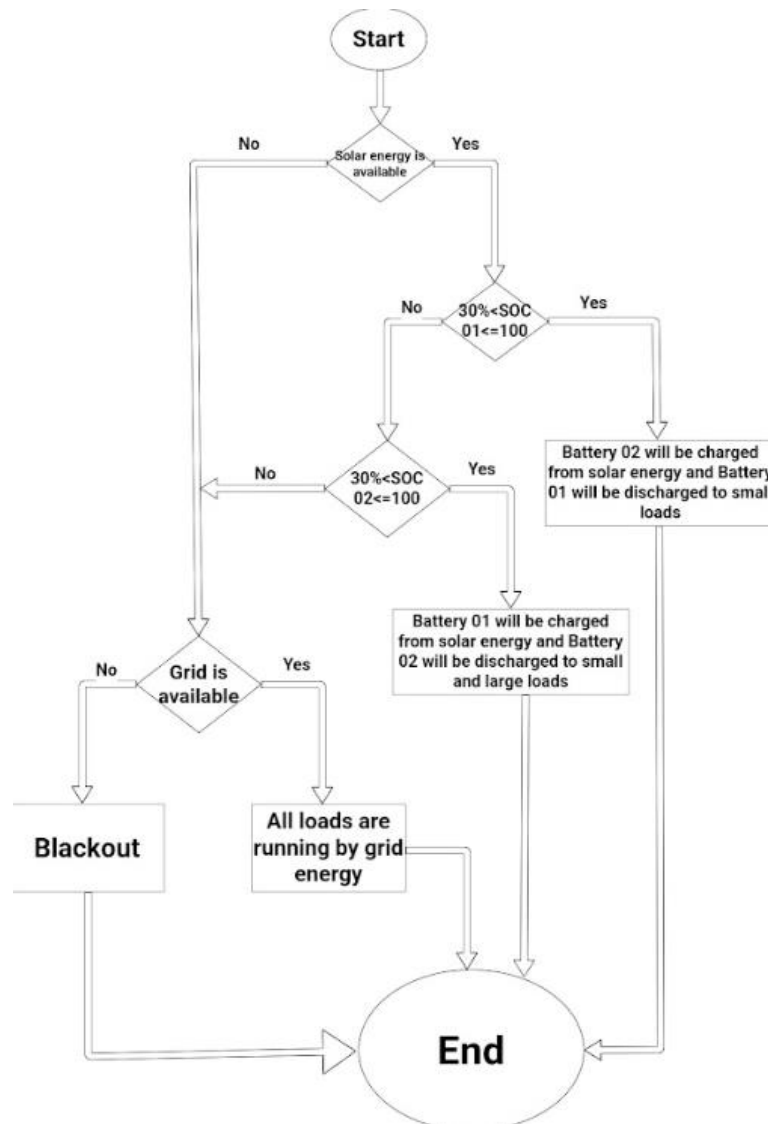
## **Explanation:**

In this design, loads will be shared by grid and solar panels. Two batteries are used as charge storage. At initial state both of the batteries will be charged from solar panels. When they are fully charged, then they are ready for discharging. Here we divide all loads under two categories; small loads and large loads. Small loads are connected to both of the batteries and grid. On the other hand, large loads are connected to battery 2 and grid. The whole system will be controlled by ATS. We use in total 5 relays under ATS to control all the loads.

Firstly, all small loads are connected to battery 1 and large loads with battery 2. When small loads are active, then if a certain battery SOC drops below 30%, it will disconnect from the loads and start charging from the solar panels. Meanwhile, other batteries will now be discharging to the load. Thus, both batteries will take turns and power the loads. However, if both battery SOC drops below 30%, batteries will cease to supply power to the loads. Instead, loads will be connected to the grid. As the second battery is connected to load, so when load demand is increasing for large loads, then battery 2 will be discharging. Again, if the SOC of the 2<sup>nd</sup> battery is less than 30% then large loads will be connected to the grid.

Solar panels are connected to a DC-DC converter which will provide a stable output to match the battery charging voltage. The switching action between battery, loads and grid will be controlled by transfer switches. Batteries are connected to loads through an inverter which will convert DC voltage to AC output. The batteries in this design work as medium between solar panels and load. Instead of directly supplying solar power to the loads, batteries function as charge storage and store solar power so that it can be utilized at night. After depletion of battery storage, the system switches to grid power and thus loads are shared between solar power and grid. The availability of solar power depends on the weather as well as sizing of the panels. Since, there are two batteries in the system therefore solar power can be utilized more efficiently. Also, the system can provide power for longer in case any black-out occurs. The switching action between solar power and grid is controlled by a control algorithm that takes battery SOC, available source and load demand as input and based on the inputs, it controls charging, discharging and switching between sources.

**Functionality of auto transfer switch:**



**Figure 2:** Functionality of ATS system

### Constraints:

The use of two batteries will cause more installation cost and maintenance as battery conditions need to be checked regularly.

### 2.3.2 Load shared by solar, grid and backup storage

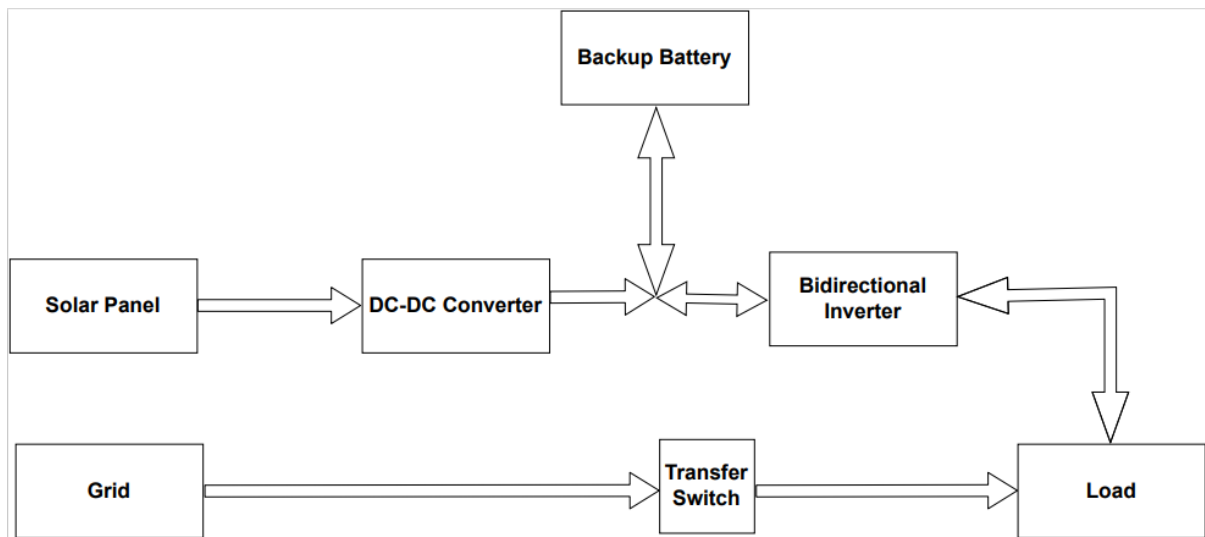


Figure 3: Block diagram of Design 02

### Controller mechanism:

#### Scenario 1: Grid and solar power are available

- PV will be prioritized
- solar energy is supplied to loads
- Battery will be charged

#### Scenario power 2: Grid power is available, solar unavailable, SOC>30%

- Battery will be prioritized
- Battery will support the loads
- Battery will be discharged

#### Scenario power 3: Grid power is available, solar unavailable, SOC<30%

- Grid will be prioritized
- Battery will be charged



In this way, we are ensuring dynamic load sharing using main grid, solar panel and backup storage and controlling them depending on their availability and SOC of the battery.

### **Explanation**

In this design approach, load will be shared by solar, grid and backup storage(battery). As solar panels are charged by solar energy at daylight, so we will get dc voltage and current from solar panels. In order to increase voltage level, we use a dc-dc converter (boost converter). Now by converting this dc energy to ac, load can be shared by solar energy. Normally, load demand varies time to time. It's more at peak hour and less at off hour. Therefore, for the optimum use of solar energy, we can store it in a battery. So that the excess solar energy will be stored in backup battery. At night, when solar energy is not available, then the backup battery will be discharged to load. As it is a dc source, we convert it into ac before connecting to loads. In this way load can be shared using backup battery. Main grid will be connected to loads only when solar energy is not available and State of charge of the battery is nominal (30%). For example, it's raining all day long, atmospheric irradiance and temperature is less than as usual day. That time along with solar energy, backup storage energy is negligible. To avoid power cut at that situation, grid will be connected to loads. In short, grid energy is used here only when neither solar energy nor backup storage is available. So, dependency on grid which is a fossil-fuel based source, is reduced. Again, as dependency on grid energy is reduced, so electricity bill will also be reduced. In this way, load will be shared by solar, grid and backup storage. And a transfer switch is controlling all the hybrid sources which is mentioned earlier.

### **Constraints:**

The system is not reliable in extreme weather conditions when solar panels cease to function for a long time and the grid becomes unavailable at the same time. As a result, the system can suffer from black-outs.

### 2.3.3 Load shared for island by fuel cell & wind turbine

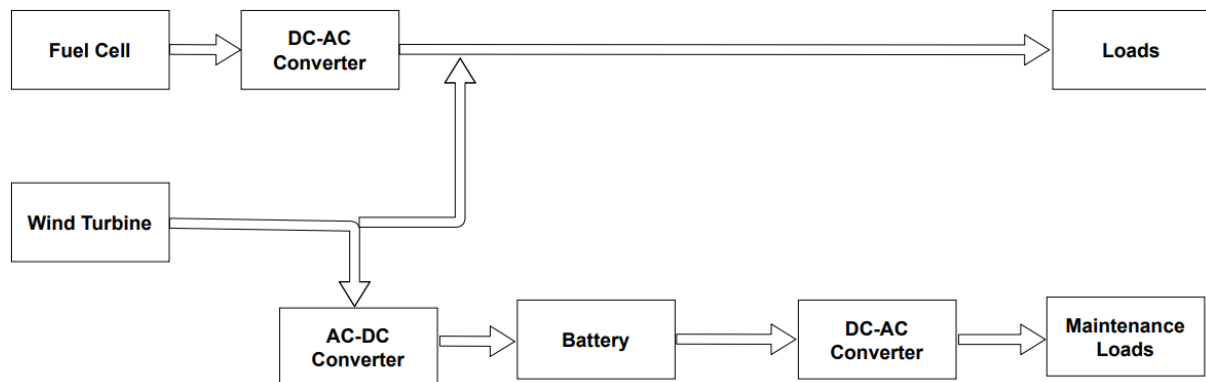


Figure 4: Block diagram of design 3

#### Controller mechanism:

##### Scenario 1: Peak hour

- loads are shared by fuel cell and wind turbine
- battery will be discharged when necessary
- battery will support the maintenance loads

##### Scenario 2: Off hour

- loads are shared by fuel cell and wind turbine
- Battery will be charged by excess wind energy and discharged when necessary.
- Battery will support the maintenance loads

In this way, we are ensuring dynamic load sharing using hydrogen fuel cell, battery and wind turbine and controlling them depending on load demand in different time of a day.

#### Explanation:

This design is applicable for those areas or islands where there is no grid connection. They can use hydrogen fuel cell as their main power source and any kind of renewable energy source as a backup power source for load sharing. For example, we use wind turbine as our green energy source. According to load demand we can divide a day into two different hours-Peak hours & off hours. At peak hours, all loads are supported by wind energy and hydrogen fuel cell. So that loads will be shared by fuel cell and wind turbine at the same time which ensures dynamic load sharing in hybrid systems. But at off hour, demand for loads is comparatively

less than pick hour. As a result, after load sharing, we will get a large amount of wind energy and we can easily store that excess energy. So, for the optimization of renewable energy, we are charging a battery with excess energy. This battery will support the maintenance load on demand. As maintenance loads are powered by battery and large loads are powered by wind turbine and fuel cell combinedly, so dependency on hydrogen fuel cell is reduced which also reduces monthly cost for fuel cell. In this way, we can apply load sharing concept between hybrid sources for island.

**Constraints:**

- very small amount of fuel cell energy share load with a large amount of wind turbine energy.
- Cost of a wind turbine is comparatively higher than solar panels. Again, hydrogen fuel cell is costlier than grid energy. So, this system is not cost efficient for the rural people who are deprived of grid energy.

**Design Comparison**

TABLE 5: Design comparison

| Parameter     | Design approach 1<br>(Load shared by solar charged battery and main grid) | Design approach 2<br>(Load shared by solar, grid and backup storage) | Design approach 3 (Load Shared for island by fuel cell & wind turbine)  |
|---------------|---|--|---|
| Load -sharing | loads' power will be supplied from grid and solar charged battery.        | Loads' will receive power from grid, solar power & backup storage.   | All loads' power will be supplied from hydrogen fuel cell and wind energy. Maintenance loads will be supplied from wind energy. |

|  |  |   |   |
|--|--|---|---|
| Battery  | 2 solar charged batteries are used in this system. They will be charged and discharged according to their SOC. When 1 <sup>st</sup> battery is charged from PV, then 2 <sup>nd</sup> battery is discharged to loads or vice versa. | Battery works as a back-up power source for loads. When solar energy is insufficient, then the loads will receive stored energy from battery. | Battery is used to store excess wind turbine energy. When there is any need of maintenance loads, then battery will support these loads.  |
| Controlling system                             | Controlling system depends on state of charge of the battery   | Controlling system depends on availability of renewable source & state of charge of the battery.  | Controlling system depends on availability of wind turbine energy and fuel cell.  |
| Durability of battery, maintenance, efficiency | Since the entire power for all loads will be supplied by the battery hence, battery durability is comparatively lower. As a result, system maintenance cost will increase which reduces system efficiency.                         | Since, battery works as a back-up power source therefore durability will be higher than design approach 1.                                    | Since the entire power for all loads will be supplied by hydrogen fuel cell and wind turbine energy and battery supply energy only to the maintenance loads, so durability will be higher than design approach 2. |

## 2.4 Analysis of multiple design approach

### 2.4.1 Load shared by solar charged battery and main grid

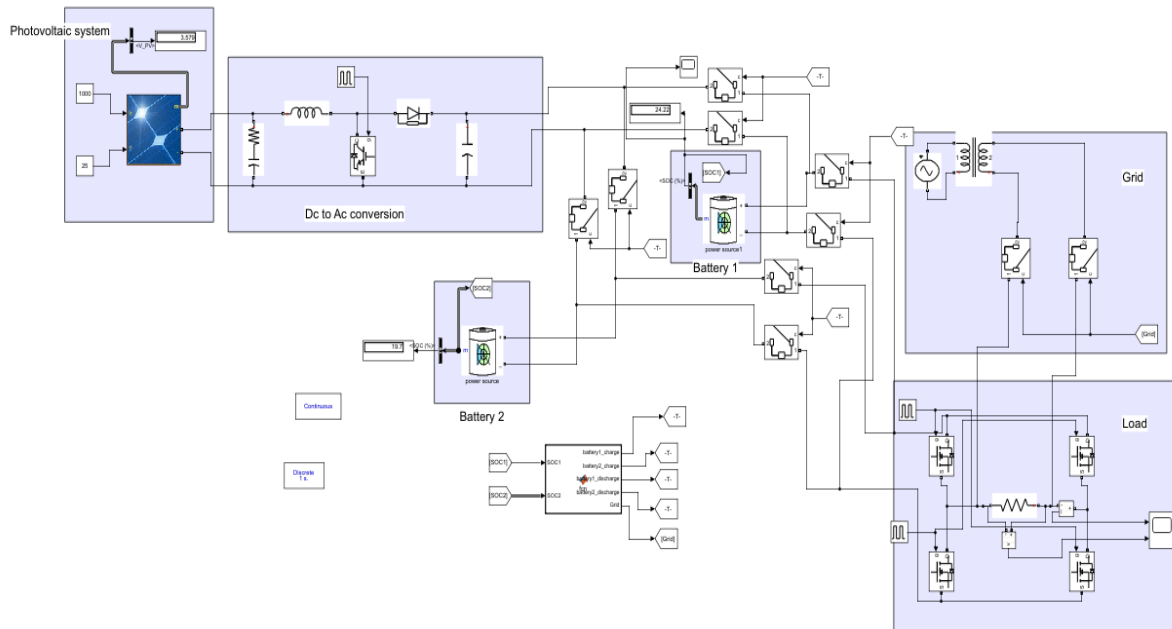


Figure 5: Simulation of design 01

Name: LONGi Solar LR6-60BK

**Properties**

Name: **LONGi Solar LR6-60BK**

Abbreviation: **LR6-60BK**

Panel Type: **Flat plate**

Rated Capacity (kW): **0.295**

Temperature Coefficient: **-0.410**

Operating Temperature (°C): **47**

Efficiency (%): **18**

Manufacturer: **LONGi Solar Technology Co., Ltd.**

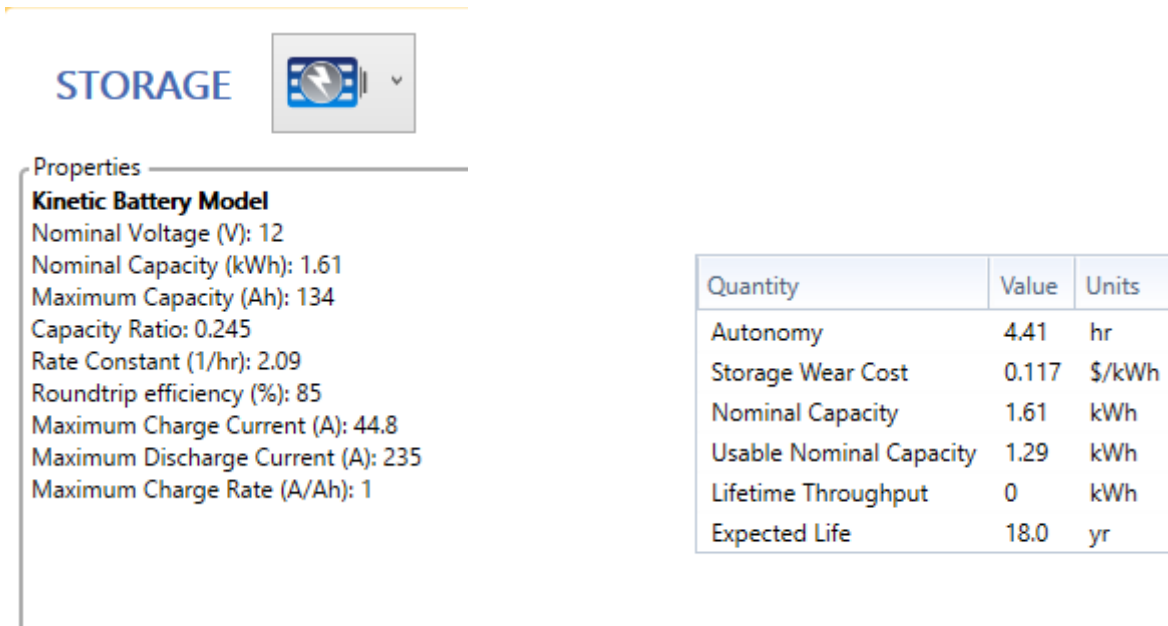
<http://www.lerri.com/>

Notes:

**Mono. 18.2 kg. Footprint - 1.63515 m2.**

| Quantity         | Value | Units  |
|------------------|-------|--------|
| Rated Capacity   | 1.30  | kW     |
| Mean Output      | 0.200 | kW     |
| Mean Output      | 4.80  | kWh/d  |
| Capacity Factor  | 15.4  | %      |
| Total Production | 1,751 | kWh/yr |

Figure 6: Specifications of solar panels



**Figure 7:** Specifications of Battery

| Quantity        | Inverter | Rectifier | Units |
|-----------------|----------|-----------|-------|
| Capacity        | 0.384    | 0.384     | kW    |
| Mean Output     | 0.131    | 0         | kW    |
| Minimum Output  | 0        | 0         | kW    |
| Maximum Output  | 0.384    | 0         | kW    |
| Capacity Factor | 34.2     | 0         | %     |

**Figure 8:** Specifications of Converter

For daily 7kWh load demand we have designed our system in HOMER Pro. After simulation, we have obtained all the required specifications which are shown below:

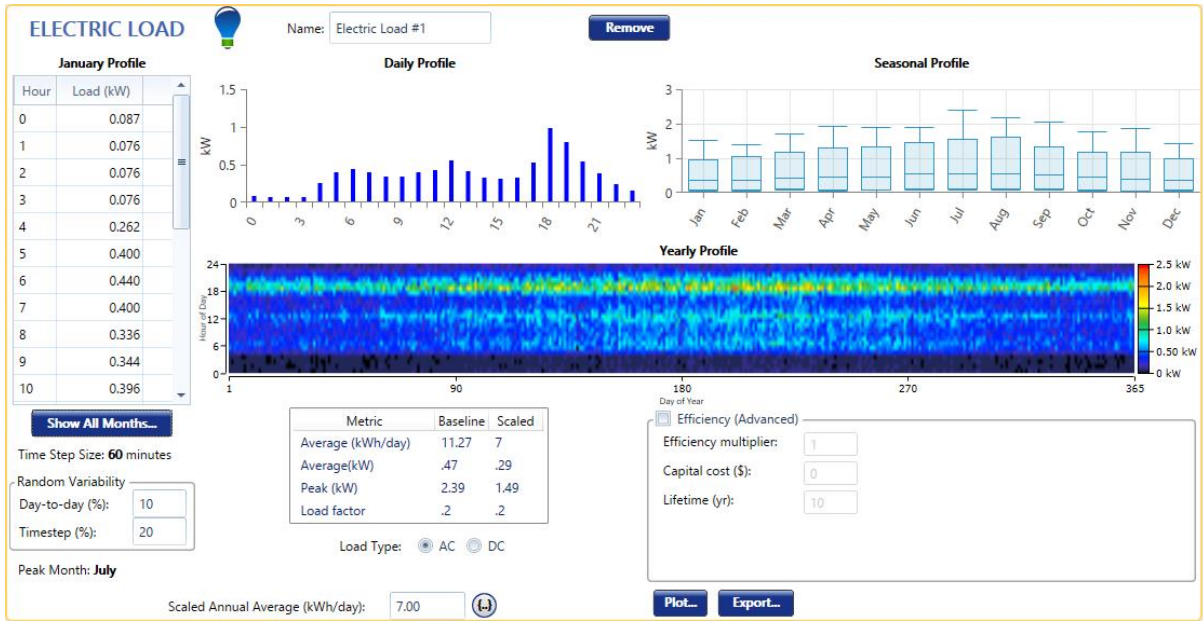


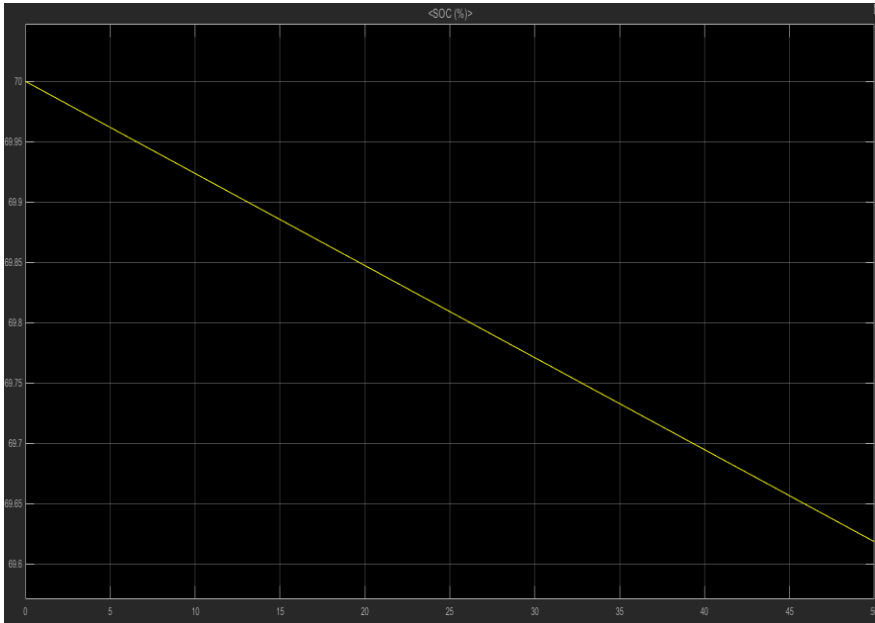
Figure 9: Electric Load from HOMER Pro

| Hour | January | February | March | April | May   | June  | July  | August | September | October | November | December |
|------|---------|----------|-------|-------|-------|-------|-------|--------|-----------|---------|----------|----------|
| 0    | 0.087   | 0.090    | 0.098 | 0.109 | 0.120 | 0.128 | 0.131 | 0.128  | 0.120     | 0.109   | 0.098    | 0.090    |
| 1    | 0.076   | 0.079    | 0.085 | 0.095 | 0.105 | 0.111 | 0.114 | 0.111  | 0.105     | 0.095   | 0.085    | 0.079    |
| 2    | 0.076   | 0.079    | 0.085 | 0.095 | 0.105 | 0.111 | 0.114 | 0.111  | 0.105     | 0.095   | 0.085    | 0.079    |
| 3    | 0.076   | 0.079    | 0.085 | 0.095 | 0.105 | 0.111 | 0.114 | 0.111  | 0.105     | 0.095   | 0.085    | 0.079    |
| 4    | 0.262   | 0.271    | 0.294 | 0.327 | 0.360 | 0.383 | 0.392 | 0.383  | 0.360     | 0.327   | 0.294    | 0.271    |
| 5    | 0.400   | 0.415    | 0.450 | 0.500 | 0.550 | 0.585 | 0.600 | 0.585  | 0.550     | 0.500   | 0.450    | 0.415    |
| 6    | 0.440   | 0.457    | 0.495 | 0.550 | 0.605 | 0.644 | 0.660 | 0.644  | 0.605     | 0.550   | 0.495    | 0.457    |
| 7    | 0.400   | 0.415    | 0.450 | 0.500 | 0.550 | 0.585 | 0.600 | 0.585  | 0.550     | 0.500   | 0.450    | 0.415    |
| 8    | 0.336   | 0.349    | 0.378 | 0.420 | 0.462 | 0.491 | 0.504 | 0.491  | 0.462     | 0.420   | 0.378    | 0.349    |
| 9    | 0.344   | 0.357    | 0.387 | 0.430 | 0.473 | 0.503 | 0.516 | 0.503  | 0.473     | 0.430   | 0.387    | 0.357    |
| 10   | 0.396   | 0.411    | 0.446 | 0.495 | 0.545 | 0.579 | 0.594 | 0.579  | 0.545     | 0.495   | 0.446    | 0.411    |
| 11   | 0.426   | 0.442    | 0.480 | 0.533 | 0.586 | 0.624 | 0.640 | 0.624  | 0.586     | 0.533   | 0.480    | 0.442    |
| 12   | 0.553   | 0.574    | 0.622 | 0.691 | 0.760 | 0.808 | 0.829 | 0.808  | 0.760     | 0.691   | 0.622    | 0.574    |
| 13   | 0.415   | 0.431    | 0.467 | 0.519 | 0.571 | 0.607 | 0.623 | 0.607  | 0.571     | 0.519   | 0.467    | 0.431    |
| 14   | 0.334   | 0.347    | 0.376 | 0.418 | 0.460 | 0.489 | 0.502 | 0.489  | 0.460     | 0.418   | 0.376    | 0.347    |
| 15   | 0.318   | 0.330    | 0.357 | 0.397 | 0.437 | 0.464 | 0.476 | 0.464  | 0.437     | 0.397   | 0.357    | 0.330    |
| 16   | 0.327   | 0.339    | 0.368 | 0.409 | 0.450 | 0.479 | 0.491 | 0.479  | 0.450     | 0.409   | 0.368    | 0.339    |
| 17   | 0.526   | 0.546    | 0.592 | 0.658 | 0.724 | 0.770 | 0.790 | 0.770  | 0.724     | 0.658   | 0.592    | 0.546    |
| 18   | 0.985   | 1.022    | 1.108 | 1.231 | 1.354 | 1.440 | 1.477 | 1.440  | 1.354     | 1.231   | 1.108    | 1.022    |
| 19   | 0.802   | 0.832    | 0.903 | 1.003 | 1.103 | 1.174 | 1.204 | 1.174  | 1.103     | 1.003   | 0.903    | 0.832    |
| 20   | 0.541   | 0.561    | 0.608 | 0.676 | 0.744 | 0.791 | 0.811 | 0.791  | 0.744     | 0.676   | 0.608    | 0.561    |
| 21   | 0.384   | 0.398    | 0.432 | 0.480 | 0.528 | 0.562 | 0.576 | 0.562  | 0.528     | 0.480   | 0.432    | 0.398    |
| 22   | 0.240   | 0.249    | 0.270 | 0.300 | 0.330 | 0.351 | 0.360 | 0.351  | 0.330     | 0.300   | 0.270    | 0.249    |
| 23   | 0.163   | 0.169    | 0.184 | 0.204 | 0.224 | 0.239 | 0.245 | 0.239  | 0.224     | 0.204   | 0.184    | 0.169    |

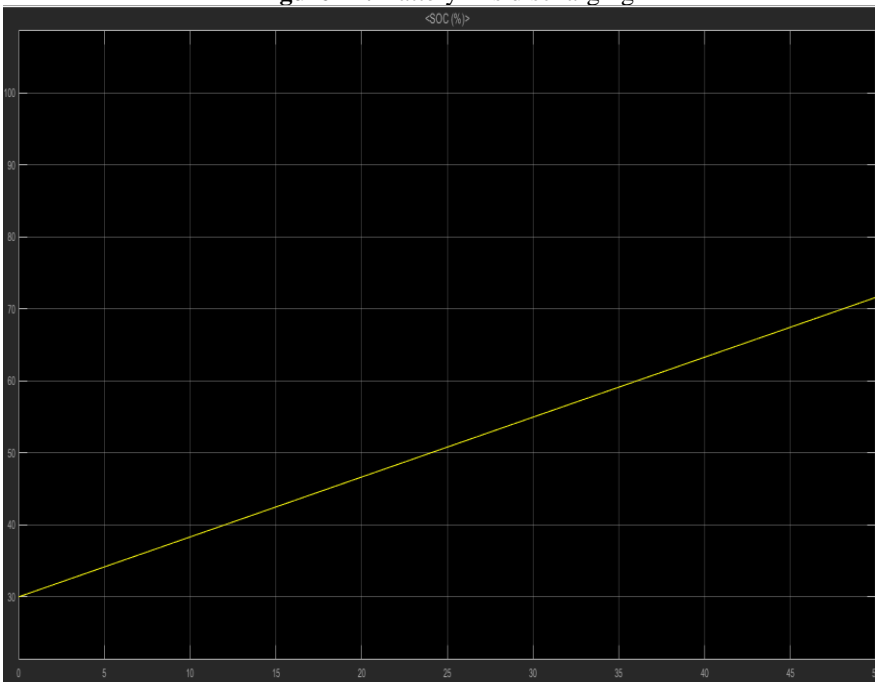
Figure 10: Load profile from HOMER Pro for a year

**Scenario 1:**

Battery 1 SOC more than 30 percent, Battery 2 SOC less than 30 percent. So, battery 1 will be discharged to load and battery 2 will be charged from the PV panel. We will get certain level of Current & voltage across load from battery 1.

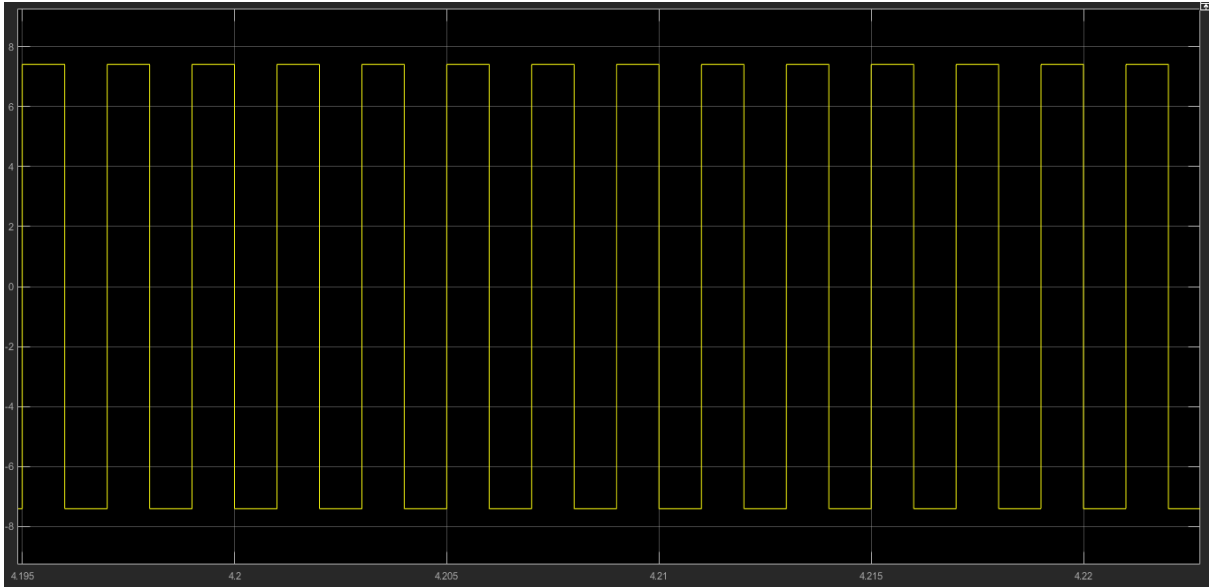


**Figure 11: Battery 1 is discharging**



**Figure 12: Battery 2 is charging**





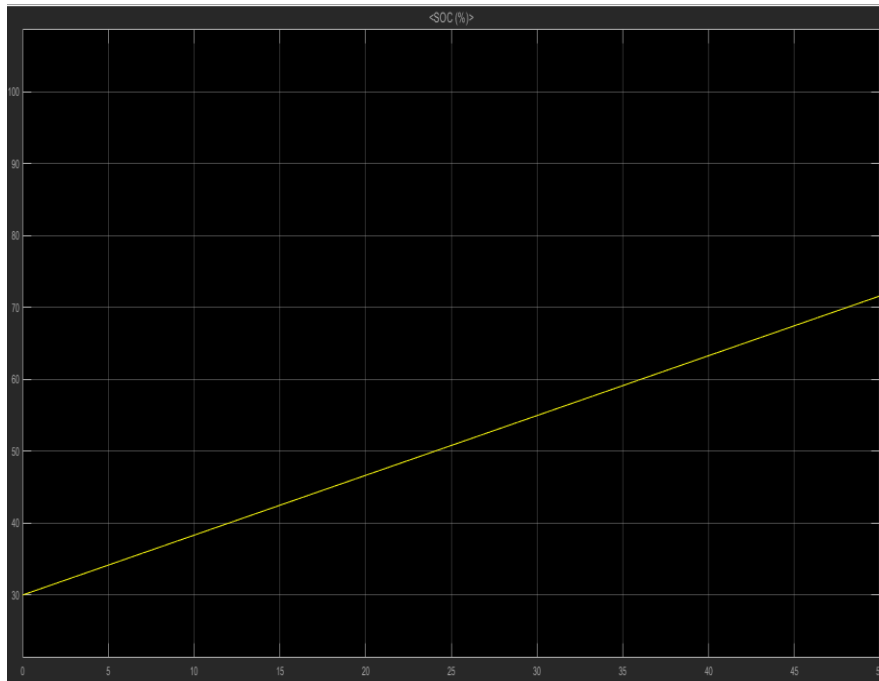
**Figure 13:** Voltage vs Time across load

**Scenario 2:**

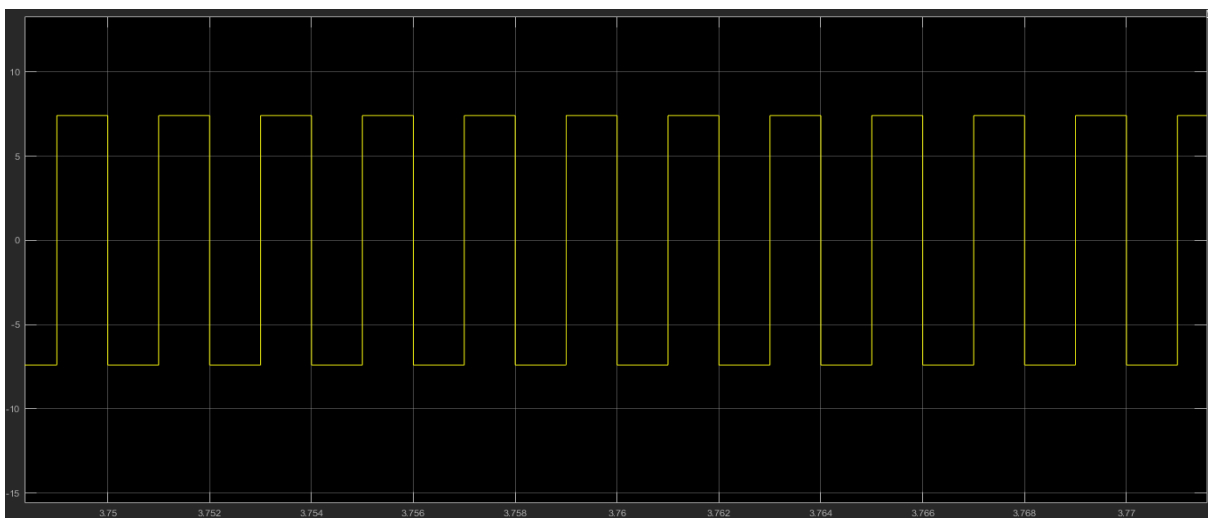
Battery 2 SOC more than 30 percent, Battery 1 SOC less than 30 percent. So, battery 2 will be discharged to load and battery 1 will be charged from the PV panel. We will get a certain level of Current & voltage across load from battery 2.



**Figure 14:** Battery 2 is discharging



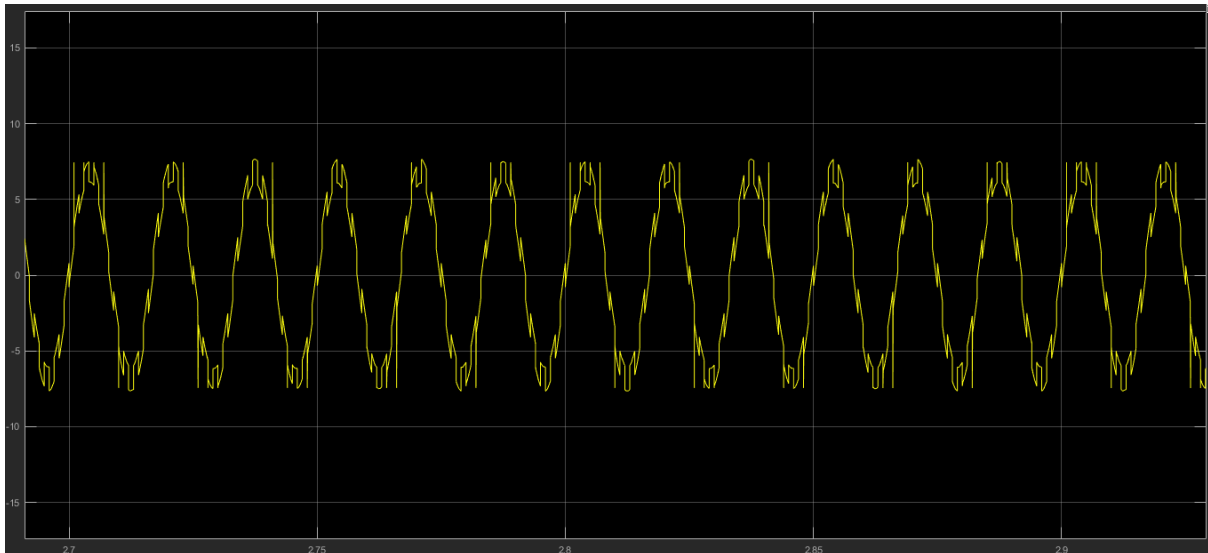
**Figure 15:** Battery 2 is charging



**Figure 16:** Voltage vs Time across load

**Scenario 3:**

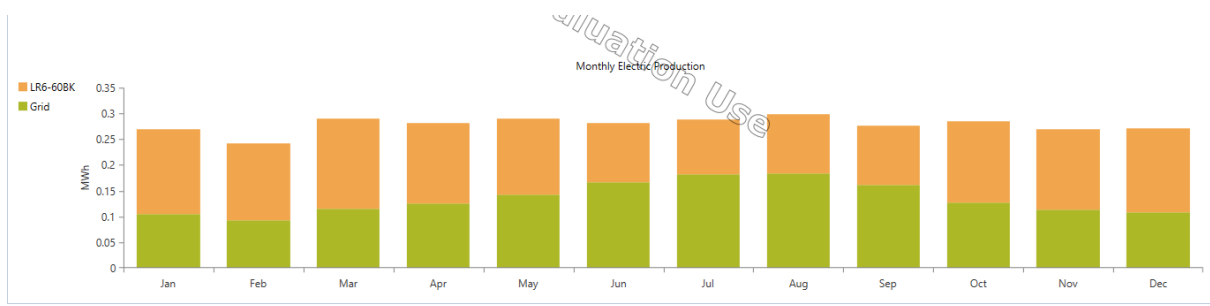
Both the batteries have SOC less than 30 percent. At this moment, neither battery 1 nor battery 2 will support the load. Here, the main grid is connected to the load. So, we will get certain level of Current & voltage across load from grid.



**Figure 17:** Voltage vs Time across load

**Load sharing:**

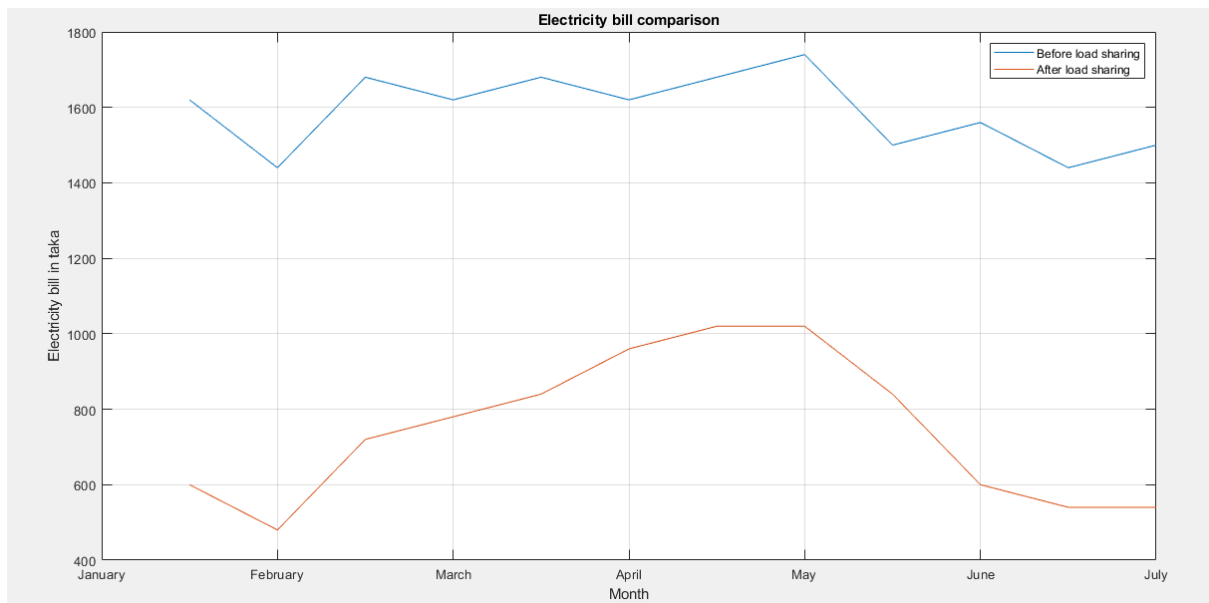
We have designed our system for 7kWh daily load demand and run the simulation in Homer pro to find the appropriate sizing of solar panels, battery and inverter. For our system, the solar panels capacity has turned out to be around 1.30 kW. The load sharing mainly depends on the availability of solar power throughout the year. As solar irradiation depends on geographic location, we have selected our location at Dhaka. Based on the irradiation data, Homer Pro predicted the availability of solar energy and the subsequent load sharing pattern throughout the year.



**Figure 18:** Load sharing between solar and grid

From the figure, we can see that the usage of grid energy was high during the summer. The usage for grid power was higher than that of solar power during June-September. For the rest of the months, solar power had a significantly higher contribution in load sharing.

## Electricity bill comparison:

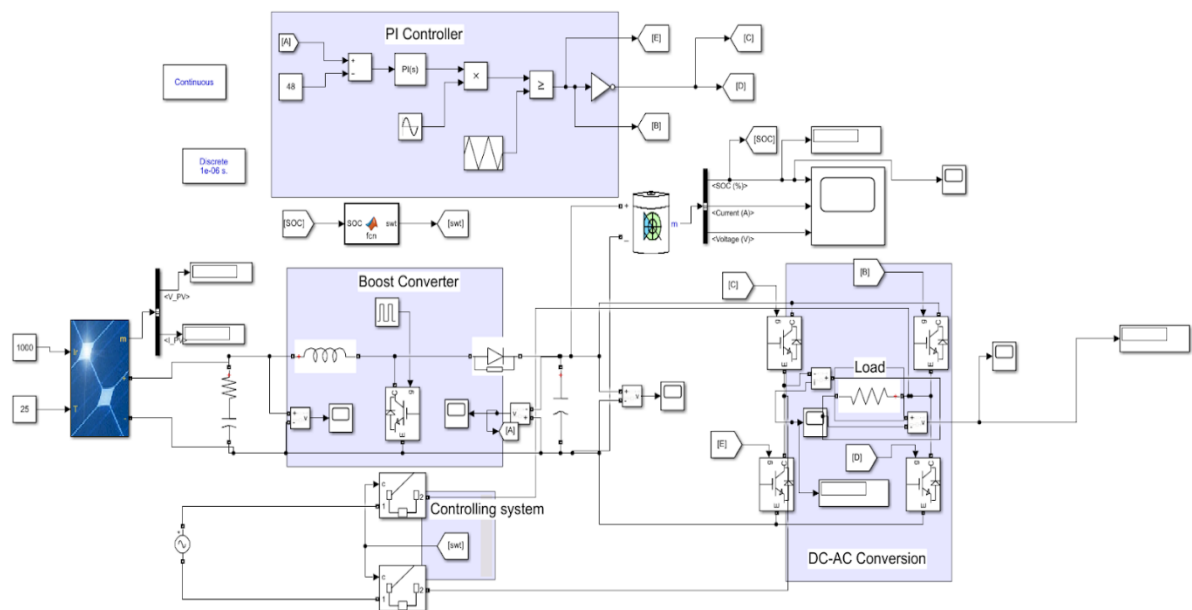


**Figure 19:** Electricity bill comparison

In this figure, the impact of load sharing on reducing electricity bills is quite evident as the bill for most of the months remains within 1000 taka after load sharing is implemented.

The reduced electricity bill indicates less dependency on grid power which is mainly produced in fossil fuel run power plants. Thus, we can infer that household load sharing can have a massive impact on reducing our dependence on fossil fuels.

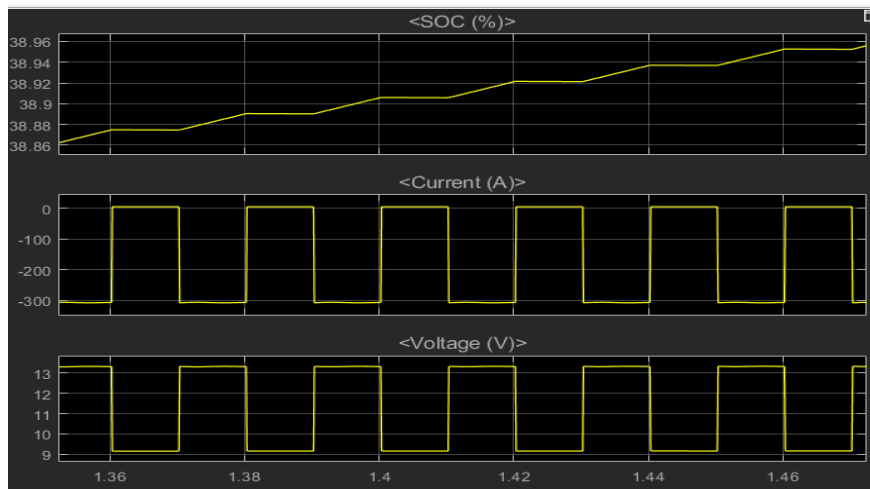
### 2.4.2 Load shared by solar, grid and backup storage



**Figure 20:** Circuit diagram of load shared by solar, grid and backup storage

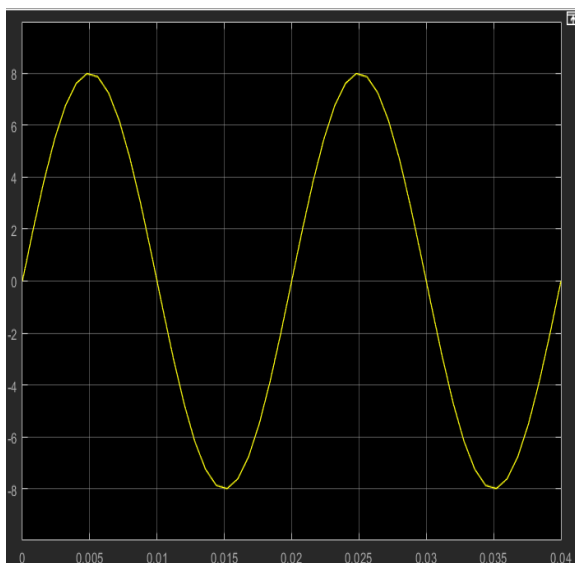
We use a switch to control the overall load sharing system. This switch is expressed here as 'swt'. Initially, this switch is off. So, no power can pass to load from the grid. If SOC is less than or equal to 30%, then switch will be on to power up load from the main grid. In this way, we are ensuring the Controlling mechanism of the system.

In this design we get results for three different conditions. In the first condition, the solar panel will be charged from sun energy and excess energy will be stored in the battery. As we set the initial state of the battery is 30%, so SOC will be increased from its initial state which ensures automated battery charging. In this state load will be shared by the PV panel. So, we get a fixed amount of current and voltage across load.

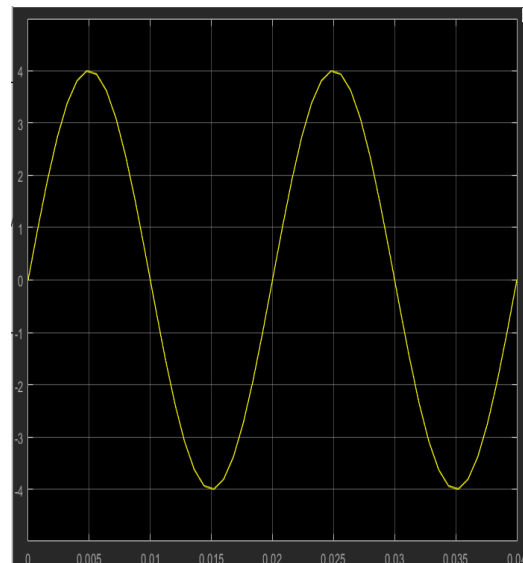


**Figure 21:** SOC, Current(A), voltage(v) vs time(s) graph of battery while charging

Here current level of the battery is negative because the battery is charging from another source (PV panel).

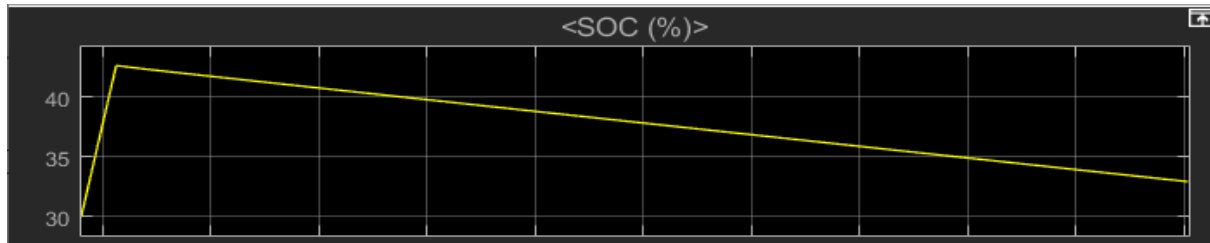


**Figure 22:** Voltage(V) vs time(s)graph across load



**Figure 23:** Current(A) vs time(s)graph through load

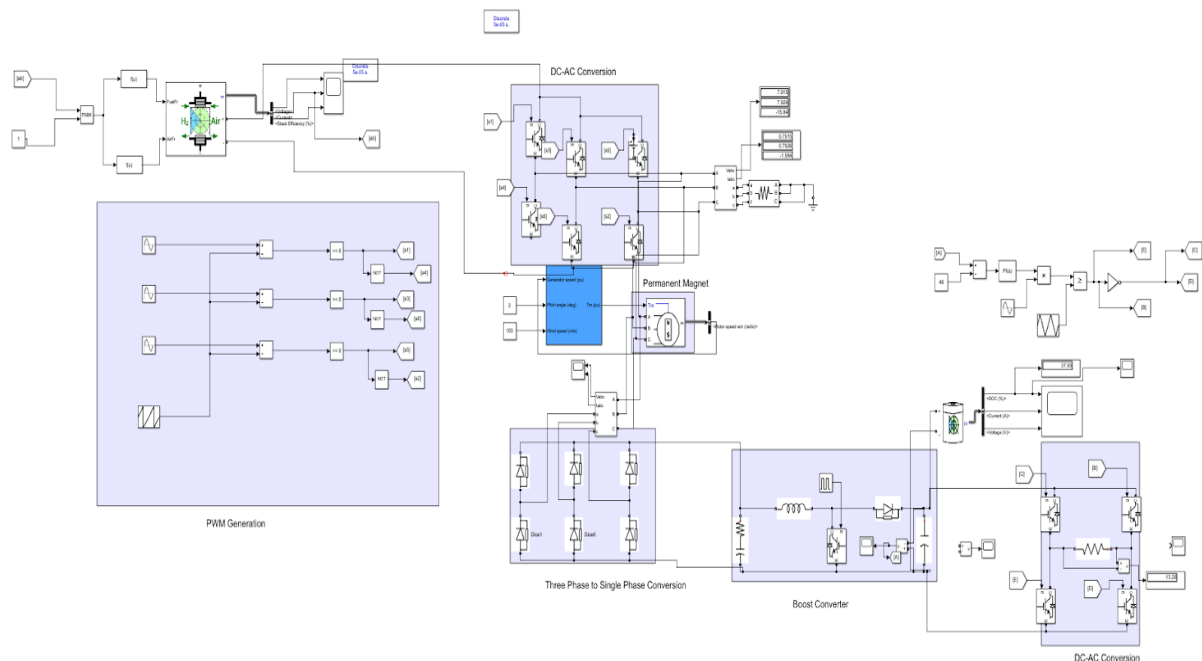
Second condition is applicable when sun is not available and SOC of the battery will be more than 30%. Then the battery will be discharged and the load will be shared by a battery which is previously charged by solar energy. This makes us sure about utilization of solar energy. As a consequence, SOC will be decreased. We will get the same level of current and voltage across load like the 1<sup>st</sup> condition.



**Figure 24:** SOC vs time(s) graph while discharging

3<sup>rd</sup> condition is designed for extreme situation when neither PV panel nor backup storage system is able to supply power to load. Then, load will be shared by main grid. Here, we will get again same amount of current and voltage across the same load. In this way, we are controlling automated load sharing for different conditions between hybrid sources.

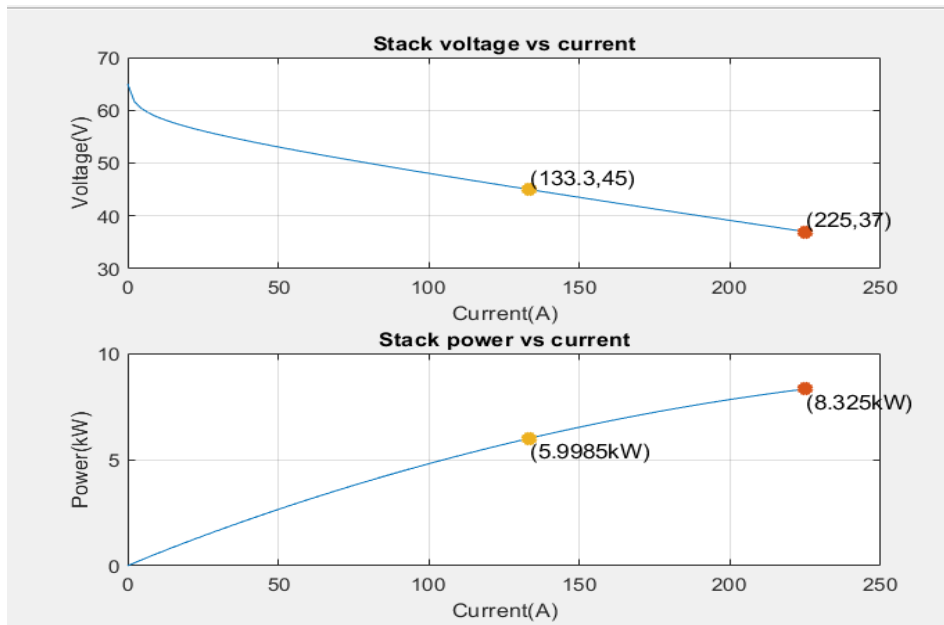
### 2.4.3 Load shared for island by fuel cell & wind- turbine:



**Figure 25:** Circuit diagram of load shared for island by fuel cell & wind turbine.

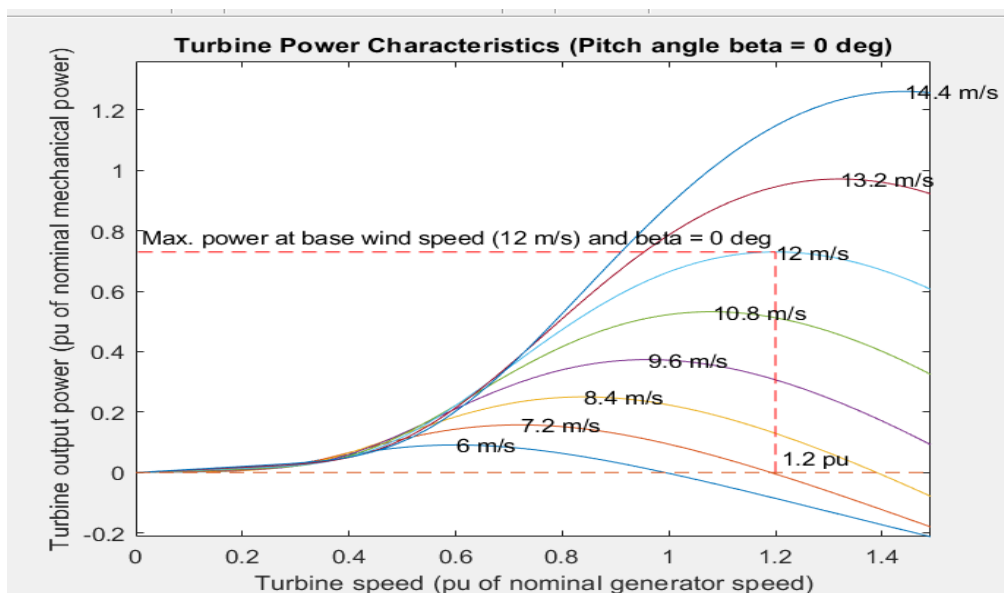
In this design we use a hydrogen fuel cell instead of grid energy. This fuel cell has its own voltage -current (VI) and power current (PI) characteristics according to its nominal and

maximum operating point, efficiency, number of cells and others. Here, the nominal operating VI point is (133.3,45) & maximum operating VI point is (225,37). Based on this value we get a VI & PI graph from Simulink.



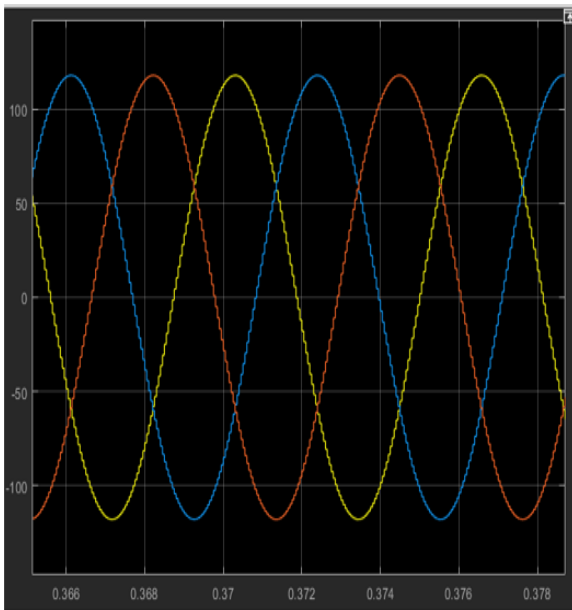
**Figure 26:** VI and PI characteristics of Hydrogen Fuel cell

Again, we use wind turbines as renewable energy sources. Its base wind speed is 12m/s and base rotational speed (pu of nominal mechanical power) is 1.2. According to this, we get output power vs turbine speed from Simulink.

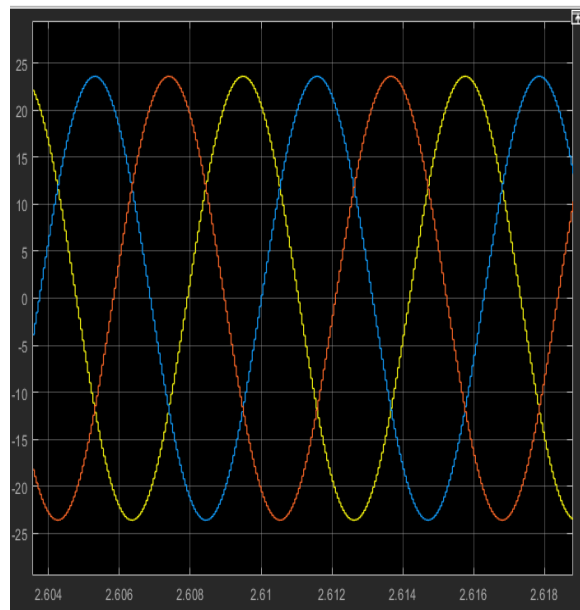


**Figure 27:** Turbine power characteristics of Wind Turbine

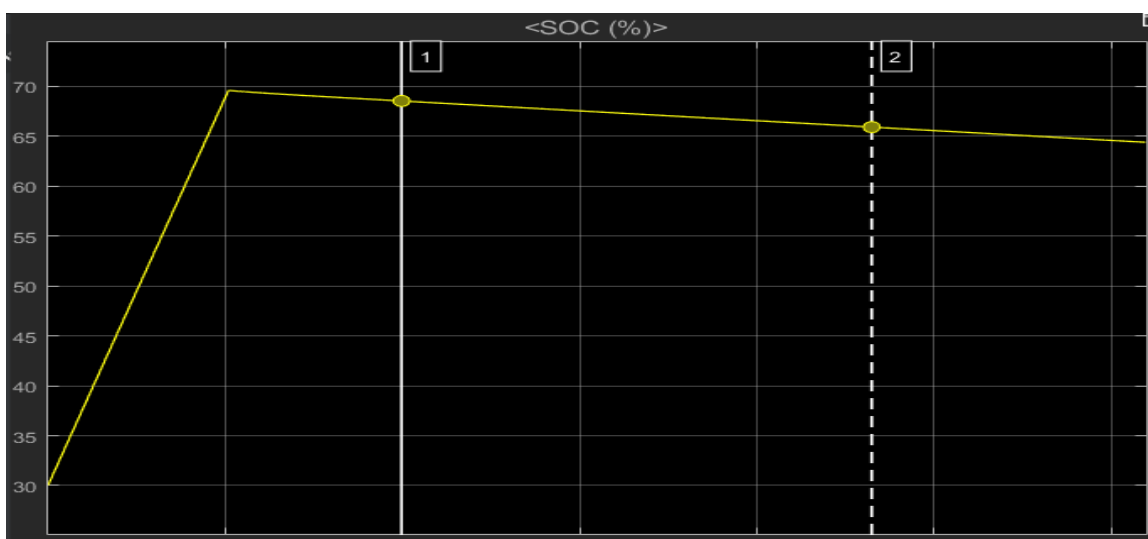
In this design, hydrogen fuel and wind turbine energy are combinedly shared loads. So, the current and voltage we will get across loads, is also supplied by both of the mentioned sources which ensures automated load sharing. We may get excess wind energy. We can charge a battery using this excess wind energy as automated battery charging. So, the SOC of the battery will be increased that time. There are also some maintenance loads under a house or island which are considered here as small loads. These kinds of small loads will be shared by the battery. As a result, we can utilize the wind energy most. Battery will be discharged at that time and the SOC of the battery will be reduced. In such a way, we are controlling automated load sharing among hydrogen fuel cell, wind turbines & batteries.



**Figure 28:** Voltage(v) vs time(s) graph across load

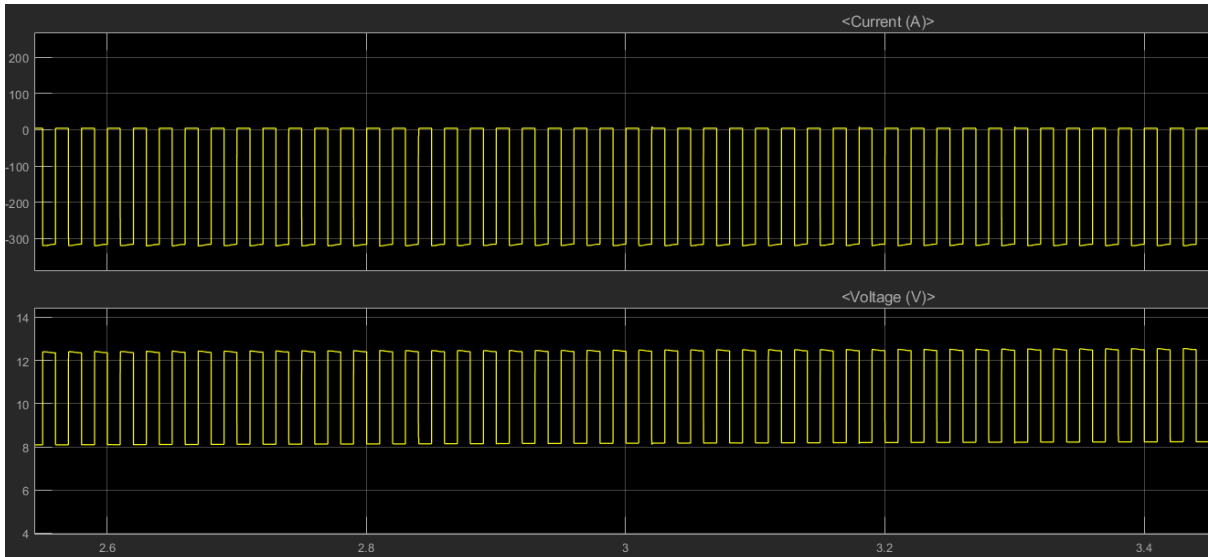


**Figure 29:** Current(A) vs time(s) graph through load



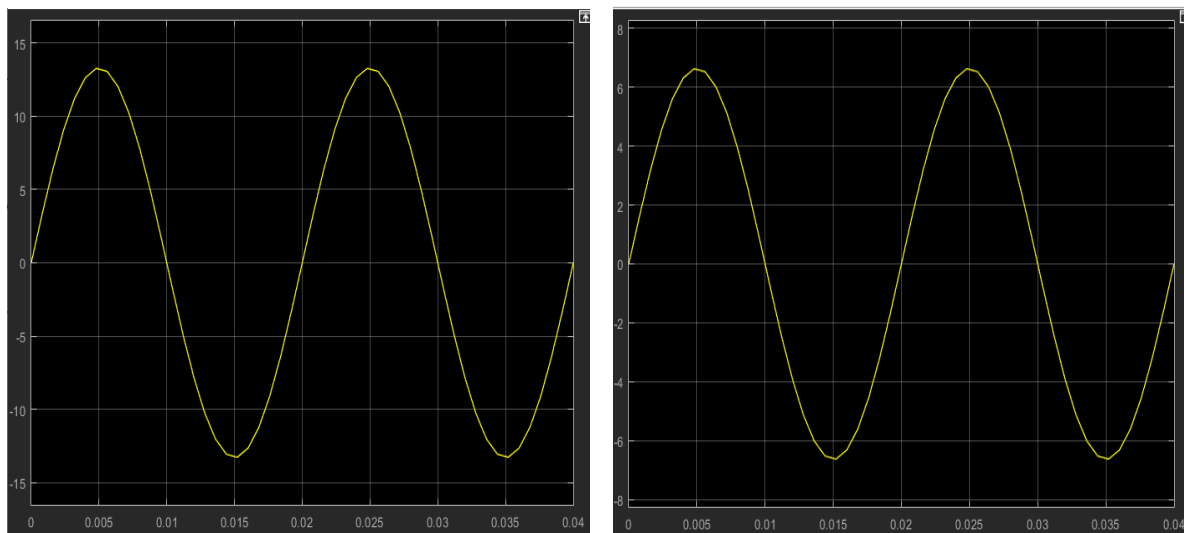
**Figure 30:** Battery is charging by excess wind energy and then discharging to maintenance loads





**Figure 31:** Voltage(V), Current(A)vs time(s)graph of battery while charging

Here, the current is negative because battery is charging from another source(wind-turbine)



**Figure 32:** Voltage(V) vs time(s) graph & current(A) vs time(s) across maintenance load

## 2.5 conclusion

We face different problems at the time of simulating these designs. For example, setting a stable controlling system to reduce dependency on conventional sources, charging and discharging of battery is not possible, assuring 220 voltages across loads. After solving all problems, we compare the three designs to check their performance, sustainability and load sharing percentage to check their validity.

## Chapter 3: Use of Modern Engineering and IT Tool. [CO9]

### 3.1 Introduction

For diverse tasks, we employ various applications. To simulate three models, the ATS system, optimization, performance evaluation, and animation, we utilize MATLAB, Proteus, Homer Pro, and Adobe Illustration. After some trial and error, we choose them based on their adaptability, ease of use, and feasibility. Once more, we must choose solar panels, batteries, inverters, and solar converters based on our needs. power availability, load demand, sustainability, environmental impact, and other factors.

### 3.2 Select appropriate engineering and IT tools

- **System Design**

We have used MATLAB Simulink to design our system because it provides various design blocks and we can write code in the MATLAB function for conditioning different algorithms. In our project designs we worked on a basis of battery state of charge (SOC). Working with battery SOC is much easier with the Simulink tool. Moreover, we had to write codes for conditioning according to the battery SOC. We had also tried to design in another software named Proteus, but this tool does not provide the flexibility to change battery SOC. Since our design is based on monitoring battery SOC, Simulink was the appropriate tool. We also had taken HOMER Pro into account for designing purposes. But in HOMER Pro we cannot get the flexibility to change the parameters of different components blocks easily. As a result, Simulink was appropriate in this manner. Moreover, algorithm wise conditioning is very feasible in Simulink. Thus, we have picked MATLAB Simulink to design our system.

- **Find optimal solution**

Now to find the optimal solution we have used 2 software named HOMER Pro and Simulink. First of all, we have used HOMER Pro for load forecasting and cost analysis. HOMER Pro provides an environment to find those parameters in terms of real values. These types of work can also be done by another tool named PV syst, but HOMER Pro has more flexibility in component selection compared to PV syst. Secondly, we have used Simulink to compare the rate of state of charge of the battery. Simulink provides a graphical surface which can simulate dynamic systems. Thus, it can be summed up that HOMER Pro and Simulink were the most convenient tools to find the optimal solution for our project.

- **Animation making software**

For making animation videos of our multiple design approaches, firstly we work with 'Animaker'. Though making animation is easy in Animaker, there are limited resources for

objects. As we are working with hybrid sources and household applications, a limited number of objects is a major drawback for us. Then we select 'Sketch up'. But sketching is allowed only for drawing pictures. Making videos is not possible here. As there are a number of video editing software for making video clips using picture in picture, we start to sketch different loads and household applications using this software. But it's time consuming, because for each and every picture we need to correct the alignments. So, we switched to another software. Same problem we face at the time of using AutoCAD. Finally, we decided to work with 'Adobe illustration'. This software is really helpful for us. This software allows to draw over the line of any kind of imported picture, then delete the imported one. Furthermore, we can edit and do color on that picture. So, anybody can draw any kind of picture easily in a short time. Moreover, here we don't face any difficulty with alignments. As a result, we are able to draw all loads and hybrid sources in Adobe illustration.

Then for making videos with our drawing picture and editing it we firstly go for 'Kinemaster'. But this software sets a watermark on the top which is not suitable for our project related work. To remove this watermark, we need to go for a professional edition. So, we switched to Wondershare Filmora. Here we do not face any issues with watermarks. Again, changing the direction of current, alternate different parts of a day is easy to set. So, we complete the overall animation here by importing the previous photo that we sketch, indicating the direction of current and alternating different times of a day.

### **Solar panel**

In comparison to polycrystalline and thin-film alternatives, monocrystalline solar panels are the most effective type of panel. Monocrystalline solar panels have an efficiency range of 15% to 22%. As a result, for our main design we choose monocrystalline solar panels and for prototypes we use polycrystalline solar panels.

### **Battery**

Comparing lead-acid batteries to lithium-ion batteries, lead-acid batteries are less expensive and simpler to install. A lithium-ion battery costs twice as much as a lead-acid battery of equivalent capacity. However, if the battery life is compared, a lithium-ion battery outlives a lead-acid battery. For that reason, we select lead acid batteries over lithium -ion batteries.

### **Microcontroller**

The diminutive Arduino Nano is an Arduino UNO that can fit on a breadboard. It is functionally similar to the Arduino UNO in several ways but has a smaller size factor, so we apply Arduino Nano.

### **3.3 Use of modern engineering and IT tools**

#### **Matlab Simulink**

All of our designs are simulated using MATLAB SIMULINK. From there, we choose monocrystalline Greenland solar panels. Connect a battery to it. Use both AC to DC and DC to DC converters as necessary. We connect the input terminal of the controlling system with all sources and the output terminal with all loads when designing our controlling system in MATLAB.

#### **Proteus**

Proteus is used to design ATS. Here we use multiple sources, relays, loads, POT. The Control system of 'Load shared by solar charged battery and main grid' is completed using this software.

#### **Homer Pro**

We check the design validity and complete optimization using Homer Pro. We select loads, hybrid sources from homer pro. Then we select the executed area from there. According to our input, Homer Pro gives us load sharing percentage using those selected sources, levelized cost of energy, net present cost, operating & management cost.

#### **Adobe illustration**

For drawing, painting, typing, cutting, reshaping, and slicing various pictures, we utilize Adobe Illustration. We pull various little and large loads for load sharing. Again, using an Adobe image, we map grid electricity, solar panel, wind turbine, and fuel supply for hybrid sources. There are various tools available in Adobe Illustration's left sidebar. We use pencil, paintbrush, selection, and pen tools among all other tools. We use pen tools to draw various kinds of lines. Then, we use paintbrush tools as we work with different battery states to make the appearance of the battery (charging, discharging, SOC level) understandable. Last but not least, pencil tools are used to alter freehand lines. Selection tools are used for precise positioning and arrangement of loads and sources.

#### **Wondershare filmora:**

A program for editing videos is called Wondershare Filmora. After creating each element in Adobe Illustration, we use picture-in-picture to create several video segments. In essence, our design strategies include a variety of load-sharing conditions. For instance, loads will be shared by PV panels during the daytime when the sun is present. On the other hand, the loads will be supported at night by the backup battery. Wondershare Filmora is the ideal tool to create this kind of scene. Again, this program makes it simple to specify the direction of power flow from

sources to loads. Once more, we use this software to alter the background and provide various effects for various times of the day.

### **Greenland solar panels & solar charge controller**

We are setting up an off-grid solar power system with batteries, so a solar charge controller is a must. By regulating and controlling the output from the solar PV array, a 12V solar charge controller charges the battery while safeguarding it from overcharging or over discharging.

### **Battery**

Solar energy is utilized to its fullest extent using batteries. Solar energy is typically unavailable at night. Therefore, we can store solar energy and then deliver it to loads as needed by using batteries. Once more, solar energy irradiation varies during the day. Therefore, it is safe to store solar energy in a battery to avoid these issues.

### **Arduino Nano**

We use Arduino nano to design our ATS system. Depending on the SOC of the battery, Availability of the sources and load demand ATS system will connect the source to loads.

### **3.4 Conclusion**

After using a variety of programs, we found that MATLAB is the most practical for simulations, Proteus is the best for building automatic transfer switches, Homer Pro is the best for optimization and performance analysis, and Adobe Illustrator is the best for animation. Then, based on our needs, we choose the hardware components. We choose Greenland solar panels with a 12V charge controller in control. Finally, due to its smaller size, we choose Arduino Nano for ATS.

## Chapter 4: Optimization of Multiple Design and Finding the Optimal Solution. [CO7]

### 4.1 Introduction

After finishing our simulation, we must evaluate their performance in light of numerous factors in order to choose the best design. As load sharing is involved, it is important to determine which design distributes the load the most. We also need to think about cost effectiveness, how quickly batteries can be charged or discharged, and a number of other factors.

### 4.2 Optimization of multiple design approach

To analyze the multiple designs solution and to find the optimal design for our project, we have used a software named HOMER PRO. We have built our design circuits in the software and checked different criteria to compare among them. For design 1 and 2 we have built one circuit and for design 3 we have built another one. The circuit diagrams are in the following:

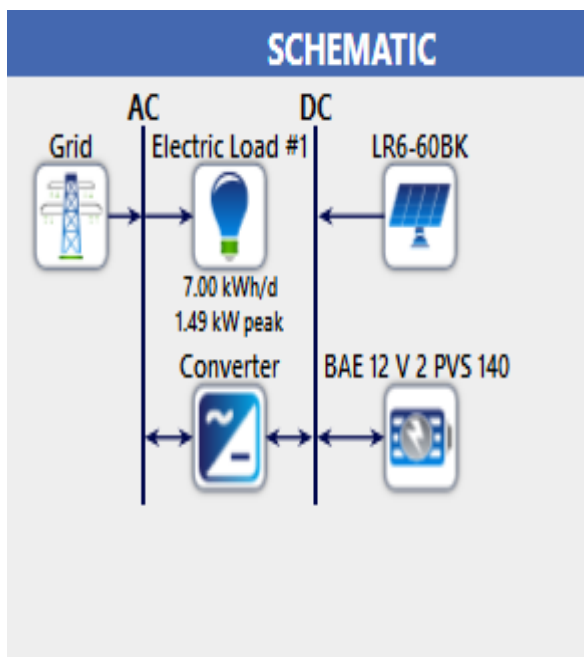


Figure 33: Circuit diagram for design 1 & 2

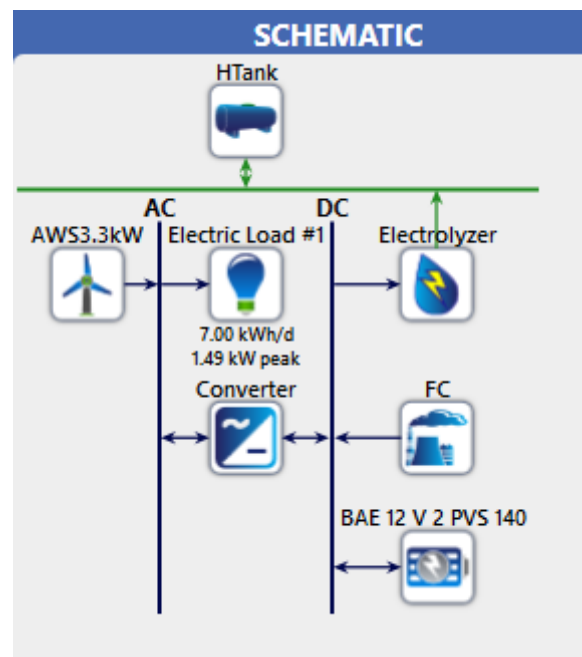
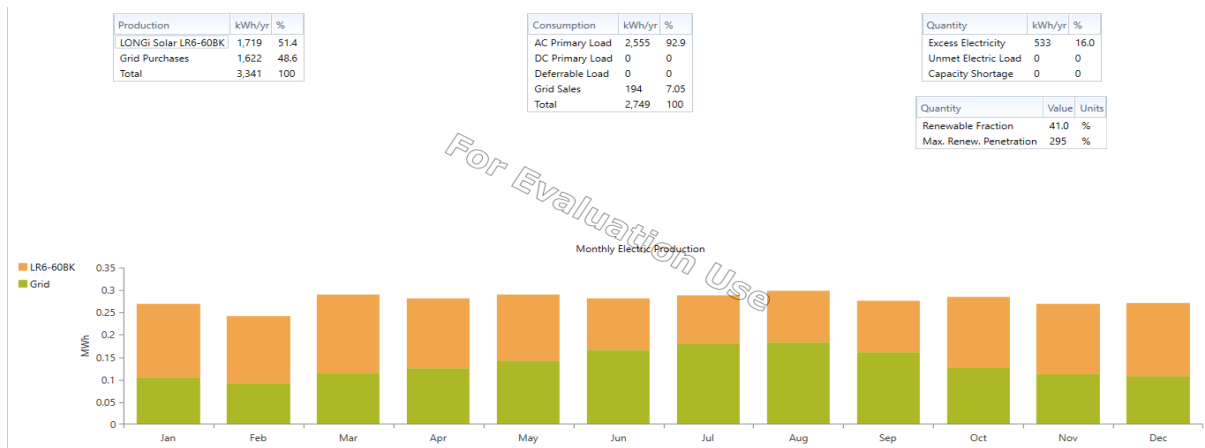


Figure 34: Circuit diagram for design 3

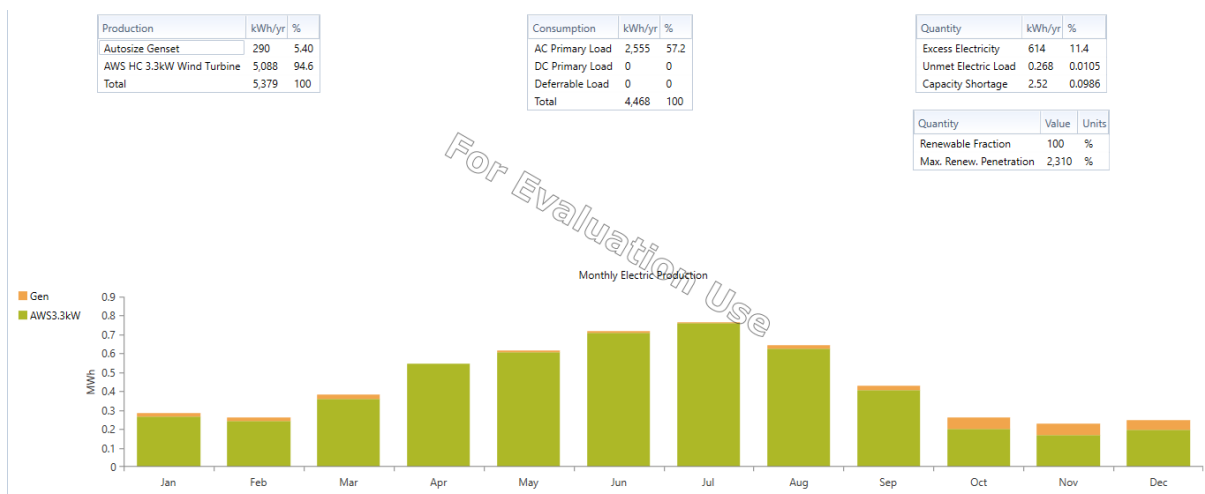
Now, we will analyze some criteria for the designs to check which design is the most suitable for our project.

### 4.2.1 Optimal solution/design based on Load-sharing:



**Figure 35:** Load sharing between conventional grid and solar panels

The above figure is for design 1 and design 2. This bar graph shows load sharing between conventional grid and solar panels. The green color part of this graph indicates the portion of the load shared by the Solar panels and the orange color of the graph indicates the portion of the load shared by the conventional grid. It is clearly visible that load is evenly shared by both the conventional grid and the solar panels. Hence, it can be said that load sharing is happening in a good ratio.



**Figure 36:** Load sharing between Fuel cell and wind turbine

The above figure indicates the load sharing between Fuel cell and wind turbine. Here, green color is indicating the load sharing by the Fuel cell and orange color is indicating the load sharing by the wind turbine. Undoubtedly, it can be said that the load sharing ratio for this system is insignificant. Most of the loads are shared by the wind energy. By comparing the load sharing ratio for these designs, it can be said that design 1 is most favorable.

#### 4.2.2 Optimal solution/design based on Cost:

|                 |            |
|-----------------|------------|
| Total NPC:      | \$1,832.45 |
| Levelized COE:  | \$0.05128  |
| Operating Cost: | \$102.69   |

**Figure 37:** Cost of Design 1 & 2

|                 |            |
|-----------------|------------|
| Total NPC:      | \$6,519.23 |
| Levelized COE:  | \$0.1974   |
| Operating Cost: | \$89.32    |

**Figure 38:** Cost of design 3

Here we can see that total net present cost for design 1 & 2 is much lower than the net present cost for design 3. Cost of design 1 and 2 are almost the same, that is why we considered that one. Levelized cost of energy is also greater for design 3 compared to the design 1 & 2. As a result, we can consider design 1 as the most cost-efficient design.

Furthermore, we can also compare the cost of design 1 with the conventional grid energy cost.

|                 |              |
|-----------------|--------------|
| NPC ⓘ           | \$1,832      |
| Initial Capital | \$504.96     |
| O&M ⓘ           | \$102.69/yr  |
| LCOE ⓘ          | \$0.0513/kWh |

**Figure 39:** Cost of Design 1

|                 |              |
|-----------------|--------------|
| NPC ⓘ           | \$1,982      |
| Initial Capital | \$0.00       |
| O&M ⓘ           | \$153.30/yr  |
| LCOE ⓘ          | \$0.0600/kWh |

**Figure 40:** Cost of conventional grid energy

From the above comparison we can see that Operating & Management (O&M) cost is less in design 1 compared to the grid. In addition, Levelized cost of energy is also lower in design 1 which makes it a cost-efficient design for a long period of time compared to grid energy. Moreover, net present cost for design 1 is also less than conventional grid energy.



### 4.2.3 Optimal solution/design based on state of charge (SOC) of battery:

#### Charging battery:

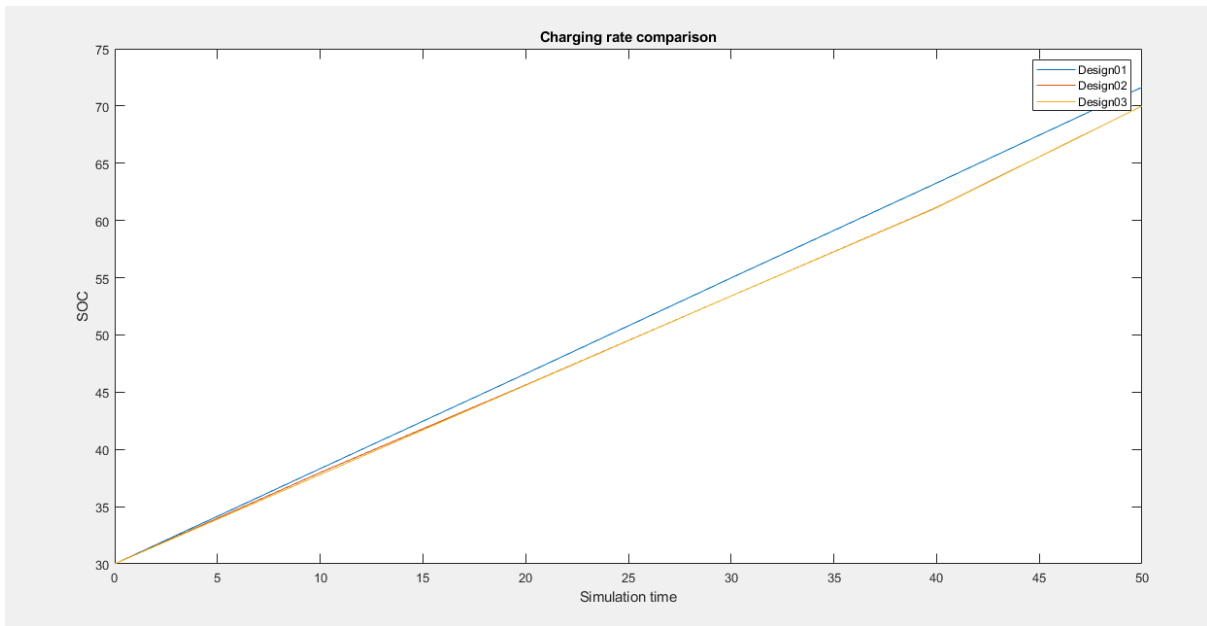


Figure 41: Charging rate of battery

In the above graph it is clearly seen that the battery charging rate of design 1 is higher than the others. Also, battery charging rate for design 2 & 3 is almost the same that are overlapping each other.

#### Discharging battery:

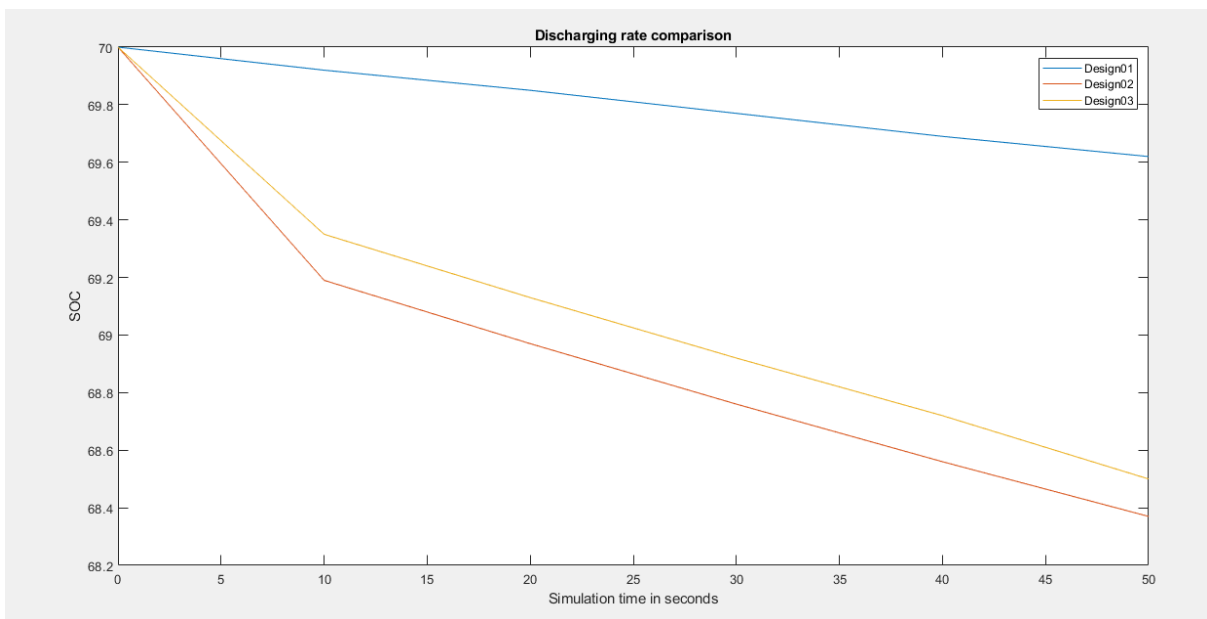


Figure 42: Discharging rate of battery

The above graph shows that discharging rate of design 1 is lower than other designs which makes it better in terms of battery performance.

### 4.3 Identify optimal design approach

#### Optimal solution/design Table:

TABLE 6: Optimal solution/design Table

| Design          | (1)   | (2)   | (3)  |
|-----------------|---|---|--|
|                 | Load shared by solar charged battery and main grid  | Load shared by solar, grid and backup storage   | Load Shared for island by fuel cell & wind turbine   |
| Load-Sharing    | <ul style="list-style-type: none"> <li>● Grid – 48.6%</li> <li>● Solar – 51.4%</li> </ul>                                 | <ul style="list-style-type: none"> <li>● Grid – 48.6%</li> <li>● Solar – 51.4%</li> </ul>                               | <ul style="list-style-type: none"> <li>● Wind – 94.6%</li> <li>● Hydro Fuel cell – 5.40%</li> </ul>                      |
| Cost Efficiency | <ul style="list-style-type: none"> <li>● LCOE: \$0.05128</li> <li>● NPC: \$1832</li> <li>● O&amp;M: \$102.69/y</li> </ul> | <ul style="list-style-type: none"> <li>● LCOE: \$0.05128</li> <li>● NPC: \$1832</li> <li>● O&amp;M: 102.69/y</li> </ul> | <ul style="list-style-type: none"> <li>● LCOE: \$0.1974</li> <li>● NPC: \$6519.23</li> <li>● O&amp;M: 89.32/y</li> </ul> |

Here,

LCOE = Levelized Cost of Energy

NPC = Net Present Cost

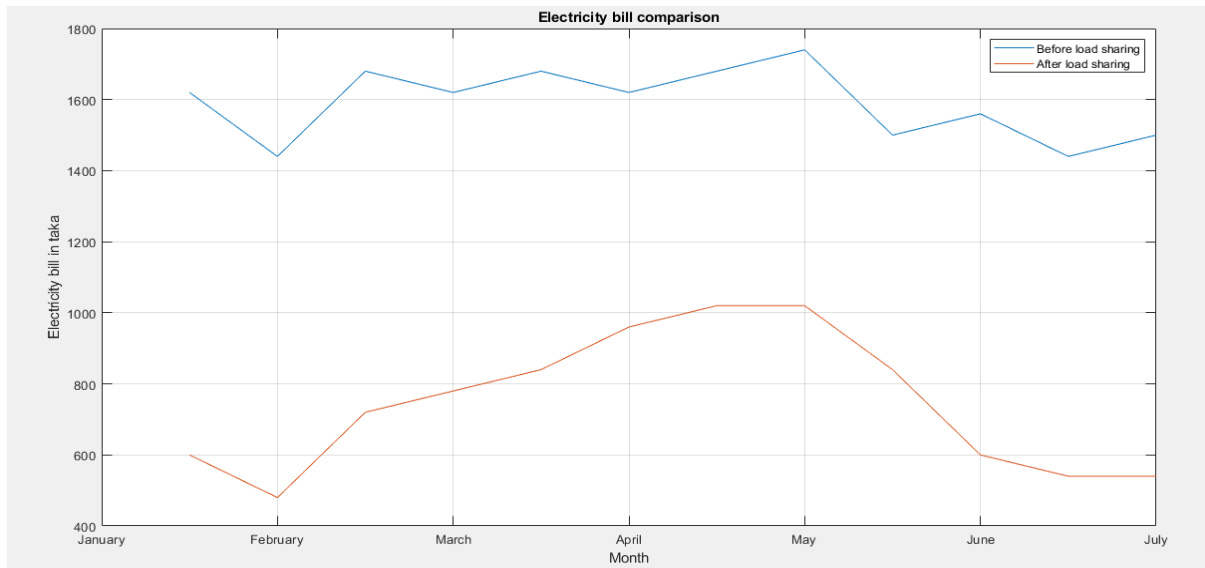
O&M = Operating & Management

By analyzing the above table, we can see that design 1&2 is more optimal in terms of load-sharing and cost efficiency. Furthermore, Fig. 39 & Fig. 40 shows that, battery charging rate of design 1 is higher than others and battery discharging rate is lower than other designs. As a result, design 1 is better than design 2 in terms of battery charging and discharging. Although Fig. 37 & Fig. 38 shows that, initial capital is higher for design 1 but after a certain period of time design 1 will become very cost efficient that the conventional grid energy. Hence, it can be said that design 1 is the most optimal design for our project.

#### 4.4 Performance evaluation of developed solution

load shared by solar charged batteries and the main grid is the most optimized design. Our main purpose is to reduce dependency on grid energy, minimize electricity bill, ensure continuous power supply. Now we need to check whether our optimal design can meet our project adjective or not.

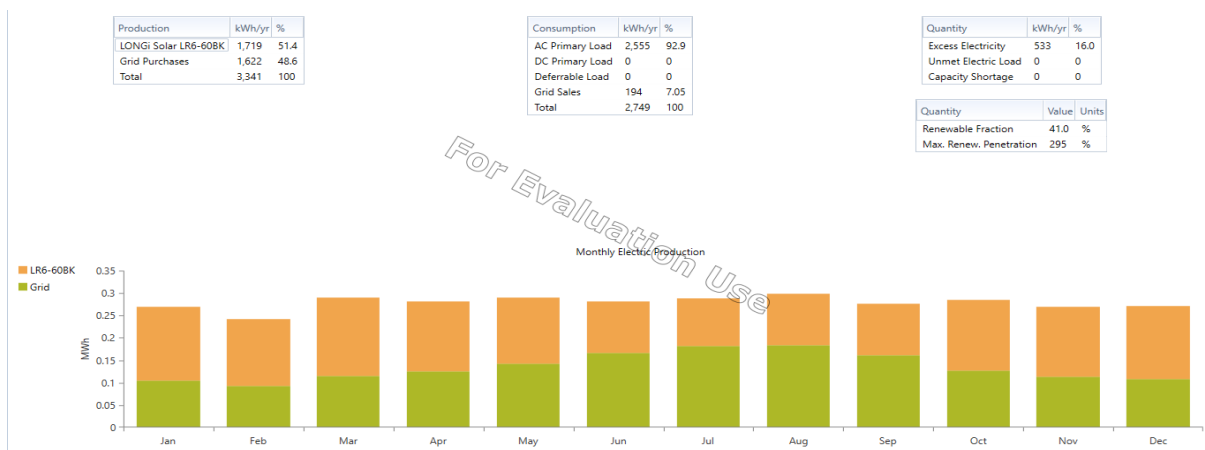
- **Minimize electricity bill**



**Figure 43: Electricity bill comparison**

Here the electricity bill after load sharing is reduced than before load sharing. So that one of our objectives is fulfilled.

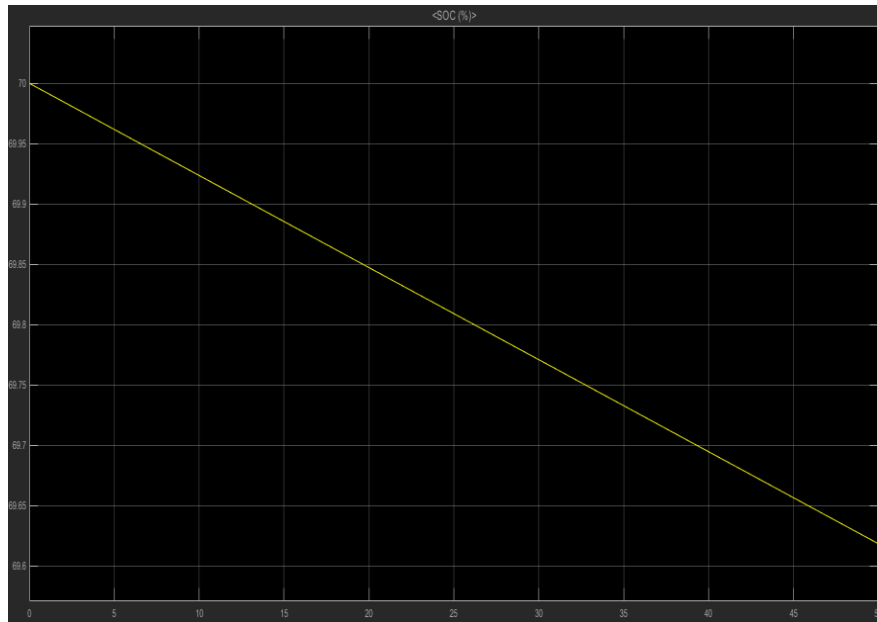
- **Reduce dependency on grid energy**



**Figure 44: Load sharing between conventional grid and solar panels**

Here, a large amount of load is shared from solar energy. More specifically, 48.6% energy is shared from grid energy and 51.4% energy is shared from solar. So that dependency on grid energy has decreased significantly.

- **Ensure uninterrupted power supply**



**Figure 45:** Battery is discharging

If the grid is unavailable and  $SOC \geq 30\%$ , then ATS connects the battery to loads to supply energy which ensures continuous power supply.

#### **4.5 Conclusion**

Following optimization, it is clear that solar and grid load sharing goes beyond wind and fuel cell technology. Once more, design 1 & 2 have lower operating & administration costs, levelized Cost of Energy, and net present Cost than design 3. Last but not least, design 1 charges at a faster rate than battery 1. Therefore, load sharing between the main grid and solar-charged batteries (design 1) is more practical and efficient than load sharing between the grid and backup storage (design 2) and load sharing for an island using fuel cells and wind turbines (design 3).

## Chapter 5: Completion of Final Design and Validation. [CO8]

### 5.1 Introduction:

To enable the allocation of load in response to increasing demand, a dynamic switching system is necessary to facilitate the switching between sources. With that aim we had designed a switching algorithm and wrote a code to run a microcontroller which will in turn operate the switching system. Since we are developing a prototype for the completion of final design hence, we chose an Arduino Nano for microcontroller operation. As had previously designed the switching circuit in proteus it was required to make a PCB layout for the circuit which we did using Eagle AutoCAD. The entire design and operation process of the circuit was impacted by many technical issues and required a lot of efforts to rectify our approach.

### 5.2 Completion of final design:

The switching circuit we had designed in proteus was basically a demonstration of our prototype ATS (Automatic Transfer Switch) system. In the proteus design, we ran the Arduino code to simulate the switching operation between two DC sources which represent two batteries and an AC source which represents the grid connection. However, in the main prototype design we had to add more relays to control the inverters which were required in the first place for DC-AC conversion as we were needed to run AC loads.

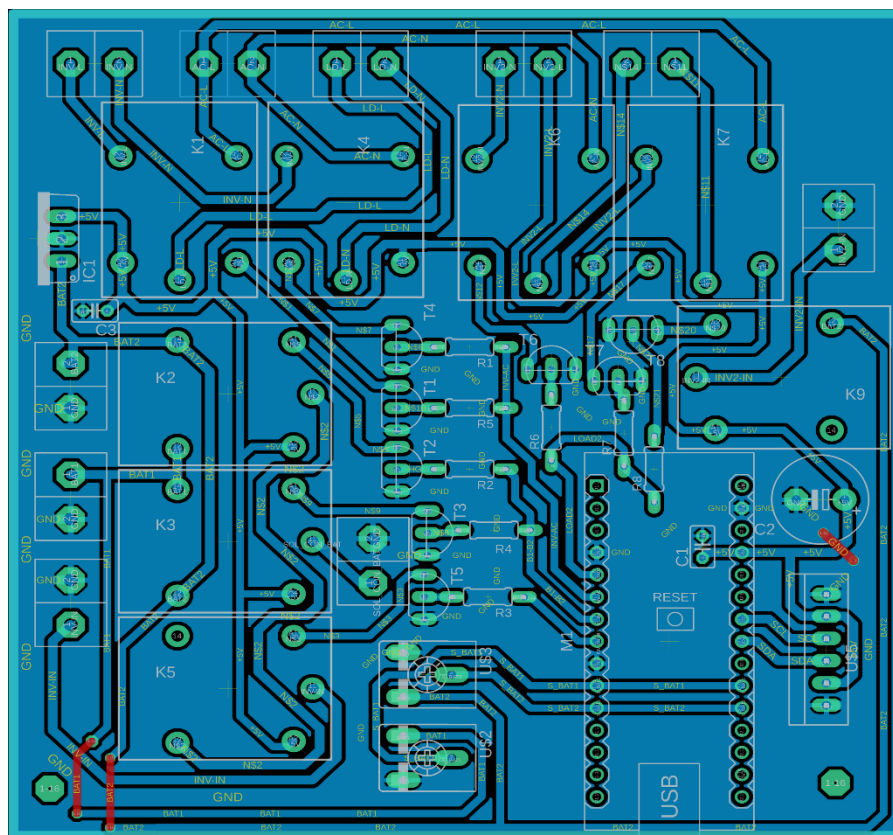
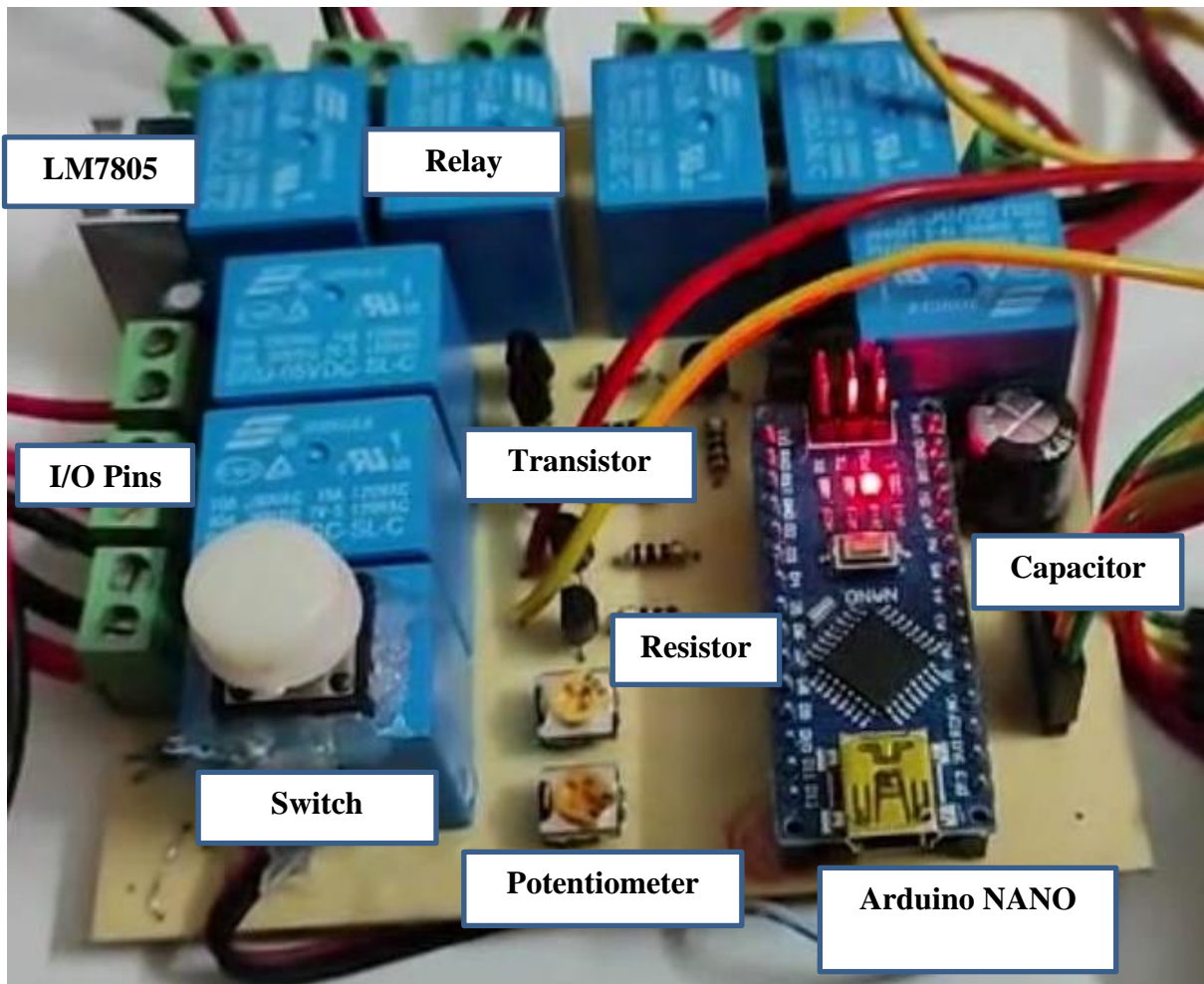


Figure 46: PCB layout of the ATS system



**Figure 47:** Prototype ATS system

The ATS system comprises not only essential components such as relays and microcontrollers but also several other necessary elements that were incorporated in its design. A couple of potentiometers was used to regulate the battery voltage which was given as input to arduino microcontroller. The potentiometers work as voltage dividers since we can not provide more than 5V input to the microcontroller.

Furthermore, an LM7805 voltage regulator and a capacitor was used to provide stable 5V power input to the microcontroller.

In the next part, we designed the load system. Although we had two distinct types of loads in our system (regular loads and small loads), for the prototype we have used two similar light bulbs as our loads.



**Figure 48:** Load system

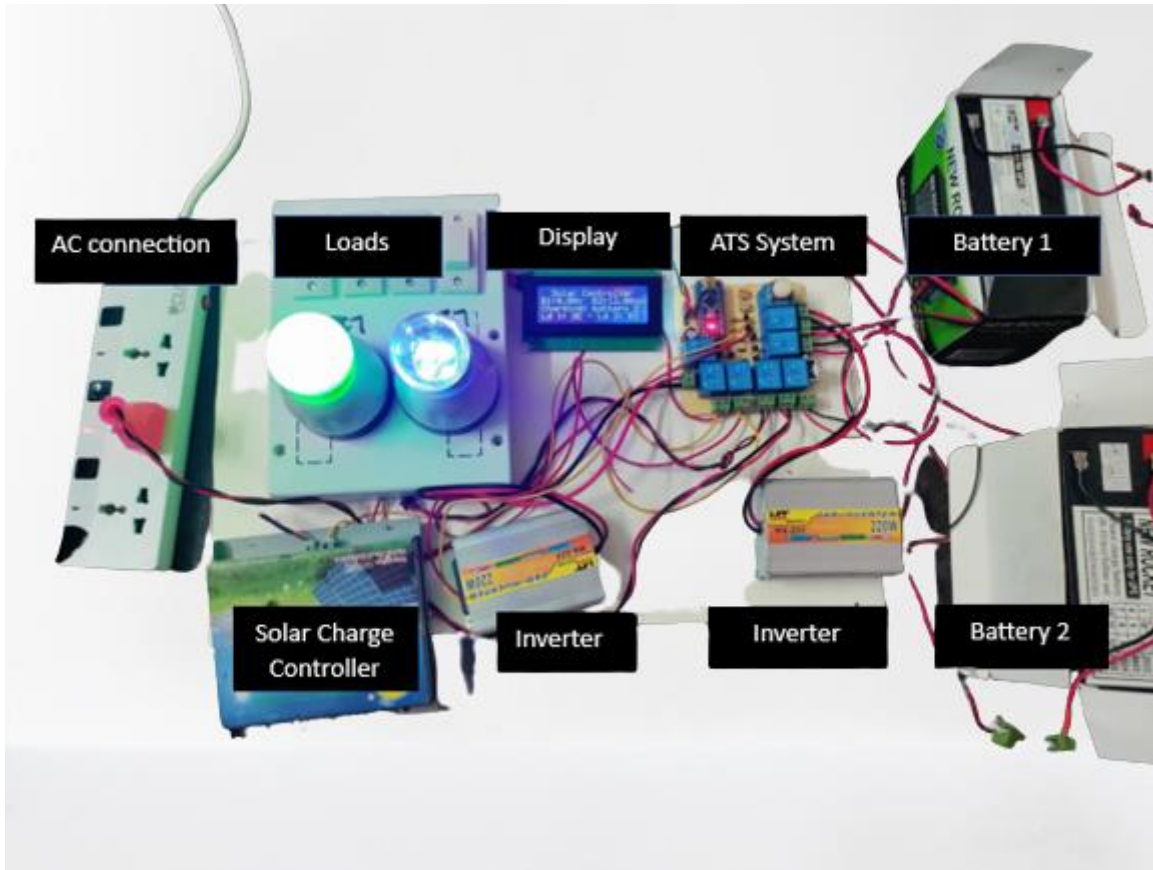
Furthermore, we had used an I2C display for showing necessary information about the system.



**Figure 49:** I2C display

In addition to these components, we had used a solar charge controller to regulate solar panel output and charge the system batteries. The final prototype design we have constructed is displayed below:





**Figure 50:** Final Prototype Design

### 5.3 Evaluate the solution to meet desired need

The dynamic load sharing process between different sources depends on the availability of sources. In the presence of solar power, the batteries will maintain a sufficient charge to operate the loads; however, if solar power becomes unavailable, the grid power will be utilized instead. Furthermore, with the increase of load demand the battery SOC will decrease; as a result, a battery that means solar power alone cannot support the load. In this case, the ATS system will switch to grid power in order to supply power to the loads. The increasing load demand in the system is realized through the operation of the switch. Whenever we press the switch the second bulb is turned on means the load demand is increased and for that the ATS system will balance between the 2<sup>nd</sup> battery and grid depending upon the battery SOC.

The entire switching system depends on the battery state of charge. If the battery SOC drops below a pre-determined threshold, the system will switch between the sources.

For our design, the State of Charge threshold of the battery is considered 30%. Through, battery charger and display we have come to know that the corresponding voltage of 30% SOC is 10.5V. Hence, the system will execute commands as soon as the battery voltage reaches 10.5V.

As we had run the system, we observed it performing under different conditions and switching between sources. The entire working is demonstrated by the following table:



TABLE 7: Load sharing and Auto Transfer Switch functionality verification

| Conditions  | Source Running      | Loads running  | Load shared by sources |
|---|---------------------|----------------|------------------------|
| Battery 1 SOC > 30%, Battery 2 SOC < 30%                        | Battery 1           | Load 1         | Battery                |
| Battery 1 SOC > 30% Battery 2 SOC > 30%                         | Battery 1           | Load 1         | Battery                |
| Battery 1 SOC < 30% Battery 2 SOC > 30%                         | Battery 2           | Load 1         | Battery                |
| Battery 1 SOC < 30% Battery 2 SOC > 30% and load 2 is turned on | Battery 2           | Load 1, Load 2 | Battery                |
| Battery 1 SOC >30% Battery 2 SOC > 30% and load 2 is turned on  | Battery1, Battery 2 | Load 1, Load 2 | Battery                |
| Battery 1 SOC >30% Battery 2 SOC< 30% and load 2 is turned on   | Battery 1, Grid     | Load 1, Load 2 | Battery, Grid          |
| Battery 1 SOC< 30% Battery 2 SOC< 30%                           | Grid                | Load 1         | Grid                   |
| Battery 1 SOC < 30% Battery 2 SOC > 30% and load 2 is turned on | Grid                | Load 1, Load 2 | Grid                   |

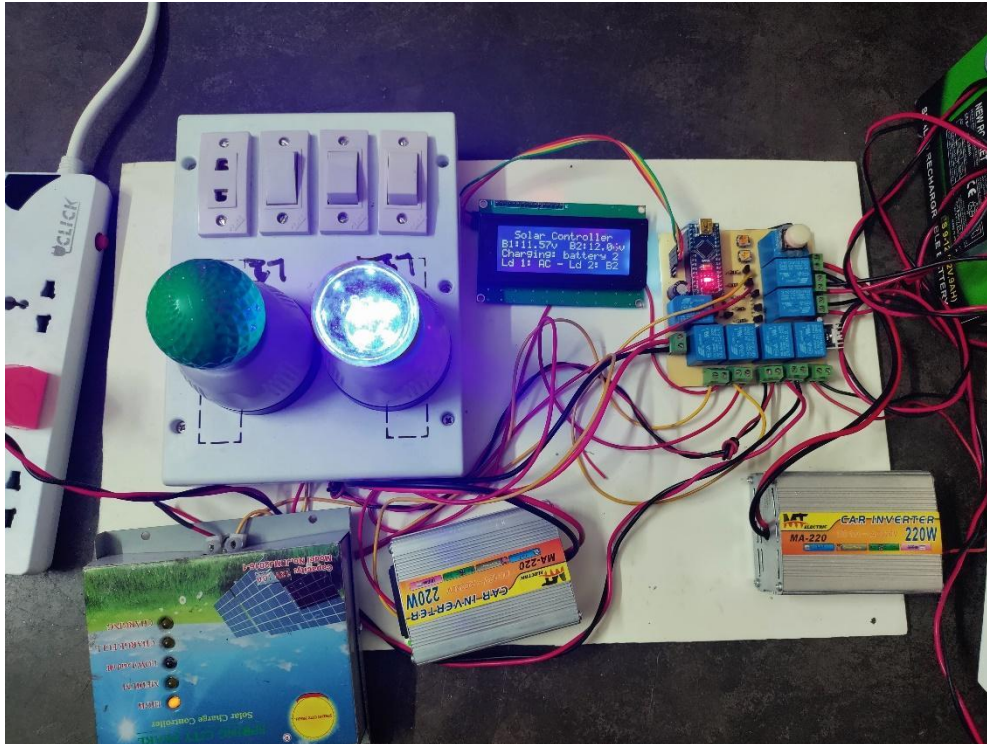
Our ATS system was required to switch between different sources based on the battery SOC which was observed during several tests. The load sharing operation took place when battery 1 SOC was more than 30% and battery 2 SOC was less than 30% and the switch was turned on. At that specific time, both battery and grid were powering the loads.

Test case scenarios:

As we had run the system to check the working of the ATS system, the system functioned properly as per the switching algorithm.

Case-1:

If we look closely into the figure, it is visible that battery 1 is completely drained out hence showing 0V on the display. As a result, load 1 is connected to AC source and battery 2 is charging through the solar charge controller. On the other hand, battery 2 has sufficient SOC (voltage:11.97V) to support the load and the switch is also pressed thus we can see from the display that load is connected to battery 2 and the bulb is on.



**Figure 51:** Load 1 is connected to the grid and load 2 is powered by the backup battery

**Case-2:**

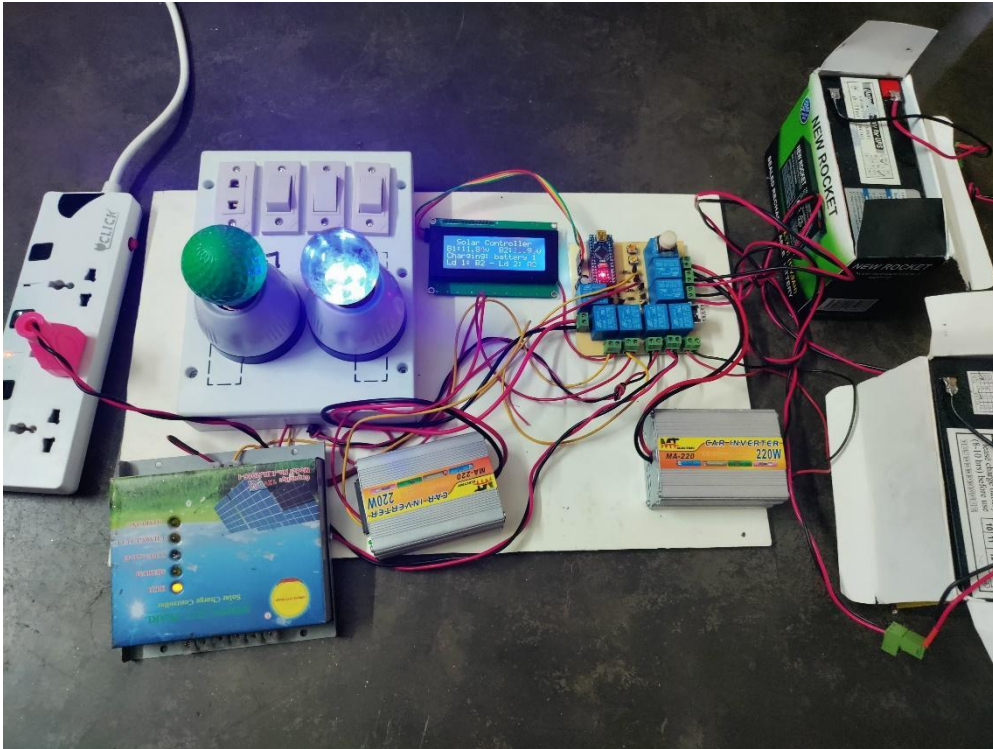
In this case, battery 1 has sufficient state of charge thus load 1 is connected to battery 1 and the bulb is on. Whereas battery 2 state of charge is lower than the threshold, as a result it is charging from the solar charge controller. Since, the switch is not pressed the second bulb i.e load 2 is turned off



**Figure 52:** Load 1 is powered by the main battery and load 2 (large loads) is turned off

Case-3:

In this step, load 1 is connected to battery 2 while battery 1 is charging from the solar charge controller. At the same time, load 2 is turned off hence the bulb is off.



**Figure 53:** Load 1 is powered by the backup battery and load 2 (large loads) is turned off

## 5.4 Conclusion

Our main objective was to design an ATS system that will perform to materialize load sharing between hybrid sources. The ATS system we have constructed works as per the algorithm. Despite running and verifying our system for different conditions, there were times the systems malfunctioned and different components went off due to short circuits. Hence, we needed to be cautious every time when conducting the tests. Moreover, as the system works depending upon the battery SOC it is imperative to maintain a stable voltage in order to switch between the sources properly. Unfortunately, the battery voltage fluctuates a couple of times causing the system to switch between sources continuously without settling for a specific source. These are some of the issues we have taken notes about on which we need to work in future in order to make our system more reliable and sustainable.

## Chapter 6: Impact Analysis and Project Sustainability. [CO3, CO4]

### 6.1: Introduction:

Hybrid energy systems have emerged as a prominent alternative of conventional energy sources in recent years. It will provide a constant access to electricity for homes and communities that are not connected to the national power grid. The benefits of hybrid energy systems are not just providing electricity, they can also help to reduce greenhouse gas emissions, improving public health and boost economic growth.[16] However, to ensure the sustainability of these systems, it is very necessary to conduct an impact and sustainability analysis. So that we can evaluate the social, economic and environmental effects of the system in the long run. This analysis can help us to identify and eliminate potential challenges and hazards. It also provides valuable insights into the system's effectiveness and give us suggestions to find out the ways to increase its sustainability.[16] In this context, the main project focuses of our project is making a hybrid energy system that aims to make a contribution to the public benefits by providing a sustainable solution of energy crisis. By ensuring the highest level of sustainability of our project, we aim to support global efforts to fight climate change and reduce greenhouse gas emissions.

### 6.2: Assess the Impact of Solution:

#### **Environmental:**

It is true that conventional energy sources like coal, natural gas and oil boosts our economy to some extent, but they have a huge negative social, environmental and economic effects on our nation. These elements are called fossil fuels. They emit harmful gases like, carbon dioxide, carbon monoxide, sulfur dioxide, mercury, cadmium etc. [17] On the other hand, our project is based on solar energy and we all know that it has zero carbon emission. That is why our project will help the nature to grow in a clean and safe way. Additionally, conventional energy system emits harmful gases at an approximate rate of 87%, which helps to increase the greenhouse effect and deforestation.[18] Toxic elements released from fuel combustion which caused acid rain and soil erosion. Not only that but also, when those toxic elements react with food, they can cause deadly diseases. On the other hand, our project has the capacity to lowering the emission of dangerous substances. As our project provides more green energy, it will help to reduce carbon emissions. As a result, it will help to eliminate the possibilities of climate change and global warming.



**Health:**

Hybrid energy systems are combination of two or more renewable energy sources. They have the potential to benefit public health by lowering air pollution and expanding access to clean energy. One of the key benefits of hybrid energy systems is, they have the ability to replace fossil fuel-based energy sources like diesel generators. These diesel generators produce hazardous emissions which can seriously harm human health.[19]

Studies show that breathing in polluted air can result in respiratory, cardiovascular, and other health issues. The air quality can be improved and the health hazards can be minimized by reducing those harmful elements from the air. [20]

According to WHO, there are about 7 million people die each year from illnesses like stroke, heart disease, lung cancer, chronic obstructive pulmonary disorders and others. [21] Burning of coal produces emissions per kilowatt-hour (CO<sub>2</sub>E/kWh) in a range from 1.4 to 3.6 pounds while burning natural gas produces emissions per kilowatt-hour (CO<sub>2</sub>E/kWh) in a range from 0.6 to 2 pounds. However, over the year of their lifetime, each of solar and wind energy generates 0.07 to 0.2 pounds of CO<sub>2</sub>E. [22].

In our ideal load-sharing configuration between solar-charged batteries and the main grid, two batteries are employed. These batteries release the energy they store in solar panels to the load. We can maximize the use of solar energy by storing surplus energy in one battery while the other discharges to the load. Additionally, one of our primary goals is to make sure that there is a continuous supply of electricity to the loads both during the day and as much of the night as is practical. Our initiative attempts to lessen reliance on traditional energy sources. This technique reduces CO<sub>2</sub> emissions and promotes a healthier lifestyle by relying less on the grid and more on renewable energy.

By using our project, the people of Bangladesh will have better health as a result of using hybrid renewable energy.

**Safety:**

We used a single control system for the operation of two batteries simultaneously in our design. We named it automatic transfer switch (ATS). In order to avoid any blackouts, the grid will be connected to the loads if the state of charge (SOC) of both batteries drops below 30%. As a result, the loads which were shared between the main grid and the solar-charged battery receives a constant power supply. Additionally, since the PV panels are not connected directly to the loads, there is less chance of electric shock, burns from electricity, power outages and overflow of current. Our project allows us to add additional emergency or security lights to our home. By providing a stable supply of electricity, we can ensure that the security lights stay on at night time. Additionally, we can install CCTV cameras to enhance security and discourage criminal activities since we have a reliable access to sufficient electricity.

## **Social and Cultural:**

Bangladesh possesses a vibrant culture and social norms. We have numerous religious and cultural festivals to celebrate throughout the country. These occasions generally involve family gatherings, but frequent power outages disrupt these cherished moments. Our main objective is to make sure of a steady electricity supply of for homes. By the help of our project, we can do this. With the help our project, our consumers will be able to celebrate holidays without any interruption and it will encourage a positive social contact across the nation. Additionally, our project will help people to fulfill their religious duties by creating a calm environment during prayer times. For example, during the Muslim holy month Ramadan when families gather for iftar and sehri meals. For a country like Bangladesh, a steady electricity supply that our project provides is very important.

Furthermore, we install a dual battery system for energy storage. It allows us to store more power than other competitive products. As a result, we are able to store and deliver more electricity during peak demand and we can build a stable electricity supply. As a result, we can eliminate more social problems.

Finally, our project does not hamper any social and cultural norms of our country.

## **Legal:**

In our project, we are working with PV panels and grid energy for load sharing. As a result, we need installation area under the household complex. Normally, we prefer rooftop area. For that, we need some permissions.

- **Permission for land:** As we will install our solar panel top of the building, so that we need the permission of that particular building owner.
- **Mutual agreement between stakeholders:** As we are working with people. So, we need a written mutual signed agreement with our stakeholders to avoid further legal issues.

We also need some other permissions for execution of our project and some more legal things to do. We need to take care of some major precautionary measures.

- A pre-feasibility study of the site is required and it must include details about the land's type and category, communication capabilities, anticipated solar project capacity, and infrastructure for supplying the generated electricity to the home. We must identify any publicly or privately owned land that would be suitable for the project. [23]
- According to the Renewable Energy Policy, business owners will need to obtain a waiver certificate or license rather than a license from the Bangladesh Energy Regulatory Commission (BERQ) in order to develop a solar park with a capacity up to 5 MW. A license for a minimum of 20 years may be provided with the requirement that

it be renewed annually in order to encourage alluring investments for carrying out such projects.[23]

### **Economic:**

Bangladesh has to import a huge amount of fossil fuel from other countries due to the rising demand of electricity [24]. Gas and oil prices is aggressively rising. As a result, it is disturbing the society by creating an unstable economic situation in the country. Natural resources are also in shortage of supply. If we do not practice resource conservation and start using of renewable sources, we will soon run out of natural resources. While fossil fuel prices won't decrease if power is produced from renewable sources. Eventually, living standards will be higher. People can save some electricity by using our project and that electricity can be used for other crucial projects. Additionally, as they don't have to generate extra electricity, the government can save money. People can also save money by saving electricity bills. They can use this money for personal improvement

### **6.3: Evaluate the sustainability:**

#### **Sustainability evaluation by SWOT analysis:**

SWOT stands for Strengths, Weaknesses, Opportunities, and Threats, and so a SWOT analysis is a technique for assessing these four aspects of a project. The primary objective of a SWOT analysis is to develop a full awareness of all the factors involved in making a project. SWOT analysis is a tool that can help to analyze a project's current condition, and to devise a successful strategy for the future. By using SWOT analysis to discover recommendations and strategies, with a focus on leveraging strengths and opportunities to overcome weaknesses and threats. So, a SWOT analysis of our project is in the following:



TABLE 8: Sustainability analysis by SWOT analysis.

|   |   |
|---|---|
| <b>Strengths</b>  | <b>Weaknesses</b>   |
| <ul style="list-style-type: none"> <li>▪ Availability sunlight</li> <li>▪ Environment friendly</li> <li>▪ Durability</li> <li>▪ Low maintenance cost</li> <li>▪ Reduce electricity bills</li> <li>▪ Less health Risk</li> <li>▪ Reduce dependency on fossil fuel</li> </ul> | <ul style="list-style-type: none"> <li>▪ Weather dependency</li> <li>▪ Cost</li> <li>▪ Expensive batteries</li> <li>▪ Uses large space</li> </ul>   |
| <b>Opportunities</b>  | <b>Threats</b>  |
| <ul style="list-style-type: none"> <li>▪ Smart grid integration</li> <li>▪ Plan for Commercial project</li> </ul>   | <ul style="list-style-type: none"> <li>▪ Safety hazards</li> <li>▪ Electric prices stagnating, or worse, getting cheaper</li> <li>▪ Danger of fire</li> <li>▪ Danger of toxic chemicals.</li> </ul> |

**Explanation:**

**Strengths:** First strength of our project is that the system we want develop uses sunlight as its main energy source. Since sunlight is a free energy source, it is a very strong strength of our project. Secondly, our project is environment friendly. As we know using fossil fuel is harmful for our environment also burning coal, gasoline, and gas contribute to at least 87% of the CO<sub>2</sub> released into the air. So, using photovoltaic system does not have any harmful aspects in environment. Moreover, PV panels have very large longevity so in terms of durability this project has a very strong side. In addition, PV panels does not need any maintenance but cleaning. Finally, Using the system can reduces electric bills in long run.

**Weaknesses:** First of all, dependency on weather is the biggest barrier to our project. Without good sunlight our PV system can-not have its highest efficiency. Secondly, solar batteries are very expensive. After 2 or, 3 years battery can-not perform accordingly. So, after a certain

period of time batteries need to be changed which is a strong weakness of our project. Furthermore, our system needs a large space to install, in a small space we can-not install solar panels. It needs a free large space in roof-top.

### **Opportunities:**

Since solar power is abundant and we are utilizing it by producing electricity in our project, here lies opportunities to increase the efficiency of the system. If we can somehow produce more energy than what we need by applying some advanced algorithms then there may be a prospect of energy trading. A smart grid integration is therefore implementable which will help consumers become producers and a smart meter will be required to adjust electricity bill based on the energy received from the grid and the additional energy distributed from the energy storage to the grid.

A commercial implementation of the project is feasible since the installation cost is not too high compared to other means of energy back-ups like diesel generator. Also Return of Investment (ROI) is higher since solar panels have a longer life span. The customers can highly benefit from the system as it will drastically reduce the electricity bill. Additionally, renewable energy projects are appreciated by the government. As a result, mass implementation of such projects might make the government consider reducing components price by allowing duty exemption.

### **Threats:**

In presence of sun light, solar panel continuously produce direct current. If solar panels are not grounded properly, it causes electric shock. As a result, at the time of cleaning these solar panels, human body will be considered as ground which causes electric shock. Again, broken solar panel causes electrocution. If water is sprayed over the broken parts of the solar panels, and then touched, then this may result in cardiac arrest or brain damage. Secondly, if solar power generation increases, then grid energy will be saved that reduces electricity bill. But increasing solar energy may result in increasing the price of grid energy. As a result, the money one wants to save by using renewable energy will be spent and that makes people discourage to use renewable energy. Thirdly, in solar panel there is danger of fire because of the loose and poor connection of wire. Along with that over-heating and overcharge of battering may result in fire. Wrong installation process is also responsible for rooftop fire. Although we pretend that PV energy is safe for human and environment, but arsenic, cadmium and others toxic chemicals are used for manufacturing panel and batteries. Again, they produce toxic chemical biproduct such as hexafluoride, silicon tetrachloride, sulfur etc. which are injurious for health and threatened for environment.

### Evaluate project sustainability by decision matrix:

We have created some criteria to evaluate quantitative sustainability. We have given numbers and made an average of it to make this quantitative decision box.

TABLE 9: Quantitative analysis by decision matrix.

| Selection criteria         | Design approach 1 | Design approach 2 | Design approach 3 | Percentage |
|----------------------------|-------------------|-------------------|-------------------|------------|
| Environment friendliness   | 12/12             | 08/12             | 10/12             | 12         |
| Efficiency                 | 12.5/14           | 5.5/14            | 08/14             | 14         |
| Ease of use                | 7.5/8             | 7/8               | 06/8              | 8          |
| Cost                       | 14/18             | 16/18             | 16/18             | 18         |
| Ease of manufacture        | 10/12             | 11/12             | 10.5/12           | 12         |
| Durability                 | 20/20             | 19/20             | 18.5/20           | 20         |
| Availability of components | 15/16             | 15/16             | 14.5/16           | 16         |
| Total                      | 91                | 82.5              | 83.5              | 100        |

This table shows us the results of evaluating three different design approaches for our project based on specific selected criteria. The criteria include environment friendliness, efficiency, ease of use, cost, ease of manufacture, durability and availability of components. The table displays the percentage score of each approach for each criterion and the total percentage score. The higher the percentage score, the better the approach performs based on the given criteria. For example, if we take the parameter environment friendliness, as our project is operating with solar energy and it is a clean energy. Moreover, our project will give more support than other approaches. As a result, our project can save more fossil fuel. That is why our project is more environment friendly. Then, come to the parameter named efficiency. As we are using two batteries, our project will ensure us a steady electricity supply. As a result, our project is more efficient. As our project is using solar energy and it is free and a never-ending energy source until the end of our planet Earth, our project will never run out of energy sources. Eventually, our project will become more durable than others. Finally, we can say that approach 01 has the best performance with a total score of 91%. Then, the 2<sup>nd</sup> best performance has the approach 03 with a score of 83.5%. Finally, approach 02 has the lowest performance with the lowest

score of 82.5%. This table helped us to make an informed decision to select the best design approach based on the given selection criteria.

So, from the decision matrix, we can say that “Design approach 01” gained the highest number among these 3 designs. So, “Design approach 01” is relatively more suitable among other designs.

#### **6.4: Conclusion:**

To sum up, a hybrid energy system project can have numerous positive impacts on various aspects of society, economy, culture, law and health. From a societal perspective, hybrid energy systems can provide a reliable source of electricity in remote or underdeveloped areas. They can also make a long-term savings and create new job opportunities in the renewable energy sector. Hybrid energy systems can promote sustainable behaviors and reduce carbon emissions, thus contributing to cultural change. They also have environmental benefits by lowering greenhouse gas emissions and preserving natural resources. Hybrid energy systems can comply with environmental laws, assist in policy creation, and improve air quality to benefit public health. To ensure sustainability, it is important to consider some important factors such as efficiency, maintenance, and environmental impact. Though it has high initial costs, it can give us a long-term benefit. These long-term benefits can outweigh the drawbacks and can make it a desirable choice for a more sustainable future. As technology advances, hybrid energy systems are expected to become more efficient, affordable and sustainable. In a long run, it will play a vital role in the global transition to sustainable energy. The sustainability of a photovoltaic system was evaluated by using SWOT analysis. This SWOT analysis identified strengths, weaknesses, opportunities, and threats. Although the project has advantages like using a free energy source and having low maintenance costs, it also has weaknesses like dependence on weather and expensive batteries. There are opportunities for improvement, such as smart grid integration and reducing component costs, while threats include safety hazards and rising grid energy prices.

## **Chapter 7: Engineering Project Management. [CO11, CO14]**

### **7.1: Introduction:**

Effective engineering project management is very crucial for the timely and budget-friendly completion of engineering projects. It involves organizing and managing resources to meet specific engineering goals.[25] Those who manage engineering projects must possess technical, communication, and leadership skills, and oversee the project from start to finish, manage the project team, and keep all stakeholders informed throughout the project's lifecycle.[26] We emphasized the significance of project management skills in engineering and used these skills to complete our Final Year Design Project (FYDP). The project was divided into phases such as problem definition, project planning, project management and execution. We utilized effective project management practices to ensure the project's completion within budget and on time. We were organized and each member was assigned specific tasks based on their individual strengths. Regular group meetings were held to monitor progress and a regular communication was maintained with our ATC panel for their valuable guidance. This chapter provides an overview of these phases and how efficient project management practices were utilized to achieve the project's timely completion within the specified budget and timeline.

### **7.2: Define, plan and manage engineering project:**

#### **7.2.1: Defining project management:**

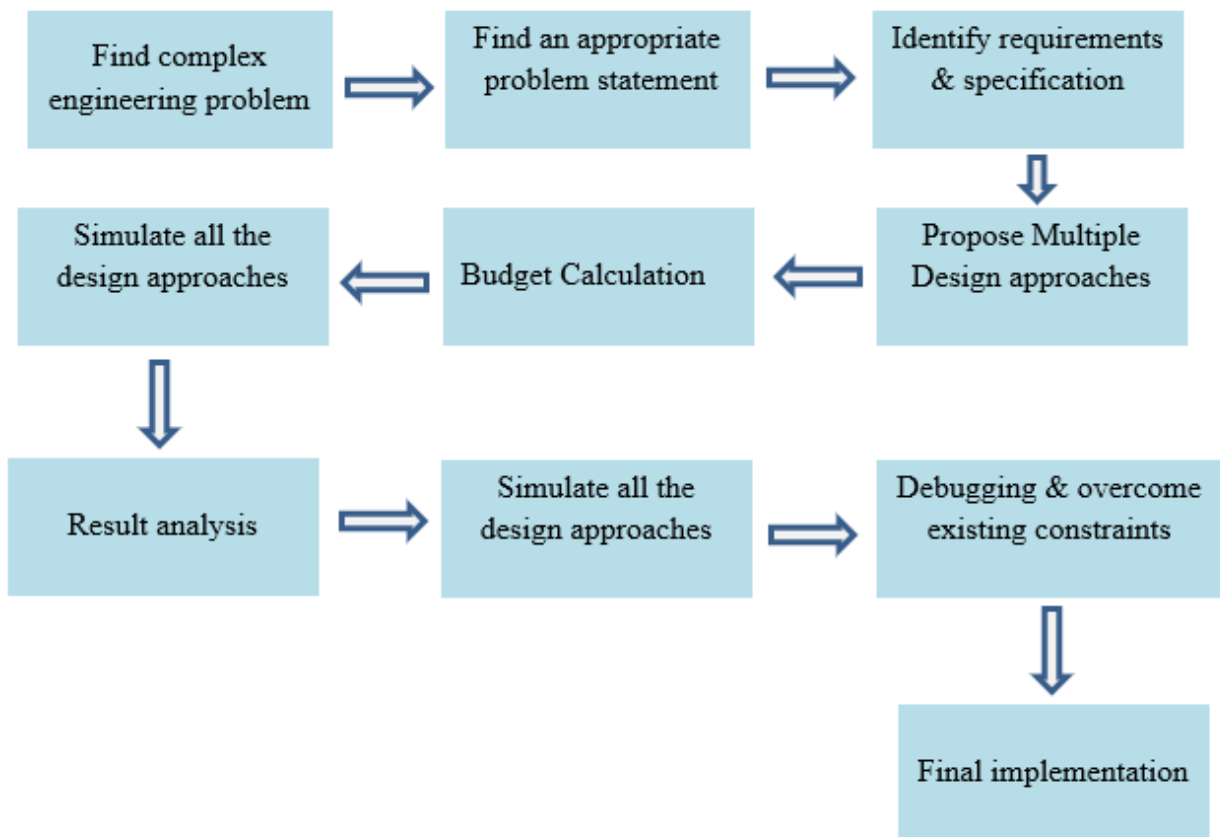
Defining an engineering project starts with identifying a specific problem or requirement and proposing a solution. When we are proposing the solution, we have to consider the project's objectives, limitations and available resources.[26] The definition of a project leads us to the foundation for successful planning, management, and execution.[26] A clear project description helps to align stakeholders, establish a well-defined project scope and establish success criteria. To effectively manage an engineering project, we require extensive knowledge of project management and we need some essential skills like collaboration, risk assessment, stakeholder engagement, procurement, quality standards, continuous improvement, scheduling, pricing and project scope. Even a basic understanding of the complex engineering is also needed.[26]

In our FYDP, we realized the necessity of project management skills for engineering project management to make a successful project which will meet all the relevant criteria. We gathered a basic understanding of engineering project management to manage our project better. Our team showed excellent collaboration and a strong commitment to the project from the beginning. We ensured the use of high-quality materials and conducted a risk assessment to

maintain the project's standards. We also make our project a reasonable project in terms of costs. In one year duration of the FYDP, we developed a comprehensive plan and maintained patience throughout the project's timeline. It was started on June 2nd, 2022 and on May 10th, 2023 it has come to an end.

### 7.2.2: Project management in planning and proposal preparing phase (FYDP – P):

#### Flow diagram



**Figure 54:** Workflow diagram of FYDP P

To start our Final Year Design Project, we brainstormed to find a complex engineering problem related to load shedding and high electricity bills caused by increased government tariffs. By the help of stakeholder interviews, we identified the problem and conducted a literature review to determine hybrid energy system's specifications. Then, we established project objectives and proposed three design approaches based on Hybrid Energy Generation System. Then, we progressed to the design specification phase, created multiple block diagrams and considered constraints while proposing solutions. Additionally, we calculated the overall budget, assessed sustainability and ensured compliance with relevant standards and ethical considerations. Throughout the semester, our ATC panel provided us guidance and advice. We recognized the

problem statement as a complex engineering problem and took risk management and safety measures into account.

Our journey for the Final Year Design Project began with the search for a complex engineering problem that could be addressed with innovative and improvised engineering techniques. We explored multiple problems and reviewed existing solutions, assessing their shortcomings. Eventually, we identified load sharing between hybrid sources as our complex engineering problem and formulated an appropriate problem statement. Subsequently, we identified the requirements and specifications for the project and proposed three distinct design approaches, each with its own prospects and challenges. Finally, we calculated the budget required for implementing each design approach, while also considering the associated risks, safety, and sustainability aspects. As a result, our FYDP journey was successfully concluded.

### Gantt Chart for Phase 01:

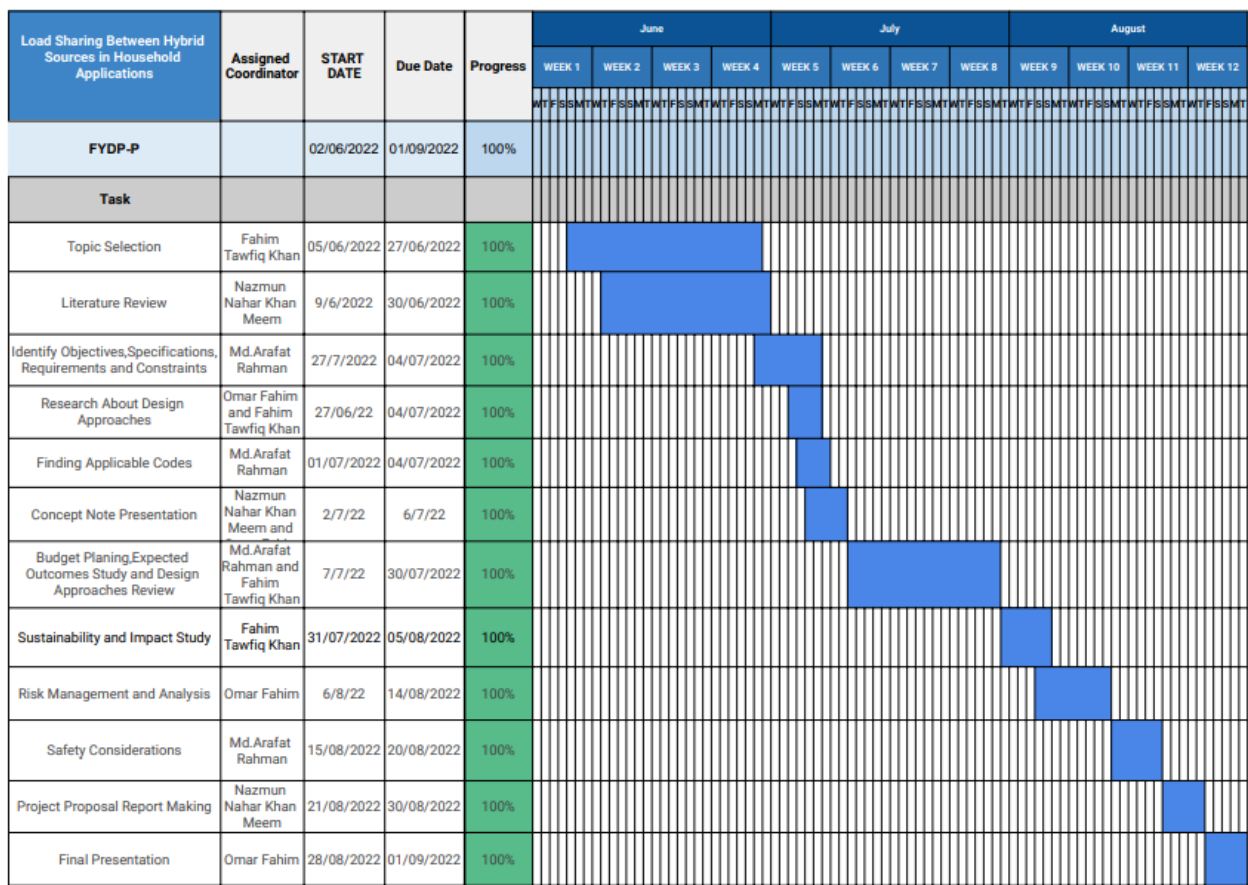


Figure 55: Project plan of FYDP-C

### 7.2.3: Project management in design and development phase (FYDP – D):

#### Flow diagram

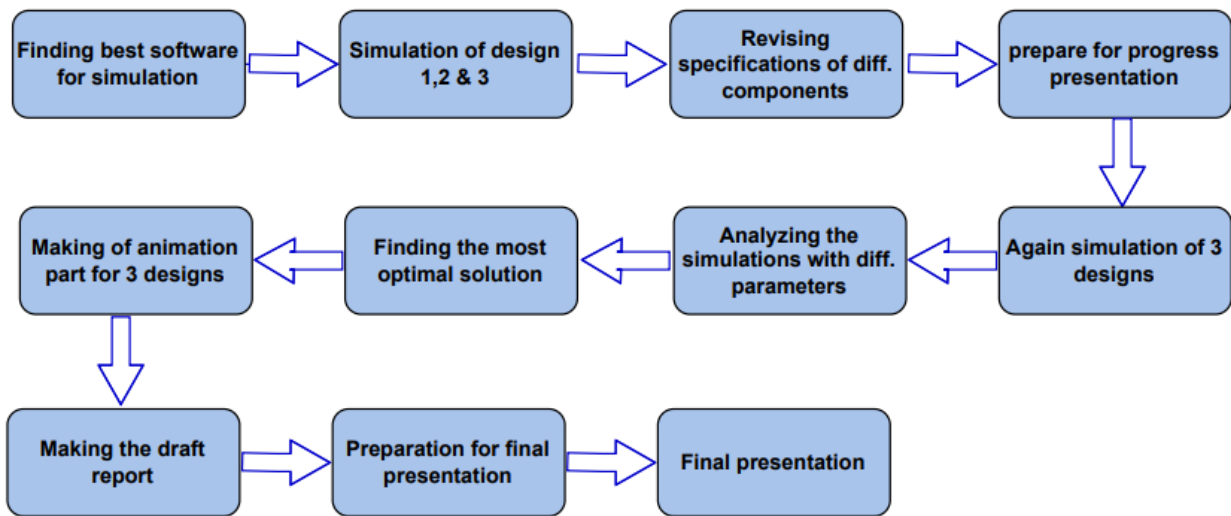


Figure 56: Workflow diagram of FYDP D

Our Final Year Design Project (FYDP) is split into three phases: FYDP-P, FYDP-D, and FYDP-C. This text refers to the FYDP-D phase. During this phase, our primary challenge was to simulate all three design approaches using software like MATLAB Simulink, HOMER and Any logic. We faced some difficulties when we were trying to simulate our designs by using Proteus and we had to consult with our ATC panel to make some necessary changes. Then, we successfully simulated our designs using MATLAB Simulink and moved forward with progress presentations. We initially simulated all three designs and faced some technical problems. After that we made necessary changes with the guidance from our teachers and re-simulated Design Approach 03 based on feedback from our ATC panel. We used Homer Pro software for optimization and considered important parameters such as load sharing, cost, state of charge (SOC) and battery discharge, battery cost efficiency, safety and sustainability when selecting our best design approach. Finally, we chose Design Approach 0 as our best design. This design approach has load sharing between a solar charged battery and the main grid. Then, we worked to address all the Course Outcomes of FYDP-D and prepared ourselves for our mock presentation and final presentation to the ATC panel. Finally, we presented our final simulation of our design and submitted our final report to our ATC panel.



### Gantt Chart for Design Phase:

| Load Sharing Between Hybrid Sources in Household Applications | Assigned Coordinator    | START DATE | Due Date   | Progress | October |        |        |        | November |        |        |        | December |         |         |         |   |
|---|-------------------------|------------|------------|----------|---------|--------|--------|--------|----------|--------|--------|--------|----------|---------|---------|---------|---|
|   |                         |            |            |          | WEEK 1  | WEEK 2 | WEEK 3 | WEEK 4 | WEEK 5   | WEEK 6 | WEEK 7 | WEEK 8 | WEEK 9   | WEEK 10 | WEEK 11 | WEEK 12 |   |
|   |                         |            |            |          | S       | M      | T      | F      | S        | M      | T      | F      | S        | M       | T       | F       | S |
| FYDP-D  |                         | 18/10/2022 | 20/12/2022 | 0        |         |        |        |        |          |        |        |        |          |         |         |         |   |
| Task  |                         |            |            |          |         |        |        |        |          |        |        |        |          |         |         |         |   |
| Simulation of Design Approach 01                              | Fahim Tawfiq Khan       | 28/09/2022 | 20/10/22   | 100      |         |        |        |        |          |        |        |        |          |         |         |         |   |
| Simulation of Design Approach 02                              | Nazmun Nahar Khan       | 01/10/22   | 22/10/22   | 100      |         |        |        |        |          |        |        |        |          |         |         |         |   |
| Simulation of Design Approach 03                              | Nazmun Nahar Khan       | 10/10/22   | 20/11/2022 | 100      |         |        |        |        |          |        |        |        |          |         |         |         |   |
| Preparation For Progress Presentation.                        | Omar Fahim, Md. Arafat  | 21/10/2022 | 27/10/22   | 100      |         |        |        |        |          |        |        |        |          |         |         |         |   |
| Simulation Analysis   | Fahim Tawfiq Khan       | 27/11/22   | 15/12/2022 | 100      |         |        |        |        |          |        |        |        |          |         |         |         |   |
| Develop and Validate The Solution Using Appropriate Tools.    | Md.Arafat Rahman, Fahim | 15/12/2022 | 20/12/2022 | 100      |         |        |        |        |          |        |        |        |          |         |         |         |   |
| Making Animation of Design Approaches.                        | Md.Arafat Rahman        | 27/11/2022 | 15/12/2022 | 100      |         |        |        |        |          |        |        |        |          |         |         |         |   |
| Draft of Report   | Omar Fahim              | 10/12/22   | 22/12/22   | 100      |         |        |        |        |          |        |        |        |          |         |         |         |   |
| Preparation For Final and Mock Presentation                   | Omar Fahim              | 10/12/2022 | 18/12/2022 | 100      |         |        |        |        |          |        |        |        |          |         |         |         |   |
| Final Presentation  | Md.Arafat Rahman        | 19/12/2022 | 22/12/2022 | 100      |         |        |        |        |          |        |        |        |          |         |         |         |   |

Figure 57: Project plan of FYDP-D

### 7.2.4: Project management in completion and execution phase (FYDP – C):

#### Flow diagram

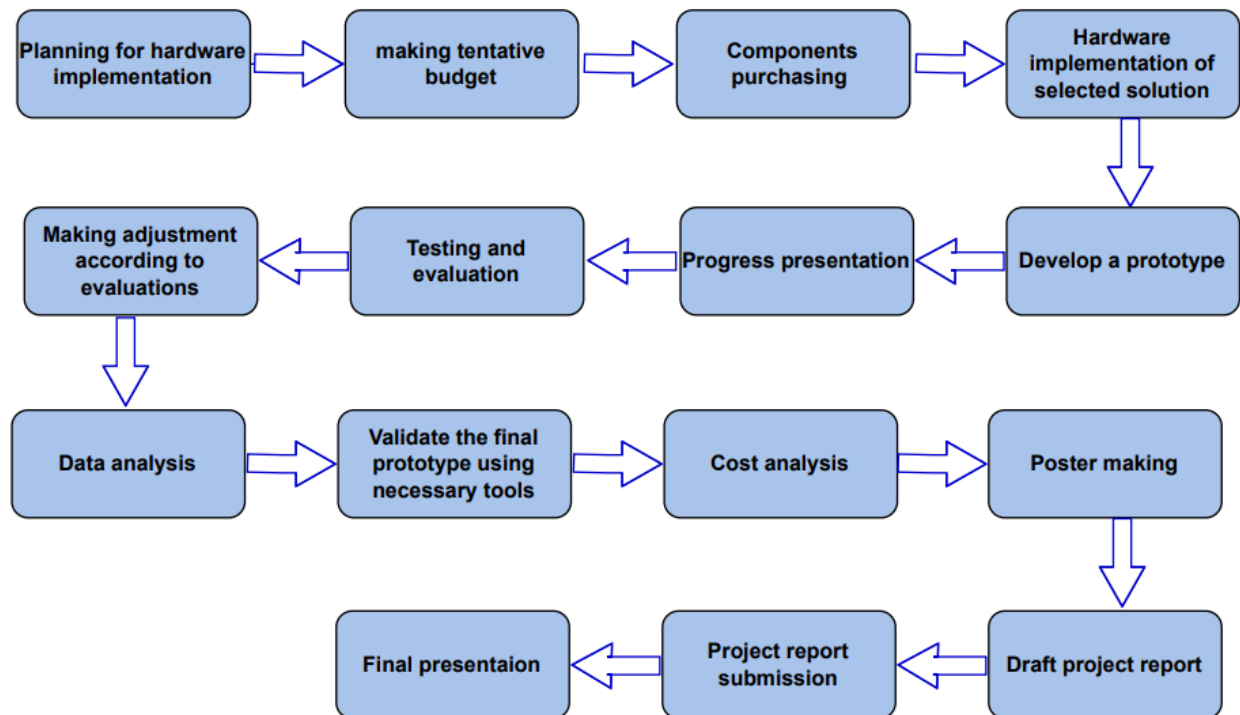


Figure 58: Workflow diagram of FYDP C



### **7.3: Evaluate project progress:**

We made progress in our project by maintaining a regular communication via group discussions, attending meetings with our ATC panel and following a Gantt chart for each phase. During these steps, we addressed a lot of issues and tracked each member's progress. We also had regular meetings with our ATC panel to keep them update about our progress. When we were facing difficulties, we seek guidance from them. They helped us to ensure the validity of our project by evaluating our approaches. Throughout the project, we aimed to maintain the efficiency of our Gantt charts. These gantt charts were developed before the start of each phase. Our Final Year Design Project (FYDP) has three phases. In the FYDP-D phase, we simulated three design approaches by using MATLAB Simulink, HOMER and Any-logic software. Our team faced some challenges and we encountered those challenges when we were simulating designs with Proteus and then we made necessary changes with the guidance from our teachers. Eventually, we selected Design Approach 01. This design approach has a principle of load sharing between a solar-charged battery and the main grid, based on cost, load sharing, state of charge (SOC) and discharging of battery, battery cost efficiency, safety and sustainability parameters. During the FYDP-C phase, we have completed the hardware implementation process. It was included planning and budgeting. Creating a components list, testing and evaluating the prototype are also included in this phase. Then, we submitted a draft project report and poster. Our project's success was dependent on our uniform working approach and the guidance we received from our ATC panel.

### **7.4: Conclusion:**

In conclusion, engineering project management is a very crucial process. It requires effective management skills to ensure successful project completion. We highlighted the use of efficient project management practices which was very necessary in the Final Year Design Project (FYDP). FYDP has three phases and they are; problem definition, project planning and project management. The FYDP project started with the identification of a complex engineering problem. Then, it was followed by the proposal of design approaches. These design approaches were simulated by using various software. Then, the best design approach was selected. After that, we made hardware implementation. Throughout the project, our ATC panel provided us valuable guidance and feedback. These guidance and feedbacks were proved as essential contribution to the successful completion of the FYDP project. Overall, we can say that effective project management skills are very crucial for engineering projects and a detailed plan must be needed for a successful project completion.

## Chapter 8: Economical Analysis. [CO12]

### 8.1 Introduction:

We have chosen a Hybrid energy system for our FYDP. Hybrid energy systems have become a popular energy system as a durable alternative of traditional energy sources.[27] Conducting an economic analysis is very important for any project to determine its feasibility and sustainability in the long run. Our project is not a different case. The economic analysis involves assessing the costs and benefits of hybrid energy systems, identifying potential financial risks and rewards and making sure that resources are used efficiently.[28] The analysis plays a critical role in decision making for investors, policymakers and project managers. Because, it ensures that a country and its citizens derive tangible benefits. We examine the economic analysis of hybrid energy systems, with a focus on their advantages, disadvantages and potential risks. It will help project managers and stakeholders make informed decisions. Ultimately, this process guarantees efficient resource allocation and maximizes the project's value for all.

### 8.2 Economic analysis:

#### Budget for prototype system:

TABLE 10: Budget for prototype system

| Equipment                 | Price (BDT)  |
|---------------------------|--------------|
| 10W 18V Solar panel       | 2050         |
| 9 Ah 12V battery x2       | 750x2 = 1500 |
| DC-AC Inverter x2         | 750x2 = 1500 |
| Solar charge controller   | 300          |
| Structure                 | 1000         |
| Automatic Transfer Switch | 1200         |
| Wiring                    | 800          |

|                       |      |
|-----------------------|------|
| Installation & Others | 1000 |
| Total = 9350 BDT      |      |

This table provides a breakdown of the equipment required to set up a prototype of a solar power system with a hybrid load-sharing feature. The total cost of the equipment comes to 9350 BDT. The system includes a 10W 18V solar panel, two 9Ah 12V batteries, two DC-AC inverters, a solar charge controller, a structure to support the solar panel, an automatic transfer switch and wiring. The installation cost and other expenses are also included in the total cost. With the increasing demand of renewable energy sources and the decreasing cost of solar equipment, it is clear that investing in a solar power system with a hybrid load sharing feature can be a very cost effective and environment friendly alternative of traditional energy sources.

### Budget for real system:

TABLE 11: Budget for real system

| Equipment                 | Price (BDT)      |
|---------------------------|------------------|
| 300W 12V Solar panel      | 16,500           |
| 12V 150 Ah battery x2     | 28,000x2 = 56000 |
| Inverter (300W 12V) x2    | 6,500x2 = 13,000 |
| Automatic transfer switch | 1200             |
| Solar charge controller   | 800              |
| Structure                 | 3,000            |
| Wiring                    | 2,000            |
| DC Cable & AC Cable       | 3,000            |

|                       |       |
|-----------------------|-------|
| Installation & Others | 3,500 |
| Total = 99,000 BDT    |       |

From this table, we can see the budget for a real system includes a 300W 12V solar panel, two 12V 150Ah batteries, two 300W 12V inverters, an automatic transfer switch, a solar charge controller, a structure, wiring, DC cable and AC cable, and installation costs. The total cost of the system is 99,000 BDT. This system is more powerful than the previous one with a higher capacity solar panel and larger batteries. It is suitable for powering more appliances or for longer periods of time. Proper installation and maintenance of the system will ensure that it functions optimally and provides reliable and sustainable energy.

### 8.3 Cost benefit analysis:

To conduct a cost benefit analysis on any hybrid energy system must be measured and assigned a monetary value. The analysis needs determining the system's lifespan, capacity, efficiency, and energy output. The costs of installation, operation and maintenance should be evaluated. Not only that but also, we have to keep in mind that the financing of that project and fuel expenses. The benefits of a hybrid energy system, such as reduced carbon emissions, avoided fuel costs and energy security, must also be quantified and given a monetary value. Environmental damage costs associated with traditional energy sources may also be considered as a benefit of a hybrid energy system.

Once all costs and benefits have been measured then they can be compared to make decision whether the hybrid energy system is financially feasible or not. If the benefits exceed the costs, the system can be awarded as a worthy investment. On the other hand, if the costs exceed the benefits, the system may not be a field of good investment. A cost benefit analysis of a hybrid energy system requires the quantification and comparison of potential costs and benefits. This process is critical for determining the economic viability of the system and ensuring the efficient allocation of resources.

For cost benefit analysis of our project, we conducted a evaluation of cost comparison. Here it is:

TABLE 12: Cost comparison

| <b>Customer No</b>                     | Customer 01         | Customer 02  | Customer 03  |
|--|---------------------|--|--|
| <b>Source Type</b>                     | Conventional Source | Solar Energy   | Hybrid System<br>(Our Project)                                 |
| <b>Required Load<br/>(Per Year)</b>    | 3840 kWh (Avg)      | 3840 kWh (Avg)   | 3840 kWh (Avg)   |
| <b>Unmet Load<br/>(Per Year)</b>       | 0 kWh               | 1500 kWh   | 0 kWh  |
| <b>Electricity Bill</b>                | 28185.6 TK          | 0 TK   | 11010 TK   |
| <b>Bill Saved<br/>(Per Year)</b>       | 0 TK                | 17175.6 TK   | 17175.6 TK   |
| <b>Maintenance Cost<br/>(Per Year)</b> | 1440 TK             | 2000 TK  | 2200 TK  |
| <b>Installation Cost</b>               | 5000 TK             | 85000 TK   | 99000 TK   |
| <b>Return Of Investment<br/>(ROI)</b>  | No ROI              | After 5 years free<br>electricity but some<br>unmet electricity. | After 6 years free<br>electricity with no unmet<br>electricity |

In this project, we performed a cost benefit analysis of three energy systems: a conventional source, a renewable energy system and our hybrid energy system. The targeted customers are general individuals, as the systems are designed for household applications. We analyzed three systems based on customer feedback where each customer is using a different system. We compared the cost benefits of the three systems based on six parameters. They are unmet load, electricity bill, bill saved, maintenance cost, installation cost and return on investment (ROI) per year. In each scenario, the required load was same and it is 3840 kWh per year. We found that our hybrid energy system had no unmet energy, while the conventional energy system had no unmet energy too but with emission of harmful gass. And the renewable energy system had 1500 kWh of unmet energy. The electricity bill of our hybrid energy system was 11010 tk per year, while the conventional energy system's bill was 28185.6 tk per year and the renewable

energy system was free. We found that both the renewable energy system and our hybrid energy system had the same amount of savings, which was 17175.5 tk per year. The maintenance cost of our hybrid energy system is 2200 tk per year. On the other hand, the conventional and renewable energy systems maintenance cost is 1440 tk and 2000 tk, respectively. The installation cost of our hybrid energy system is 99000 tk but the conventional energy system's installation cost is 5000 tk and the renewable energy system's installation cost is 85000 tk. Finally, we evaluated the ROI for the three systems. From our evaluation, we find that the conventional energy system had no ROI. On the other hand, the renewable energy system's customer will get their investment back within 5 years with some unmet energy and our hybrid energy system's customer will get their initial investment back within 6 years with no unmet energy. So, based on this explanation we can say that our project is much better one among the available projects in the market.

#### **8.4 Evaluate economic and financial aspects:**

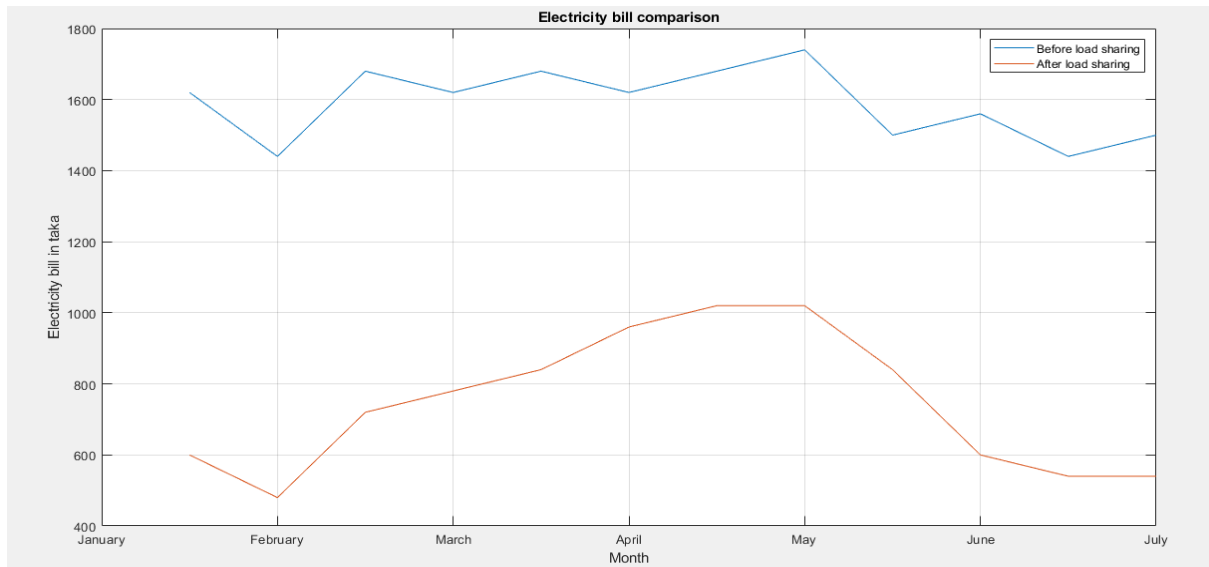
Bangladesh imports a significant amount of fossil fuels from other countries for the growing demand of electricity.[29] The resulting rise in gas prices can make a unrest situation within society. The government has spent a lot of foreign reserves to export fossil fuels. However, implementation of our project could help the government to save money by providing a stable source of electricity to households, reducing the need for extra energy generation and rental power plants, which are costly. The government can use this savings to improve the country's infrastructure. Eventually, this will create more business opportunities and jobs. As a result, these things will lead us to a prosperous economy.

Conservation of natural resources is also a major concern. By relying more on renewable energy sources, we can rise our living standards without increasing gasoline prices. By using our project, we can save electricity and it will allow us to use those saved electricity in other important projects. As a result, the citizens and the government can save money. This could lead to a better quality of life for the citizens, as they can spend the money on education and improving their lifestyle. Furthermore, a stable electricity system can lead to an increased participation in social, cultural and fun activities. Eventually, this will lead them to a fresh mind. As a result, it will increase efficiency at work and it will be beneficial for the national economy.

Furthermore, we tried to come up with some prove also. In chapter 02, we used homer for selecting the optimized design. From there, we got some comparison between hybrid energy system and the conventional energy system from economic and financial perspective. Here we highlighted some of them.



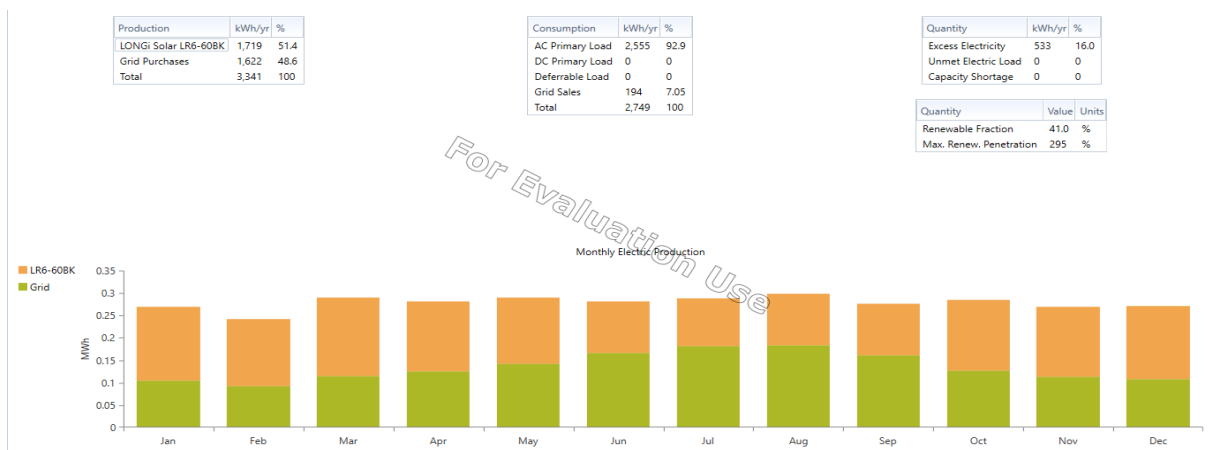
## Electricity Bill comparison:



**Figure 60:** Electricity bill comparison

We got an electricity bill comparison between a hybrid energy system (our project) and conventional energy system. From the graph, we can see that the hybrid system has less electricity bill from the conventional energy system. From that graph, it is clear that the hybrid energy system is much better than the conventional energy system for the customers from an economic perspective.

## Load Sharing Comparison:



**Figure 61:** Load sharing between conventional grid and solar panels

Here, a large amount of load is shared from solar energy. More specifically, 48.6% energy is shared from grid energy and 51.4% energy is shared from solar. So that dependency on grid energy is decreased significantly. That means, we can save more than 51% fossil fuels who are

using for electricity generation for conventional energy system. As a result, government can save those money and can spend those money for the country's infrastructure development or other sectors. So, hybrid energy system is definitely a beneficial project from economic point of view.

**Cost comparison:**

|                 |              |
|-----------------|--------------|
| NPC ⓘ           | \$1,832      |
| Initial Capital | \$504.96     |
| O&M ⓘ           | \$102.69/yr  |
| LCOE ⓘ          | \$0.0513/kWh |

**Figure 62:** Cost of Design 1

|                 |              |
|-----------------|--------------|
| NPC ⓘ           | \$1,982      |
| Initial Capital | \$0.00       |
| O&M ⓘ           | \$153.30/yr  |
| LCOE ⓘ          | \$0.0600/kWh |

**Figure 63:** Cost of conventional grid energy

From the above comparison, it is clear that the Operating and Management (O&M) cost of Design 01 is lower than that of the grid. Here design 01 is our project. Additionally, the Levelized Cost of Energy (LCOE) is also lower in Design 01. This makes our project a cost-effective design in compares to conventional energy system. Furthermore, the net present cost for Design 01 is also lower than conventional grid energy. Therefore, it is proved that the project is financially beneficial than existing conventional energy system.

**8.5 Conclusion:**

In conclusion, the economic analysis of the hybrid energy system in the FYDP project shows that it can be a feasible and sustainable alternative of conventional energy sources. The analysis is presenting the costs of setting up both prototype and real systems and the operating and maintenance cost. The cost-benefit analysis tells that the hybrid energy system is offering benefits such as reduced greenhouse gas emissions, improved energy security and lower operating costs. However, it also has the initial capital investment. It also has a transitioning cost of transformed into the hybrid energy system from a traditional energy system. More advantages of the hybrid energy system is avoiding fuel costs and it must be counted and given a monetary value. If the benefits outweigh the costs, the system can be considered a worthy investment. Overall, the economic analysis of the hybrid energy system provides us a valuable insight for investors, policymakers and project managers to work on project's favor to extract its maximum output.

## Chapter 9: Ethics and Professional Responsibilities CO13, CO2

### 9.1: Introduction

As we move towards a more sustainable future, renewable energy sources such as solar energy are becoming increasingly important. However, implementing such projects requires not only technical expertise but also ethical considerations and professional responsibility. In this context, we will explore the ethical issues and professional responsibility that arise when implementing a solar panel project on a residential building rooftop. We will discuss the need for stakeholder permission, ensuring the confidentiality of personal information, and the importance of fairness in selecting the best design. By examining these issues, we can ensure that our project not only benefits the environment but also adheres to ethical principles and professional responsibility.

### 9.2: Identify ethical issues and professional responsibility

The project we are going to implement requires a lot of space as solar panels need to be installed in the project area. Our preferable site for installation is on the rooftop since the area is often left unused and we can utilize the free space by installing solar panels. However, the rooftop area has many other utilities as well. Therefore, we need permission from all the stakeholders which means all the residents of the apartment should approve our plan. Also, we have to design our system in a suitable way so that a significant portion of the rooftop area remains usable for other activities. Moreover, the installation site should be easily accessible so that maintenance duties can be performed properly.

The next concern regarding our project is installing battery and power electronics components. Additionally, we will have separate supply lines connecting the installation area with the households. For all these installations, we need permission from the building owner or from the building management committee.

Finally, we will have to inform our stakeholders about the risks and hazards of the project to maintain transparency. We have to make sure that the stakeholders are aware of each and every aspect of the system and we have their full consent to this project.

### **9.3: Apply ethical issues and professional responsibility**

#### **9.3.1: The research method used for designing:**

The goal of our project is load sharing with hybrid sources. We had to design a system that would meet our goal. For that we had to go through a lot of research, so that we can come up with a very good design. To do that we carefully examined the available research and followed all relevant IEEE standards and directives to make sure that our project's goal does not compromise and we had to make sure that there are therefore no risks associated with the research approach.

#### **9.3.2: Confidentiality:**

We generally know that personal documents are confidential but we need some documents and data so that we can design our project accordingly. For that, we had to make sure that the information of our stakeholders will not be disclosed and then we got some data from our stakeholders. As our main stakeholders are the general people, we need to talk with them in different phases of our project. But we are bound to keep confidentiality of all information provided by them. We won't share or give access to any information related to them or provided by them under any circumstances. Further, we will keep the anonymity of the participants too.

#### **9.3.3: Fairness in picking up the best design:**

We gave our best effort to choose the most optimum design for our targeted stakeholders. We did not intend to go for the design which was easy to build. Rather, our concern was to provide such a design which will be sustainable in terms of all relevant criteria. We went for possible best outcomes for our stakeholders as our responsibility is to give them the best. So, we did our best to make sure that the best design will go further. We made a crystal-clear decision for this.

#### **9.3.4: Professional Responsibilities:**

As an engineer we have some responsibilities to make a project without risk. Addition to that, we have to make a user-friendly system so that our consumers can use the system without any hazard. Moreover, we have to make sure that we are updating our system according to our consumer's demand.

## **Risk identification and management:**

### **Risks from battery:**

Large-capacity rechargeable batteries made of lead acid are rather prevalent. They are employed in autos, watercraft, electric vehicles, and uninterruptible power sources (UPS). The constituent cells that make up these batteries each have layers of lead alloy plates that are submerged in an electrolyte solution. Lead is frequently mixed with trace amounts of other metals, such as antimony, calcium, tin, and selenium, to increase its mechanical strength and improve its electrical qualities. Energy is created when the sulfuric acid comes into contact with the lead plate and triggers a chemical reaction. The electrolyte solution is typically made up of 35% sulfuric acid and 65% water.[17]

The hazards associated with the batteries include chemical, fire or explosion, electrical shock, and ergonomics. These hazards are described further below:

- **Chemical Hazards:** Lead acid batteries include sulfuric acid, a very corrosive substance, in their electrolyte solution. It can harm the eyes in addition to causing serious chemical burns to the skin. If consumed, the solution is also poisonous. In addition, a lead acid battery that has been overcharged may release hydrogen sulfide gas. This gas smells like rotten eggs or natural gas and is colorless, lethal, and combustible. Because the gas is heavier than air, it will collect at the bottom of spaces with poor ventilation.[16]
- **Fire/explosion:** While being discharged, lead acid batteries release little to no gas, but when they are being charged, especially vented lead acid (VLA) batteries, explosive combinations of hydrogen and oxygen can be created. In contrast to oxygen, which is an oxidizer that can cause a fire or explosion, hydrogen gas is colorless, odorless, lighter than air, and highly flammable. Hydrogen gas may gather towards the ceiling and provide a fire or explosion hazard if vented lead acid (VLA) batteries are charged in a closed space with inadequate ventilation.[16]
- **Electrical shock hazards:** Batteries can contain a significant amount of stored energy, and some battery systems can discharge at high rates of current. Exposed battery terminals can be a shock hazard even for disconnected batteries. Using too little of a load can short out the terminals or wires, which can result in severe electrical arcing that can shock or burn nearby individuals.[17]
- **Ergonomic hazards:** Large in size and high lead content make lead acid batteries hefty. The typical weight 39 pounds is the weight of a typical vehicle battery, while other lead acid batteries can weigh substantially more. These big weights make injuries from improper lifting, handling, or transportation possible.[16]

### **Things To Do:**

- Lead acid batteries should only be charged in well-ventilated spaces, preferably under fume hoods or below a snorkel.
- Use caution when handling any batteries or battery-operated equipment to avoid damaging the connections or casings.
- Provide physical isolation between batteries and flammable items, water, seawater, powerful oxidizers, and acids.
- Before using a battery, check it for symptoms of damage. Never use a battery that looks distorted, swollen, or broken.
- Do not leave batteries in direct sunlight, on hot surfaces, or in hot locations.
- Allow the battery to cool before using after charging and before charging after using.
- Use proper ergonomic techniques when lifting or moving lead acid batteries.

### **Risks From Electrical Equipment:**

The hazards arising from the use of electrical equipment are:

- **Electric shock:** Shock by direct or indirect contact with a live or charged conductor. It can be very risky.
- **Electric burn:** Burns caused by coming into contact with or being close to a live or charged conductor, or by being exposed to an arc or high-energy discharge.[19]
- **Fires and explosions:** Fires and explosions brought on by electrically igniting combustible materials and chemicals, as well as explosions brought on by the failure of equipment exposed to excessive or significant fault currents.
- **Interruption to essential services:** Interruption to essential safety equipment by loss of electrical power.[18]

### **Things To Do:**

- Using proper insulation.
- Automatic disconnection by fuses and circuit breakers - preventing overheating by excess current.[19]
- Enough socket outlets to minimize the need for several adaptors or lengthy cords.
- Protection from shock or high leakage currents caused by entry or splashing of liquids or particles by location or enclosure.
- Explosion-protected gear in flammable, explosive environments - avoiding flames and explosions.
- Proper earthing and circuit breakers should be used.[18]

**Risk From Solar Panel:**

- The panels can get hot (from the sun) with a (minor) risk of burns.
- There is a risk that solar panel or glass of the panels may break.
- It is also possible that arrays which are stood off from the roof may cause a channeling effect, thus exacerbating a fire affecting the roof.[20]

**Things To Do:**

We should use a proper frame to protect solar panels and we should maintain solar panels more often.

**Over Current Flow:**

Many incidents like important loads demand connection to the grid, lightning strikes, faulty wires and devices or even circuits can cause the network to experience voltage drop for a short time. These things can lead the system towards over current flow or high penetration of current. As a result, a serious situation can arise.[21]

**Things To Do:**

We should use a proper circuit breaker so that the line can get disconnected when these situations occur.

**Risk matrix:**

TABLE 13: Quantitative analysis of Risk matrix.

| Likelihood & Consequences |          |          |        |                |              |   |
|---------------------------|----------|----------|--------|----------------|--------------|---|
| 1                         | 2        | 3        | 4      | 5              |              |   |
| Rare                      | Unlikely | Possible | Likely | Almost certain |              |   |
| 4                         | 8        | 12       | 16     | 20             | Catastrophic | 4 |
| 3                         | 6        | 9        | 12     | 15             | Major        | 3 |
| 2                         | 4        | 6        | 8      | 10             | Moderate     | 2 |
| 1                         | 2        | 3        | 4      | 5              | Minor        | 1 |

**Risks:**





- Low = 1-5 
- Moderate = 6-10 
- High = 11-15 
- Extreme = 16-20 



TABLE 14: Risk management overview

| <b>Risk Identification</b>     | <b>Description</b>   | <b>Likelihood</b> | <b>Consequence</b> | <b>Risk Factor</b> | <b>Contingency Plan</b>                                      |
|--------------------------------|--|-------------------|--------------------|--------------------|--|
| Risk from battery              | Chemical Hazard  | Unlikely          | Major              | Moderate (6)       | Use proper PPE   |
|                                | Fire/Explosion   | Unlikely          | Major              | Moderate (6)       | Handle with care.  |
|                                | Electric Shock   | Unlikely          | Major              | Moderate (6)       | Use proper cover.  |
|                                | Ergonomic Hazard   | Unlikely          | Minor              | Low (2)            | Self-awareness.  |
| Risk from electrical equipment | Electric Shock   | Unlikely          | Major              | Moderate (6)       | Self-awareness   |
|                                | Electrical Burn  | Unlikely          | Major              | Moderate (6)       | Use of PPE and self-awareness.                               |
|                                | Fires and Explosion  | Unlikely          | Major              | Moderate (6)       | Use of high-quality electrical equipment and wiring.         |
|                                | Interruption to essential services.                          | Likely            | Minor              | Low (4)            | Regular maintenance.   |
| Risk from Solar panel          | Over Heating   | Likely            | Minor              | Low (4)            | Regular maintenance.   |
|                                | Panel Breaks   | Unlikely          | Minor              | Low (2)            | Need to install a high-quality frame.                        |
|                                | Channeling Effect  | Unlikely          | Minor              | Low (2)            | Regular maintenance.   |
| Risk from current over-flow    | Lightning strikes, faulty wires and devices, short circuits. | Likely            | Major              | High (12)          | Use high quality devices and wiring and regular maintenance. |
|                                | Electrical Failure   | Likely            | Minor              | Low (04)           | Regular inspection and maintenance.                          |
|                                | Mechanical Failure.  | Unlikely          | Minor              | Low (02)           | Proper management.   |

|                               |                                     |          |       |               |   |
|-------------------------------|-------------------------------------|----------|-------|---------------|---|
| Risks from wind turbines      | Wind Turbine Failure.               | Unlikely | Major | Moderate (06) | <ol style="list-style-type: none"> <li>1. Regular inspection.</li> <li>2. Proper maintenance.</li> <li>3. Shutting down the system during bad weather like storm and lightning.</li> </ol>  |
| Risks from hydrogen fuel cell | Highly flammable and invisible gas. | Unlikely | Major | Moderate (06) | <ol style="list-style-type: none"> <li>1. Using proper protective equipment.</li> <li>2. Removing all flammable things from the site.</li> <li>3. Working with proper knowledge.</li> </ol> |

#### 9.4: Conclusion:

In summary, the project involves ethical considerations and professional responsibilities such as obtaining permission from all stakeholders, designing the system in a suitable way to ensure the rooftop area remains usable for other activities, informing stakeholders of risks and hazards, following IEEE standards and directives in research methodology, maintaining confidentiality of stakeholder information, and ensuring fairness in choosing the best design. These considerations demonstrate the importance of conducting projects in an ethical and responsible manner, with the welfare of stakeholders at the forefront

## Chapter 10: Conclusion and Future Work.

### 10.1: Project summary/conclusion:

The title of our project is Load sharing Between Hybrid Sources in Household Applications. In our project we have developed a load sharing mechanism which is controlled by an automatic transfer switch (ATS) system. Basically, this project is based on solar energy and conventional grid energy. To develop the project firstly we have made an auto transfer switch (ATS) which is able to switch the energy sources according to the state of charge (SOC) of the battery. By checking the battery SOC, the sources will be shifted alternately. Additionally, we have another battery as a backup source for our project. Moreover, an extra load is connected with a push switch, when we press that switch our system starts to take the energy from that backup source. To sum up, our project works upon the data of state of charge (SOC) of the battery and adding an extra load which is consumed from an additional power source is justifying the load sharing mechanism.

### 10.2: Future work:

We are working with solar energy and conventional grid energy in our project. In our project we have faced battery voltage fluctuating issue a lot. To prevent the problem, we can use modern microcontroller like PLC's. Moreover, PLC can provide a reliable system with high safety. Moreover, in case of an autonomous dead situation we can incorporate a generator as a backup. When we will be running out of solar energy along with conventional grid energy, we can use that generator as a backup energy source in our system to make the system more sustainable. To sum up, we can incorporate a modern microcontroller to enhance the controlling system and we can have a additional power source as a backup in any autonomous dead situation.

## Chapter 11: Identification of Complex Engineering Problems and Activities.

### 11.1: Identify the attribute of complex engineering problem (EP)

#### Attributes of Complex Engineering Problems (EP)

|    | Attributes                                  | Put tick (√) as appropriate |
|----|---|-----------------------------|
| P1 | Depth of knowledge required                 | √                           |
| P2 | Range of conflicting requirements           |                             |
| P3 | Depth of analysis required                  | √                           |
| P4 | Familiarity of issues                       | √                           |
| P5 | Extent of applicable codes                  |                             |
| P6 | Extent of stakeholder involvement and needs |                             |
| P7 | Interdependence                             | √                           |

Note: Must have P1, and some or all from P2-P7

### 11.2: Provide reasoning how the project address selected attribute (EP):

#### P1: Depth of knowledge required:

We started this project with a vision of sharing load in households with hybrid sources. We have some objectives to full-fill in this project. To full-fill those we need knowledge about hybrid systems and load sharing. In addition, we need to understand the optimal controlling system between sources. Furthermore, to develop an Automatic Transfer Switch (ATS) we need to understand the relay operations along with transistors and resistors-capacitors. Moreover, knowledge about sustainability, cost, efficiency and usability of our selected design is required.

#### P3: Depth of analysis required:

We go through some publications, journals, and simulation software to gather information about effective design and control ideas, safety & security, risk, and health issues. On the basis of that, we approach 3 different designs for our project. Then we select the most effective controlling system. After completing optimization for different factors, for example amount of load sharing energy from hybrid sources, charging and discharging rate of battery, cost and others, we select the best solution for load sharing. Again, after lots of analysis regarding load

calculations we select appropriate micro-controller and other suitable components for this project.

**P4. Familiarity of issues:**

Nowadays using renewable energy sources besides grid energy sources is a familiar issue. Among all the renewable energy, the most commonly used renewable energy is solar energy. We all more or less notice solar panels at the rooftop of one storey building, shopping mall, industry, apartment both in cities and villages. In our project we are dealing with hybrid sources for load sharing where solar energy is used to support household loads along with grid energy.

**P7. Interdependence:**

Interdependence in a project means a connection between activities of members which can influence another’s progress and can drastically change the overall project’s progress. Dependencies of our project can be defined as tasks, technologies, procedures or resources. Every part of our project is reasonably interdependent with each-other.

**11.3 Identify the attribute of complex engineering activities (EA):**

**Attributes of Complex Engineering Activities (EA)**

|    | <b>Attributes</b>                            | <b>Put tick (√) as appropriate</b> |
|----|--|------------------------------------|
| A1 | Range of resource                            | √                                  |
| A2 | Level of interaction                         |                                    |
| A3 | Innovation                                   |                                    |
| A4 | Consequences for society and the environment | √                                  |
| A5 | Familiarity                                  | √                                  |

Note: Must have some or all of the characteristics from attributes A1 to A5

**A1: Range of resources**

There are numerous resources about load sharing for hybrid sources. We go through different publications, documentaries for detailed knowledge for better understanding about the working procedure of hybrid sources in case of load sharing. In addition, we go through some papers that are working with Automatic Transfer Switch (ATS) to understand the working mechanism of ATS.

#### **A4: Consequences for society and the environment**

We design the controlling system in such a way so that dependency on conventional sources is reduced as much as we can for load sharing purposes. Basically, natural resources are the main source of conventional energy which are responsible for carbon emissions (92%) in the environment. We try to focus on green energy as much as we can in load sharing which will encourage people to reduce carbon emissions, to be environment friendly and to be a green energy user.

#### **A5: Familiarity**

There are numerous people in Bangladesh who use hybrid energy sources for day-to-day life. Some of them are using PV panels, solar IPS and others. We try to combine these renewable sources with the main grid for load sharing under certain controlling mechanisms. In short, it's nothing new, just an optimized controlling system of load sharing for the maximum use of green energy along with the grid.

## References

- [1] S. Hossain and M. Rahman, "Solar Energy Prospects in Bangladesh: Target and Current Status", *Energy and Power Engineering*, vol. 13, no. 08, pp. 322-332, 2021. Available: 10.4236/epe.2021.138022 [Accessed 10 September 2022].
- [2] M. Khan, M. Iqbal and S. Mahboob, "A wind map of Bangladesh", *Renewable Energy*, vol. 29, no. 5, pp. 643-660, 2004. Available: 10.1016/j.renene.2003.10.002 [Accessed 10 September 2022].
- [3] Ndre.sreda.gov.bd. 2022. Wind Projects | National Database of Renewable Energy, SREDA. [online] Available at: <<https://ndre.sreda.gov.bd/index.php?id=1&i=11>> [Accessed 10 September 2022].
- [4] Hossain Lipu, M. S. & Uddin, Md & Miah, Muhammad. (2013). A feasibility study of solar-wind-diesel hybrid system in rural and remote areas of Bangladesh. *International Journal of Renewable Energy Research*. 3. 892-900.
- [5] S. Hossain and M. Rahman, "Solar Energy Prospects in Bangladesh: Target and Current Status", *Energy and Power Engineering*, vol. 13, no. 08, pp. 322-332, 2021. Available: 10.4236/epe.2021.138022 [Accessed 10 September 2022].
- [6] R. L. Fares and M. E. Webber, "The impacts of storing solar energy in the home to reduce reliance on the utility," *Nature News*, 30-Jan-2017.[Online]. Available:<https://www.nature.com/articles/nenergy20171#Tab1>.
- [7] M. B. Roberts, Anna Bruce and Iain MacGill, "Impact of shared battery energy storage systems on photovoltaic self-consumption and electricity bills in apartment buildings," *Applied Energy*, 13-Apr-2019.[Online]. Available:<https://www.sciencedirect.com/science/article/abs/pii/S0306261919306269>.
- [8] I. M. Q. Azeem, Habib-ur-Rehman, S. Ahmed and A. Khattak, "Design and analysis of switching in automatic transfer switch for load transfer," 2016 International Conference on Open Source Systems & Technologies (ICOSST), Lahore, Pakistan, 2016, pp. 129-134, doi: 10.1109/ICOSST.2016.7838589.
- [9] N. A. Siddiquee, S. A. Hossain and S. Banik, "Hybrid Renewable Energy Systems," in *Proceedings of the International Conference on Sustainable Energy and Green Technology 2018 (SEGT 2018)*, Eds. N. A. Siddiquee, R. Saidur, H. H. Masjuki and S. A. Hossain, 2019, pp. 1141-1148. doi: 10.1007/978-981-15-0214-9\_109.
- [10] H. M. Ali, M. R. Hasan, M. N. Uddin, and M. R. Islam, "Design and Simulation of a Hybrid Solar-Wind Energy System for Standalone Applications," *International Journal of Electrical and Computer Engineering Systems*, vol. 12, no. 3, pp. 66-73, 2021. Available: <https://ijeecs.iaescore.com/index.php/IJECS/article/view/20764>.
- [11] Jossi, Frank (11 March 2019). "[Wind-solar pairing cuts equipment costs while ramping up output](#)". *Renewable Energy World*. Energy News Network. [Archived](#) from the original on 18 December 2019.
- [12] "[First Danish Hydrogen Energy Plant Is Operational](#)" [Archived](#) 26 September 2007 at the [Wayback Machine](#) Renew ND. Retrieved 30 October 2007.
- [13] <https://wellthatsinteresting.tech/are-microgrids-the-future/#:~:text=As%20such%20the%20sector%20is,global%20valuation%20of%20%2433%20billion.>

- [14]. <http://www.sreda.gov.bd/>," Sustainable and Renewable Energy Development Authority, [Online]. Available: <http://www.sreda.gov.bd/site/page/55f1b362-a4b9-4586-b670-21c0b1fc7593/>-. [Accessed 15 11 2021]
- [15]. Webstore," [Online]. Available: <https://webstore.iec.ch/publication/26423>. [Accessed 1 12 2021].
- [16] H. Lestari, M. Arentsen, H. Bressers, B. Gunawan, J. Iskandar, and Parikesit, "Sustainability of renewable off-grid technology for Rural Electrification: A Comparative Study using the IAD Framework," MDPI, 30-Nov-2018. [Online]. Available: <https://www.mdpi.com/2071-1050/10/12/4512>. [Accessed: 01-May-2023].
- [17] <https://www.sciencedirect.com/science/article/abs/pii/S1364032118303228> Khalil, M., et al. "The impact of renewable energy systems on human health: a systematic review." International Journal of Environmental Research and Public Health, vol. 17, no. 21, 2020, doi: 10.3390/ijerph17218067.
- [18] <https://www.sciencedirect.com/science/article/abs/pii/S2352152X22006958> M. Kumar, "Social, Economic, and Environmental Impacts of Renewable Energy Resources," 21 01 2020. [Online]. Available: <https://www.intechopen.com/chapters/70874>.
- [19] "A review on the utilization of hybrid renewable energy," Renewable and Sustainable Energy Reviews, 01-Jun-2018. [Online]. Available:<https://www.sciencedirect.com/science/article/abs/pii/S1364032118303228>. [Accessed: 01-May-2023].
- [20] "Renewable energy consumption and health outcomes: Evidence from global ..." [Online]. Available:[https://www.researchgate.net/publication/351256306\\_Renewable\\_Energy\\_Consumption\\_and\\_Health\\_Outcomes\\_Evidence\\_from\\_Global\\_Panel\\_Data\\_Analysis](https://www.researchgate.net/publication/351256306_Renewable_Energy_Consumption_and_Health_Outcomes_Evidence_from_Global_Panel_Data_Analysis). [Accessed: 01-May-2023].
- [21] N. Osseiran, 9 out of 10 people worldwide breathe polluted air, but more countries are taking action,Geneva:WHO,2018.<https://www.who.int/news/item/02-05-2018-9-out-of-10-people-worldwide-breathe-polluted-air-but-more-countries-are-taking-action>.
- [22] "Benefits of Renewable Energy Use," 20 12 2017. [Online]. Available: <https://www.ucsusa.org/resources/benefits-renewable-energy-use>.
- [23] E. a. M. R. Ministry of Power, "GUIDELINES FOR THE IMPLEMENTATION," 10 2013. [Online]. Available: <https://policy.asiapacificenergy.org/node/218>
- [24] OEC," OEC, [Online]. Available:<https://oec.world/en/profile/bilateral-product/refined-petroleum/reporter/bgd>.
- [25] "What is Engineering Project Management? A complete guide." [Online]. Available: <https://www.indeed.com/career-advice/finding-a-job/project-management-engineering>. [Accessed: 01-May-2023].
- [26] "What is Engineering Project Management?," Versatile & Robust Project Management Software. [Online]. Available: <https://www.wrike.com/project-management-guide/faq/what-is-engineering-project-management/>. [Accessed: 01-May-2023].
- [27] "Renewable hybrid energy systems as a game changer in India | McKinsey & Company," [www.mckinsey.com](http://www.mckinsey.com). <https://www.mckinsey.com/capabilities/sustainability/our-insights/sustainability-blog/renewable-hybrid-energy-systems-as-a-game-changer-in-india>
- [28] B. Gupta, M. P. Jaiswal, S. Singh and S. P. Singh, "Prediction of blasting-induced flyrock in opencast mines using ANN and ANFIS," Journal of Loss Prevention in the Process Industries, vol. 30, 2014, pp. 228-237, doi: 10.1016/j.jlp.2014.06.009.



[29] “Oil import for 2023: BPC gets nod to buy 54 lakh tonnes,” *The Daily Star*, Oct. 19, 2022. <https://www.thedailystar.net/environment/natural-resources/energy/news/oil-import-2023-bpc-gets-nod-buy-54-lakh-tonnes-3147261> (accessed May 01, 2023).

## Appendix

### Necessary Codes:

```
#define relay_inv_on_off 5
#define relay_b1_b2 4
#define relay_inv_ac 3
#define relay_load2_ac 2
#define relay_load2_sw 9

#define s_bat1 A2
#define s_bat2 A1

#define threshold_L 9.50
#define threshold_H 12.5

#include <Wire.h>
#include <LiquidCrystal_I2C.h>
LiquidCrystal_I2C lcd(0x27,20,4);

bool stts = 0,btn=1, old_btn=1, load2_stts =0;

float bat1_v = 0, bat2_v = 0;

uint8_t batry1 = 0, batry2 = 0, ac = 0;
uint8_t old_batry1 = 0, old_batry2 = 0;

uint8_t mode = 1, mode2 = 0;
//mode 1: 1--> from battery 1 //2--> from battery 2 //3--> from ac
//mode 2: 0--> OFF //2--> from battery 2 //3--> from ac

void setup() {
  Serial.begin(9600);

  lcd.init(); // initialize the lcd
  lcd.init();
  lcd.backlight();

  pinMode(relay_inv_on_off,OUTPUT);
  pinMode(relay_b1_b2,OUTPUT);
```

```

pinMode(relay_inv_ac,OUTPUT);
pinMode(relay_load2_ac,OUTPUT);
pinMode(relay_load2_sw,OUTPUT);

pinMode(s_bat1, INPUT);
pinMode(s_bat2, INPUT);
pinMode(10, INPUT_PULLUP);

// while(9){
//   digitalWrite(relay_load2_sw,1); delay(1000);
//   digitalWrite(relay_load2_sw,0); delay(1000);
//
// }

readBattery();

if( batry1 == 2 && batry2 == 2) mode =1;
if( batry1 == 0 && batry2 == 2) mode =2;
if( batry1 == 2 && batry2 == 0) mode =1;
if( batry1 == 0 && batry2 == 0) mode =3;

if( batry1 == 0 && batry2 == 1) mode =2;
if( batry1 == 1 && batry2 == 0) mode =1;

driveRelay();

}

void loop() {
  readBattery();
  show_display();
  setMode(); driveRelay();

  debug(); delay(3);
}

bool readBattery(){
  btn = digitalRead(10);
  bat1_v = analogRead(s_bat1)*0.014648;
  bat2_v = analogRead(s_bat2)*0.014648;

  if( bat1_v > threshold_H) batry1 = 2;
  else if( bat1_v > threshold_L) batry1 = 1;
  else batry1 = 0;
}

```

```

    if( bat2_v > threshold_H) batry2 = 2;
    else if( bat2_v > threshold_L) batry2 = 1;
    else batry2 = 0;

    if(btn == 1 && old_btn == 0) load2_stts = !load2_stts;
    old_btn = btn;
}

void setMode(){
    if( batry1 == 2 && batry2 == 2) mode =1;
    if( batry1 == 0 && batry2 == 2) mode =2;
    if( batry1 == 2 && batry2 == 0) mode =1;
    if( batry1 == 0 && batry2 == 0) mode =3;

    if(load2_stts){
        if(batry2) mode2 = 1;
        else mode2 = 2;
    }
    else mode2 = 0;
}

void driveRelay(){
    //2--> from battery 2 //3--> from ac

    //relay_inv_on_off// 0--> ON //1--> OFF
    //relay_inv_ac// 1--> AC connected //0--> inverter connected
    //relay_b1_b2// 0--> battery1 connected //1--> battery2 connected

    if (mode ==1){ //mode// 1--> from battery 1
        digitalWrite(relay_inv_on_off, 0);
        digitalWrite(relay_inv_ac, 0);
        digitalWrite(relay_b1_b2, 0);
    }

    if (mode ==2){ //mode//2--> from battery 2
        digitalWrite(relay_inv_on_off, 0);
        digitalWrite(relay_inv_ac, 0);
        digitalWrite(relay_b1_b2, 1);
    }

    if (mode ==3){ //mode//3--> from ac
        digitalWrite(relay_inv_on_off, 1);
        digitalWrite(relay_inv_ac, 1);
        digitalWrite(relay_b1_b2, 0);
    }
}

```

```
    if(mode2 == 0) { digitalWrite(relay_load2_sw,1);
digitalWrite(relay_load2_ac,0); }
    else if(mode2 == 1) { digitalWrite(relay_load2_sw,0);
digitalWrite(relay_load2_ac,0); }
    else if(mode2 == 2) { digitalWrite(relay_load2_sw,0);
digitalWrite(relay_load2_ac,1); }
}
```

```
void show_display(){
    lcd.setCursor(0, 0);
    lcd.print(" Solar Controller ");
```

```
    lcd.setCursor(0, 1);
    lcd.print("B1:");
    lcd.print(bat1_v);
    lcd.print("v B2:");
    lcd.print(bat2_v);
    lcd.print("v");
```

```
    lcd.setCursor(0, 2);
    lcd.print("Charging: ");
    if(mode ==1 || mode == 3) lcd.print("battery 2 ");
    else if(mode == 2) lcd.print("battery 1 ");
```

```
    lcd.setCursor(0, 3);
    lcd.print("Ld 1: ");
    if(mode == 1) lcd.print("B1");
    else if(mode == 2) lcd.print("B2");
    else if(mode == 3) lcd.print("AC");
```

```
    lcd.print(" - Ld 2: ");
    if(mode2 == 0) lcd.print("OFF");
    else if(mode2 == 1) lcd.print("B2 ");
    else if(mode2 == 2) lcd.print("AC ");
```

```
}
```

```
void debug(){
    Serial.print("B1: "); Serial.print(bat1_v);
    Serial.print(" B2: "); Serial.print(bat2_v);
    Serial.print(" mode: "); Serial.print(mode);
    Serial.print(" btn: "); Serial.print(load2_stts);
    Serial.println("");
```

```
}
```

# FYDP (P/D/C) Spring/Summer/Fall 202\_ Summary of Team Log Book/ Journal

| <b>Final Year Design Project - C Spring - 2023</b> |  |                                      |              |
|--|--|--------------------------------------|--------------|
| <b>Student Details</b>                             | <b>NAME &amp; ID</b>   | <b>EMAIL ADDRESS</b>                 | <b>PHONE</b> |
| <b>Member 1</b>                                    | Md.Arafat Rahman,<br>ID:19121090                                       | md.arafat.rahman1@g.bracu.ac.bd      | 01689809060  |
| <b>Member 2</b>                                    | Nazmun Nahar Khan Meem,<br>ID:19121109                                 | nazmun.nahar.khan.meem@g.bracu.ac.bd | 01731373291  |
| <b>Member 3</b>                                    | Omar Fahim,<br>ID:19121095   | omar.fahim@g.bracu.ac.bd             | 01878243741  |
| <b>Member 4</b>                                    | Fahim Tawfiq Khan,<br>ID:19121119                                      | fahim.tawfiq.khan@g.bracu.ac.bd      | 01734300301  |
|  |  |                                      |              |
|  |  |                                      |              |
| <b>ATC Details:</b>                                |  |                                      |              |
| <b>ATC 1</b>                                       |  |                                      |              |
| <b>Chair</b>                                       | Dr.Abu S.M. Mohsin, PhD,<br>Assistant Professor, EEE, BRAC University. | asm.mohsin@bracu.ac.bd               |              |
| <b>Member 1</b>                                    | Taiyeb Hasan Sakib, Lecturer,<br>EEE, BRAC University.                 | taiyeb.sakib@bracu.ac.bd             |              |
| <b>Member 2</b>                                    | Ehsanul Karim, Lecturer, EEE,<br>BRAC University.                      | ehsanul.karim@bracu.ac.bd            |              |
|  |  |                                      |              |

**General Notes:**

1. In addition to detail journal/logbook fill out the summary/key steps and progress of your work
2. Reflect planning assignments, who has what responsibilities.
3. The logbook should contain all activities performed by the team members (Individual and team activities).

# FYDP (P/D/C) Spring/Summer/Fall 202\_ Summary of Team Log Book/ Journal

| Date/Time/Place               | Attendee                                    | Summary of Meeting Minutes  | Responsible   | Comment by ATC   |
|-------------------------------|---|---|---|--|
| 24.01.2023<br>(Group Meeting) | 1.Arafat.<br>2.Meem.<br>3.Omar.<br>4.Fahim. | Task 01:Planning for the semester.<br>Task 02:Need to clear about CO's and PO's   | Task 01:Omar and Fahim.<br>Task 02:Meem and Arafat.                   | N/A  |
| 26.01.2023<br>(FYDP Class)    | 1.Arafat.<br>2.Meem.<br>3.Omar.<br>4.Fahim. | Introductory class of 400C of Spring 2023 semester.   |   |  |
| 31.01.2023<br>(Group Meeting) | 1.Arafat.<br>2.Meem.<br>3.Omar.<br>4.Fahim. | Task 01:Making a tentative budget for prototype.  | Task 01:Omar.   | Task 01:Partially completed.   |
| 02.02.2023<br>(ATC Meeting)   | 1.Arafat.<br>2.Meem.<br>3.Omar.<br>4.Fahim. | Task 01:Need to make a components list for our prototype.   | Task 01:Omar and Fahim.   | ATC Comments:<br>Task 01:Suggested to focus on our best design.<br>Task 02:Suggested to work with components list. |
| 03.02.2023<br>(Group Meeting) | 1.Arafat.<br>2.Meem.<br>3.Omar.<br>4.Fahim. | Task 01:Finding ways of hardware implementation.<br>Task 02:Discussion about necessary components for prototype.                                    | Task 01:Meem and Arafat.<br>Task 02:Omar and Fahim.                   | Task 01:Done<br>Task 02:Ordered most of them   |
| 08.02.2023<br>(Group Meeting) | 1.Arafat.<br>2.Meem.<br>3.Omar.<br>4.Fahim. | Task 01:Starting of hardware implementation.<br>Task 02: Update about planning of hardware implementation.<br>Task 03:Update about components list. | Task 01:Omar and Fahim.<br>Task 01:Meem and Arafat.<br>Task 02:Fahim. | Task 01:Charge battery using solar panels.<br>Task 02:Continued.<br>Task 03:Partially completed.                   |
| 14.02.2023<br>(Group Meeting) | 1.Arafat.<br>2.Meem.<br>3.Omar.<br>4.Fahim. | Task 01:Update about components list.<br>Task 02:Discussion about relay.  | Task 01:Omar and Fahim.<br>Task 02:Everyone.                          | Task 01:This task was fully completed.<br>Task 02:Discussed about ATS system.                                      |
| 15.02.2023<br>(ATC Meeting)   | 1.Arafat.<br>2.Meem.<br>3.Omar.<br>4.Fahim. | Task 01:Components list approval.<br>Task 02:Switching of batteries.<br>Task 03:Use of relay.   | Task 01:Omar.<br>Task 02:Fahim and Meem.<br>Task 03:Arafat.           | ATC Comments:<br>Task 01:Suggested to work more with components list.<br>Task 02:Suggested to buy components.      |

## FYDP (P/D/C) Spring/Summer/Fall 202\_ Summary of Team Log Book/ Journal

|                                       |   |   |  |   |
|---------------------------------------|---|---|--|---|
|                                       |   |   |  | Task 03:Making a smooth shifting of batteries and loads.<br>Task 04:Suggested to work with complex uses of relays.  |
| 16.02.2023<br>(Group Meeting)         | 1.Arafat.<br>2.Meem.<br>3.Omar.<br>4.Fahim. | Task 01:Discussion for purchasing the rest components.<br>Task 02:Working about smooth shifting of batteries.<br>Task 03:Working with complex uses of relays. | Task 01:Omar and Meem.<br>Task 02:Fahim and Arafat.<br>Task 03:Omar. | Task 01: Ordered for the rest<br>Task 02:Faced problem with inverter and trying to find out the solutions.<br>Task 03:Relay switching didn't work properly. |
| 18.02.2023<br>(Group Meeting)         | 1.Arafat.<br>2.Meem.<br>3.Omar.<br>4.Fahim. | Task 01:Purchasing components.  | Task 01:Everyone.  | Task 01:This task is fully completed.   |
| 19.02.2023<br>(Group Meeting)         | 1.Arafat.<br>2.Meem.<br>3.Omar.<br>4.Fahim. | Task 01:Components testing.<br>Task 02:Connection checking.   | Task 01:Omar and Arafat.<br>Task 02:Meem and Fahim.                  | Task 01:This task is fully completed.<br>Task 02:faced problem with the connection of relays  |
| 20.02.2023<br>(Group Meeting)         | 1.Arafat.<br>2.Meem.<br>3.Omar.<br>4.Fahim. | Task 01:Managing solar panel.<br>Task 02:Battery charging and discharging.<br>Task 03:Working on code.  | Task 01:Arafat.<br>Task 02:Omar and Meem.<br>Task 03:Fahim.          | Task 01:Checked using dc loads..<br>Task 02:This task is fully completed.<br>Task 03:worked with some modifications.  |
| 23.02.2023<br>(Group Meeting)         | 1.Arafat.<br>2.Meem.<br>3.Omar.<br>4.Fahim. | Task 01:Observing SOC by charging and discharging two batteries.<br>Task 02:Connecting loads with solar panels.<br>Task 03:Working with arduino.              | Task 01:Omar and Meem.<br>Task 02:Arafat.<br>Task 03:Fahim.          | Task 01:completed using ac supply and loads.<br>Task 02:Tested using ac loads<br>Task 03: Completed.  |
| 28.02.2023<br>(Group Meeting)         | 1.Arafat.<br>2.Meem.<br>3.Omar.<br>4.Fahim. | Task 01:Preparation for progress presentation.<br>Task 02:Making slides.  | Task 01:Arafat and Meem.<br>Task 02:Omar and Fahim.                  | Task 01:Continued<br>Task 02:This task is fully completed.  |
| 02.03.2023<br>(Progress presentation) | 1.Arafat.<br>2.Meem.<br>3.Omar.<br>4.Fahim. | Task 01:Progress presentation.  | Task 01:Everyone.  | Task 01:Submitted slide in google classroom.  |
| 03.03.2023<br>(Group Meeting)         | 1.Arafat.<br>2.Meem.<br>3.Omar.<br>4.Fahim. | Task 01:Working with feedback from progress presentation.<br>Task 02:Need to collect more components.   | Task 01:Fahim and Meem.<br>Task 02:Arafat and Omar.                  | Task 01:Noted<br>Task 02: Completed.  |
| 09.03.2023<br>(Group Meeting)         | 1.Arafat.<br>2.Meem.<br>3.Omar.<br>4.Fahim. | Task 01:Working with a switching mechanism for smooth phase shifting.   | Task 01:Omar and Meem.<br>Task 02:Fahim.<br>Task 03:Arafat.          | Task 01:Faced issues with inverter.<br>Task 02:Add small and large loads.   |



## FYDP (P/D/C) Spring/Summer/Fall 202\_ Summary of Team Log Book/ Journal

|   |   |  |   |  |
|---|---|--|---|--|
|   |   | Task 02:Working with variable loads.   |   |  |
| 14.03.2023<br>(Group Meeting)                       | 1.Arafat.<br>2.Meem.<br>3.Omar.<br>4.Fahim. | Task 01:Need to bring some changes in code.<br>Task 02:Need to change the inverter due to an accident.                                     | Task 01:Fahim.<br>Task 02:Omar.                             | Task 01:Continued<br>Task 02:Brought a new one   |
| 15.03.2023<br>(Meeting with Dr.Abu S.M. Mohsin sir) | 1.Arafat.<br>2.Meem.<br>3.Omar.<br>4.Fahim. | Task 01:Went for suggestion about switching voltage sources and loads.<br>Task 02:Reported about an accident.                              | Task 01:Omar,Meem and Arafat.<br>Task 02:Omar,Meem, Arafat. | Suggestions of Dr.Abu S.M. Mohsin sir:<br>Task 01:Suggested to work with complex switching mechanism.<br>Task 02:Suggested to work with more care as we are dealing with 220V.                                 |
| 16.03.2023<br>(Group Meeting)                       | 1.Arafat.<br>2.Meem.<br>3.Omar.<br>4.Fahim. | Task 01:Working with complex switching mechanisms  | Task 01:Omar and Arafat.<br>Task 02:Meem and Fahim.         | Task 01:Add large loads along with small loads.  |
| 20.03.2023<br>(Group Meeting)                       | 1.Arafat.<br>2.Meem.<br>3.Omar.<br>4.Fahim. | Task 01:Introduced Automatic Transfer Switch (ATS) for switching batteries and loads.<br>Task 02:Need to bring some changes in code again. | Task 01:Omar and Meem.<br>Task 02:Fahim.<br>Task 03:Arafat. | Task 01:Partially completed.<br>Task 02:Continued  |
| 23.03.2023<br>(ATC Meeting)                         | 1.Arafat.<br>2.Meem.<br>3.Omar.<br>4.Fahim. | Task 01:Giving update about ATS.<br>Task 02:Giving update about functionalities of our prototype.  | Task 01:Omar and Meem.<br>Task 02:Arafat and Fahim.         | ATC Comments:<br>Task 01:Suggested to work more with ATS.<br>Task 02:Suggested to work more with functionalities of prototype.<br>Task 03:Suggested to make some videos and capture some pictures of our work. |
| 24.03.2023<br>(Group Meeting)                       | 1.Arafat.<br>2.Meem.<br>3.Omar.<br>4.Fahim. | Task 01:Need to upgrade ATS.<br>Task 02:Need to upgrade functionalities of prototype.  | Task 01:Omar and Meem.<br>Task 02:Arafat and Fahim.         | Task 01:Continued.<br>Task 02:Added variable loads.  |
| 27.03.2023<br>(Group Meeting)                       | 1.Arafat.<br>2.Meem.<br>3.Omar.<br>4.Fahim. | Task 01:Need to update budget.   | Task 01:Omar.   | Task 01:This task is fully completed.  |
| 30.03.2023<br>(Group Meeting)                       | 1.Arafat.<br>2.Meem.<br>3.Omar.<br>4.Fahim. | Task 01:Need to bring some changes in code.  | Task 01:Fahim.<br>Task 02:Omar,Meem and Arafat.             | Task 01:This task is fully completed.<br>Task 02:Load,inverter,soc   |

## FYDP (P/D/C) Spring/Summer/Fall 202\_ Summary of Team Log Book/ Journal

|                               |   |  |  |  |
|-------------------------------|---|--|--|--|
|                               |   | Task 02:Need to bring synchronization of all parts of prototype.   |  | meter and battery added together.  |
| 03.04.2023<br>(Group Meeting) | 1.Arafat.<br>2.Meem.<br>3.Omar.<br>4.Fahim. | Task 01:Need to make some videos and capture some pictures of our work.<br>Task 02:Upgrading ATS.<br>Task 03:Testing of ATS.   | Task 01:Arafat.<br>Task 02:Omar and Meem.<br>Task 03:Fahim and Arafat. | Task 01:Captured some videos and pictures of our working.<br>Task 02:Continued.<br>Task 03:Tested and founded some problems.   |
| 06.04.2023<br>(Group Meeting) | 1.Arafat.<br>2.Meem.<br>3.Omar.<br>4.Fahim. | Task 01:Upgrading ATS with relays.<br>Task 02:Using variable loads.<br>Task 03:Using multiple sources.<br><br>(An accident happens while working with inverter.Inverter gone.) | Task 01:Omar and Arafat.<br>Task 02:Fahim.<br>Task 03:Meem.            | Task 01:Continued.<br>Task 02:This task is fully completed.<br>Task 03:Used two batteries and solar panel.   |
| 06.04.2023<br>(ATC Meeting)   | 1.Arafat.<br>2.Meem.<br>3.Omar.<br>4.Fahim. | Task 01:Reporting about the accident.<br>Task 02:Giving update about ATS upgrading.<br>Task 03:Showing videos and pictures of our work.  | Task 01:Omar.<br>Task 02:Fahim and Arafat.<br>Task 03:Meem.            | ATC Comments:<br>Task 01:Suggested to work with more safety precautions.<br>Task 02:Suggested to synchronization of ATS with other parts of prototype with more efficiently.<br>Task 03:Suggested to make videos and capture pictures of functionalities of our prototype.<br>Task 04:Guided about poster.<br>Task 05:Suggested to start report writing. |
| 07.04.2023<br>(Group Meeting) | 1.Arafat.<br>2.Meem.<br>3.Omar.<br>4.Fahim. | Task 01:Discussion about poster.<br>Task 02:Discussion about report writing.   | Task 01:Omar and Fahim.<br>Task 02:Arafat amd Meem.                    | Task 01:Discussed about how to make poster.<br>Task 02:Started report writing.   |
| 09.04.2023<br>(Group Meeting) | 1.Arafat.<br>2.Meem.<br>3.Omar.<br>4.Fahim. | Task 01:Need to buy another inverter.<br>Task 02:Need to collect data.<br>Task 03:Discussed about how we can avoid accidents.  | Task 01:Omar.<br>Task 02:Fahim and Arafat.<br>Task 03:Meem.            | Task 01:This task is fully completed.<br>Task 02:This task is fully completed.<br>Task 03:This task is fully completed.  |
| 10.04.2023<br>(Group Meeting) | 1.Arafat.<br>2.Meem.<br>3.Omar.             | Task 01:Collecting data.<br>Task 02:Analysing of collected data.   | Task 01:Fahim.<br>Task 02:Omar.  | Task 01:This task is fully completed.  |

## FYDP (P/D/C) Spring/Summer/Fall 202\_ Summary of Team Log Book/ Journal

|                               |   |   |  |  |
|-------------------------------|---|---|--|--|
|                               | 4.Fahim.                                    | Task 03:Discussion about final cost of prototype.   | Task 03:Arafat and Meem.   | Task 02:This task is fully completed.<br>Task 03:This task is fully completed.   |
| 11.04.2023<br>(Group Making)  | 1.Arafat.<br>2.Meem.<br>3.Omar.<br>4.Fahim. | Task 01:Discussion about poster making.   | Task 01:Arafat   | Task 01:Added abstract,introduction,design approach.   |
| 12.04.2023<br>(Group Meeting) | 1.Arafat.<br>2.Meem.<br>3.Omar.<br>4.Fahim. | Task 01:Update about result of prototype.   | Task 01:Omar   | Task 01:Continued.   |
| 13.04.2023<br>(ATC Meeting)   | 1.Arafat.<br>2.Meem.<br>3.Omar.<br>4.Fahim. | Task 01:Reporting about poster.<br>Task 02:Giving update about prototype.<br>Task 03:Giving update about report.  | Task 01:Arafat.<br>Task 02:Omar and Fahim.<br>Task 03:Meem.                | ATC Comments:<br>Task 01:Suggested to work details of poster.<br>Task 02:Suggested to work with more specific values.<br>Task 03:Suggested to work with economic analysis.<br>Task 04:Suggested to make a preparation of mock presentation.                          |
| 14.04.2023<br>(Group Meeting) | 1.Arafat.<br>2.Meem.<br>3.Omar.<br>4.Fahim. | Task 01:Working with more details of poster.<br>Task 02:Working with specific values of result of the prototype.<br>Task 03:Update about report.<br>Task 04:Discussion about mock presentation. | Task 01:Arafat.<br>Task 02:Omar.<br>Task 03:Meem.<br>Task 04:Fahim.        | Task 01:Added result and discussion,environmental analysis,sustainability,economic analysis,conclusion,acknowledgement and references.<br>Task 02:Partially completed.<br>Task 03:Chapter 01 to 05 added.<br>Task 04:Discussed how to conduct the mock presentation. |
| 16.04.2023<br>(Group Meeting) | 1.Arafat.<br>2.Meem.<br>3.Omar.<br>4.Fahim. | Task 01:Working on report.<br>Task 02:Working on poster.<br>Task 03:Validating the datas of result of prototype.  | Task 01:Meem.<br>Task 02:Arafat.<br>Task 03:Fahim and Omar.                | Task 01:Chapter 06 to 08 added.<br>Task 02:Edited the poster more.<br>Task 03:Continued.   |
| 19.04.2023<br>(Group meeting) | 1.Arafat.<br>2.Meem.<br>3.Omar.<br>4.Fahim. | Task 01:Update about poster.<br>Task 02:Update about report writing.  | Task 01:Arafat.<br>Task 02:Meem.<br>Task 03:Omar and Fahim.<br>Task 04:All | Task 01:Figures added.<br>Task 02:Chapter 09 to 11 added.<br>Task 03:Continued.  |

## FYDP (P/D/C) Spring/Summer/Fall 202\_ Summary of Team Log Book/ Journal

|                                  |   |   |  |   |
|----------------------------------|---|---|--|---|
|                                  |   | Task 03:Collecting pictures and videos of functionalities of the prototype.<br>Task 04:Preparation for mock presentation.   |  | Task 04:This task was fully completed.  |
| 20.04.2023<br>(ATC Meeting)      | 1.Arafat.<br>2.Meem.<br>3.Omar.<br>4.Fahim. | Task 01:Mock Presentation.<br>Task 02:Doubt clearing about final presentation or project showcase.  | Task 01:All.<br>Task 02:Fahim.   | ATC Comments:<br>Task 01:Giving feedback on poster.<br>Task 02:Giving guidelines for final presentation or showcase.<br>Task 03:Suggested to add more pictures and videos.                    |
| 21.04.2023<br>(Group Meeting)    | 1.Arafat.<br>2.Meem.<br>3.Omar.<br>4.Fahim. | Task 01:Working on poster based on ATC feedback.<br>Task 02:Working on final presentation or showcase.<br>Task 03:Collecting more pictures and videos.<br>Task 04:Final working on prototype. | Task 01:Arafat and Meem.<br>Task 02:Fahim.<br>Task 03:Arafat.<br>Task 04:Omar. | Task 01:Modified the poster based on ATC suggestion.<br>Task 02:Prepared poster and prepared the prototype.<br>Task 03:This task is fully completed.<br>Task 04:This task is fully completed. |
| 24.04.2023<br>(Group Meeting)    | 1.Arafat.<br>2.Meem.<br>3.Omar.<br>4.Fahim. | Task 01:Working on details of poster.<br>Task 02:Working on final presentation.<br>Task 03:Working on report writing.   | Task 01:Arafat and Meem.<br>Task 02:Meem.<br>Task 03:Omar,Arafat and Fahim.    | Task 01:Edited the poster more.<br>Task 02:Continued.<br>Task 03:Modified more.   |
| 25.04.2023<br>(Group meeting)    | 1.Arafat.<br>2.Meem.<br>3.Omar.<br>4.Fahim. | Task 01:Report writing.<br>Task 02:Working on poster.<br>Task 03:Working on final presentation or showcase.   | Task 01:Arafat.<br>Task 02:Meem.<br>Task 03:Fahim and Omar.                    | Task 01:Continued.<br>Task 02:Font was corrected.<br>Task 03:Continued.   |
| 26.04.2023<br>(Group Meeting)    | 1.Arafat.<br>2.Meem.<br>3.Omar.<br>4.Fahim. | Task 01:Working on final poster.<br>Task 02:Preparation for project showcase.   | Task 01:All.<br>Task 02:All  | Task 01:This task is fully completed.<br>Task 02:This task is fully completed.  |
| 27.04.2023<br>(Project Showcase) | 1.Arafat.<br>2.Meem.<br>3.Omar.<br>4.Fahim. | Task 01:Project showcase.   | Task 01:All.   | Task 01:This task is fully completed.   |
| 28.04.2023<br>(Group Meeting)    | 1.Arafat.<br>2.Meem.<br>3.Omar.<br>4.Fahim. | Task 01:Discussion about feedbacks given by faculties.  | Task 01:All.   | Task 01:This task is fully completed.   |
| 29.04.2023<br>(Group Meeting)    | 1.Arafat.<br>2.Meem.<br>3.Omar.             | Task 01:Report writing.   | Task 01:Meem   | Task 01:Added figures and added tables.   |

## FYDP (P/D/C) Spring/Summer/Fall 202\_ Summary of Team Log Book/ Journal

|   |   |  |   |   |
|---|---|--|---|---|
|   | 4.Fahim.                                    |  |   |   |
| 30.04.2023<br>(Group Meeting)               | 1.Arafat.<br>2.Meem.<br>3.Omar.<br>4.Fahim. | Task 01:Working on report.   | Task 01:Omar  | Task 01:Font corrected and added everything.  |
| 01.05.2023<br>(Group Meeting)               | 1.Arafat.<br>2.Meem.<br>3.Omar.<br>4.Fahim. | Task 01:Working on report  | Task 01:Arafat.                                     | Task 01:This task is fully completed.   |
| 02.05.2023<br>(Group Meeting)               | 1.Arafat.<br>2.Meem.<br>3.Omar.<br>4.Fahim. | Task 01:Discussion about report.   | Task 01:All.  | Task 01:This task is fully completed.   |
| 03.05.2023<br>(Group Meeting)               | 1.Arafat.<br>2.Meem.<br>3.Omar.<br>4.Fahim. | Task 01:Report Submission.   | Task 01:Meem  | Task 01:This task is fully completed.   |
| 11.05.2023<br>(Feedback given by ATC panel) | 1.Arafat.<br>2.Meem.<br>3.Omar.<br>4.Fahim. | Some valuable feedback was given by our ATC panel and suggested to address them.               |   |   |
| 11.05.2023<br>(Group Meeting)               | 1.Arafat.<br>2.Meem.<br>3.Omar.<br>4.Fahim. | Task 01:Needed to address the feedback given by our ATC panel.                                 | Task 01:All.  | Task 01:Discussed how to solve those problems and divided everyone's part.                              |
| 12.05.2023<br>(Group Meeting)               | 1.Arafat.<br>2.Meem.<br>3.Omar.<br>4.Fahim. | Task 01:Collecting everyone's part and compilation of all parts.<br>Task 02:Report submission. | Task 01:Meem and Fahim.<br>Task 02:Omar and Arafat. | Task 01:Collected everyone's part and compiled them together.<br>Task 02:This task was fully completed. |