

Investigation on Effects of Natural Dust on Photovoltaic Panels

By

Imtiaz Sultan

15121009

Md. Asif Salman

14121069

Mohammad Sohael Sattar

14321025

A thesis submitted to the Department of Electrical and Electronic Engineering in partial fulfillment of the requirements for the degree of Bachelor of Science in Electrical and Electronic Engineering

Department of Electrical and Electronic
Engineering Brac University
August 2019

© 2019. Brac University
All rights reserved.

Declaration

It is hereby declared that

1. The thesis submitted is my/our own original work while completing degree at Brac University.
2. The thesis does not contain material previously published or written by a third party, except where this is appropriately cited through full and accurate referencing.
3. The thesis does not contain material which has been accepted, or submitted, for any other degree or diploma at a university or other institution.
4. We have acknowledged all main sources of help.

Student's Full Name & Signature:

Imtiaz Sultan
15121009

Md. Asif Salman
14121069

Mohammad Sohael Sattar
14321025

Approval

The thesis/project titled “Investigation on Effects of Natural Dust on Photovoltaic Panels” submitted by,

1. Imtiaz Sultan (15121009)
2. Mohammad Sohael Sattar (14321025)
3. Md. Asif Salman (14121069)

Of Summer, 2019 has been accepted as satisfactory in partial fulfillment of the requirement for the degree of Bachelor of Science in Electrical and Electronics Engineering on 29th August.

Examining Committee:

Supervisor:
(Member)

Dr. Md. Mosaddequr Rahman
Professor, Department of Electrical and Electronic
Engineering
Brac University

Program Coordinator:
(Member)

Dr. Saifur Rahman Sabuj
Assistant Professor, Department of Electrical and Electronic
Engineering
Brac University

Departmental Head:
(Chair)

Dr. Shahidul Islam Khan
Professor and Chairperson, Department of Electrical and
Electronic Engineering
Brac University

Abstract

A Solar module is rated such that it can yield optimum output under Standard Testing Conditions (STC). But due to different environmental factors such as temperature, humidity, wind speed, dust the performance of the module is reduced gradually. Accumulation of dust on solar PV module is one such natural phenomenon. The short circuit current of PV module is reduced as deposition of dust causes shading on the panel surface. As a result, the output power of the module decreases. In this paper, the effect of dust on the performance of the photovoltaic module has been studied. Two 20 watt mono Si Photovoltaic module is investigated in this study. Results shows that clean module increase the short circuit current 12.6% from May to July. On the other hand Dusty module decrease the short circuit current 15.49% from May to July.

Keywords: Photovoltaic, dust, short circuit current.

Dedication

We would like to dedicate this to our honorable teachers and parents for their unconditional guidance and support.

Acknowledgement

We would like to thank our thesis supervisor Dr. Md. Mosaddequr Rahman, Professor, Dept. of Electrical and Electronic Engineering, Brac University, for his support, guidance and feedbacks for the completion of this thesis

Table of Contents

Declaration.....	ii
Approval	iii
Abstract.....	iv
Keywords: Photovoltaic, dust, short circuit current.	iv
Dedication	v
Acknowledgement	vi
Table of Contents	vii
List of Figures.....	ix
List of Acronyms	xi
Chapter 1	1
Introduction.....	1
1.1 Background	2
1.2 Literature Review:	2
1.3 Scope of the Work	3
1.4 Objective	4
1.5 Thesis Organization	4
Chapter 2	5
Theoretical Background.....	5
2.1: Introduction.....	5
2.2: PV cells.....	5

2.3: PV Module.....	7
2.4: Impact of Dust on PV module	8
2.5: Cause of Dust Accumulation:	11
Experimental Setup	13
3.1: Introduction.....	13
3.2: Outdoor Setup	13
3.3: Dust Sensor	16
3.4: Dust Sensor Setup.....	17
Chapter: 04.....	19
Result and Discussion	19
4.1 Introduction:.....	19
4.2 Performance test of PV modules:	19
4.3 Day wise data analysis:.....	20
4.4 Month wise data comparison	30
4.5 Percentage Comparison:	32
Chapter: 05.....	34
Conclusions.....	34
Future works	35
References.....	36
Appendix A.....	39

List of Figures

Figure 2.1: Cross - section area of PV cell.....	6
Figure 2.2: Equivalent circuit diagram of PV cell [3]	6
Figure 2.3: Structure of PV module [1]	7
Figure 2.4: Current flow through shaded cells [25 26]	9
Figure 2.5: Effect of soft shading & hard shading on module performance.....	9
Figure 2.6: Effect of soft shading & hard shading on array performance.....	11
Figure 2.7: Causes of dust accumulation.....	12
Figure 3.1: Structure of the iron frame.....	14
Figure 3.2: Mono crystalline PV module tied to the iron frame facing south.....	14
Figure 3.3: The outdoor setup of this experiment.....	15
Figure 3.4: Dust sensor [12]	16
Figure 3.5: Circuit diagram of Dust Sensor [13]	17
Figure 3.6: Circuit connection of the dust sensor.....	18
Figure 4.1: I-V curve of two PV modules.....	19
Figure 4.2: Isc and Dust Density VS Time at 9th May, 2019.....	20
Figure 4.3: Isc and Dust Density VS Time at 14th May, 2019.....	21
Figure 4.4: Isc and Dust Density VS Time at 23rd May, 2019.....	22

Figure 4.5: Isc and Dust Density VS Time at 12th June, 2019.....	24
Figure 4.6: Isc VS Time at 20th June, 2019.....	25
Figure 4.7: Isc and VS Time at 10th July, 2019.....	26
Figure 4.8: Isc and VS Time at 17th July, 2019.....	27
Figure 4.9: Isc and Dust Density VS Time at 18th July, 2019.....	28
Figure 4.10: Isc and VS Time at 21st July, 2019.....	29
Figure 4.11: Month wise short circuit of clean module (M2)	30
Figure 4.12: Month wise short circuit current of dusty module (M1)	31
Figure 4.13: Percentage Comparison of short circuit current.....	32

List of Acronyms

PV Photovoltaic

I Output current

ISC Short circuit current

Eg Energy band gap

Vcc Close circuit input voltage

GND Ground

EVA Ethylene vinyl acetate

RH Relative humidity

Voc Open circuit voltage

STC Standard testing condition

Ish Shunt current

ID Diode current

IL Light current

Rsh Shunt resistance

Rs Series Resistance

Chapter 1

Introduction

Electricity that is produced around the world is mostly generated from the non-renewable energy sources. These non-renewable energy sources will be depleted soon in the future due to the rise in demand. For which the modern world is focusing on renewable sources of energy, which does less harm to the environment. Solar energy as of till now is proven to be the most clean form of renewable energy. Besides it is long lasting and uses sunlight for its generation of electricity. This whole process of conversion from sunlight to electric cell is the PV process which is easily done by PV cells. PV cells convert solar energy to DC electricity. Edmund Becquerel, a French scientist in 1839 discovered electricity due to photovoltaic effect but efficiency was low [14]. The output of Solar cell is proportional to the sunlight intensity. The application of solar energy has become wider, with the solar photovoltaic industry's combined global revenue of US\$37 billion in 2008 [15]. Previous studies has found that other environmental factors such as humidity, temperature, wind-speed, dust etc. plays a vital role on the efficiency of PV modules. However, the impact of dust on PV panels is neglected by many. In the present article, an empirical analysis based on a thorough review has been conducted. The experiment has been carefully analyzed, and the objective of this paper is to present a review of the impact of dust accumulation on the performance of PV panels from an empirical viewpoint.

1.1 Background

With the rise in demand for electricity, government of Bangladesh has made it mandatory for high rise buildings in the metropolitan to have PV system on the topmost roof. As the actual amount of electricity produced in Bangladesh is less than the demanded electricity, the PV modules are playing a vital part in decreasing the demand for electricity from national power grid. The areas which are not under the area of national power grid are mostly dependent on the PV system now to meet their energy requirements. A land of six seasons, Bangladesh has higher sunlight intensity directly in summer and transversely in winter. For receiving maximum solar energy in Bangladesh solar panel is tilted 23.7° (sun's inclination angle with respect to the ground surface in Bangladesh)[16]. Bangladesh on an average receives around 3.82-6.43 kwh/m² of solar irradiation out of which around 47.3% of the energy is received at frequencies from visible range ($0.38 < \lambda < 0.78\text{mm}$). Since the early 1960s, scientists have noticed and studied the reduction of the collectors' performance due to the pollution on a solar cells' surface. Such studies, at that time, were focused mainly on the thermal cells and the effects of dust accumulation on the mirror reflectance (Dietz 1963). Sand and soil are among the primary sources of natural degradation, among other airborne particles, chemical weathering processes, as well as industrial carbon and other types of dirt. It also restrict the sun light fall onto the solar panel.

1.2 Literature Review:

A solar panel works throughout the weeks, months and years to provide us with green energy. During the day time, when the irradiance is higher, the PV modules generate maximum power. However, other environmental parameters such as humidity, temperature, wind speed and dust have an effect on the performance of solar cells. Dust have an effect on the performance of solar cells. Previous studies have shown that dust can reduce solar cells efficiency by about

20% [17, 18, 21] and in some extreme places such as the desert, the efficiency can be reduced up to 60% [20]. Moreover, smaller dust particles tend to affect the solar panels more than that of larger dust particles. Smaller dust particles can pack themselves more closely, affecting the number of photons reaching the solar cells. [18, 20]. In contrast, under greater radiation the effect of dust becomes slightly reduced but not negligible [18, 21]. Dust also increase the temperature of the solar cells which in terms reduces V_{OC} and thus power is reduced [19].

Re-suspension and deposition of dust takes place at the same time. In the short term, the rate of accumulation of dust is depended on other external factors such as humidity and wind speed. Accumulation of dust decreases at higher wind speed because re-suspension rate exceeds deposition rate. When RH exceeds 60%, particle re-suspension rate fell and as a result accumulation of dust increases. Dust accumulation is more favorable during the night time when the wind speed is low and RH is higher [23].

In the long term, rainfall plays a vital role in the accumulation of dust on the solar panels. Research has shown that even 1mm of light rain is enough to clean the panels to an extent where the panel again operates to its ideal condition [17, 24, 22]. Panel tilt angles also play an important role in accumulation of dust. An ideal tilt angle can help accumulation of dust to reduce and transmittance of more photons to the solar cells [22]. A tilt angle can also help to clean the panels by itself even at a light slower rain [24].

1.3 Scope of the Work

The scope of this work is to study the performance of photovoltaic module under outdoor condition. The dust impact on photovoltaic module is investigated. All the data of short circuit current and the dust accumulation are collected under real climate condition. Data from May to July was collected during the study. Dust sensor is used to investigate the presence of dust

particles around the modules. All the data is analyzed to understand the performance of clean and dusty module in outdoor condition.

1.4 Objective

The objective of this study is to analyze the performance of the two photovoltaic modules at high rise buildings in Dhaka city; one is clean and another is dusty during the month of May to July. This study assesses the output parameter short circuit current to understand by how much the dust accumulation can impact on the PV module. As the months of May to July are in summer season, temperature is naturally high. Also wind speed and the rain occur frequently. Thus dust deposition increase. This study investigates the effect of dust on PV module performance during the period May to July 2019.

1.5 Thesis Organization

This thesis book is later on divided into four sections to better observe the result of our studies. Chapter 2 describes the theoretical background of this study to give a better understanding that are the base of this work. In Chapter 3 the experimental setup and sensor setup that was used to perform this standardized study is explained. Chapter 4 contains the outcome of this study as result and discussion. Finally Chapter 5 concludes the experimental study.

Chapter 2

Theoretical Background

2.1: Introduction

It is very much necessary to have a depth understanding on the theoretical background of PV module before carrying out an experiment. Studying on how PV module will give us an idea on what to expect from the experiment and how it can be done and analyzed effectively. In this chapter we will focus on the theoretical side of the PV module and how dust could affect the performance of the PV modules.

2.2: PV cells

PV cells are the building block of a solar system. A PV cell converts solar energy into electrical energy. They are made up of silicon semiconductors due to its ideal characteristics. A semiconductor has a very small band gap. Small amount of energy is required for excitation. When an electron in the valence band is excited it can easily move to the conduction band due to small band gap, thus electron can move within the material. If a photon has energy greater than the band gap (E_g), it will excite an electron to move from the valence band to the conduction band. However, PV cells are more like a photodiode (p-n junction), where as in conventional PV cells the top n layer is thin and heavily doped whereas the bottom p layer is thick and lightly doped. Due to heavily doped n side and lightly doped p layer the depletion region in PV cells is wider. This means the solar energy has a wider area to generate electron hole pair and due to the thin n layer more light can reach the depletion region. As a result more

current generation by the PV cells is possible. When a load is connected to a PV cell; current starts flowing to the electric field in the depletion region [6].

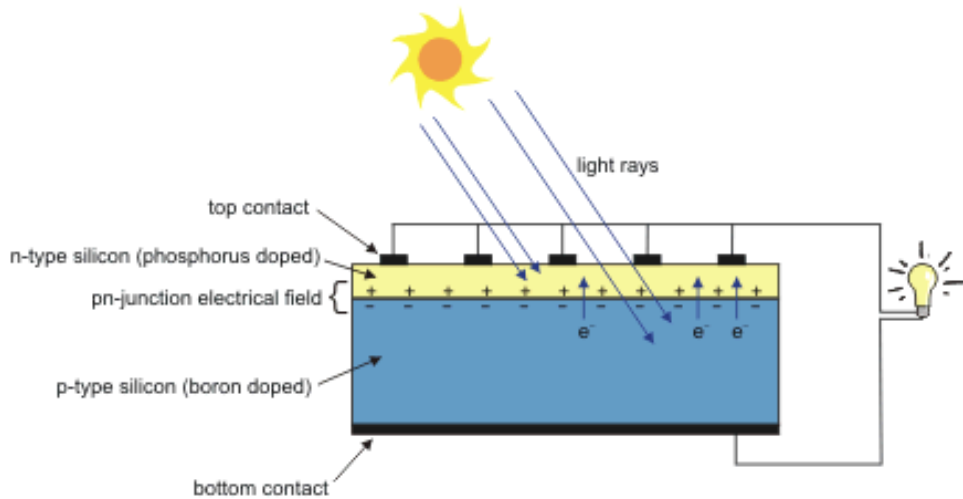

Figure 2.1: Cross section of a PV cell [2]

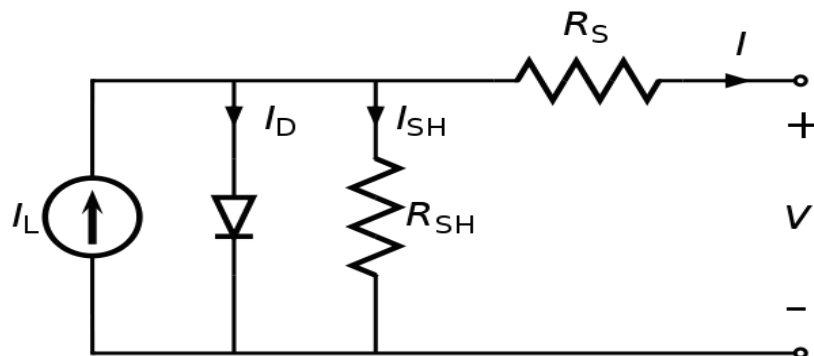

Figure 2.2: Equivalent circuit diagram of PV cells [3]

The figure above is the equivalent circuit diagram of PV cells. In the figure, the notation I_{SH} , I_D and I_L indicates the shunt current, diode current and light current respectively. The notation R_{SH} and R_S represents shunt resistance and series resistance respectively [4]. The light current is due to formation of charge carrier by the incident radiation. The shunt diode represents

recombination of these charge carriers at a high forward-bias voltage ($V+IR_S$) [4]. The shunt resistor indicated high-current paths through the semiconductor along mechanical defects and material dislocations [4].

The output current (I) of the PV cell can be expressed as equation [4]

$$\begin{aligned}
 I &= I_L - I_D - I_{SH} \\
 &= I_L - I_S \left(e^{\frac{q(V+IR_S)}{nKT}} - 1 \right) - \frac{V+IR_S}{R_{SH}}
 \end{aligned} \tag{1}$$

2.3: PV Module

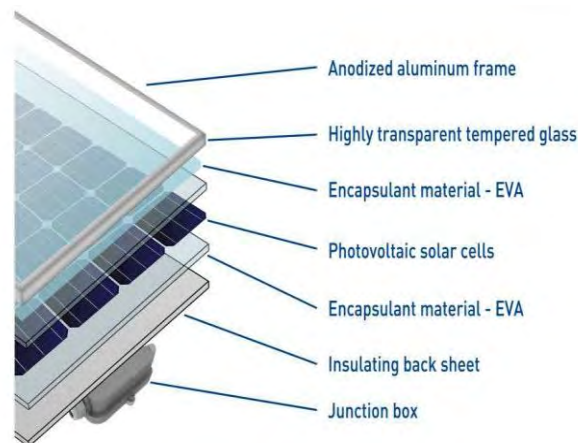

Figure 2.3: Structure of a PV Module [1]

A solar cell can generate a very little amount of electricity but by connecting several PV cells together, we could generate a useable amount of current. A PV module consists of solar cells being connected to produce renewable energy. If we look closely we would see that a solar module is made up of series of PV cells covered by EVA and transparent tempered glass at the top, the bottom part is covered by EVA and insulating sheets. The edges of a solar module are

protected by light aluminum frame. There is a junction box at the bottom of the module for connecting wires.

There are two types of popular crystalline module found in the market and they are mono crystalline PV module and polycrystalline PV module. Mono-crystalline module is made up of mono-crystalline PV cells and polycrystalline module is made from poly-crystalline PV cells. Poly-crystalline PV cells are made up of many small silicon crystals that molds into square wafers [5]. In mono-crystalline solar cells lies a single cell produced from highly purified silicon. The difference between mono and poly-crystalline PV modules is that mono crystalline modules have higher efficiency than poly-crystalline PV modules. The cost of Polycrystalline modules is cheaper than mono crystalline [5].

2.4: Impact of Dust on PV module

The efficiency of a PV module is affected by other environmental factors, Dust is among one of the factors that can affect performance of PV modules by as much as 20% depending on the geographical landscape. The dust particles accumulated on the surface of a PV module acts as a barrier between the solar cell and the sunlight. The accumulated sand particles on a horizontal glass surface reduce the available area for transmission of photons exponentially. [16] The Photons from the sunlight bounces back as they came across a dust particle. This causes a drop in irradiance on the PV cells [8]. A sample of dust can contain particles of different sizes and shapes. The finer the dust particles the more the less sunlight could reach the solar cells. Research has shown that bigger dust particles have fewer effects on the solar panel than that of smaller dust particles. The effects of dust on PV module depend on the shape, composition, color of the dust particles. However, effects of dust become slightly reduced under higher irradiation. [Effects of dust on per of PV panels]

Dust particles also increase the temperature on top of the solar module. Thus due to dust particles the rise in temperature also affects the PV module. Higher module temperature affects the energy dissipation of photons with energy value higher than semiconductor's band gap [9].

In addition to energy reduction, some soil patches, dirt block some cells of a PV module but

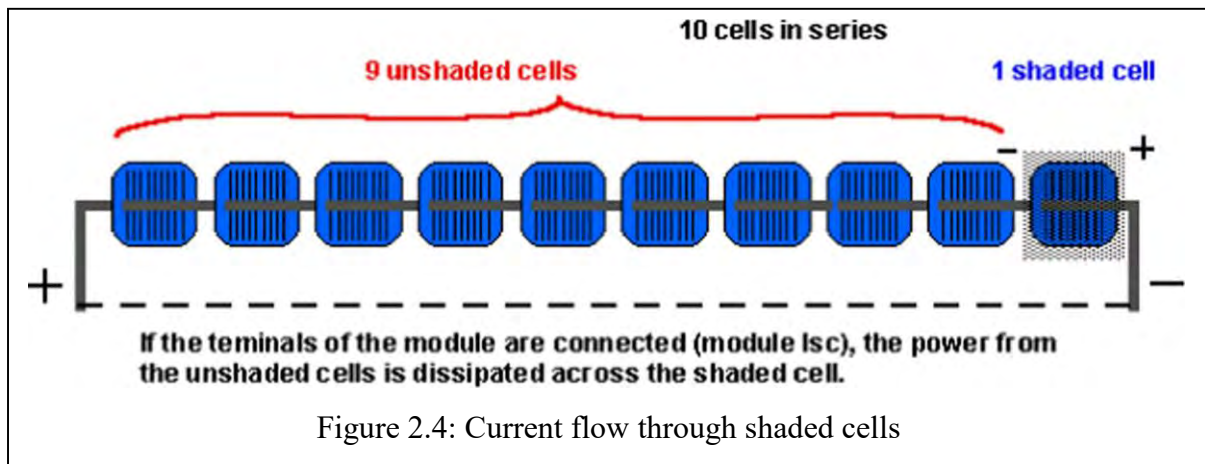

not the whole, have a severe effect on PV modules. Figure 2.4 shows a PV module consisting of 10 cells and with one cell shaded and unable to produce any current. As the figure shows, in this condition the shaded cell acts as a resistance to current generated from the other cells. This causes the shaded cell to heat up and leads to a hot spot that can eventually damage the module [25, 26]

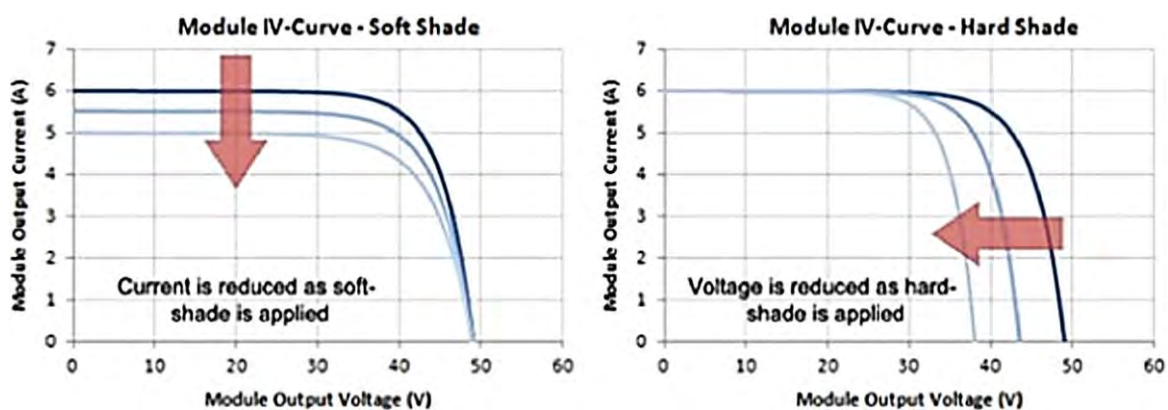

Figure 2.5: Effect of soft shading and hard shading on module performance

There are two types of soil shading on PV modules, namely, hard shading and soft shading. Hard shading occurs when a solid such as accumulated dust blocks the sunlight in a clear and definable shape. On the other hand, soft shading takes place when some particles such as smog in the atmosphere or some dust on the surface of the PV modules reduces the overall intensity of the solar irradiance which is absorbed by solar cells. Each of these types of shading has a different effect on the PV modules. Soft shading affects the current of the PV module, but the voltage remains the same. For hard shading, the performance of the PV module depends on whether some cells are shaded or all cells of the PV module are shaded. If some cells are shaded, then as long as the unshaded cells receive some solar irradiance, there will be a current flow. Fig. 2.5 shows how each type of shading affects the voltage and current of a PV module. [25]

In the case of more than one string in a PV array, the current imbalance in one string, which is as a result of shading, affects the other strings in parallel through the common inverter connected to the parallel strings. Hard dust on a surface of a PV array with single string will reduce the voltage of the string, but the inverter will detect this reduction and immediately regulate it. However, when there is uneven hard dust on different strings in parallel, a voltage mismatch occurs. In this condition, which is called partial shading, different parallel strings, which are connected to a common inverter, deliver different voltages to the inverter. This makes it difficult for the inverter to seek the optimum point of voltage at which the maximum

power is delivered. Fig. 2.6 presents the voltage–current and voltage–power curves of a PV array under this condition. [26]

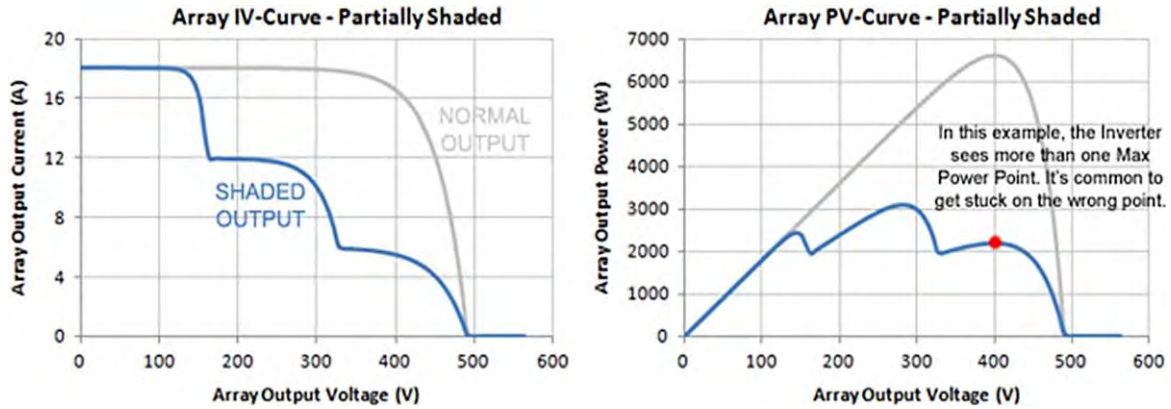

Figure 2.6: The effect of soft shading and hard shading on array performance

2.5: Cause of Dust Accumulation:

The parameters that effects on characterization dust accumulation on solar panels are size, composition and weight of dust particles, and the geographical location.[27] The geographical location refers to the buildings, trees, human activity, lakes, climate, etc.

Moreover, the surface of a PV module is an important factor for dust accumulation [27]. Rough and sticky surface area can increase dust accumulation. The tilt angle of the PV module also affects accumulation of dust particles. The higher the tilt angle, the less dust accumulation is studied. Additionally, the altitude at which the modules are set also affects accumulation of dust. At higher altitude, the wind speed is higher which also effects in dust accumulation.

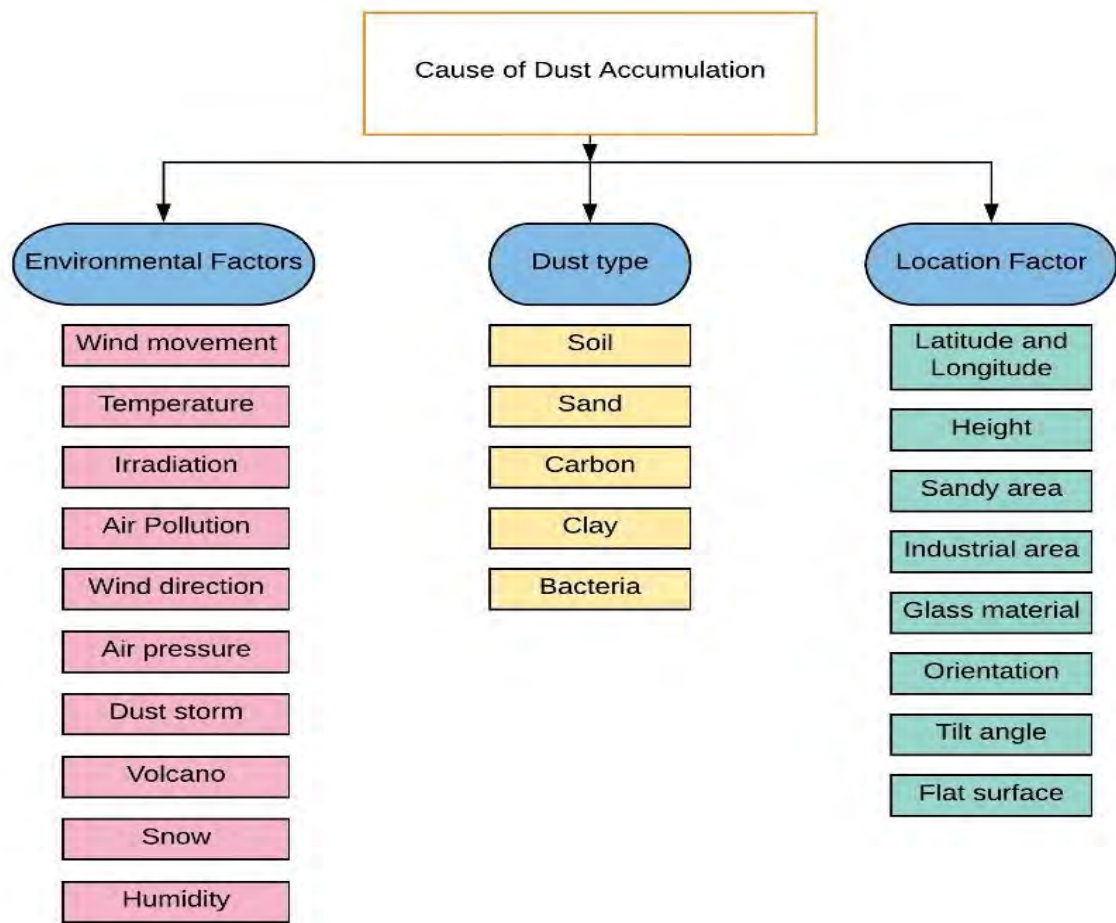

Figure 2.7 Causes of Dust Accumulation

Chapter 3

Experimental Setup

3.1: Introduction

The experiment was based on real data collection without artificially influencing the factors affecting the PV modules. All the parameters and factors related to the experiment was kept under natural conditions. It is very crucial to have a proper setup to carry out an effective experiment. To collect better and more effective set of data, the setup must be done properly to avoid any error in the experiment. The components used and the outdoor setup for this experiment will be explained in the following chapter.

3.2: Outdoor Setup

To carry out an experiment under natural conditions, a lot of planning was done before hand. At first, the location for the experiment to be carried out was selected. To fulfill our objective we planned to build the setup in a higher rise building. For this, the rooftop of BRAC University building no. 04 was selected. The building is located in Mohakhali, a very congested and populated area in Dhaka. The landscape around the building is urban, the building is surrounded by lakes, slums, playground, fewer trees and other high rise buildings. The building is a 16 storied building with other taller buildings around it. Setting the experiment at such location was practical and seems much more ideal for getting more irradiance.

Later, two iron frames was constructed in workshop to hold the modules at an optimum tilt angle of 23.5 degrees.



Figure 3.1: Structure of the iron frame



Figure 3.2: Mono crystalline module tied to the iron frame facing south

The iron frames were then fixed at the rooftop through cementation to make sure the modules stays fixed and does not get damaged during storm. The iron frames were cemented facing south direction so that the modules would also face south to obtain as much as sunlight

throughout the day. As discussed in the previous chapter the efficiency of mono crystalline PV modules is better than that of poly crystalline PV modules, using the mono crystalline for the experiment is of our best interest as the experiment is done in small scale and cost is not a factor. Two mono crystalline PV were selected and brought. The performances of both the panels were tested on the same rooftop at BRAC University. It was seen that both the module was performing relatively same. The details about the performance of the modules are discussed in the next chapter. The modules were then tied to the iron frame using plastic ties available in the local market.



Figure 3.3: The outdoor setup of this experiment

Wires were connected to the junction box of both the module. From the two modules, one was named M1 and the other was named M2. Throughout the whole experiment M1 was set to stay uncleaned whereas M2 was cleaned before every data collection. To read the short circuit current two digital multi-meters were used. Beforehand, the multi-meters were checked to see if both were showing the same results. A dust sensor was used to take dust density reading in the air. The sensor was set around the modules. A brief discussion about this dust sensor is discussed in the later part of this chapter.

3.3: Dust Sensor

The dust sensor used in this experiment is known as Sharp GP2Y1014AU0F dust sensor. This is an analog sensor and is available at various electronic components supplier. This sensor works by light scattering principle. Inside the sensor there is an LED emitter and photo detector. There is a hole in the sensor through which air passes [11]. The sensor measures the amount of dust particles passing through the hole using light scattering. The more the dust particle passes through the sensor, the higher the voltage output. The dust density can then be figured out by using linear relation from the voltage output [11]. The sharp dust sensor can detect particles as small as 0.5 microgram. It has a sensing capacity of less than 1 second. Unlike its previous version the accuracy of this sensor is found out to be as good as +/- 15% with sensitivity of $0.5 \pm 0.075V$ per 100 microgram per meter cube change [11].



Figure3.4: Dust sensor [12]

3.4: Dust Sensor Setup

The sharp dust sensor is an analog device and it also need an input voltage of 5V to operate. As a result, a circuit is needed to supply power to the sensor, Using Arduino Uno we formed a circuit which can give 5V input to the dust sensor as well convert the analog data to an understandable output. The equation to convert voltage to dust density is put in the code. The output pin configuration is as follows, the first output pin represents V-Led , the second pin is Led Gnd, the third pin is Led, the four pin is S-Gnd, Fifth pin is for Vo and the last pin is for Vcc [13]. The circuit setup using Arduino Uno is shown in the figure below. The Arduino Uno in the circuit is powered by a Laptop using data cable. The sensor was set in close range besides the module. The sensor was fixed at a height equal to the center of the modules from the base.

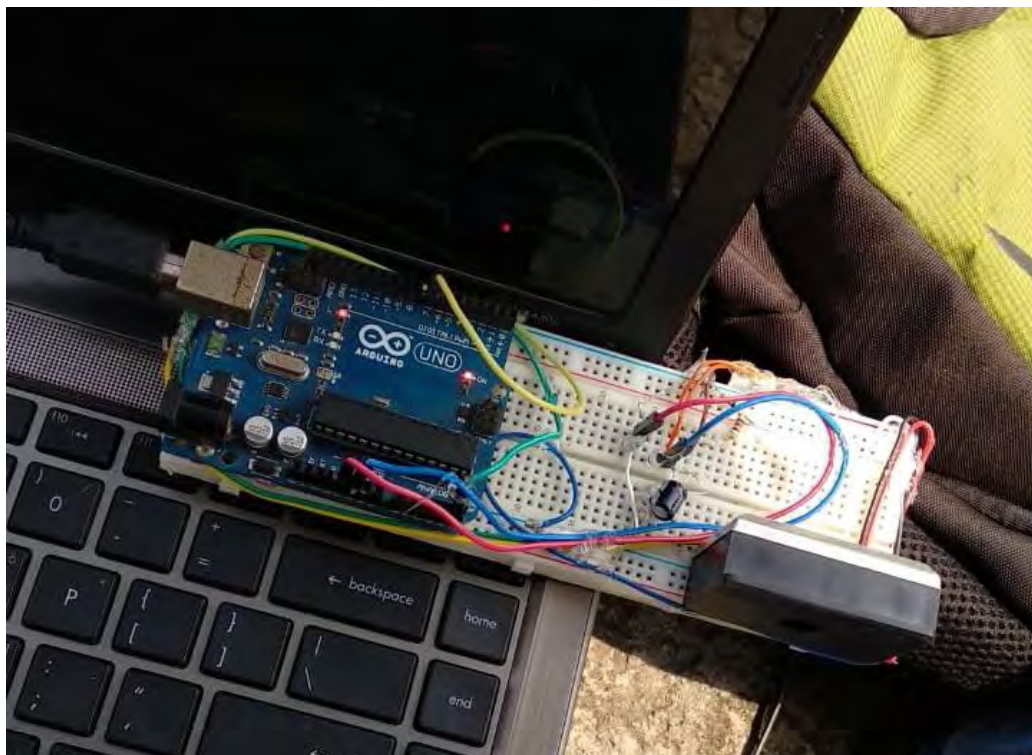

Figure 3.5: Circuit connection of the dust sensor

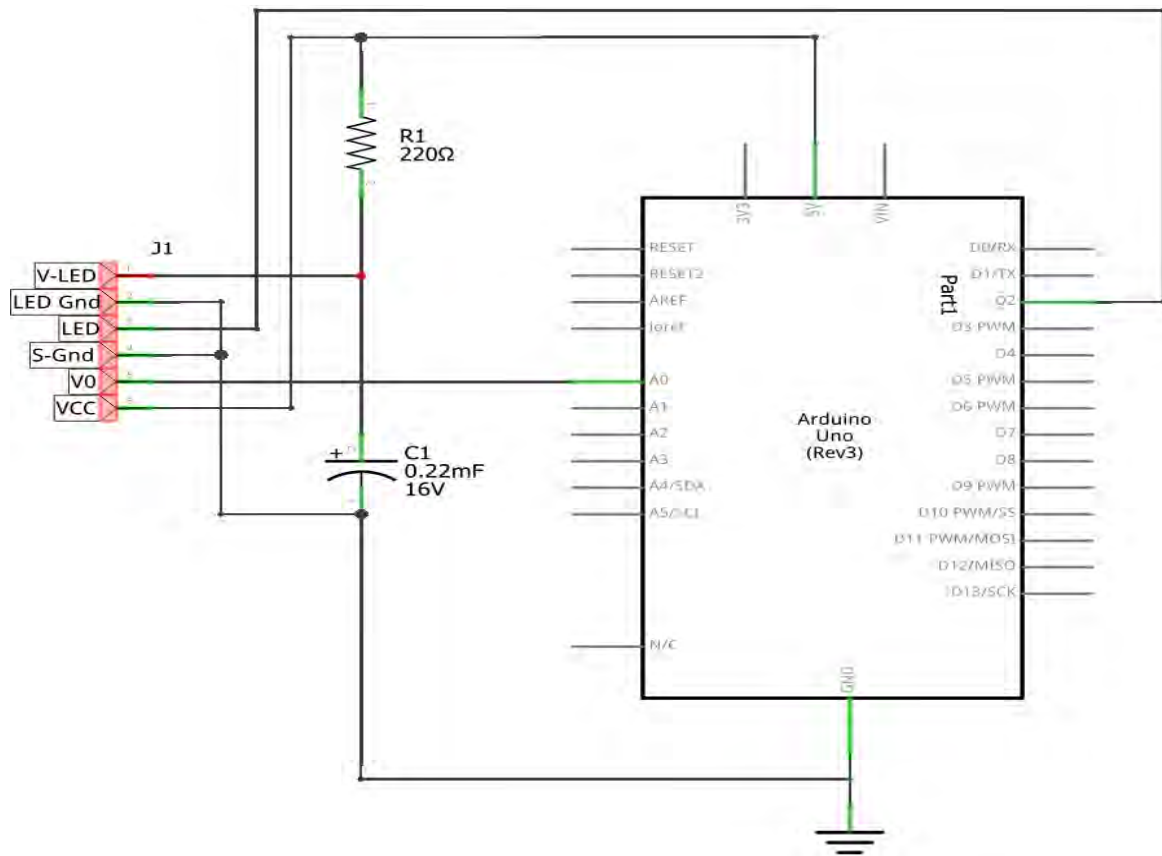

Figure 3.6 Circuit diagram of Dust Sensor [13]

Chapter: 04

Result and Discussion

4.1 Introduction:

The following chapter presents the real data that we have obtained from the outdoor setup mentioned at previous chapter. This data was collected at various days during the months of May, June and July. The first set of data was taken one week after the panels were setup.

4.2 Performance test of PV modules:

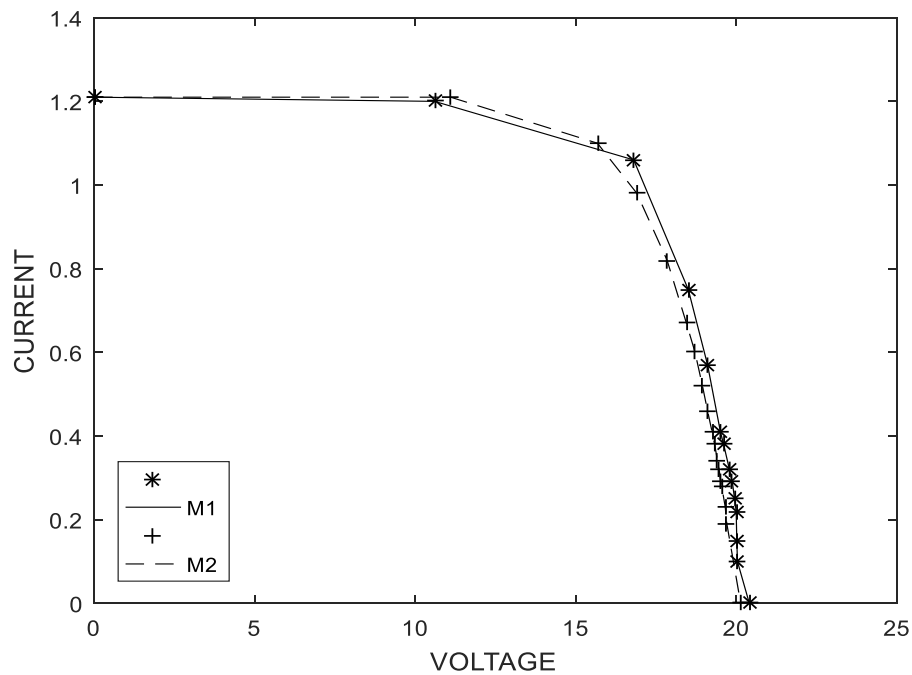

Figure 4.1: I-V curve of two PV modules

For comparative analysis it is necessary to have modules that have the same I-V characteristics. In the previous chapter, it was mentioned that two mono crystalline module is used in the experimental setup. However, before setting the modules in the experiment, the performance

of the modules is tested to see if they provide the same results under the same conditions. In the Figure 4.1, the I-V curve of both the mono crystalline PV modules is presented under outdoor testing condition in a sunny day 2nd May, 2019 at 12pm. By visually looking at the graph, it can be understood that both the modules show the same degree of performance. The short circuit current for both the module is approximately the same. In the graph, as voltage increases both the module relatively same change in current. In contrast, the little bit difference seen in the graph is too small to take into consideration.

4.3 Day wise data analysis:

9th May, 2019:

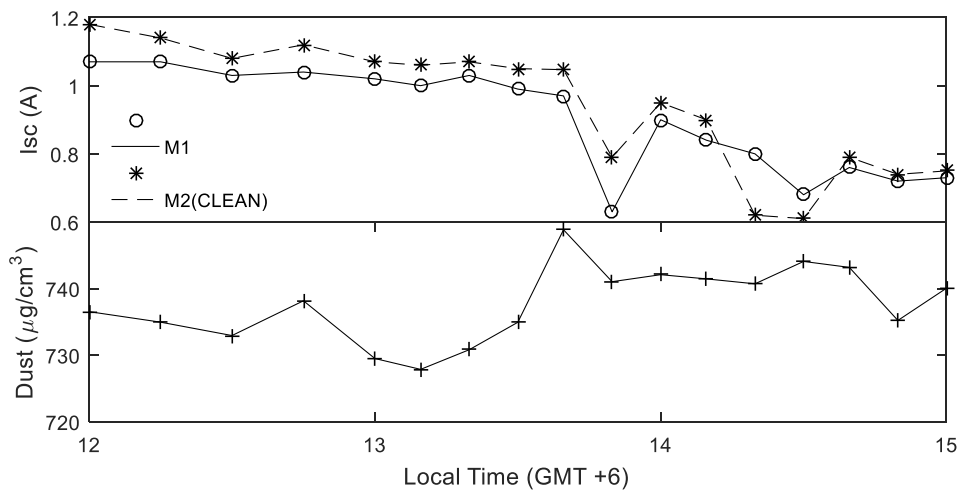

Figure 4.2: I_{sc} and Dust Density VS Time at 9th May 2019

The Figure 4.2 presents data collected on 9th May 2019. The top figure shows short circuit current of dusty (M1) and clean (M2) and dust density from the sensor for a time period of three hours. The data were taken from 12 pm to 3 pm. The bottom Figure presents dust density corresponding to that particular time period. In the figure we can observe that there is comparatively steady reading of short circuit current of M1 and M2 from 12pm till 1:40pm. At about 12:50pm there is an instant drop of short circuit current for both M1 and M2. At 12:50pm,

M1 experiences drop of short circuit current by 35% and for M2 the deterioration in short circuit current is by about 24.5% from that of previous reading. During the data collection it was observed that deterioration at 12:50pm was due to shade by clouds over that location. At the later part of the day, the short circuit current for both M1 and M2 remained low due to cloudy weather.

The readings from the dust sensor that is being used will not instantly show any relation with the short circuit current of the modules but by looking at the dust sensor reading we would gain an understanding of the presence of dust around the modules in the given time frame. If we look at the reading from the dust sensor it can be observed that the dust density in the air remains very random throughout the whole period. The dust sensor also experiences fall in reading at around 1:30 pm. At some points there is a rise in dust density due to build-up of wind speed, such as during 13:40pm and 2:30 pm.

14th May, 2019:

The figure 4.3 shows data collected on 14th May 2019. The night before the 14th May there was a shower of rain and it can be predicted the rainfall had some effect on the accumulation

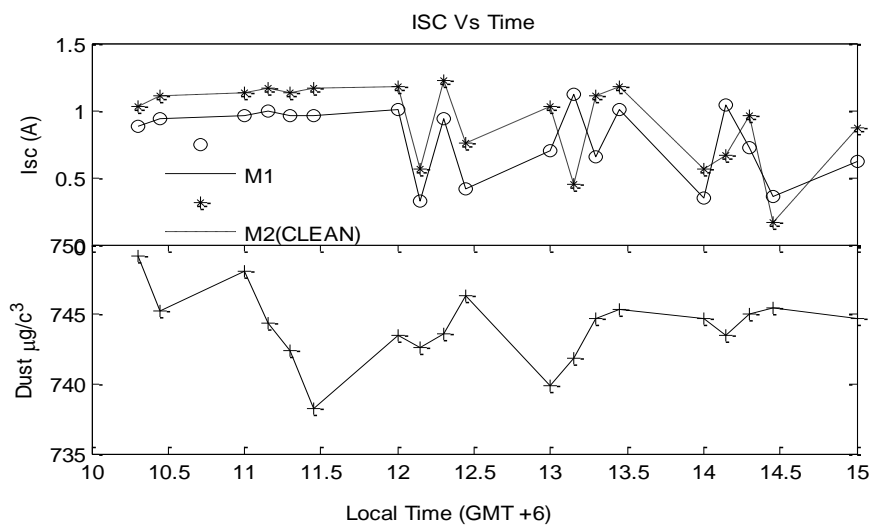

Figure 4.3: I_{sc} and Dust Density VS Time at 14th May 2019

of dust on the modules. The figure presents short circuit current for a period of four and a half an hour. The data were taken from 10:30 am to 3 pm. This Figure also presents dust density corresponding to that particular time period. In the figure we can observe that there is a relatively steady reading of short circuit current of M1 and M2 from 10:30am till 12am. At about 12:15pm there is an instant drop of short circuit current for both M1 and M2. At 12:15pm, M1 experiences drop of short circuit current by 67.3% and for M2 the fall in short circuit current was by about 51.6%. During the data collection it was observed that deterioration was cause of cloud shading. Later, both the module again reach to a higher value of 0.94 ampere and 1.224 ampere respectively for M1 and M2 at 12:30. Moreover, readings from both the PV module M 1 and M2 keep on fluctuating throughout the rest of the day this is due to movement and build-up of cloud on the horizon.

If we take a look at the reading from the dust sensor for 14th May 2019, it can observe that the dust density in the air remains very random for the chosen time frame. The dust sensor also experiences lowest reading at around 11:50 pm. The reading from dust sensor kept fluctuating until 1:30 pm; from then on the dust density stays relatively steady till the end of the time frame.

23rd May, 2019:

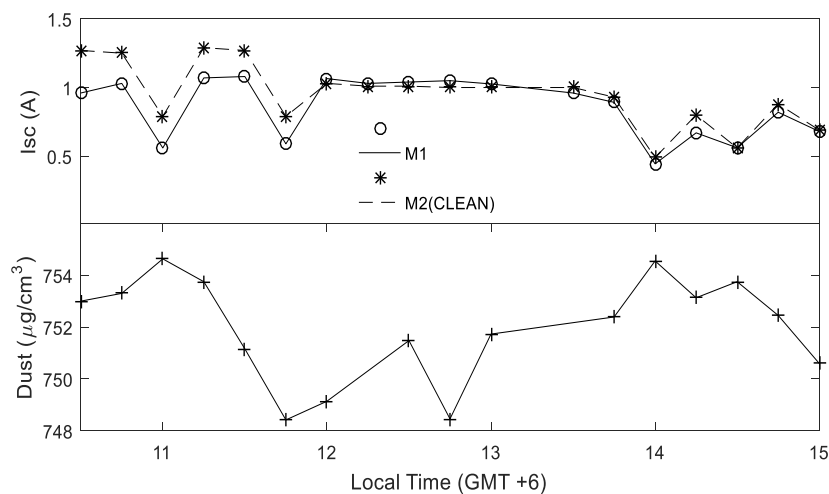

Figure 4.4: I_{sc} and Dust Density VS Time at 23rd May, 2019

The figure 4.4 shows data collected on 23rd May 2019. The day was sunny and we recorded some high readings in short circuit current for the modules during the month of May. However, the later part of the time frame we observed cloudy atmosphere. The figure presents short circuit current and dust density for a period of four and a half an hour. The data were taken from 10:30 am to 3 pm. In the figure we can observe some high reading at beginning of the time period. At 10:45am the reading for M2 reaches as high as 1.25 ampere and for M1 (dirty panel) is was 1.03ampere. At about 11am there is an instant drop of short circuit current for both M1 and M2. At 11am, M1 experiences drop of short circuit current by 45.6% and for M2 the deterioration in short circuit current was by about 36.8% from that of previous reading.. During the data collection it was observed that deterioration was cause of cloud shading. Later, both the module again reaches to a higher value of 1.07 ampere and 1.29 ampere respectively for M1 and M2 at 11:15 am and stays quite stable until 11:45am, where short circuit current again falls. From 12am till 1:30 pm the short circuit current remains relatively stable for both the M1 and M2. The later part of the period we recorded some lower readings due to slightly cloudy weather.

If we take a look at the reading from the dust sensor for 23rd May 2019, it can observed that the dust density in the air remains very random for the chosen time fame. At some points such as at 11am and 1:45pm till 3pm it was observed that the reading dust density is higher. The cause for this can be explained as the wind speed suddenly increased due to the spontaneity of the weather and presence of clouds on the horizon.

12th June, 2019:

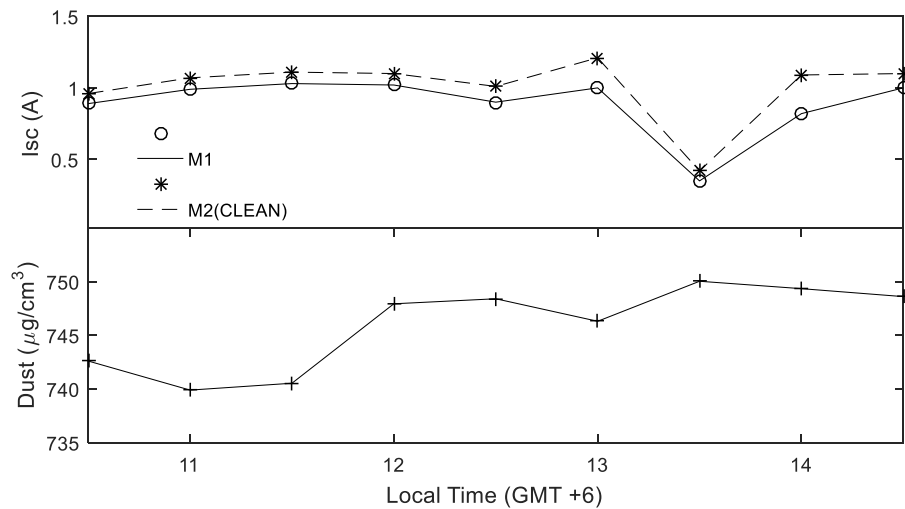

Figure 4.5: I_{sc} and Dust Density VS Time at 12 June, 2019

The figure 4.5 shows data collected on 12th June 2019. The day was sunny and we recorded relatively constant short circuit current for a long period. In the figure, the short circuit current and dust density are graphed for a period of four hour. The data were taken from 10:30 am to 2:30 pm. The short circuit current for both the module showed quite a stable pattern. At 1:30pm there is drop in the short circuit current for both M1 and M2. The drop in I_{sc} was about 65% for both the module. Other than that throughout the time period the short circuit current showed relatively stable pattern for both the module, for M1 it maintained a range from 0.89 - 1.03 ampere and for M2 the range was 0.96 - 1.21 ampere. By having a look at the readings from the dust sensor for 12 June 2019, it can be observed that the dust density in the air shows little spontaneity for the chosen time frame. On that date the pattern in dust density indicates a rise in dust particle as the day progresses. The highest reading in dust density was observed at 1:30 on that day.

20th June, 2019:

The figure 4.6 shows data collected on 20th June 2019. The weather was hazy and as a result

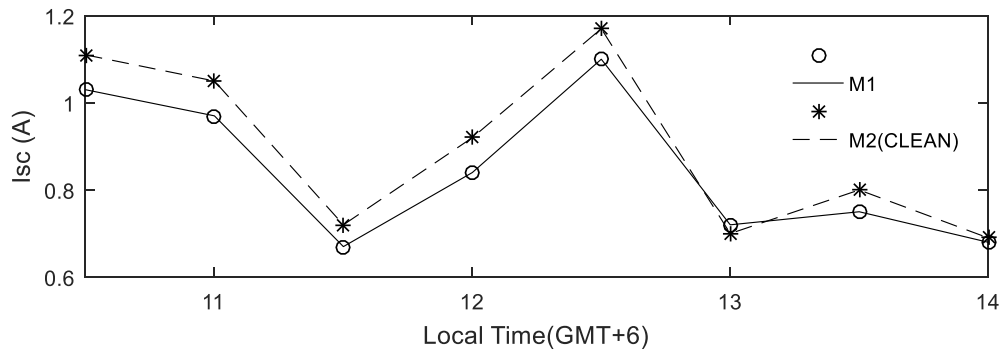

Figure 4.6: I_{sc} VS Time at 20 June, 2019

we observed low short circuit readings on that day in comparison to the previous days. In the figure, the short circuit current is plotted for a period of four hour. The data were taken from 10:30 am till 2 pm. In general, if we look at the graph, the short circuit current seems to be relatively decreasing as the day progresses. At 12:30pm there is a sudden rise in the short circuit current for both M1 and M2. For M1 the rise in I_{sc} was about 31% and for M2 the rise in short circuit current was 27% from their previous reading. The rise was due to an increase in sunlight intensity. Other than that throughout the time period the short circuit current showed relatively steady decline in short circuit current for both M1 and M2.

10th July, 2019:

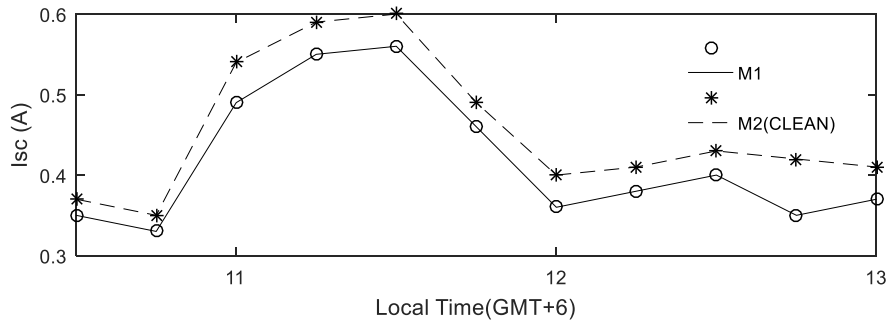

Figure 4.7: I_{sc} VS Time at 10th July, 2019

The figure 4.7 shows data collected on 10th July 2019. The weather was very cloudy and thus the short circuit current that we obtained showed a pattern of lowest readings every recorded in our whole experiment. In the figure, the short circuit current and is plotted for a period of four hour. The data were taken from 10:30 am till 1 pm. As the sky was clouded, the irradiance on the modules were low. As a result the reading came out to be very low. The dirty module M1 kept fluctuating from a range of 0.33 - 0.56 ampere and clean module M2 maintained a range of 0.35 - 0.60. Though at the beginning the reading kept on rising steadily at the beginning but after 11:30 am the reading started declining and maintained relatively steady state from 12am till 1pm.

17th July, 2019:

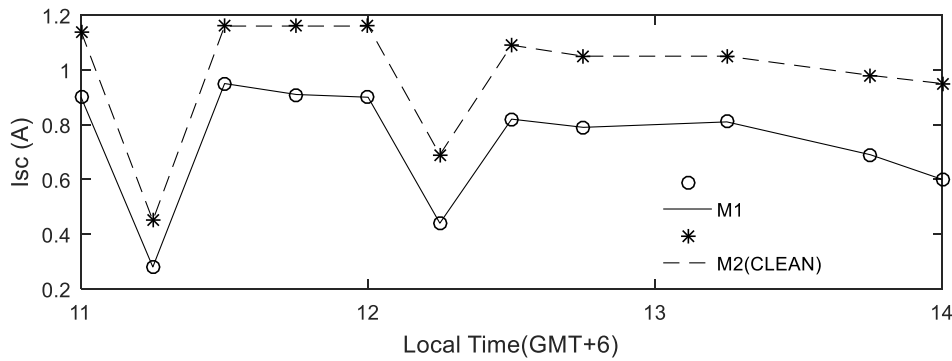

Figure 4.8: I_{sc} VS Time at 17 July, 2019

The figure 4.8 shows data collected on 17th July 2019. The weather was mostly sunny and at sometimes the sky was partially cloudy. In the figure, the short circuit current is plotted for a period of three hour. The data were taken from 11 am till 2 pm. If we look at the graph, the short circuit current readings shows less fluctuation and a steady decline as day progresses except for 11:15 am and 12:15 am, when the sky was partially cloudy. At around 11:15 am the drop in short circuit current was 68.8% and 60.5% in comparison to their previous reading for M1 and M2 respectively. At 12:15 pm the drop in reading was 51.1% and 40.5% compare to their previous reading for M1 and M2 respectively. At the later part of the day it was observed that the short circuit current was declining for both the module due to lower irradiance.

18th July, 2019:

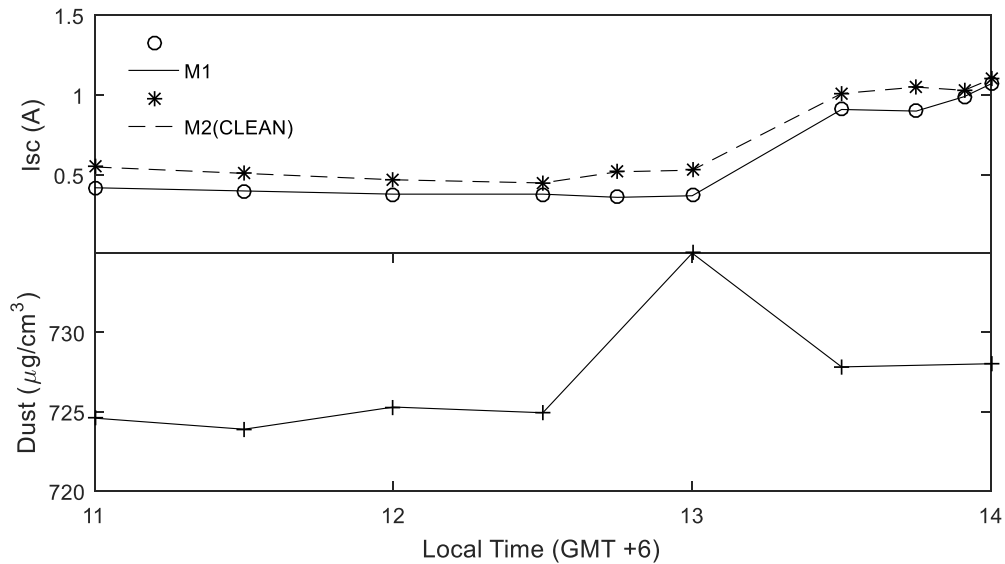

Figure 4.9: Isc and dust density VS Time at 18 July, 2019

The figure 4.9 shows data collected on 18th July 2019. The weather was mostly cloudy and at some moments there were few drops of rain at around 12:30pm. In the figure, the short circuit current is plotted for a period of three and a half an hour. The data were taken from 10:30 am till 2 pm. The short circuit readings were very low but steady. There wasn't much fluctuation in the reading readings. At 1:30 as the clouds cleared and the irradiance increased, there was an instant rise in short circuit current. For M1 the rise in readings was about 146% and for M2 it was about 90.5%. The short circuit current remained a relatively steady pattern for the rest of the time period.

If we take a look at the reading from the dust sensor for 18th July 2019, it can be observed that the dust density reading slowly increases except there is a peak reading at 1:00am

21st July, 2019:

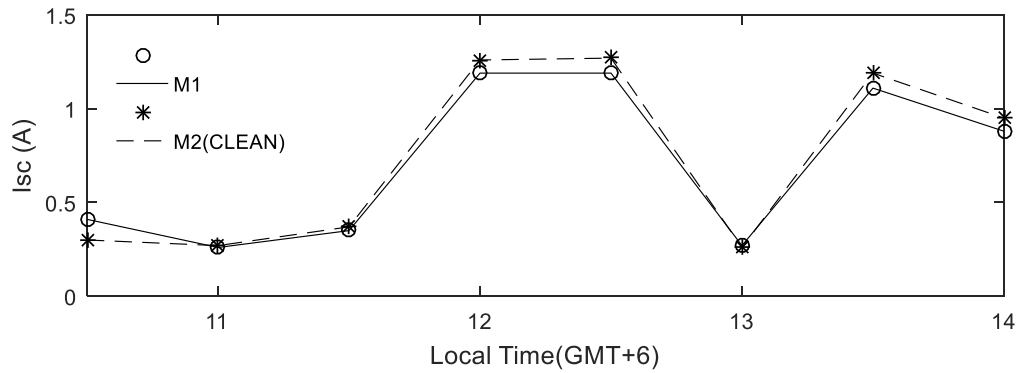

Figure. 4.10: I_{sc} VS Time at 21st July 2019

The figure 4.10 shows data collected on 21st July 2019. The weather was sometimes cloudy and sometimes sunny. The readings were collected for a period of three and a half hours. The data were taken from 10:30 am till 2 pm. From the beginning, the short circuit reading was low. However, at 12am the reading increases as the clouds cleared. The rise in short circuit current was approximately 240% for both the module. Again, short circuit current drops to a lower reading at 1:00am. Due to the spontaneity of the weather, the reading shows a pattern of fluctuation in the chosen time period.

4.4 Month wise data comparison

To have a better understanding about the effects of dust on the PV panels and come up to a conclusion, it is important to have a month wise comparison of the data for both cleaned and dirty module (M1 and M2). To have a more fair comparison, a single sunny day from the months of May, June and July is picked and the data collected were compared. The short circuit current of the modules for the date 23rd May, 12th June and 17th July is selected to be compared. The data were plotted at every half an hour interval.

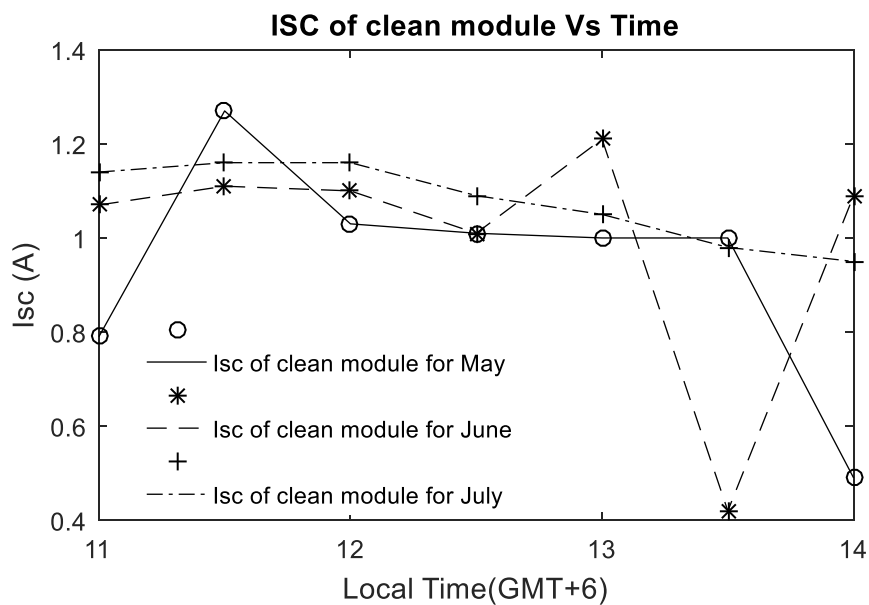

Figure 4.11: Month wise Short circuit current of clean module (M2)

In the figure above, Short circuit current readings from the clean module (M2) is shown. As the days were different, so does the weather and thus the short circuit currents for the chosen dates shows different characteristics. However, by ignoring the extreme points in that graph and having a general look at the graph, a characteristic pattern can be seen. If we ignored the fluctuation at 11:30am for the data of 23rd May, it can be concluded that the least amount of short circuit current of M2 was collected on 23rd May in comparison to other months.

Later on, we take a look at the data from 12 June. The short circuit current for a sunny day in June shows some fluctuation from 1pm - 2pm. If the readings at those points is ignored. it can be concluded that the short circuit current on 12 June is higher than the month of May but lower than the month of July.

Moreover, we focus on the readings from 12 June. The short circuit current for a sunny day in July shows less fluctuation during the whole time period. From the graph, a conclusion can be made that the short circuit current on 17 July was higher than the month of May and June.

From the figure, we observed that from May to July the short circuit current of the module M2 increases as the month progresses. It can be said that the rise in short circuit current is due to increase in irradiance. The reason for the rise in irradiance is assumed due to the position of the sun in the sky during the season of summer and Monsoon.

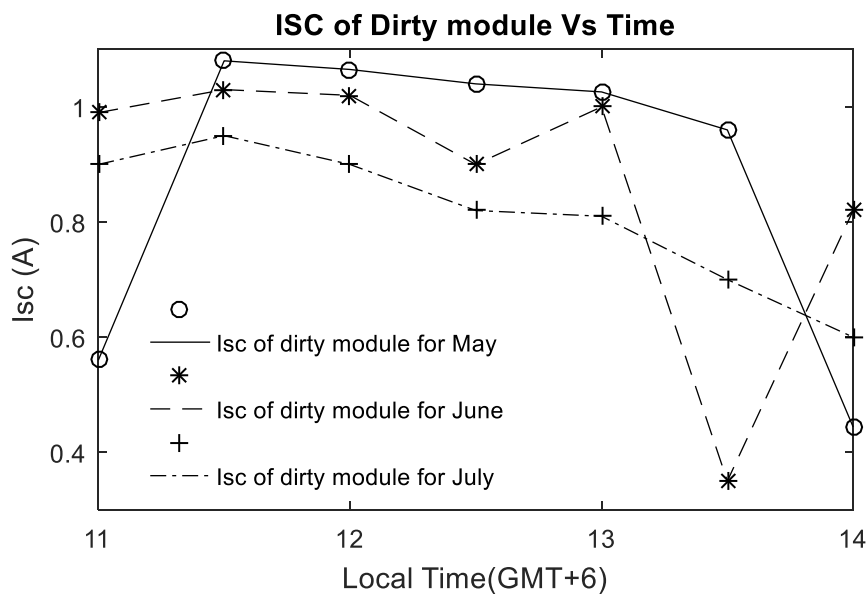

Figure 4.12: Month wise Short circuit current of dusty module (M1)

The figure 4.12 presents, short circuit current readings from the dusty module (M1) is shown. Each graph represents individual days, thus the short circuit currents for the chosen date's

shows different characteristics. However, by ignoring the fluctuating points in the graph and having a general look at the graph, a characteristic pattern can be seen. If we ignored the extreme points at 11am for the data of 23rd May, it can be concluded that the highest amount of short circuit current for M1 was collected on 23 May in comparison to other months.

Additionally, when we visually look at the data from 12 June. The short circuit current for a sunny day in June shows some fluctuation from 1pm - 2pm. If the readings at 1:30pm to 2 pm is ignored. It can be concluded that the short circuit current on 12 June is lower than the month of May but greater than the month of July.

Lastly, we focus on the data from 12th June. The short circuit current for July shows little fluctuation during the whole time frame. From the graph, we observe that the short circuit current on 17 July was lower than the other months of May and June.

4.5 Percentage Comparison:

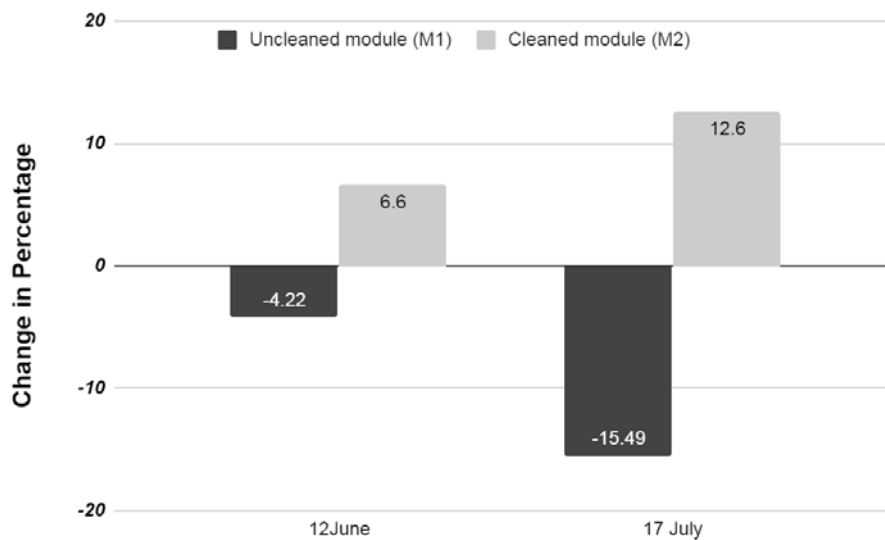

Figure 4.13: Percentage comparison of short circuit current

The figure 4.13 shows the change in percentage for both cleaned and dirty module (M2 and M1) the change in percentage is calculated for the readings of 12th June and 17th July in reference to the reading from 23rd May. For dirty module (M1), the short circuit current shows decrease in readings by 4.22% on 12th June and 15.49% on 17th July. On the other hand, the short circuit current for the cleaned module (M2) indicates an increase in readings by 6.80% on 12th June and 12.60% on 17th July.

From the figure, we observed that from May to July the short circuit current of the cleaned module M2 increases as the month progresses. The reason due to this increase is considered due to the increase in irradiance. Moreover, by distinguishing the short circuit current reading for the dusty module (M1) from May to July, the short circuit current of the module M1 decreases as the month progresses. Thus, it can be concluded that the drop in short circuit current is due to an increase in dust accumulation as the dust was the only factor that was controlled in this experiment. As dust accumulation on the dusty module (M1) increased, the short circuit current for the module (M1) also decreases.

Chapter: 05

Conclusions

This paper focuses on the impact of dust accumulation that reduces the short circuit current of a photovoltaic module that has been investigated from April to July 2019 in Dhaka, Bangladesh. Results show that both the cloud cover and the dust accumulation onto the surface of the solar module have a great impact on PV solar performance. The effect of dust accumulation has a long-term effect. The overall analysis has been illustrated by experimental data which have been collected under outdoor environmental conditions. The dust increases the temperature of the affected cells, decreases the irradiance thus affects the output parameter.

In the study, it has been also shown that the relative differences in PV module performance parameters between the cases where the modules were dusty and the cases where they are cleaned can be higher under the same environmental condition. In this study we have seen that the short circuit current of clean module shows increasing values in June and July with respect to May. It shows increase in short circuit current 6.6% in 12th June and 12.6 % in 17th July with respect to 23rd May. On the other hand dusty module over this three months shows 4.22% decrease in short circuit current in 12th June and 15.49% in 17th July with respect to the short circuit current of 23rd May. The irradiation increases from the month of May to July as well as the short circuit current of clean module. But dust can affect the module which shows decrease in short circuit current.

For the dust accumulation effect, it reflects the incoming solar radiation reaching the solar module resulting hence to decrease the energy output of the module. So it is very worthy to clean the module every day in order to minimize the loss due to dust accumulation especially in a dusty environment. In perspective, this study should be conducted further to perform the

effect of dust with different types of cell technologies in order to see which of these technologies is more suitable for the area of study. We highly recommend also perform the measurement for all the months in order to know in which of the months the module is more affected by dust accumulation. Also perform the measurements at different geographical points might improve the results of this work. It is expected that this study is going to be highly beneficial for design engineers responsible for PV system design and implementation.

Future works

Present work focuses on the effect of dust mostly during summer season. Future work would focus on the effect of dust in different seasons, for the whole year. In the future dust impact can also be analyzed at different elevations and different locations. Dust mapping on the surface of PV module can also be studied to get a better understanding on the pattern of dust accumulation. A comprehensive cleaning plan and procedure should be developed to optimize module output.

References

- [1] “The structure of a photovoltaic module: ECOPROGETTI - Specialist in photovoltaic production process,” Ecoprogetti, 16-Feb-2017. [Online]. Available: <https://ecoprogetti.com/the-structure-of-photovoltaic-module/>. [Accessed: 28-Aug-2019].
- [2] “How PV Panels Work: Photovoltaic Lighting: Lighting Answers: NLPIP,” How PV Panels Work | Photovoltaic Lighting | Lighting Answers | NLPIP. [Online]. Available: <https://www.lrc.rpi.edu/programs/nlpip/lightinganswers/photovoltaic/04-photovoltaic-panels-work.asp>. [Accessed: 28-Aug-2019].
- [3] Evaluation and Validation of Equivalent Circuit Photovoltaic Solar Cell Performance Models - Scientific Figure on ResearchGate. Available from: https://www.researchgate.net/figure/An-equivalent-electrical-circuit-used-to-model-a-PV-cell_fig7_301674613 [accessed 22 Aug, 2019]
- [4] Boyd, Matthew. (2010). Evaluation and Validation of Equivalent Circuit Photovoltaic Solar Cell Performance Models. 10.13140/RG.2.1.2603.5605.
- [5] Bhowmik, Himangshu& Amin, Ruhul. (2019). Performance Analysis of PV Cells under Monsoon Climate. 10.1750/683.
- [6] Singh, Jasvir. (2013). A Review on Solar PV Cell. International Journal of Innovative Technology and Exploring Engineering.
- [7] TABREZ MANSOORALI DAYA, “DEVELOPING THE NEXT GENERATION OF SOLAR LANTERN”. The University of Nottingham.
- [8] Casanova &Piliougiue, Carretero&Dernaola, Carpena& Mora- Lopez. (2011). Analysis of dust losses in photovoltaic modules. World Renewable Energy Congree 2011- Sweden.

- [9] Zdanowicz T, Rodziewicz T and Waclawek Z M, "Evaluation of Actual PV Modules Performance at Low Insolation Conditions", Wroctaw University of Technology, Institute of Microsystem Technology Solar 764-767, 1997. Lab, OPTO-Electronics Review, Vol.9, No.4, PP.361-366, 2001.
- [10] Johan W, PhD Thesis, "Design and Stability of Cu (In, Ga) Se₂-Based Solar Cell Performance", Angstrom Solar Centre, Uppsala University.
- [11] Sharpsensoruser, "sharpsensoruser/sharp-sensor-demos," GitHub. [Online]. Available: <https://github.com/sharpsensoruser/sharp-sensor-demos/wiki/Application-Guide-for-Sharp-GP2Y1014AU0F-Dust-Sensor>. [Accessed: 28-Aug-2019].
- [12] "Dust Sensor (Waveshare) Sharp GP2Y1010AU0F," RLX COMPONENTS s.r.o. Electronic Components Distributor. [Online]. Available: <https://rlx.sk/en/senzory/4649-dust-sensor-waveshare-sharp-gp2y1010au0f.html>. [Accessed: 28-Aug-2019].
- [13] "Arduino Dust sensor example," Arduino learning, 13-Oct-2016. [Online]. Available: <http://arduinolearning.com/code/arduino-dust-sensor-example.php>. [Accessed: 28-Aug-2019].
- [14] [Online]. Available: <http://www.atmel.com/>. [Accessed: 28-Aug-2019].
- [15] Chetan Singh Solanki, RENEWABLE ENERGY TECHNOLOGIES: A Practical Guide for Beginners, 3rd edition, PHI Learning private limited, October 2009
- [16] Darwish, Zeki. (2013). Effect of Dust on Photovoltaic Performance Review and Research Status. 10.13140/2.1.4527.9523
- [17] Zorrilla-Casanova, "Analysis of dust losses in photovoltaic modules," World Renewable Energy Congress 2011, Sweden, 2011

- [18] A. Sulaiman, "Effects of Dust on the Performance of PV Panels," World Academy of Science, Engineering and Technology, 2011.
- [19] Nahar Nipu, "Effect of accumulated dust on the performance," International Journal of Engineering & Technology, 2016.
- [20] A. Hussain, "An experimental study on effect of dust," Renewables, 2017.
- [21] M. Rahman, "Effects of Natural Dust on the Performance of PV," I.J.Modern Education and Computer Science, 2012.
- [22] R. Appels a, "Effect of soiling on photovoltaic modules," Solar Energy, 2013.
- [23] Benjamin Figgis, "Time-of-day and Exposure Influences on PV Soiling," IEEE, 2017.
- [24] M. Piliougin¹, "COMPARATIVE ANALYSIS OF THE DUST LOSSES IN PHOTOVOLTAIC," 23rd European Photovoltaic Solar Energy Conference and Exhibition, Valencia, 2008.
- [25] Ngan MS. Tan CW, A study of maximum power point tracking algorithms for stand-alone photovoltaic systems. In Applied Power Electronics Colloquium (IAPEC). 2011 IEEE; 2011. p. 22–27.
- [26] Sheraz M, Abido MA, An efficient MPPT controller using differential evolution and neural network. In: Proceedings of IEEE International Conference on Power and Energy; 2012. p. 378–383.

Appendix A.

Mat lab code of Day wise data analysis

```
%9th May 2019/Isc vs time
```

```
subplot(2,1,1);
```

```
T=[12 12.25 12.50 12.75 13 13.16 13.33 13.50 13.66 13.83 14 14.16 14.33 14.50 14.66 14.83  
15];
```

```
Isc=[1.07 1.07 1.03 1.04 1.02 1 1.03 .99 .97 .63 .9 .84 .8 .68 .76 .72 .73];%m1
```

```
Isc2=[1.18 1.14 1.08 1.12 1.07 1.06 1.07 1.05 1.047 .79 .95 .9 .62 .61 .79 .74 .75];%m2
```

```
plot(T,Isc,'blacko',T,Isc,'black-')
```

```
hold on
```

```
plot (T,Isc2,'black*',T,Isc2,'black--')
```

```
hold on
```

```
title('ISC Vs Time')
```

```
xlabel('Local Time(GMT+6)')
```

```
ylabel('Isc (A)')
```

```
legend({'','M1','','M2(CLEAN)'},'Location','southwest')
```

```
subplot(2,1,2);
```

```
T=[12 12.25 12.50 12.75 13 13.16 13.33 13.50 13.66 13.83 14 14.16 14.33 14.50 14.66 14.83  
15];
```

```
D=[736.54 734.96 732.95 738.17 729.50 727.87 730.82 734.94 748.84 741.04 742.09 741.46  
740.72 744.08 743.19 735.22 740.06 ];
```

```
p = polyfit(T,D,1);
```

```
plot(T,D,'black+',T,D,'black-')
```

```
hold on
```

```
title('Dust Vs Time')
```

```
xlabel('Time')
```

```
ylabel('Dust')
```

```
legend({'Dust density(ug/cm3)'},'Location','northwest')
```

```

%14th May 2019/Isc vs time

subplot(2,1,1);

T=[10.50 10.75 11 11.25 11.50 11.75 12 12.25 12.50 12.75 13 13.25 13.50 13.75 14 14.25
14.50 14.75 15 ];

Isc=[.89 .94 .96 1 .96 .96 1.01 .33 .94 .42 .7 1.12 .66 1.01 .35 1.04 .73 .37 .63 ];%m1

Isc2=[1.03 1.107 1.134 1.167 1.130 1.162 1.178 .57 1.224 .76 1.03 .46 1.11 1.18 .57 .67 .96
.18 .87];%m2

plot(T,Isc,'blacko',T,Isc,'black-')

hold on

plot (T,Isc2,'black*',T,Isc2,'black--')

hold on

title('ISC Vs Time')

xlabel('Local Time(GMT+6)')

ylabel('Isc (A)')

legend({'','M1','','M2(CLEAN)'},'Location','southwest')

subplot(2,1,2);

T=[10.50 10.75 11 11.25 11.50 11.75 12 12.25 12.50 12.75 13 13.25 13.50 13.75 14 14.25
14.50 14.75 15];

D=[749.21 745.29 748.05 744.4 742.35 738.26 743.5 742.62 743.62 746.28 739.86 741.88
744.74 745.33 744.66 743.52 745 745.46 744.67];

plot(T,D,'black+',T,D,'black-')

hold on

title('Dust Vs Time')

xlabel('Time')

ylabel('Dust')

legend({'Dust density(ug/cm3)'},'Location','northwest')

```

```

%23rd May 2019/Isc vs time

subplot(2,1,1);

T=[10.50 10.75 11 11.25 11.50 11.75 12 12.25 12.50 12.75 13 13.50 13.75 14 14.25 14.50
14.75 15 ];

Isc=[0.96 1.03 .56 1.07 1.08 .59 1.065 1.03 1.04 1.05 1.026 .96 .892 .444 .67 .561 .82 .68
];%m1

Isc2=[1.27 1.25 .79 1.29 1.27 .79 1.03 1.01 1.01 1 1 1 .93 .49 .8 .56 .88 .69];%m2

plot(T,Isc,'blacko',T,Isc,'black-')

hold on

plot (T,Isc2,'black*',T,Isc2,'black--')

hold on

title('ISC Vs Time')

xlabel('Local Time(GMT+6)')

ylabel('Isc (A)')

legend({'','M1','','M2(CLEAN)'},'Location','northeast')

subplot(2,1,2);

T=[10.50 10.75 11 11.25 11.50 11.75 12 12.50 12.75 13 13.75 14 14.25 14.50 14.75 15];

D=[753 753.3 754.63 753.75 751.16 748.42 749.14 751.48 748.46 751.73 752.39 754.55
753.13 753.75 752.45 750.6];

plot(T,D,'black+',T,D,'black-')

hold on

title('Dust Vs Time')

xlabel('Time')

ylabel('Dust')

legend({'Dust density(ug/cm3)'},'Location','northwest')

```

```

%12th June 2019/Isc vs time

subplot(2,1,1);

T=[10.50 11 11.50 12 12.50 13 13.50 14 14.50];

Isc=[.89 .99 1.03 1.02 .9 1 .35 .82 1 ];%m1

```

```

Isc2=[.96 1.07 1.11 1.10 1.01 1.21 .42 1.09 1.10];%m2
plot(T,Isc,'blacko',T,Isc,'black-')
hold on
plot (T,Isc2,'black*',T,Isc2,'black--')
hold on
title('ISC Vs Time')
xlabel('Local Time(GMT+6)')
ylabel('Isc (A)')
legend({'M1','M2(CLEAN)'},'Location','southwest')
subplot(2,1,2);
T=[ 10.50 11 11.50 12 12.50 13 13.50 14 14.50 ];
D=[742.6 739.89 740.53 747.93 748.4 746.3 750.03 749.34 748.6];
plot(T,D,'black+',T,D,'black-')
hold on
title('Dust Vs Time')
xlabel('Time')
ylabel('Dust')
legend({'Dust density(ug/cm3)'},'Location','northwest')

```

```

%20th June 2019/Isc vs time
T=[10.50 11 11.50 12 12.50 13 13.50 14];
Isc=[1.03 .97 .67 .84 1.10 .72 .75 .68 ];%m1
Isc2=[1.11 1.05 .72 .92 1.17 .7 .8 .69];%m2
plot(T,Isc,'blacko',T,Isc,'black-')
hold on
plot (T,Isc2,'black*',T,Isc2,'black--')
hold on
title('ISC Vs Time')
xlabel('Local Time(GMT+6)')

```

```

ylabel('Isc (A)')
legend({'','M1','','M2(CLEAN)'},'Location','northeast')

%10th July 2019/Isc vs time
T=[10.50 10.75 11 11.25 11.50 11.75 12 12.25 12.50 12.75 13];
Isc=[.35 .33 .49 .55 .56 .46 .36 .38 .40 .35 .37 ];%m1
Isc2=[.37 .35 .54 .59 .60 .49 .40 .41 .43 .42 .41];%m2
plot(T,Isc,'blacko',T,Isc,'black- ')
hold on
plot (T,Isc2,'black*',T,Isc2,'black--')
hold on
title('ISC Vs Time')
xlabel('Local Time(GMT+6)')
ylabel('Isc (A)')
legend({'','M1','','M2(CLEAN)'},'Location','northwest')

```

```

%17 July 2019/Isc vs time
T=[11 11.25 11.50 11.75 12.0 12.25 12.50 12.75 13.25 13.75 14 ];
Isc=[0.9 .28 .95 .91 .90 .44 .82 .79 .81 .69 .60 ];%m1
Isc2=[1.14 .45 1.16 1.16 1.16 .69 1.09 1.05 1.05 .98 .95];%m2
plot(T,Isc,'blacko',T,Isc,'black-')
hold on
plot (T,Isc2,'black*',T,Isc2,'black--')
hold on
title('ISC Vs Time')
xlabel('Local Time(GMT+6)')
ylabel('Isc (A)')
legend({'','M1','','M2(CLEAN)'},'Location','southeast')

```

```

%18th July 2019/Isc vs time
subplot(2,1,1);
T=[11 11.50 12 12.50 12.75 13 13.50 13.75 13.91 14];
Isc=[.42 .4 .38 .38 .36 .37 .91 .9 .99 1.07 ];%m1
Isc2=[.55 .51 .47 .45 .52 .53 1.01 1.05 1.03 1.1];%m2
plot(T,Isc,'blacko',T,Isc,'black-')
hold on
plot (T,Isc2,'black*',T,Isc2,'black--')
hold on
title('ISC Vs Time')
xlabel('Local Time(GMT+6)')
ylabel('Isc (A)')
legend({'','M1','','M2(CLEAN)'},'Location','northwest')
subplot(2,1,2);
T=[11 11.50 12 12.50 13 13.50 14 ];
D=[724.6 723.9 725.3 724.94 735 727.83 728.03];
plot(T,D,'black+',T,D,'black-')
hold on
title('Dust Vs Time')
xlabel('Time')
ylabel('Dust')
legend({'Dust density(ug/cm3)'},'Location','northwest')

```

```

%21st July 2019/Isc vs time
T=[10.50 11 11.50 12 12.50 13 13.50 14];
Isc=[.41 .26 .35 1.19 1.19 .27 1.11 .88 ];%m1
Isc2=[.3 .27 .37 1.26 1.27 .26 1.19 .95];%m2
plot(T,Isc,'blacko',T,Isc,'black-')
hold on
plot (T,Isc2,'black*',T,Isc2,'black--')

```

```

hold on
title('ISC Vs Time')
xlabel('Local Time(GMT+6)')
ylabel('Isc (A)')
legend({'M1','M2(CLEAN)'},'Location','northwest')

```

Mat Lab of Month wise data

Clean module

```

T=[11 11.50 12 12.50 13 13.50 14];
Isca=[.79 1.27 1.03 1.01 1 1 .49 ];%m2may14
Iscb=[1.07 1.11 1.10 1.01 1.21 .42 1.09 ];%m2june
Iscc=[1.14 1.16 1.16 1.09 1.05 .98 .95];%m2july17
plot(T,Isca,'blacko',T,Isca,'black-')
hold on
plot(T,Iscb,'black*',T,Iscb,'black--')
hold on
plot (T,Iscc,'black+',T,Iscc,'black-.')
hold on
title('ISC of clean module Vs Time')
xlabel('Local Time(GMT+6)')
ylabel('Isc (AMPERE)')
legend({'Isc of clean module for May','Isc of clean module for June','Isc of clean module for July'},'Location','southwest')

```

Dirty module

```

T=[11 11.50 12 12.50 13 13.50 14 ];
Isca=[.56 1.08 1.065 1.04 1.026 .96 .444];%13may
Iscb=[.99 1.03 1.02 .9 1 .35 .82];%12june
Iscc=[0.9 .95 .90 .82 .81 .70 .60 ];%july17

```



```

plot(T,Isca,'blacko',T,Isca,'black-')
hold on
plot(T,Isca,'black*',T,Isca,'black--')
hold on
plot (T,Isca,'black+',T,Isca,'black-.')
hold on
title('ISC of Dirty module Vs Time')
xlabel('Local Time(GMT+6)')
ylabel('Isc (A)')
legend({'','Isc of dirty module for May','Isc of dirty module for June','Isc of dirty module
for July'},'Location','southwest')

```

Mat lab code for I-V curve of PV module

```

% Date 02/05/2019
I=[1.25 1.26 1.25 1.04 .76 .63 .52 .40 .31 .33 .28 .25 .24 .21 0];
V=[0 .8 3.3 13.06 17.37 18.63 19.03 19.33 19.52 19.58 19.67 19.78 19.85 19.89 19.92 20.2];
plot(V,I,'r')%M1
hold on;
I2=[1.3 1.28 1.07 .74 .59 .52 .47 .40 .35 .32 .3 .28 0];
V2=[0.7 7.9 6.7 18.3 18.9 19.18 19.32 19.39 19.18 19.23 19.34 19.53 20.16 ];
plot(Vm,Im,'b')%M2
hold on;

```