

# **A Comparative Study of Power Sources for Base Transceiver Station**



MD. PAVEL MAHBUB	-	13121144
SYED MINHAJUL ABEDIN	-	12121158
SARWAR ALI ARMAN	-	12121061
MD. MAHMUDUR RAHMAN	-	12221092

Supervisor

**DR. AMITABHA CHAKRABARTY**

Co-Supervisor

**DR. SAIFUR RAHMAN SABUJ**

**Department of Electrical and Electronic Engineering,  
BRAC University**

## DECLARATION

We, hereby, declare that the research work titled “*A Comparative Study of Power Sources for Base Transceiver Station*” is our own work and we solemnly declare that to the best of our knowledge, no part of this research have been submitted here or elsewhere in a previous application for award of a degree. All sources of knowledge have been duly acknowledged.

Date: 04/09/2018

---

Dr. Amitabha Chakrabarty  
Supervisor

Signature of Authors

---

Md. Pavel Mahbub  
ID: 13121144

---

Dr. Saifur Rahman Sabuj  
Co-Supervisor

---

Syed Minhajul Abedin  
ID: 12121158

---

Sarwar Ali Arman  
ID: 12121061

---

Md. Mahmudur Rahman  
ID: 12221092

## **ACKNOWLEDGEMENT**

We are grateful to our supervisor Dr. Amitabha Chakrabarty, Department of Computer Science & Engineering (BRAC University) and co-supervisor Dr. Saifur Rahman Sabuj, Department of Electrical and Electronic Engineering (BRAC University); for the enormous support and guidance throughout the period. Without their effort and support, this would not have been possible. Thanks to all the individual, without whose contribution this research would not be a success.

## **ABSTRACT**

Base Transceiver Station is considered as the heart of mobile telecommunication system. Millions of phone calls, SMS and enormous number of data is being sent and received in every second through these BTS all over the world. Therefore, BTS are the devices which need to run 24/7 without being disturbed by any sort of electric crisis or shortage. Bangladesh is not fully compatible to meet the growing electricity demand of the whole country. Although it varies from day to day, on an average we predicted there are two hours of load shedding period in every distribution line of entire country. Therefore, it requires 24/7 electricity supply to all the BTS of all operators. Our concern is during the off grid period. It is found that all the operators use diesel generators for the off grid time. Our target is to compare the feasibility of using alternative power sources to minimize the cost of the system, minimizing carbon emission and reducing the dependency on the fossil fuel. Firstly, we have analyzed the previous and recent data of diesel, solar and fuel cell power sources. A new we model is proposed to combine the sources with backup of diesel generator which can minimize the cost and fulfill our target. We also analyzed the future of carbon emission which our proposed model can reduce after a certain period of years.

## **List of tables**

Table 2.1: Panel area based on KW system.....	14
Table 5.1: Approximate diesel fuel consumption.....	41

## List of Figures

Fig 2.1: Energy reservation and future ending.....	7
Fig 2.2: Crude oil price over the years in different region.....	8
Fig: 2.3: The growing gap of regular conventional oil.....	9
Fig 2.4: The rate of changing of diesel price in Bangladesh.....	10
Fig 2.5: Cell efficiency development in research.....	12
Fig 2.6: Decline rate of price for solar PV (\$/watt) and annual installed Solar PV capacity (MWDC).....	13
Fig 2.7: PEM stack price declining.....	16
Fig 2.8: PEM fuel cell system cost declining in terms of manufacturing.....	17
Fig 3.1: Flowchart of the proposed model.....	19
Fig 3.2: Proposed design of the system.....	20
Fig 4.1: Diesel generator system cost over the years (2018 – 2032).....	24
Fig 4.2: Solar panel system cost over the years (2018 – 2032).....	27
Fig 4.3: Fuel cell generator full cost over the years (2018 – 2032).....	30
Fig 4.4: Comparison between diesel generator, solar panel and fuel cell energy (2018 – 2032).....	32
Fig 4.5: Period VS system cost yearly (On average of 15 years).....	33

Fig 4.6: Cost per year for proposed model VS diesel generator cost per year  
(2018 – 2032)..... 35

Fig 4.7: Solar cell cost VS generator cost (2018 – 2032)..... 36

Fig 4.8: Proposed system cost VS diesel generator (2018 – 2032)..... 37

Fig 5.1: Diesel generator, polluting environment..... 39

Fig 5.2: Temperature anomaly graph..... 40

Fig 5.3: Bangladesh CO2 emission per capita graph..... 43

## Table of Contents

DECLARATION.....	i
ACKNOWLEDGEMENT.....	ii
ABSTRACT.....	iii
List of tables.....	iv
List of figures.....	v
CHAPTER 01: INTRODUCTION.....	1
1.1 Motivation.....	1
1.2 Thesis contribution.....	1
1.2.1 Problem statement.....	2
1.2.2 Solution.....	2
1.2.3 Methodology.....	3
1.3 Summary of contribution.....	3
1.4 Outline of the thesis.....	4
CHAPTER 02: LITERATURE REVIEW.....	5
2.1 BTS of Bangladesh.....	5
2.2 BTS requirement and traditional power supply.....	5



2.3 Recent condition and future of fossil fuel.....	7
2.4 Solar cell (Recent and near future).....	11
2.5 Fuel cell (Recent and near future).....	14
CHAPTER 03: POPOSED MODEL AND DESIGNING.....	18
3.1 Proposed model.....	18
3.2 Design.....	19
3.3 Advantages of the proposed model.....	21
CHAPTER 04: MATHEMATICAL MODEL.....	22
4.1 Diesel generator output.....	23
4.2 Solar panel output.....	25
4.3 Fuel cell output.....	28
4.4 Comparison and proposed model output.....	31
CHAPTER 05: GREEN ENERGY.....	38
5.1 Emission of CO <sub>2</sub> .....	38
5.2 Why green energy? .....	39
5.3 CO <sub>2</sub> emission by diesel fuel.....	41
5.4 Comparison in terms of Bangladesh.....	42

CHAPTER 06: CONCLUSION.....	46
6.1 Summary.....	46
6.2 Drawbacks and possible recovery of the proposed model.....	46
6.3 Future works.....	47
REFERENCES.....	48
APPENDIX.....	53

# CHAPTER 1

## INTRODUCTION

### 1.1 Motivation

Base Transceiver Stations are the core of the mobile telecommunication system which require full time uninterrupted power supply to keep the network alive. Hamper or disconnection for even small period of time can break down the network of that certain area. But in the perspective of Bangladesh, it is not possible to supply full time electricity from the central grid line. Based on the recent studies which show that on average two hours of load shedding happens in every line throughout the country. Although it varies from place to place, even in some areas it increases up to six or seven hours in a single day, which clearly shows the power shortage in the central generation areas. As BTS needs full time electricity supply, back up source is a must. In Bangladesh, almost all the BTS are run by diesel generator as backup which requires huge number of fuel per year.

### 1.2 Thesis contribution

Based on the ongoing system, we focused on the drawbacks of the system along with tried to visualize the possible solution. Along with that our analyzed data and possible proposed model shows the contribution of our work in decreasing cost of the system.

### **1.2.1 Problem statement**

As the study shows that the price of the diesel is increasing in an alarming rate day by day as the reserved fossil fuel will be finished within this century. Along with that, diesel generators are increasing the number of CO<sub>2</sub> in the air which is getting severe day by day. One of the main drawbacks of the diesel generator is the increase of diesel price day by day because of the shortage of fossil fuel all over the world. The increasing percentage is pretty high. Along with that, older the generator gets, more the diesel requirement increases over the years. Therefore, the diesel generators produce a huge number of carbon di oxide which is added to the environment every day. That is why, in near future we need to stop our dependency on the diesel generators, rather need to look for alternative solution.

### **1.2.2 Solution**

That is why, it is high time we should give emphasize on the alternative sources of energy. The aim of this research is to show a comparison between traditional back up source and alternative sources mostly renewable, for the Base Transceiver Stations. A comparison study in between two renewable energy sources are presented here, as the user or company will have their own preference to choose one or can add other sources in the system as well.

Renewable energy, which is often termed as green energy, is energy which can be produced and replaced by natural resources. They are much better for the environment and produce less carbon di oxide than regular energy sources. For example: Hydro power, Solar, Fuel cell, Biomass, Wind, Geothermal etc. Among all of them, few of them can be used in BTS. In our proposed

design we are analyzing solar and fuel cell along with the regular diesel generator for the BTS. Because wind energy is expensive to establish and is not for small system, which requires huge place and sufficient wind supply to produce electricity. Besides, rests of the alternative energy sources are also not perfect for running single BTS. Here we need such source which is cost effective and installable for each BTS and we have chosen solar and fuel cell. Cause others may require huge number of area or huge amount of budget which will not be beneficial for the operators to use.

### **1.2.3 Methodology**

Our research is basically a statistical data analysis and combination of them to compare with the ongoing system and providing possible solution. As in near future, all must move on to renewable energy anyway, we tried to provide the possible data required to choose the best solution. On the probability and graphs of previous year's data sheets, we tried to propose a model which may come handy in using the alternative sources of energy.

### **1.3 Summary of contribution**

The focus of the research is to show why we should emphasize on the renewable energy sources instead of fossil fuel. If the system runs in diesel as well as same system runs in alternative energy, second one shows better outcome in terms of cost and efficiency.

## 1.4 Outline of the thesis

- Chapter 2 provides the literature review which includes the recent and future condition of fossil fuel, solar and fuel cell.
- Chapter 3 describes our proposed design, flowchart and how does it work along with advantages of the model.
- Chapter 4 shows our results, graphs and mathematical calculations of the final outcome which includes all the comparison data analysis as well.
- Chapter 5 provides the data analysis of CO<sub>2</sub> emission and also shows how our proposed model can reduce the amount in the environment.
- Chapter 6 concludes the discussion along with possible improvement areas and also the drawbacks and possible solutions.

## **CHAPTER 2**

### **LITERATURE REVIEW**

As already mentioned, we are analyzing the data of fossil fuel along with that comparing the data with solar and fuel cell energy. Based on the past and present research on these all three sources, we have planned our model. Before going to the model all the research works on this field are important to analyze to get a fruitful solution.

#### **2.1 BTS of Bangladesh**

In this research, we have analyzed the data on the base transceiver stations (BTS) of whole Bangladesh. Currently there are four mobile operators in the country and they are having 150.945 million subscribers [1] in total. Currently, there are 37,287 BTS of different operators throughout the country. Among them Grameenphone has 10000 [2], Banglalink has 9000 [3], Robi-Airtel has 14487 [4] and Teletalk is at the bottom of the list with 3800 [5] BTS. The number varied from region to region on the base of demand. These four operators run all the BTS and other service providers also use their BTS on rent for space.

#### **2.2 BTS requirement and traditional power supply**

Basically all the BTS are run by grid current and during the load shedding period operators use diesel generators to run the BTS. Normally per BTS require 22398.57 KW of energy annually,

according to the paper [6]. That means each BTS needs 2.56 KW per hour. Total power and energy consumption of the main BTS consists of some parts. Based on [7], total consumption can be represented as:

$$P_{bts} = P_{dp} + P_{ampl} + P_{ru} + P_{cov} + \sum P_{ac} + \sum P_{lb}$$

$$E_{bts} = P_{bts} \cdot t$$

Where,

$P_{bts}$ = Total Power of BTS

$E_{bts}$ =Energy Consumed

$t$  = Operating Time

$P_{dp}$ = Power of Digital Signal Processing

$P_{ampl}$ = Power of Amplifier

$P_{ru}$ = Power of Radio Unit

$P_{cov}$ = Power of AC/DC Converter

$\sum P_{ac}$ =Power of Total Air Conditioner

$\sum P_{lb}$ = Power of Lamp

The radiofrequency equipment (power amplifier along with the transceivers and cables) consumes the largest amount of energy which is nearly 65% of the total energy. Besides other components of the base station, major energy consumers are digital signal processor (10%), air conditioning (17.5%) and the AC/DC converter (7.5%).

As a developing country, Bangladesh has not been able to meet the 100% demand of electricity.

As a result, annual reports reflect the minimum two hours of load shedding in every line on



average. If we calculate only this load-shedding period, the required power for per BTS is 5.11 KW per day. So we need backup plan for this amount of energy. All the operators are using diesel generators for this period of time as backup solution.

### 2.3 Recent condition and future of fossil fuel

Fossil fuel refers to the natural resources like coal, petroleum, gas etc. which are not unlimited in number. The use of preserved fossil fuel has increased so drastically since the invention that it is on the way to get finished in near future. According to [8], in last 200 years, the use of fossil fuel has increased dramatically and put serious impact on the environment.

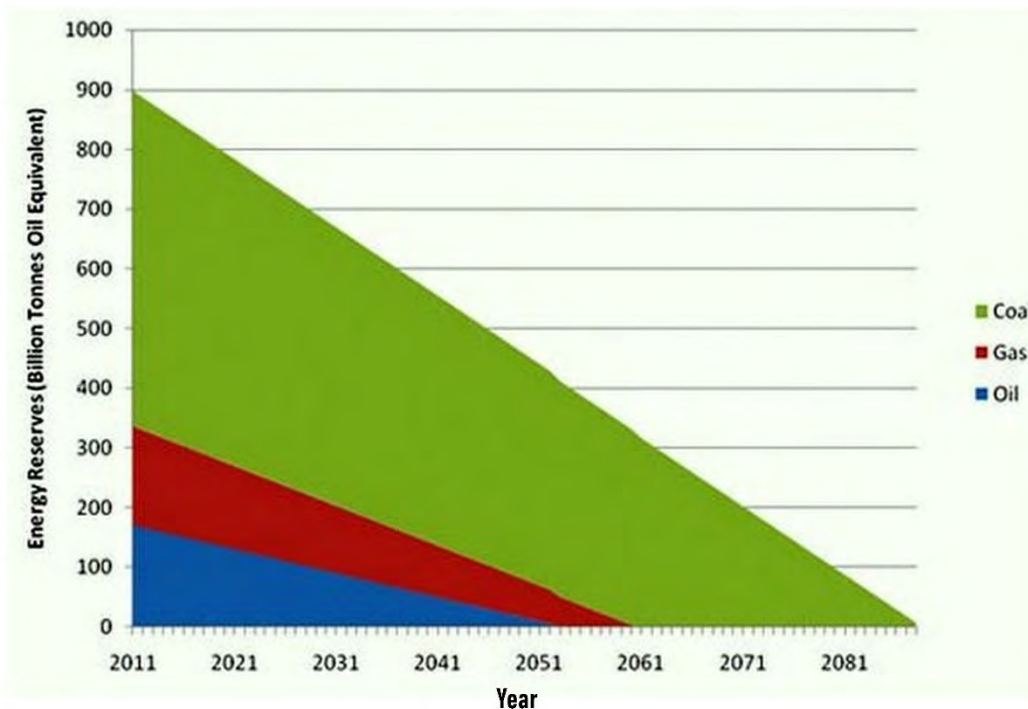

Fig 2.1: Energy reservation and future ending [8].

The above graph shows that the crude oil is going to be ended within 2052 if the rate of consumption remains the same. On the basis of BP global report 2016 [9], the rate of

consumption vs. production shows the clear scenario of decreasing of crude oil. Moreover, also the price of crude oil variation in different region reflects the increasing of price over the years.

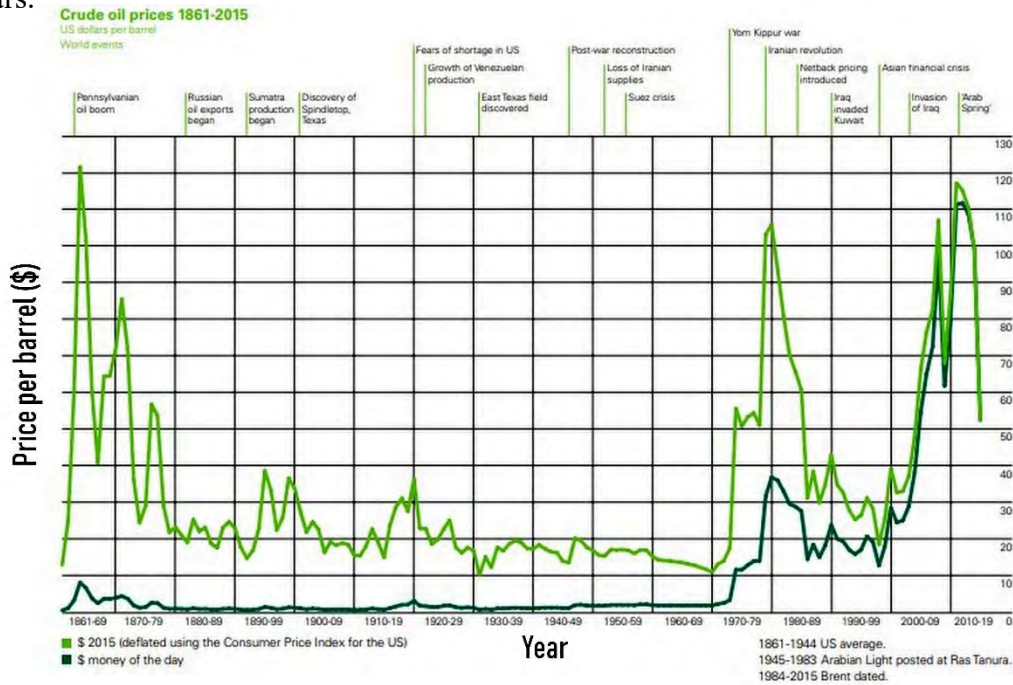

Fig 2.2: Crude oil price over the years in different region [9].

Another study of [10] indicates the inversely proportional relationship between growing demand of crude oil and the production rate over the years where the above statement has been proved that within 2052 the world will be out of reserved crude oil. As a result, definitely the necessity of alternative sources will rise.

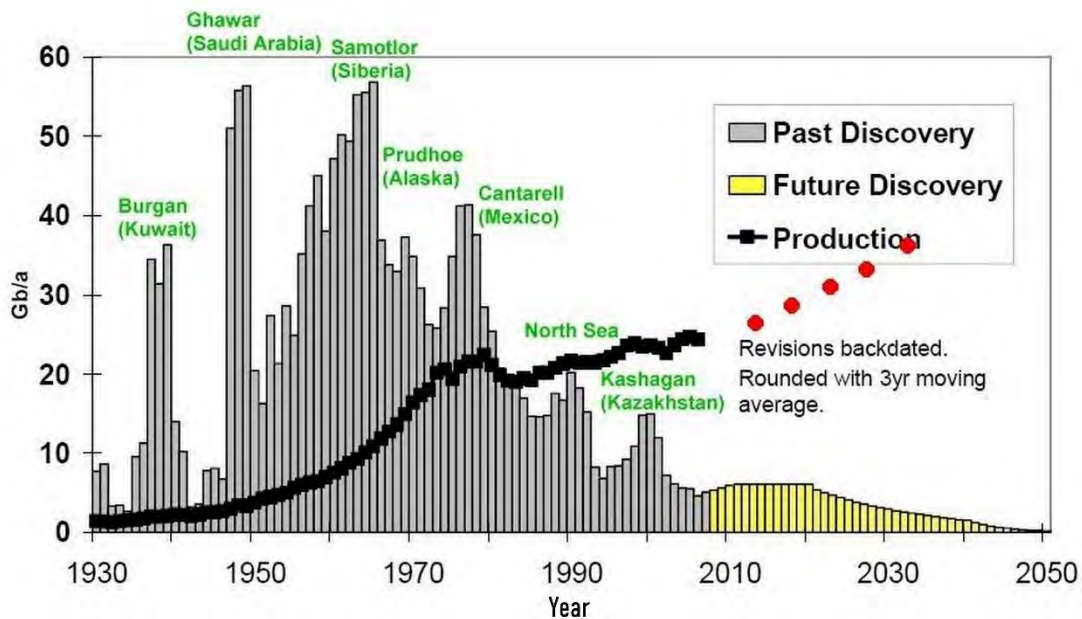

Fig: 2.3: The growing gap of regular conventional oil [10].

\*\*\* The red dotes are the rising demand

\*\*\* Yellow lines shows the future production rate of crude oil

Now if we consider the prices of diesel in Bangladesh over the past years, the graphs will also help us to predict the future data. According to [11], in 2018 the diesel price in Bangladesh in 0.77\$ per liter which is equivalent to 65 taka. Referring to [12], this price was 0.3\$ (25 taka) in 1996. From the graph, mentioned below reflects the increasing rate. On an average, the diesel price is increasing 1.81% per year in Bangladesh. From where, it can be predicted that in 2032 means after 15 years from now, the price will be 1.06\$ (90 taka) per liter or even higher as we already the reduction rate of crude oil in nature is higher than any time before and there is hardly any hope to reverse the scenario.

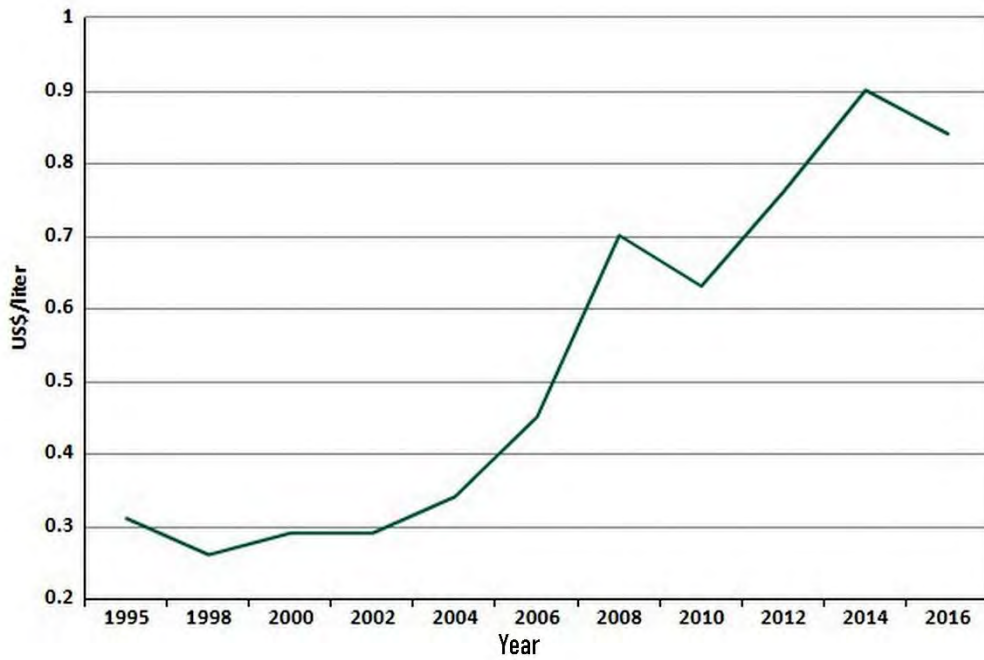

Fig 2.4: The rate of changing of diesel price in Bangladesh [12].

To add with that, if this is the scenario, in 2050 it can be predicted that the diesel price will be 123 taka per liter which is more than double of today's price.

The above data analysis clearly shows why we must look forward to alternative source of energies before the crisis hit badly in the economy.

## **2.4 Solar cell (Recent and near future)**

Solar cell has been the most efficient form of renewable energy after being developed day by day. Photovoltaic module which is often addressed as solar module is the major part of the system which produces electricity by converting the sun light. These modules are mainly made with silicon crystals and they are arranged layer by layer on the basis of n-type and p-type. Whenever the sun light falls on the module, it creates ‘Photovoltaic Effect’ which converts them into electricity. After that, the produced electricity needs to get stored in battery. Therefore, solar energy is the perfect renewable energy source as it does not need fossil fuel or any other fuel to burn, it uses the day light, no carbon emission and no noise production. For running a BTS, solar energy is the most efficient source.

The output of the panel depends on the efficiency of the module which has been developed over the years. In 1839, [14] when Aleixandre Edmond Becquerel discovered such material which could convert the light into electricity. Mainly, in 1840 William Grylls Adams built the world’s first photovoltaic power source whose efficiency was 1-2%. Nowadays, the solar panel we use was basically developed in early 1950s. D.M. Chapin, C.S. Fuller, and G.L. Pearson of Bell Laboratory invented it in 1954 where they used silicon, having efficiency of 4%. In the early 1990s, the cell got emerging improvement in efficiency which is almost 30% but it was not suitable for wide use. Later on, in 2000, Sandia Laboratories built the DC to AC inverter, which converted the DC current into AC current which is usable for household and others. In the recent 10 years, the developing has been remarkable in the commercial side. Commercial solar panels now have efficiency up to 29% whereas in lab test, it has touched 46%.



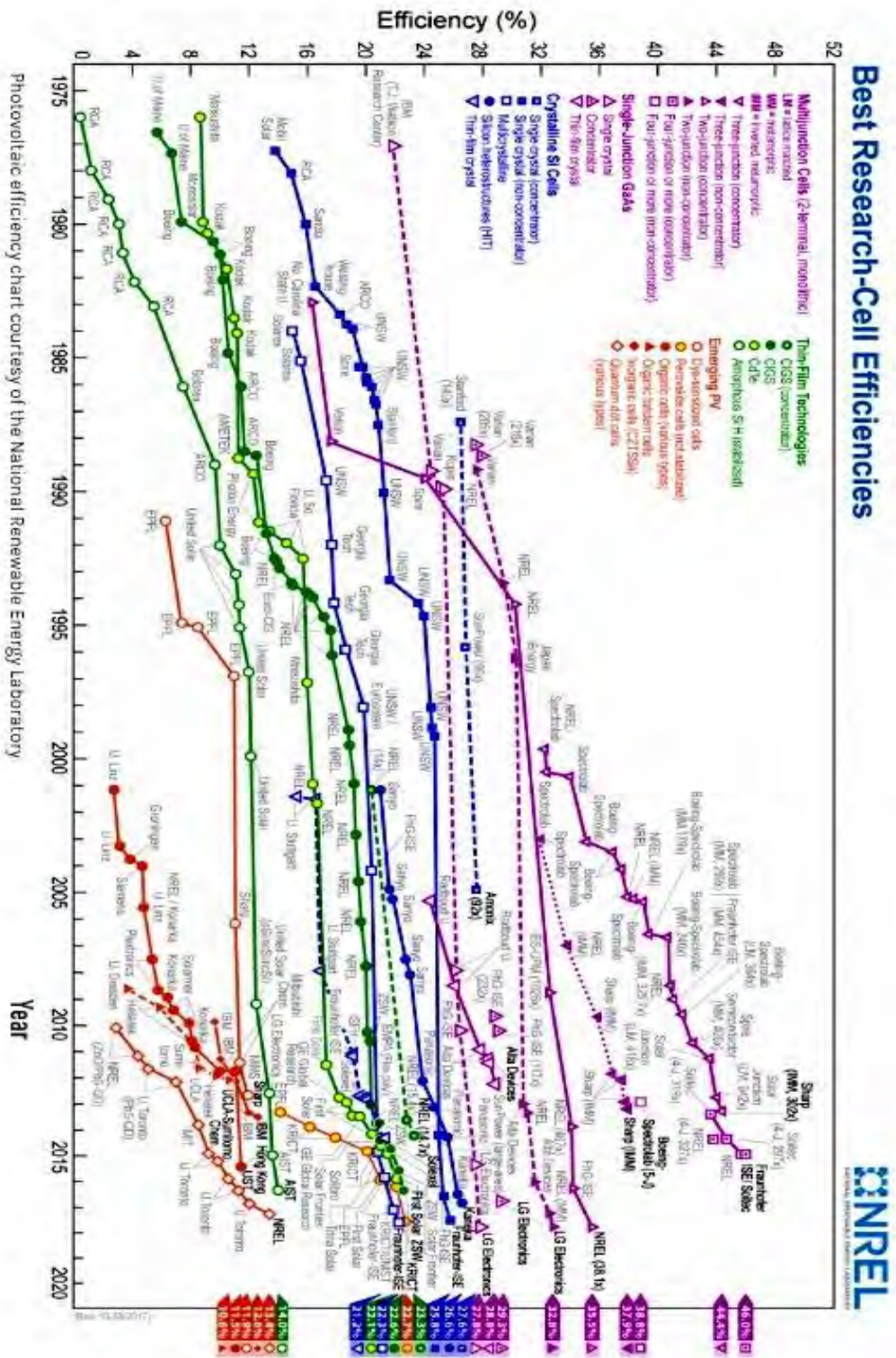

Fig 2.5: Cell efficiency development in research [13].

According to [13], the efficiency developing graph shows the scenario is rising which definitely reflects bright future of solar panel.

Along with the efficiency gets higher, the price of solar panel gets lower. Most importantly the decline rate is remarkable. Based on [15], it shows that the solar PV price was 7.5\$ per watt in 2009 which became 1.6\$ per watt in 2017. The installment cost reduced 70% since 2010. This fabulous decline rate in international market is making the solar panel more and more efficient for the commercial uses.

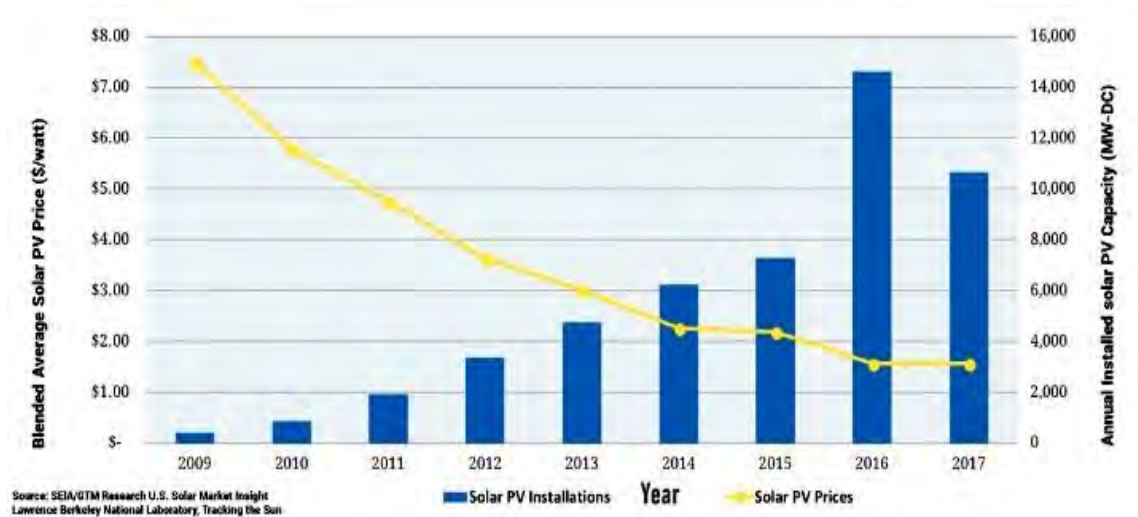

Fig 2.6: Decline rate of price for solar PV (\$/watt) and annual installed solar PV capacity (MW-DC) [15].

Besides, with the development of semiconductor materials the efficiency can be achieved much more than this. With the current materials theoretically the efficiency can be achieved up to 50%. In that sense, after 10 years the manufacturing cost may be below \$1 per watt.

According to [16], the size (sq. feet) depends on the output of the panel for the home and commercial use. Although it can vary based on efficiency. As a result, for higher efficiency it needs more panels for the same KW system which depends on the user requirement.

System Size	Economy Panels (Square FT)	Standard Panels (Square FT)	Premium Panels (Square FT)
5 KW	306	254	224
10 KW	612	508	448
15 KW	918	763	672

Table 2.1: Panel area based on KW system [16].

Above data analysis clearly shows why world should move forward to solar energy sources in present and near future.

## 2.5 Fuel cell (Recent and future)

In the current situation, the rising price of crude oil in the worldwide is pretty clear. So after 10 years, the price of oil will be so high and also the use of them. In that case, we must move towards to renewable energy for the BTS. In that case, we cannot merely depend on the solar cells for it. Cause the efficiency of the cells are still much low. Merely depending on the solar panels will not be a solution. Other sources can be gas, wind turbine, fuel cell or others. We can consider 'Fuel Cell' as one of the alternatives.



A fuel cell is a device which takes stored chemical energy and converts it to electrical energy directly. Essentially it takes the chemical energy that is stored within whatever energy source you have such as hydrogen, gasoline or methane and then through two electrochemical reactions it converts it directly to electricity. Since the conversion of the fuel to energy takes place via an electrochemical process and not combustion, the process is nonpolluting and efficient (three times more efficient than fuel burning). Fuel cells are theoretically much more efficient than conventional power generation. Example of energy conversions for a coal fired power station: Where chemical energy in coal is converted to heat. Heat (in the form of steam driving a turbine) is converted into mechanical energy. Then the mechanical energy is converted to electrical energy. Each conversion has its own inefficiencies, so the overall process is very inefficient. A fuel cell converts chemical energy directly into electrical energy and is, in theory, much more efficient.

There are different forms of fuel cell [18]. Such as:

- Polymer electrolyte membrane fuel cells.
- Direct methanol fuel cells.
- Alkaline fuel cells.
- Phosphoric acid fuel cells.
- Molten carbonate fuel cells.
- Solid oxide fuel cells.

Among them mostly used fuel cell is polymer electrolyte membrane fuel cells. Advantage of this cell is it requires only hydrogen; it can take oxygen from air and water to run. They are basically fueled with hydrogen which is added by reformers or fuel tanks. It operates relatively in lower temperature than other fuel cells, around 80° C [18].

As this is the new technology as energy source, lots of research works are still on process to make it affordable for all over the world. Still, the price graphs show that the rate of price is decreasing in an alarming rate. The stack price [19] of different forms of PEM fuel cells are declining over the years.

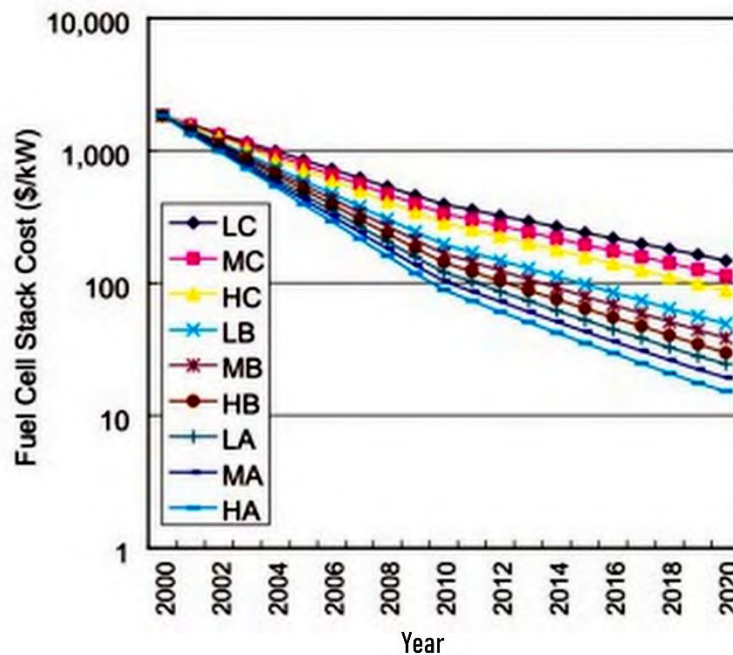

Fig 2.7: PEM stack price declining [19].

A study of U.S Department of Energy [20] shows that the projected system cost of PEM fuel cell in KWnet is decreasing in terms of manufacturing.

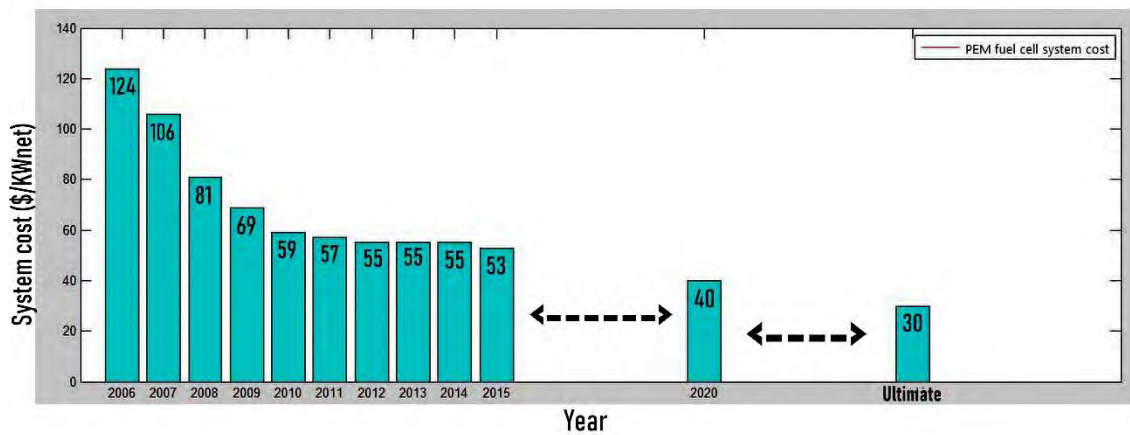

Fig 2.8: PEM fuel cell system cost declining in terms of manufacturing [20].

Different fuel cell and energy solution companies are using proton membrane as the fuel for their fuel cell generator which is already being used in different countries for the BTS sources. This generator is much more efficient, reliable with low maintenance cost along with no vibration and ensures green environment with zero carbon emission. Although, initial installment cost is high but yearly maintenance cost is low. Moreover, this is still ongoing research project; more developments will reduce the price of stack and generator in near future.

## CHAPTER 3

### POPOSED MODEL AND DESIGNING

#### 3.1 Proposed Model

A model has been proposed here for future solution which can be competitive with time. As the rate of fossil fuel is decreasing day by day, in near future all the power sources have to rely on the renewable energy sources or other alternative sources. In the circumstance, this model can be handy to provide full time power supply to the BTS. In the proposed model, we have made a combination of solar power source and fuel cell source with the final back up of diesel generator. Three alternative sources connected in parallel along with main grid which will be controlled by a controller system to activate one power system at a time to provide the necessary power to the system. First priority is set to grid line. When the grid fails to supply, the controller will automatically shift the input connection to other alternative energy sources one by one. After the controller decides the source, DC bus will supply the voltage to BTS and another connection will go to the air conditioner and other loads through buck converter and inverter. Design and flowchart is discussed in next subchapter.

### 3.2 Design

The design, provided in this chapter (Fig: 3.2) is the proposed model where all the sources are connected in a system to run the BTS. Here, the main source is coming from the grid line which provides 220 V AC supply. AC current comes from the grid and gets converted into 48 V DC supply by the rectifier. Then the connection goes to the controller system which sends the DC current to the DC bus. DC bus provides same voltage to the BTS and second connection goes to the buck converter. Here buck converter is being used to convert the 48 V DC to 12 V DC.

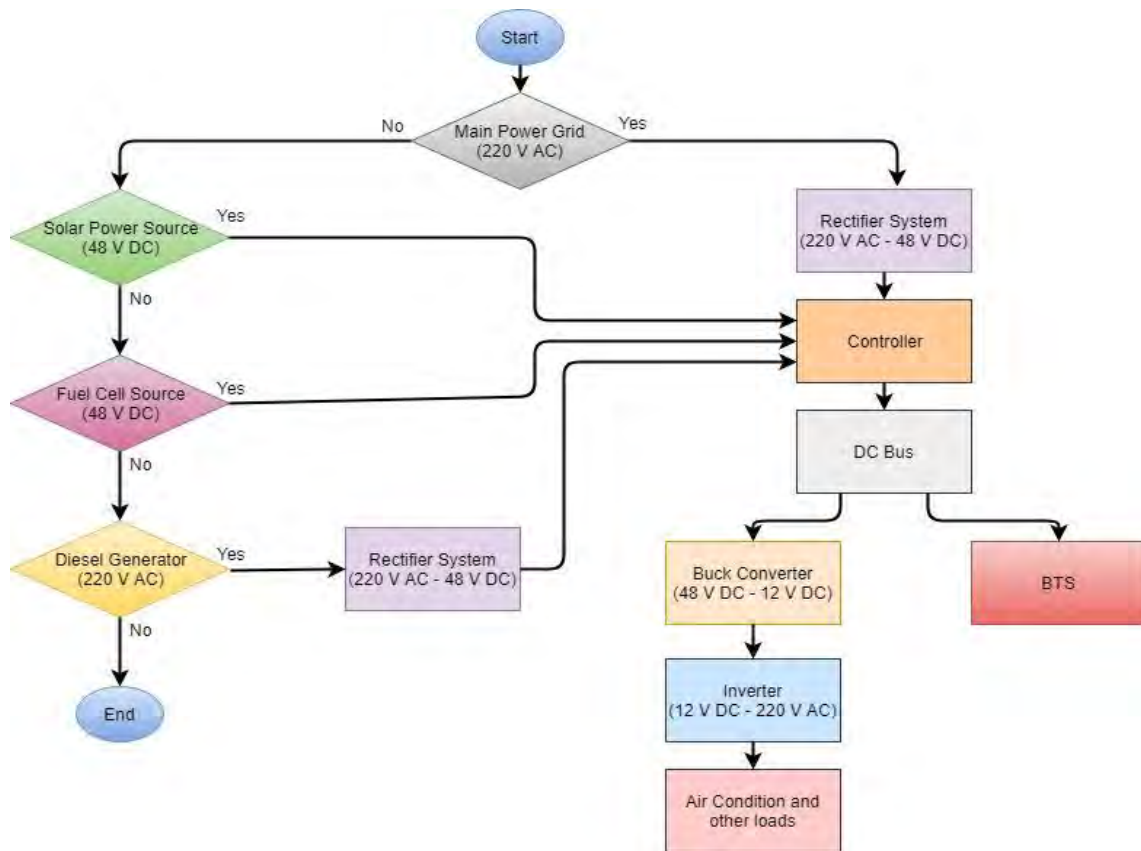

Fig 3.1: Flowchart of the proposed model.

Along with that, inverter is used in between buck converter and the air conditioner and loads as the inverter converts the DC source into 220 V AC source. If the main grid fails, controller senses it and switches the connection to the solar system. Here we are using 8 KW solar panel which is providing 48 V DC supply. Therefore, no need to use rectifier in between the solar panel and the controller. Controller sends the voltage directly to the DC bus. In addition to that, if the solar panel fails to supply or being disconnected for maintenance purpose, controller senses it and switches the connection to the fuel cell source.

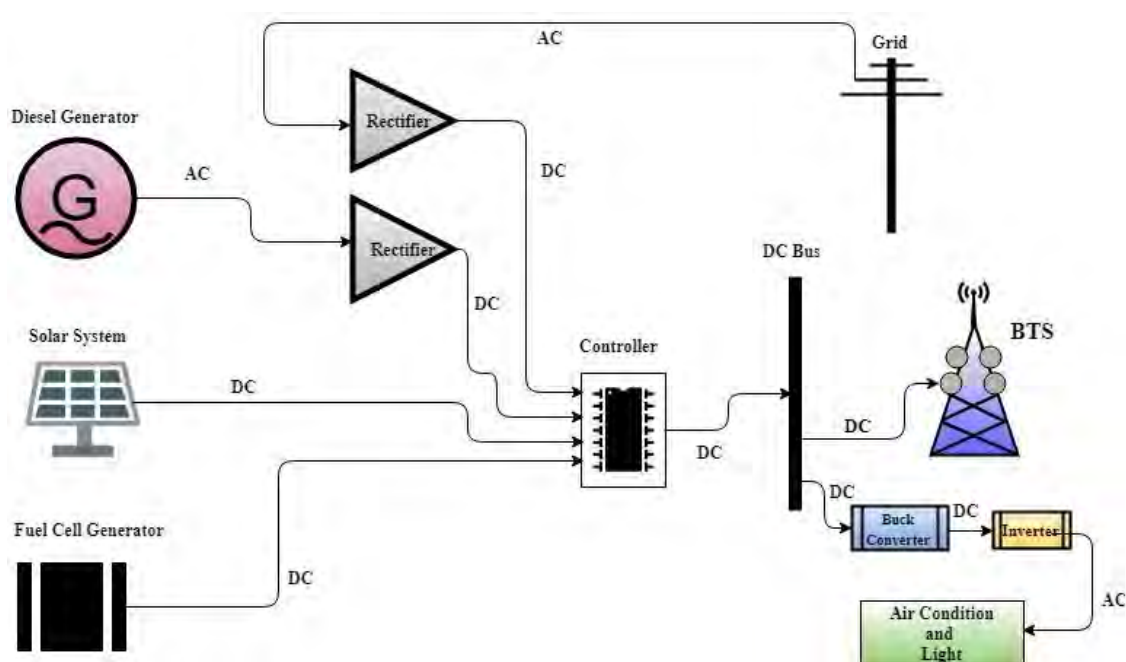

Fig 3.2: Proposed design of the system.

In this model, we are suggesting 8 KW fuel cell generator which provides 48 V DC supply to the line. As working as the solar cell, it does not require any rectifier in between the controller and

the source. Finally, diesel generator is added for last back up. When all the sources fail, mentioned above, then the diesel generator starts to run which can required for very short period of time or when the load shedding period increases more than two hours. In this connection, rectifier is added again as the diesel generator produces 220 V AC current which needs to get converter into 48 V DC. Again the controller sends the current to the DC bus. This is how, the model will work. This system shows the sources are connected in parallel so that more sources can be attached or the user can use fewer sources as well.

### **3.3 Advantages of the proposed model**

Main purpose of the model is to make sure less dependency on the fossil fuel. We are using solar system and fuel cell generator as the alternative energy sources for the BTS. As the sources are connected in parallel so there are more rooms available for other sources or swapping any source with another source based on the condition of the country or user demand. Along with that, it is helpful for doing any maintenance of any source without hampering the electricity supply to the BTS. Although we are considering for two hours load shedding period in the circumstances of Bangladesh, this model is capable to supply electricity based on the demand just by upgrading or swapping the sources. Another important purpose is to make sure green energy which is a burning question in the modern era. As the model uses renewable energy sources, it produces zero carbon di oxide and no carbon emission is happening here, this model definitely will put important impact on the environment. How the model can reduce carbon emission is discussed on the chapter 5. Along with that, the output cost analysis yearly and over the next fifteen years, are showed and calculated in the chapter 4.

## CHAPTER 4

### MATHEMATICAL MODEL

In this chapter, we have calculated the yearly output cost of per year if a system is installed in the running year and also calculated the yearly cost of next 15 years. Thus we compared the outcome of different sources individually. Later on, we compared the diesel generator cost with solar and fuel cell source to show which one is more efficient. Therefore, we calculated our proposed model system cost by predicting the run time of in different season of the year. Along with that, we compared the proposed model system cost with the diesel generator to see the cost difference. Moreover, we also showed the difference between diesel generator costs and if our proposed model is run by only solar system as solar is the most efficient source of energy. Finally, we assumed the future fuel cell system cost to compare with the diesel generator cost to clarify our aim of the research. From above calculations, we can show the differences between all three sources and their future outcome cost. We have made the comparisons more visible to the user to let them decide what source to choose and why. All details calculations and data analysis with formula are discussed in the following sub chapters, where the user can change their input data according to need to get the ultimate output.



## 4.1 Diesel generator output

Diesel generators are the traditional generators which all the operators use for their off grid period. Here we calculated whole data of installation cost along with diesel cost (Considering the rate of increase per year) and also based on the lifetime of the generator. Therefore, depreciation cost is also considered within the value.

Yearly total cost of diesel generator,  $T_g = \{P_g - (D_g * A)\} + \{(D_{pl} * T) * 365\}$

$P_g$  = Generator price in BDT

$L_d$  = Lifetime of generator

Yearly depreciation of generator,  $D_g = P_g / L_d$

$A$  = Age of generator in years

$T$  = Running time per day

$D_{pl}$  = Diesel price per liter in BDT

Here we considered the diesel generator price = 1500000/- BDT (As the value varies for different providers or company, this is the average price of 10 KW diesel generator in 2018)

Lifetime of generator,  $L_d = 20$  years (Considering average lifetime of the generator)

Diesel price per liter in 2018 = 65/- BDT [11]

Diesel price increasing rate = 1.81% per year [11] [12]

Running time per day in hour,  $T= 2$  hours (Considering the average load shedding time of Bangladesh per day)

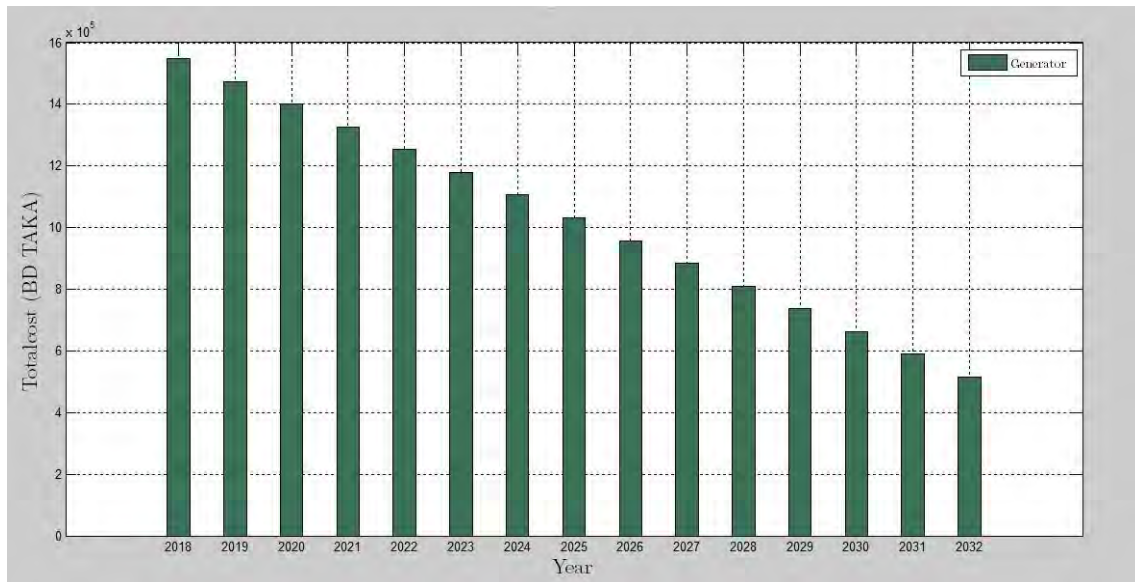

Fig 4.1: Diesel generator system cost over the years (2018 – 2032)

In the above graph, it is showed that if the system is installed in 2018, initially at the first year total system cost is,

$$T_g = \{P_g - (D_g * A)\} + \{(D_{pl} * T) * 365\} \dots\dots\dots (i)$$

$$= \{1500000 - (0 * 0)\} + \{(65 * 2) * 365\}$$

$$= 1547450/-$$

This is the first year total cost. From the next year, depreciation cost of diesel generator will be subtracted from the generator price of previous year, which we calculated as,

$$D_g = P_g / L_d = 1500000 / 20 = 75000 \text{ /-}$$

Same way, we calculated the total cost of next 15 years.

This way the system will require total cost in 2032,

$$\begin{aligned} T_g &= \{P_g - (D_g * A)\} + \{(D_{pl} * T) * 365\} \\ &= \{1500000 - (75000 * 14)\} + \{(90.34 * 2) * 365\} \\ &= 515948 \text{ /-} \end{aligned}$$

Where the diesel price,  $D_{pl} = 90.34 \text{ /-}$  (With the increase rate of 1.81% per year)

The user can give any input in the formula (i) to get the desired output of any year.

## 4.2 Solar panel output

Our main back up source of the proposed model is solar system. Here we calculated the full installation cost along with batteries and inverter (Considering the depreciation of both panel and batteries) and also the lifetime of both panel and batteries individually to get the total output. We are suggesting a 8 KW peak battery backup solar system whose operating load is 6.5 KW and gives output voltage 48 V DC and can give back up of 2 hours in full load condition.

$$\text{Yearly total cost solar panel system, } T_s = [\{P_p - (D_p * A_s)\} + n * \{B_p - (D_b * A_b)\}] \dots \dots \text{ (ii)}$$

$P_p$  = Panel price (Including inverter)

$L_p$  = Panel lifetime

Yearly depreciation of panel,  $D_p = P_p / L_p$

$A_s$  = Age of the panel in years

$B_p$  = Battery price

$L_b$  = Battery lifetime

Yearly depreciation of battery,  $D_b = B_p / L_b$

$A_b$  = Age of the battery in years

$n$  = Number of batteries

Here we considered the panel price,  $P_b = 897000/-$  (Varies from company to company)

Panel lifetime,  $L_p = 20$  years

Battery price,  $B_p = 13074/-$

Number of batteries,  $n = 27$

Battery lifetime,  $L_b = 5$  years

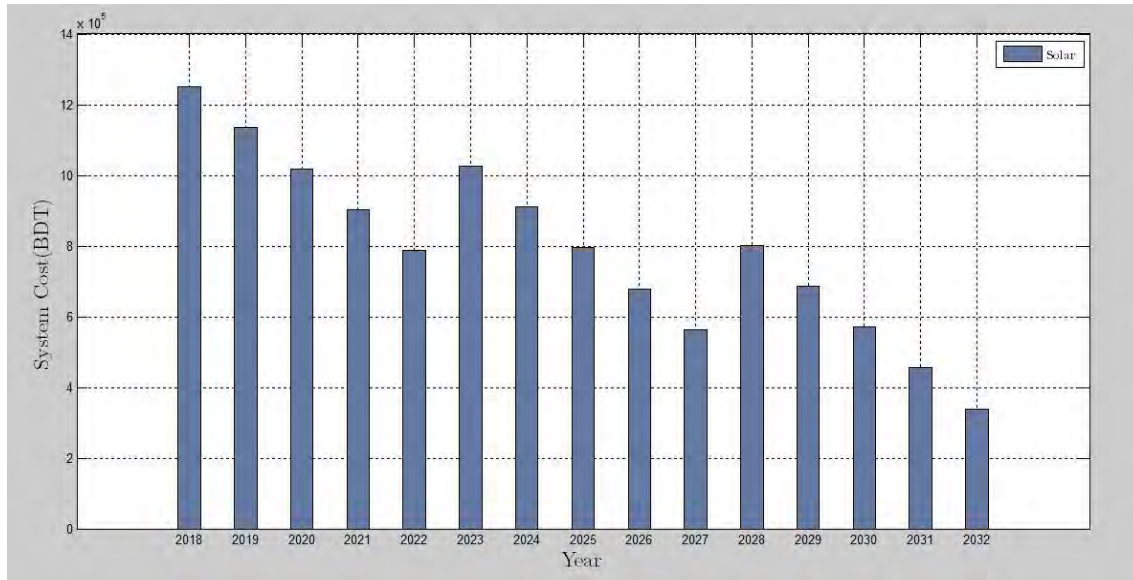

Fig 4.2: Solar panel system cost over the years (2018 – 2032).

In the above graph, it is showed that if the system is installed in 2018, initially at the first year total system cost is,

$$\begin{aligned}
 T_s &= \{P_p - (D_p * A_s)\} + n * \{B_p - (D_b * A_b)\} \\
 &= \{897000 - (0 * 0)\} + 27 * \{13074 - (0*0)\} \\
 &= 1250000/-
 \end{aligned}$$

This is the first year total cost. From the next year, depreciation cost of solar panel will be subtracted from the panel price of previous year, and also the depreciation cost of battery will be subtracted from the battery price of previous year, which we calculated as,

Yearly depreciation cost of panel,  $D_p = P_p / L_p = 897000 / 20 = 44850/-$

Yearly depreciation of battery,  $D_b = B_p / L_b = 13074 / 5 = 2614/-$

Same way we calculated the total cost of next 15 years. Batteries will be changed after every 5 years.

This way the system will require total cost in 2032,

$$\begin{aligned}
 T_s &= \{P_p - (D_p * A_s)\} + n * \{B_p - (D_b * A_b)\} \\
 &= \{897000 - (44850 * 14)\} + 27 * \{13074 - (2614 * 4)\} \\
 &= 339700/-
 \end{aligned}$$

The user can give any input in the formula (ii) to get the desired output of any year.

### 4.3 Fuel cell output:

Our secondary backup energy source is fuel cell source, which seems to be expensive in terms of primary installation cost along with the stack price. Still we showed the details cost analysis of the system. As this is going to be the most prolific source of energy in near future, we calculated and disclosed the recent installation with maintenance cost of now and next 15 years like we did for diesel generator and solar panel. In the proposed model, we suggested 8 KW fuel cell generator which requires hydrogen fuel stack to recharge and gives output of 48 V DC.

$$\text{Yearly total cost solar panel system, } T_r = \{P_{fg} - (D_{fg} * A_{fg})\} + n_s * \{S - (D_s * A_s)\} \dots \dots \text{(iii)}$$

$P_{fg}$  = Fuel cell generator price

$L_{fg}$  = Fuel cell generator lifetime

Yearly depreciation of fuel cell generator,  $D_{fg} = P_{fg} / L_{fg}$

$A_{fg}$  = Age of the fuel cell generator in years

$S$  = Stack price

$S_l$  = Stack lifetime

Yearly depreciation of stack,  $D_s = S / S_l$

$A_s$  = Age of the stack in years

$n_s$  = Number of stacks

Here we considered the fuel cell generator price,  $P_{fg} = 9786880/-$

Fuel cell generator lifetime,  $L_{fg} = 20$  years

Stack price,  $S = 364140/-$  (Horizon 1000 W PEM cell) [17]

Number of stack,  $n_s = 27$

Stack lifetime,  $S_l = 10$  years

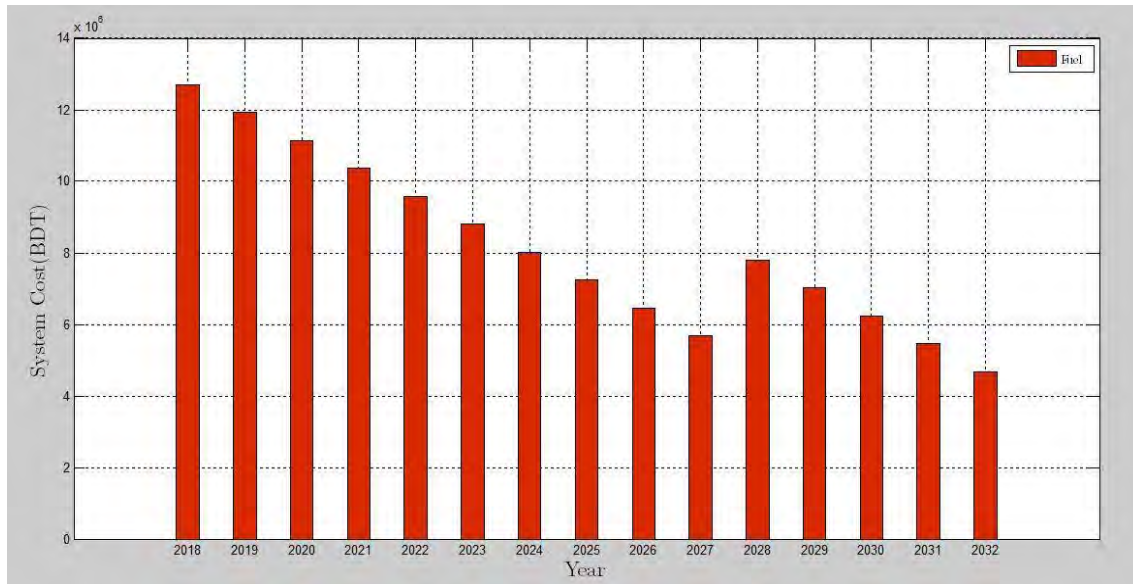

Fig 4.3: Fuel cell generator full cost over the years (2018 – 2032).

In the above graph, it is showed that if the system is installed in 2018, initially at the first year total system cost is,

$$\begin{aligned}
 T_f &= \{P_{fg} - (D_{fg} * A_{fg})\} + n_s * \{S - (D_s * A_s)\} \\
 &= \{9786880 - (0*0)\} + 8 * \{364140 - (0*0)\} \\
 &= 12700000/-
 \end{aligned}$$

This is the first year total cost. From the next year, depreciation cost of fuel cell generator will be subtracted from the generator price of previous year, and also the depreciation cost of stack will be subtracted from the stack price of previous year, which we calculated as,

Yearly depreciation of fuel cell generator,  $D_{fg} = P_{fg} / L_{fg} = 9786880 / 20 = 489344/-$

Yearly depreciation of stack,  $D_s = S / S_i = 364140 / 10 = 36414/-$



Same way we calculated the total cost of next 15 years. Stacks will be changed after every 10 years.

This way the system will require total cost in 2032,

$$\begin{aligned} T_f &= \{P_{fg} - (D_{fg} * A_{fg})\} + n_s * \{S - (D_s * A_s)\} \\ &= \{9786880 - (489344 * 14)\} + 8 * \{364140 - (36414 * 4)\} \\ &= 4683936/- \end{aligned}$$

The user can give any input in the formula (iii) to get the desired output of any year.

#### **4.4 Comparison and proposed model output**

In this sub chapter, first we compared the year based total price between diesel generator system along with the price of solar cell and fuel cell generator price which we got in the sub chapters of 4.1, 4.2 and 4.3.

Besides, we calculated the period wise yearly cost of our proposed model as in every season of the year, we do not need to run all the backups. We emphasized on the solar cell primarily as it is the cheapest convenient back up source. Along with that, when the solar panel will fail, we would move on the next source. Likewise we calculated for different period of time of the year.

Later on we showed the calculation of diesel generator VS yearly cost of our proposed model, same way if it is installed in 2018 and estimated till 2032.

Moreover, we showed the comparison between only solar panel and diesel generator cost.

And finally, we showed an assumed calculation of future fuel cell price and if so happened how it will affect the proposed model VS diesel generator graph.

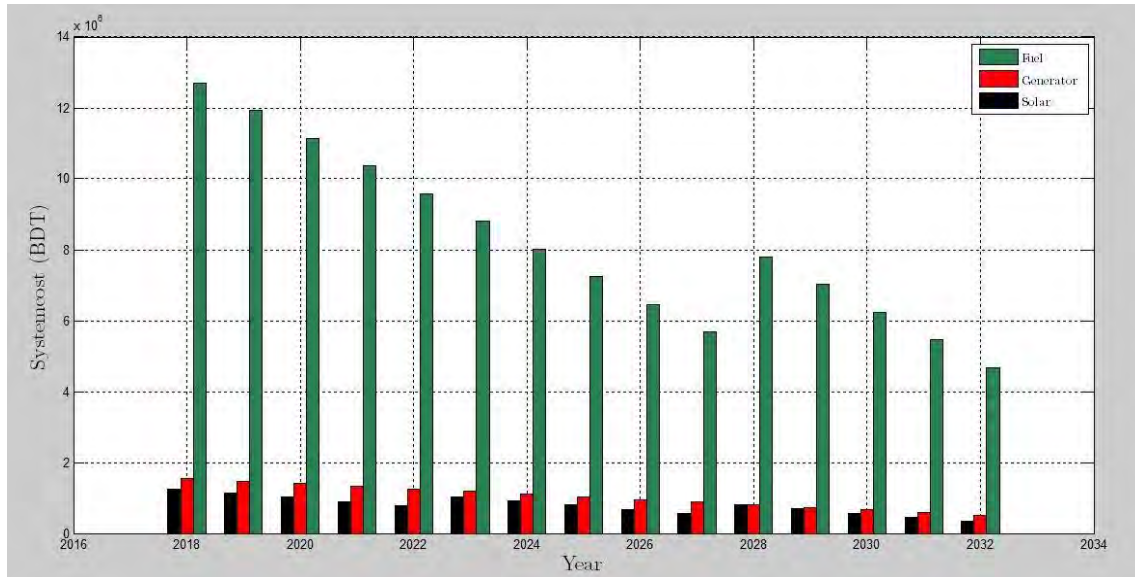

Fig 4.4: Comparison between diesel generator, solar panel and fuel cell energy (2018 – 2032)

From the above graph, we can see the clear comparison between the three sources of energy. As we can see the first year cost is highest among the individuals as installation cost is included here. Overall, fuel cell energy got the highest pick with the maximum cost and solar energy is the cheapest form of back up energy among these three.

After that we calculated the period wise cost of our proposed model. We divided the year in four different periods to run our proposed system. They are,

- 1) January – March, 2) April – June, 3) July – September and 4) October to December

For the number 1 period of the year, the weather forecast in Bangladesh is mostly summer season, so the solar cell can provide full time back up (2 hours) to the BTS during the off grid

time. But the scenario is not the same for the number 2 period of the year. There are mostly rainy season in this period of time in Bangladesh, so the solar cannot get enough light to charge themselves, for this reason we considered the solar panel can meet 50% of the demand and rest 50% time will be run by fuel cell. Following the order, during the number 3 period of the year, rainy season gets nearly done, so solar panel can get better time to recharge to give full time backup. We assumed this to be 75% and rest 25% will be given by fuel cell. And finally in the last period of the year, the solar will be able to get full time recharged to provide full service. Although this portion is during winter season, still the solar panel can get enough light to get recharged for giving full back up.

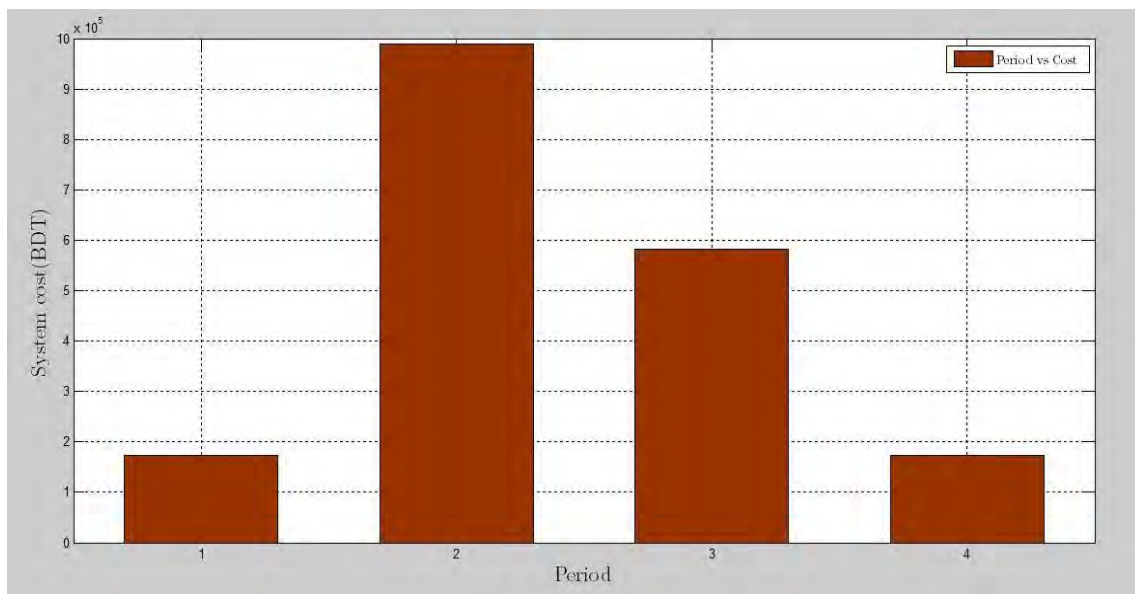

Fig 4.5: Period VS system cost yearly (On average of 15 years)

$$\text{Per period cost, } C = (T_{sh} * t) + (T_{fn} * t) + (T_{gh} * t)$$

$$\text{Solar cell cost per hour, } T_{sh} = \left[ \frac{(T_s/12)/30}{24} \right]$$

Fuel cell cost per hour,  $T_m = \left[ \frac{(T_f/12) \cdot 30}{24} \right]$

Diesel generator cost per hour,  $T_{gh} = \left[ \frac{(T_g/12) \cdot 30}{24} \right]$

Running time in hours =  $t$

Total cost of the year,  $C_m = C_1 + C_2 + C_3 + C_4$

$C_1$  = First period cost

$C_2$  = Second period cost

$C_3$  = Third period cost

$C_4$  = Fourth period cost

In the fig 4.5, we showed the average of 15 years for each period cost. And it clearly shows that the cost in the second period of the year is higher than rest others as fuel cell back up is being used 50% of the time here, rest 50% will be provided by solar cell. And also in the third period, cost is little higher, reason is the same as fuel cell is being used 25% of the time and rest 75% is provided by solar cell. But the first and fourth period is the cheapest part as solar cell is going to give backup for full time here.

Now, the comparison we showed for the total cost of the year of our system,  $C_m$  VS diesel generator cost. By the graph, we could find that in the most of the years, our proposed cost seems higher which has been for fuel cell. But the fact is, for the perspective of Bangladesh, solely fuel cell dependency is not possible. In that case, the price is adjusted by using solar cell most of the time. Moreover, this is based on the current pricing scenario of the fuel cell

which is much higher but in the near future it will keep decreasing but the diesel price will keep increasing.

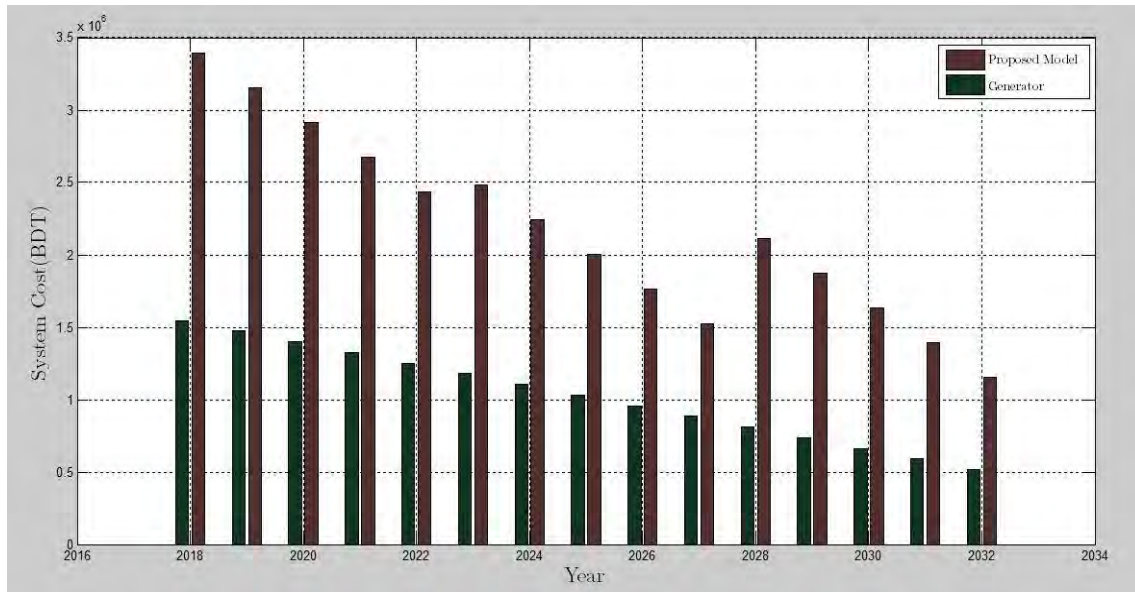

Fig 4.6: Cost per year for proposed model VS diesel generator cost per year (2018 – 2032).

To solve this, we showed another comparison of solar cell VS diesel generator. We assumed the system to run in solar cell over the year then the graph shows the result and solar cell cost is much lower than the diesel generator cost.

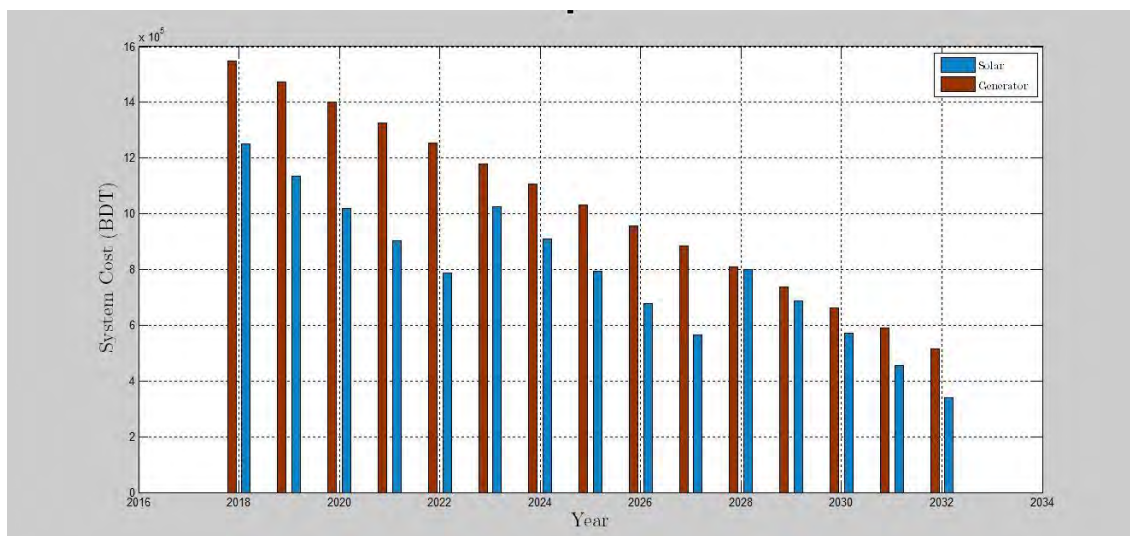

Fig 4.7: Solar cell cost VS generator cost (2018 – 2032).

And finally, as fuel is the most expensive source of energy among these three, our recent proposed model may also seem expensive. We assumed if after few years the fuel cell cost gets such lower that approximately the fuel cell generator cost become only twice of the diesel generator and the stack price gets more than 4 times lower than the recent time price, then how the scenario will look like.

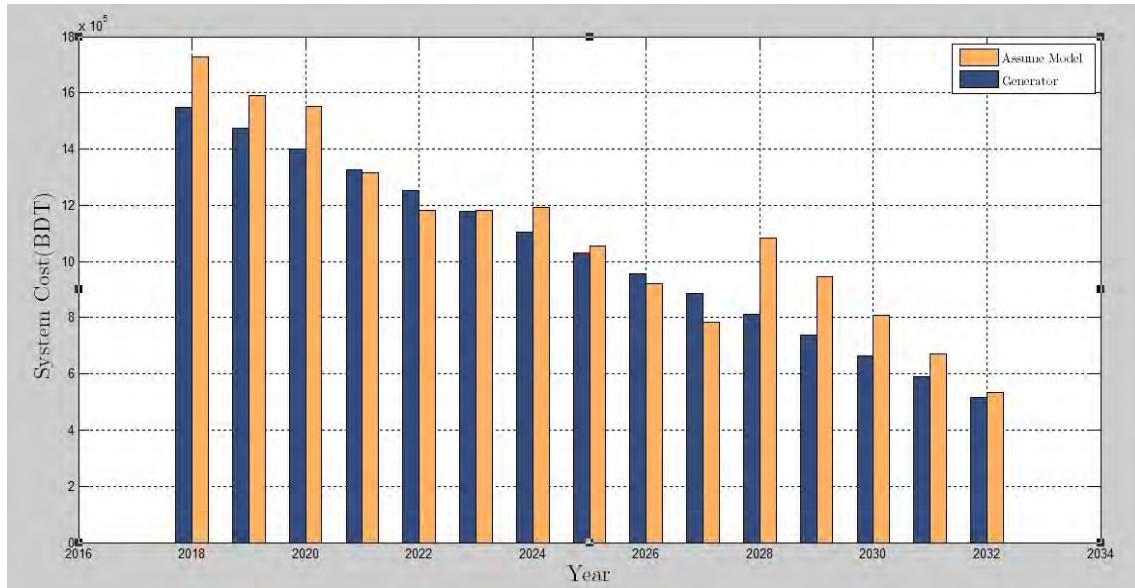

Fig 4.8: Proposed system cost VS diesel generator (2018 – 2032).

Here assumed fuel cell generator price,  $P_{fg} = 3000000/-$

Stack price,  $S = 800000/-$

Then calculated the total fuel cell cost,  $T_f$  for each year and then found out the value of our proposed model cost,  $C_m$ .

## CHAPTER 5

### GREEN ENERGY

#### 5.1 Emission of CO<sub>2</sub>

The burning of fossil fuels has increased at a significant amount over the last 50 years. Therefore, the emission of carbon dioxide and other greenhouse gases has increased heat in the lower atmosphere which is continuously warming the global climate. According to [21], the world has heated up approximately 0.85 degree Celsius since 1850. This heat change is causing extreme weather change such as sea level rising, glacier melting and precipitation pattern change. Also other weather events are becoming more frequent and catastrophic. This increase in heat is causing many extreme diseases to increase such as respiratory diseases because the increase in heat produces pollen and other aeroallergen which can trigger asthma affecting around 300 million people worldwide. As well as, this ongoing temperature rise is going to increase this problem in a more catastrophic disaster. Based on [22], due to higher energy demand the increase in carbon dioxide emission rose to approximately 37 billion metric ton in the year 2017 which is the highest ever.





Fig 5.1: Diesel generator, polluting environment [23].

## 5.2 Why green energy?

We have very limited resources on our earth so eventually every resource will extinct after a certain period of time. So the best step against this threat is to convert our need of energy to green energy sources. At present many developed countries are converting to green energy sources due to limited resources and nature consciousness. Besides, green energy has a lot of benefits on our nature. Carbon di oxide emission is overloading our atmosphere with global warming which is causing severe impact on the nature such as frequent storms, sea level rise, drought, extinction. The rise in heat worldwide has grown into a crucial position as the carbon di oxide emission has hit record break the last year.

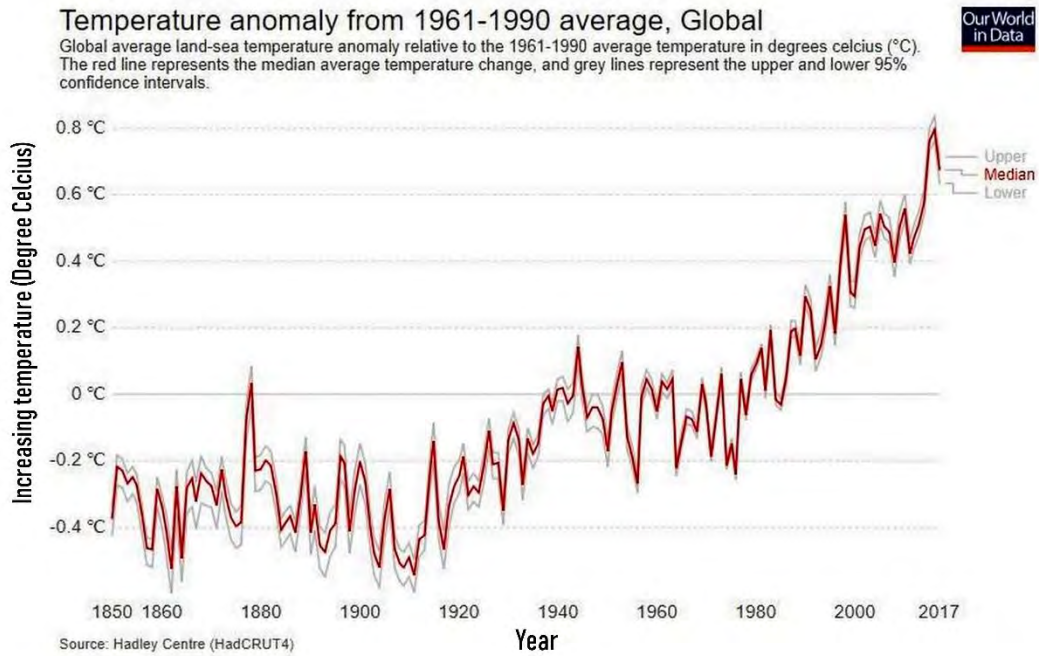

Fig 5.2: Temperature anomaly graph [24].

From the above graph, we can see that the temperature rising rate from 1850 to 2017 which looks dangerous in recent past.

### 5.3 CO<sub>2</sub> emission by diesel fuel

This is approximate fuel consumption for different KW/KVA diesel generator.

Generator size	1/4 load (Liter/Hour)	1/2 load (Liter/Hour)	3/4 load (Liter/Hour)	Full load (Liter/Hour)
8 KW / 10 KVA	0.9	1.2	1.7	2.1
10 KW / 12 KVA	1.0	1.4	2.1	2.6
12 KW / 15 KVA	1.3	1.8	2.6	3.2
16 KW / 20 KVA	1.7	2.4	3.5	4.3
20 KW / 25 KVA	2.1	3.0	4.3	5.4
24 KW / 30 KVA	2.6	3.6	5.2	6.4
32 KW / 40 KVA	3.4	4.8	7.0	8.6
40 KW / 50 KVA	4.3	6.0	8.6	10.7
60 KW / 75 KVA	6.4	9.0	12.7	16.1
80 KW / 100 KVA	8.3	11.9	16.1	21.4
120 KW / 150 KVA	10.9	17.3	24.1	32.1
160 KW / 200 KVA	14.1	22.9	32.7	42.8
200 KW / 250 KVA	17.4	28.6	40.8	53.5
280 KW / 350 KVA	23.7	39.3	56.0	74.9
400 KW / 500 KVA	33.3	55.6	79.6	107.0

Table 5.1: Approximate diesel fuel consumption [25].

From the table 5.1, we can see that for a 10kW/12kVA generator 2.6 liters of fuel is needed per hour to operate with full load. According to [26], each gallon of diesel fuel consists of 2,778 gm. of pure carbon and when carbon is oxidized each gm. of carbon produces 3.666 gm. of carbon di oxide. Usually in a diesel engine of liquid hydrocarbon burning engine 99 percent of fuel oxidizes and 1 percent emits as particulates.

1 gallon = 3.78541 liter

3.78541 liters contains 2778 gm. for carbon.

So, 2.6 liters of diesel fuel contains  $2778 * 2.6 / 3.78541 = 1908$  gm. of carbon

Therefore, a 10kW/12kVA generator produces  $1908 * 3.666 * 0.99 = 6925$  gm. of carbon di oxide each hour.

## **5.4 Comparison in terms of Bangladesh**

According to [27], the carbon di oxide emission per capita for the year 2016 was 0.46 metric tons in Bangladesh. This emission per capita of Bangladesh has increased from 0.18 metric tons in the year 1997 to 0.46 metric tons in 2016. And so the average growing rate annually is 5.17%. Here carbon dioxide emission occurs due to fossil fuel burning and manufacturing of cement and other industrial products.

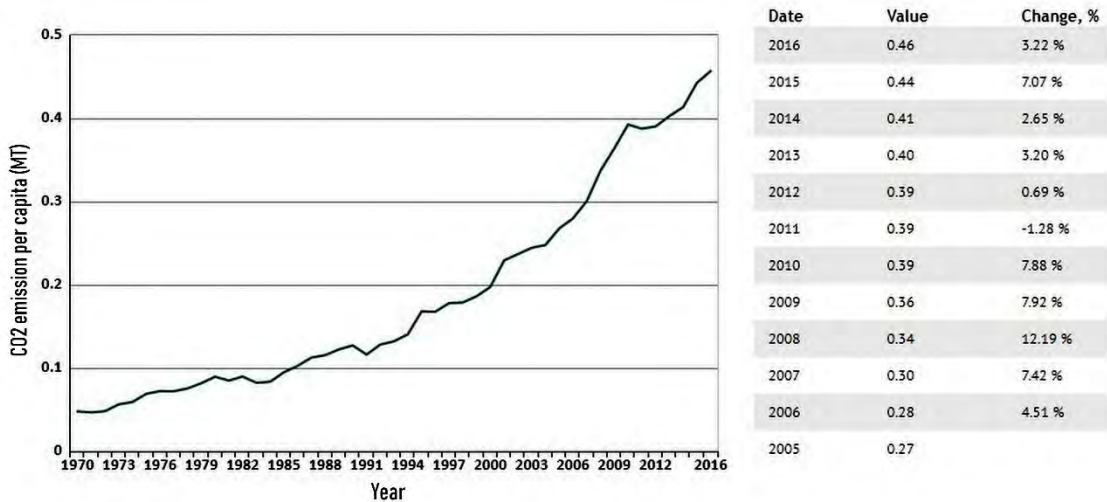

Fig 5.3: Bangladesh CO<sub>2</sub> emission per capita graph [27].

According to [28], in the year 1972 the total amount of carbon dioxide emission was 3509 kiloton which has increased up to almost 75000 kiloton in 2014. So the increasing rate is 1700 kiloton per year. So according to the increasing rate the emission will be almost 80000 kiloton. So in 2028 it will be minimum 97000 kiloton.

On the other hand Base Transceiver Station produces .018 metric ton of carbon dioxide per year due to fuel burning in generator during the load shedding which is for an average of 2 hours daily.

At present (2018), the total number of Base Transceiver Stations are 36487. The Increasing rate of Base Transceiver Station per year is approximately 2351. As per increasing rate the total number of Base transceiver Station will be approximately 60000 in the year 2018. So

the CO<sub>2</sub> emission in 2028 is almost 300 kiloton. If we use green energy for powering Base Transceiver Station then we can reduce 300 kiloton of carbon dioxide.

For Bangladesh,

**Y**= Current Year

**N**= Year Difference

**X**= Current Carbon dioxide emission condition

**Z**= Increasing rate per year

So,

$$Y + N = X + Z * N$$

$$2018 + 10 = 80000 + (1700 * 10)$$

$$\Rightarrow 2028 = 97000 \text{ kilo ton}$$

It shows that in 2028, CO<sub>2</sub> emission will be 97000 kilo ton in Bangladesh.

Now, for Base Transceiver Station,

**Y**= Current Year

**N**= Year difference

**X**= Current Carbon dioxide emission from Base Transceiver Station

**Z**= Base Transceiver Station Increasing rate per year

**C**= Carbon Dioxide emission per Base Transceiver Station

So,

$$Y + N = X + (Z * N * C)$$

$$\Rightarrow 2018 + 10 = 188495106 + (2351 * 10 * 4988)$$

$$\Rightarrow 2028 = 306 \text{ kilo ton (approx.)}$$

Here,

**X** = CO<sub>2</sub> emission per hour for generator per BTS \* Usage hour \* Days \* Number of BTS

$$= 6.925 \text{ kg} * 2 * 365 * 37287$$

$$= 188495106 \text{ kg}$$

Means the recent BTS can produce 306 kilo ton CO<sub>2</sub> in 10 years. Whereas if we use our proposed model, this amount of CO<sub>2</sub> emission can be prevented after 10 years.

## **CHAPTER 6**

### **CONCLUSION**

#### **6.1 Summary**

In the whole research, we analyzed the condition of recent and future of diesel generator, solar cell and fuel cell. Along with that, we proposed a model which can combine the three backup sources, mostly reliable on the solar cell and fuel cell. We discussed the basic mechanism of the proposed model along with that we calculated the individual data of diesel generator, solar panel and fuel cell source and also the combination in between them. Besides we also showed the comparison of diesel generator usage cost with the proposed model yearly outcome along with the outcome of next 15 years which must help the user or the provider to choose the best solution for them. And finally, we also added the CO<sub>2</sub> emission data of the world and emphasized on the scenario of Bangladesh. Added with that, we calculated the CO<sub>2</sub> emission data for BTS on each year and showed how our proposed model can be handy to reduce the CO<sub>2</sub> rate of the environment.

#### **6.2 Drawbacks and possible recovery of the proposed model**

Main drawback of the system is the cost difference. The fuel cell technology is a new invention and a developing one. So it is an expensive option at present. But in future the price might decrease as shown in figure [4.8]. In our proposed model we demonstrated the alternative power sources for BTS because in near future fossil fuel is going to be extinct. So



companies will need a different power source to power their BTS. We have shown comparisons with different combinations between fuel cell, solar and diesel so that the user can choose a preferable option.

### **6.3 Future works**

Future development and upgrade can be huge in this base design as there are lots of room to develop the whole system and also room for adding more sources. This is just a future visualization for the companies to look what happens and what may happen in the costing for different sources of energy. We calculated only for the BTS though, but the dependency on fossil fuel must be reduced from all sector to go for green energy in near future. We are not claiming that these data are the best and also not recommending particular one source, the user and the companies have freedom to choose their own based on their demand and future prospects.

In the conclusion, we can say that this paper is a reflection of cost analysis for the Base Transceiver Stations in Bangladesh which can be implemented at any other system based on the requirement. In the other cases, the design may vary for other.

## REFERENCES

- [1] "Mobile Phone Subscribers in Bangladesh June, 2018. | BTRC", *Btrc.gov.bd*, 2018. [Online]. Available: <http://www.btrc.gov.bd/content/mobile-phone-subscribers-bangladesh-june-2018>. [Accessed: 25- Jul- 2018].
- [2]"Grameenphone touches 10,000 3G BTS landmark | Grameenphone", *Grameenphone.com*, 2016. [Online]. Available: <https://www.grameenphone.com/about/media-center/press-release/grameenphone-touches-10000-3g-bts-landmark>. [Accessed: 25- Jul- 2018].
- [3]S. Report, "Banglalink to sell out its towers", *The Daily Star*, 2017. [Online]. Available: <https://www.thedailystar.net/business/telecom/banglalink-sell-out-its-towers-1357534>. [Accessed: 25- Jul- 2018].
- [4]"Axiata Group – One of Asia’s largest telecommunications groups", *Axiata.com*, 2018. [Online]. Available: <https://www.axiata.com/operating/company/22/>. [Accessed: 25- Jul- 2018].
- [5] S. Report, "Banglalink to sell out its towers", *The Daily Star*, 2018. [Online]. Available: <https://www.thedailystar.net/business/teletalk-not-ready-roll-out-4g-1536331>. [Accessed: 25- July- 2018].
- [6]J. Jose and V. Cherian, "A REVIEW ON DESIGN AND COST ANALYSIS ON HYBRID POWER SOLUTION FOR REMOTE TELECOM TOWERS", *Troindia.in*, 2015. [Online]. Available: <http://troindia.in/journal/ijcesr/vol2iss7/211-217.pdf>. [Accessed: 25- Jul- 2018].

- [7] A. Ayang, P. Ekam, B. Videme and J. Temga, "POWER CONSUMPTION: BASE STATIONS OF TELECOMMUNICATION IN SAHEL ZONE OF CAMEROON: TYPOLOGY BASED ON THE POWER CONSUMPTION—MODEL AND ENERGY SAVINGS", *Journal of Energy*, 2016. [Online]. Available: <https://www.hindawi.com/journals/jen/2016/3161060/>. [Accessed: 25- Jul- 2018].
- [8] Ecotricity.co.uk. (2018). *The end of fossil fuels*. [online] Available at: <https://www.ecotricity.co.uk/our-green-energy/energy-independence/the-end-of-fossil-fuels> [Accessed 25 Jul. 2018].
- [9] Bp.com. (2018). *BP Statistical Review of World Energy June 2016*. [online] Available at: <https://www.bp.com/content/dam/bp/pdf/energy-economics/statistical-review-2016/bp-statistical-review-of-world-energy-2016-full-report.pdf> [Accessed 25 Jul. 2018].
- [10] Planetforlife.com. (2004). *Current World Oil Situation*. [online] Available at: <http://planetforlife.com/oilcrisis/oilsituation.html> [Accessed 25 Jul. 2018].
- [11] GlobalPetrolPrices.com. (2018). *Bangladesh diesel prices*. [online] Available at: [https://www.globalpetrolprices.com/Bangladesh/diesel\\_prices/](https://www.globalpetrolprices.com/Bangladesh/diesel_prices/) [Accessed 25 Jul. 2018].
- [12] Knoema.com. (2016). *Bangladesh Diesel price, 1960-2017*. [online] Available at: <https://knoema.com/atlas/Bangladesh/Diesel-price> [Accessed 25 Jul. 2018].
- [13] Energy.gov. (2017). *Photovoltaics Research and Development | Department of Energy*. [online] Available at: <https://www.energy.gov/eere/solar/photovoltaics-research-and-development> [Accessed 25 Jul. 2018].

[14] Dilthey, M. (2018). *Solar Panel Efficiency Over Time* | *Solar Power Authority*. [online] Solar Power Authority. Available at: <https://www.solarpowerauthority.com/history-of-solar-power-technology> [Accessed 25 Jul. 2018].

[15] SEIA. (2018). *Solar Industry Research Data* | *SEIA*. [online] Available at: <https://www.seia.org/solar-industry-research-data> [Accessed 25 Jul. 2018].

[16] Tarbi, L. (2009). *How Many Solar Panels Do I Need For My Home in 2018?* | *EnergySage*. [online] Solar News. Available at: <https://news.energysage.com/how-many-solar-panels-do-i-need/> [Accessed 25 Jul. 2018].

[17] Fuelcellstore.com. (2018). 1kW to 5kW Fuel Cell Stacks. [online] Available at: <http://www.fuelcellstore.com/fuel-cell-stacks/high-power-fuel-cell-stacks> [Accessed 25 Jul. 2018].

[18] Energy.gov. (n.d.). *Types of Fuel Cells* | *Department of Energy*. [online] Available at: <https://www.energy.gov/eere/fuelcells/types-fuel-cells> [Accessed 25 Jul. 2018].

[19] A. Alaswad, A. Olabi and M. Dassisti, "PEM FUEL CELL COST ANALYSIS DURING THE PERIOD (1998 – 2014)", *Researchgate.com*, 2016. [Online].

[20] Hydrogen.energy.gov. (2016). *Hydrogen and Fuel Cell Activities, Progress and Plans*. [online] Available at: [https://www.hydrogen.energy.gov/pdfs/epact\\_fourth\\_report\\_sec811.pdf](https://www.hydrogen.energy.gov/pdfs/epact_fourth_report_sec811.pdf) [Accessed 25 Jul. 2018].

- [21] World Health Organization. (2018). *Climate change and health*. [online] Available at: <http://www.who.int/news-room/fact-sheets/detail/climate-change-and-health> [Accessed 25 Jul. 2018].
- [22] WELCH, C. (2017). *Carbon Emissions Had Leveled Off. Now They're Rising Again*. [online] News.nationalgeographic.com. Available at: <https://news.nationalgeographic.com/2017/11/climate-change-carbon-emissions-rising-environment> [Accessed 25 Jul. 2018].
- [23] Deccan Chronicle. (2018). *Diesel generators add to Bengaluru's toxic air*. [online] Available at: <https://www.deccanchronicle.com/nation/current-affairs/021117/diesel-generators-add-to-bengalurus-toxic-air.html> [Accessed 25 Jul. 2018].
- [24] Ritchie, H. and Roser, M. (2018). *CO<sub>2</sub> and other Greenhouse Gas Emissions*. [online] Our World in Data. Available at: <https://ourworldindata.org/co2-and-other-greenhouse-gas-emissions> [Accessed 25 Jul. 2018].
- [25] Ablesales.com.au. (2018). *Blog : Diesel Generator Fuel Consumption Chart in Litres*. [online] Available at: <https://www.ablesales.com.au/blog/diesel-generator-fuel-consumption-chart-in-litres.html> [Accessed 25 Jul. 2018].
- [26] Pedraza, J. (2016). *How to Calculate Carbon Dioxide Emissions from a Diesel Generator*. [online] researchgate.net. Available at: [https://www.researchgate.net/post/How\\_to\\_calculate\\_the\\_emission\\_from\\_diesel\\_generator\\_per\\_hour\\_Please\\_answer\\_with\\_supportive\\_documents](https://www.researchgate.net/post/How_to_calculate_the_emission_from_diesel_generator_per_hour_Please_answer_with_supportive_documents) [Accessed 25 Jul. 2018].

[27] Knoema.com. (2016). *Bangladesh CO2 emissions per capita, 1970-2017*. [online] Available at: <https://knoema.com/atlas/Bangladesh/CO2-emissions-per-capita> [Accessed 25 Jul. 2018].

[28] TheGlobalEconomy.com. (2018). *Bangladesh Carbon dioxide (CO2) emissions - data, chart* | *TheGlobalEconomy.com*. [online] Available at: [https://www.theglobaleconomy.com/Bangladesh/Carbon\\_dioxide\\_emissions](https://www.theglobaleconomy.com/Bangladesh/Carbon_dioxide_emissions) [Accessed 25 Jul. 2018].

# APPENDIX

## Rectifier

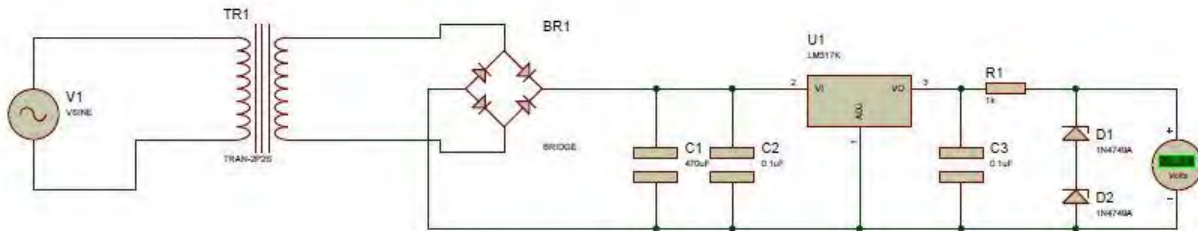

## Buck converter

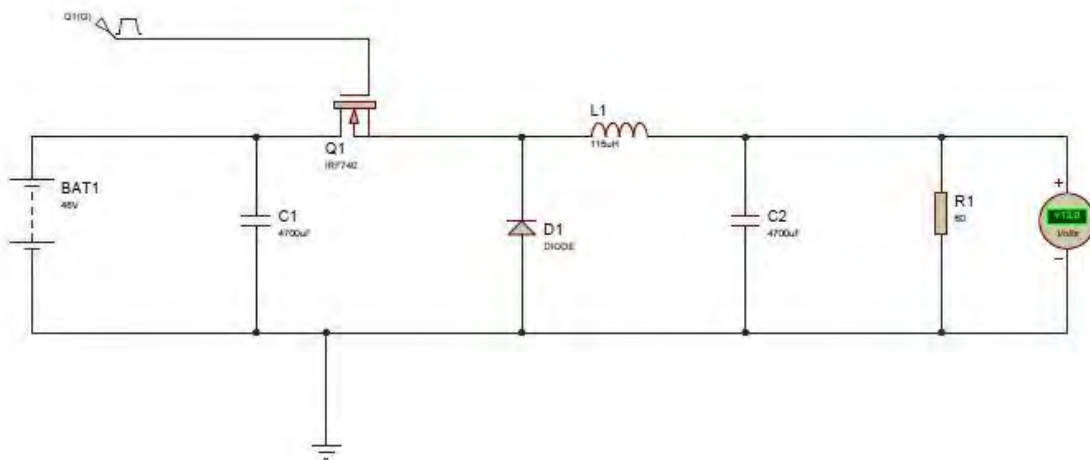

## Inverter

