

AUTOMATIC SHIP DOCKING SYSTEM

SUPERVISOR,

DR. MD. KHALILUR RAHMAN

Associate professor

PREPARED BY,

RABEYA AKTHER (11221062)

MD. SAFWAN BIN MOAZZEM (09221024)

BRAC
UNIVERSITY



BRAC UNIVERSITY



Thesis Report

Topic

Automatic Docking System using sonar

Prepared by :

Name	Id	Department	Signature
RabeyaAkther	11221062	EEE	
Md. Safwan Bin Moazzem	09221024	EEE	

Supervisor:

Name	Department	Signature
Dr. Md. Khalilur Rahman Associate professor	CSE	

Declaration

We hereby declare that this thesis paper is based on the results we found by our research and project work that is mentioned in details in this paper. This thesis project has not been previously submitted for any degree.

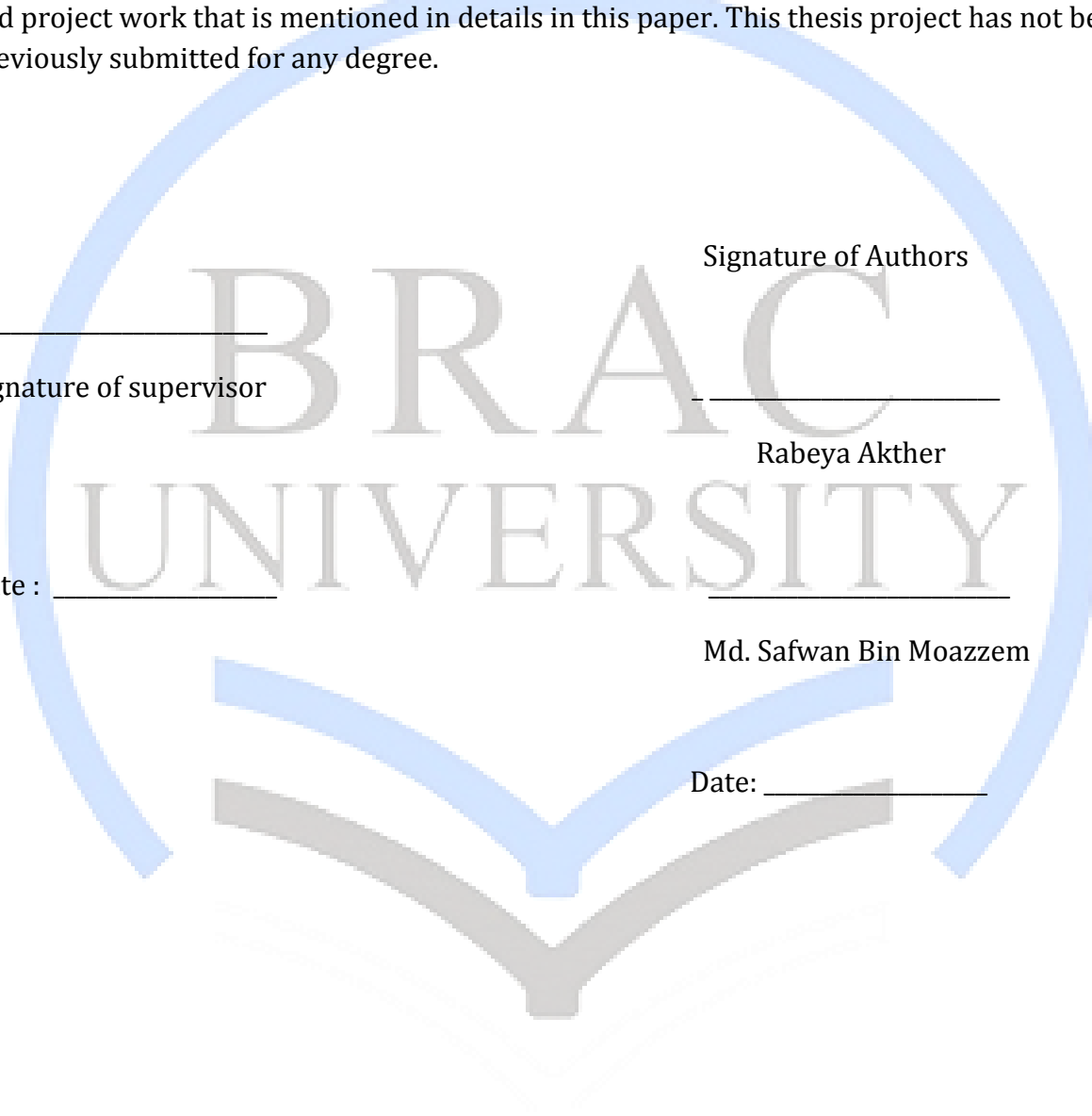

Signature of Authors _____

Signature of supervisor _____

Rabeya Akther

Date : _____

Md. Safwan Bin Moazzem

Date: _____

Acknowledgement

This thesis report has made possible through the help and support from the almighty, our parents, our supervisor, and finally our group members.

First and foremost we would like to thank our honorable supervisor Dr. Md. Khalilur Rahman for his most support and encouragement.

Secondly we like to thank all the members without whom our thesis project would remain incomplete and also for providing us with all the information that we needed. Especially, we would like to give our thanks to Mr. Monir Hossain and Mr. Jonayet Hossain for helping us to build up our project.

BRAC
UNIVERSITY



Abstract

Thesis on Automatic Docking

Since Bangladesh is crisscrossed by rivers, river ports and river ways have been playing a significant role to the transportation of goods here and there. Almost all big cities and commercial centers of Bangladesh have been established by the river-ports. In Bangladesh there are twenty two complete river-ports. Most of them are being used regularly.

Among of all the transport system mostly highest useable ones the roadways and secondly comes the water transport system. Because of the water transport system we all are aware of the water vehicles. Most of the water vehicles are being operated by the master driver along with junior master driver. To operate any kind of the water vehicle one of the masters required at least 7/8 years of the experience. Despite having masteries of the skill of driving sometimes they face problem regarding to the docking. It requires time and perfect observation to dock a vehicle. Therefore we have come up with the project of our thesis "Automatic Docking".

In this project we have used a small demo boat to examine the process of the docking. For detecting any kind of object we have used air sonar (HC-SR04), which basically used for detect any kind of object within the air range 2cm-400cm. since our boat is small we have used a small range of distance to docking our boat. It will start detecting dockyard when the boat will be in the range of 50cm. we have used two sonar to measure the distance. When the both of the sonar distance will be same it means that it's already in the close range of dockyard and done with docking the vehicle.

This project is based on the sonar's detecting system. It does not need the observation skill of the driver. Its more accurate then the skills of the master driver. A driver may not detect the vehicles at night, during rain, and foggy days but our sonar can detect the objects at those days too. So this simple circuit is easy to handle and it's cost effective.

We hope that through our project it will help the driver to avoid any kind of the accidents and risk of loss property also life. Many places like rural village do not have proper road transportation system during the rainy season. That time water vehicles are highly required in everywhere of Bangladesh. If we can ensure the safety of a passenger during their travel by water vehicles, then the water transportation system will become the safest transportation system of Bangladesh. Therefore, then anyone can travel or do business without having any kind of stress of losing property and life.

Table of contents:

Abstract

Chapter 1: Introduction

- 1.1- History of water transportation of Bangladesh
- 1.2- Length of the waterways.
- 1.3- Classifications of the water ports.
- 1.4- System of water transportations in Bangladesh
- 1.5- Lacking in water transportation in Bangladesh
- 1.6- Causes of waterways accidents.
- 1.7- How can government stop these accidents?
- 1.8- What is docking and what type of accidents happened because of docking.

Chapter 2: Objective

Chapter 3: Literature review

- 3.1- Where used the automatic docking recent days.
- 3.2- Project used for water transportation
- 3.3- What we learned from those systems.

Chapter 4: System Implementation

- 4.1- How will it work (picture and explanation)
- 4.2- Hardware part
 - 4.2a- First attempt with small PVC boat.
 - 4.2b- Final attempt with aluminum board and how boat is build.
- 4.3- Circuit part.
 - 4.3a- Sonar and its complications.

4.3b- How sonar gets connected with the LCD and Arduino.

4.3c- Total circuit picture with explanation.

4.4- Control software part

(Flow chart and Explanation)

Chapter 5: Testing

Chapter 6: Analysis and findings

Chapter 7: Limitations

Chapter 8: Discussion

Chapter 9: Conclusion

Chapter 10: Reference

Appendix



Chapter 1: Introduction

Bangladesh is a small country blessed with many rivers along with the Bay of Bangle. The Mother Nature also blessed us with the six different seasons because of that the beauty of Bangladesh known to everybody. Since Bangladesh is a river based country because of that water ways for transportation have been known from the old times. Because of the monsoon seasons most of the time rain fall around the whole country. As for that in many areas water transportation are being used as the number one transportation.

1.1 History of water transportation in Bangladesh

When how and where the system of transportation starts it is still unknown to the archeologist. However, the primary transportation system of Bangladesh is its extensive inland waterways. The history of transportation system in Bengal starts with water transport since the land is basically riverine and in the absence of a road system, waterways were preferred for movement and carrying goods from one place to another. People from all over the country came here with the help of water transportation, especially people from Asia, Arab countries, Turkeys, Portugal, France and England they all came for trading business by using the sea routes[1]. Since the Bangladesh is river based all of the business areas and cities were build on based on the surrounding rivers. That's why from a very long time ago the water transport system has been playing a significant role in our economy and life.

The British rulers had significant contribution in development of modern transportation system in the subcontinent and RAILWAY was first introduced in Bengal in 1862. The eastern part of Bengal, however, did not receive proper attention in this regard during the British period. The government of Pakistan also did not do much in developing the required transportation system in East Pakistan. After independence in 1971, Bangladesh inherited a transport network severely damaged during the WAR OF LIBERATION. The transport sector of Bangladesh experienced massive development with the help of donor

funding and technical assistance from abroad during the three decades after independence [1].

The number of launches and steamers registered with the Inland Water Transport Authority (IWTA) in 1970 was 2,712[1]. Some 18.9 million tons of cargo were moved by water transportation in 1986. As of early 1988, the country had 8,430 kilometers of navigable waterways, of which up to 3,058 were main cargo routes[2]. There are seasonal difficulties in the navigability of rivers and canals for the traditional country boats that constitute the great bulk of the merchant fleet, but geography and history have made these craft the preferred means of moving goods between the ports on the Bay of Bengal and the interior and between surplus and shortage regions of the country. As of 1987, the Bangladesh Inland Water Transport Corporation operated a fleet of more than 480 vessels; about half were inland and river barges, and the rest were used for coastal trade. The size of the corporation's fleet had been steadily declining over the years, but they still represented a substantial portion of the registered watercraft.

The total number of passenger- and cargo-carrying country boats plying the vast river system was nearly 300,000 and was increasing in the mid-1980s. Some of the larger boats use a single sail to supplement manpower. The larger boats carry loads up to thirty-five tons and operate with crews of three or more. Generally, they are built with a raised platform at the stern of the vessel, on which a man patiently walks back and forth with a large-paddled oar, while others may pole in the shallow water or row from the sides. At times, the boats are pulled with ropes from along the shore. These boats have a shallow draft, necessary for navigating in the extensive but very shallow river system. When loaded, the boats sit low in the water. Cargoes of raw jute or logs from the mangrove forest of the Sundarbans may fill all the interior space and project beyond the gunwales of the boat itself. Other cargoes may be bagged or covered with cloth or bamboo meshwork. Country boats are estimated to move more than 17 million tons of cargo yearly, on a system of at least 1,400 launch landings and the major river ports of Dhaka, Narayanganj, Chandpur, Barisal, and Khulna. Country boats are unsuited for the Bay of Bengal or the broad Padma-Meghna estuary. Thus coastal traffic of bulk agricultural goods is much smaller than inland waterway traffic.

Traditional and modern means of water transportation meet at the seaports of Chittagong and Chalna, where most of Bangladesh's imports and exports

are transferred between dramatically different kinds of vessels. The government-owned Bangladesh Shipping Corporation reportedly had twenty-one oceangoing ships in its inventory in 1986, and the ships of many other nations called at the major ports. Chittagong, the principal port, has an excellent natural harbor and anchorage on the Karnaphuli River, about five kilometers from the Bay of Bengal. The port facilities were developed after 1947, and by 1970 Chittagong could berth 20 ships at a time and handle 4 million tons of cargo annually. In 1985, the port at Chittagong handled some 1,086 vessels and 6.2 million tons of cargo. Chalna is on the Pusur River about 64 kilometers south of the river port city of Khulna. Chalna was still being developed in the late 1980s, but it was rapidly gaining on Chittagong in capacity and in traffic, particularly as land and inland waterway connections also were being improved to reorient the distribution system of the west and northwest areas of the country to the newer port. The port at Chalna handled 545 vessels and 2.3 million tons of cargo in 1985.

The landscape of Bangladesh is dominated by about 250 rivers providing over 5,000 miles [8,000 km] of navigable waterways. Country-made boats are the most widely used carrier one can see in the rivers and rivulets. They carry passengers and merchandise on a large scale. Mechanized Water transport is mainly operated by the Bangladesh Inland Water Transport Corporation (BIWTC), which run ferry and launch services on the main routes. There are also water transport services run by private companies

1.2- Length of water ways.

Bangladesh lies at the apex of the Bay of the Bengal with rivers flowing down from the surrounding countries. Nearly the whole area of the country consists of low and plain lands 24,000 km long network of inland waterways. Three major river systems and their confluence form the world's largest delta. Bangladesh has about 9,000 sq km of territorial waters with about 720 km long coast line and about 20,000 sq km of Economic Resources Zone (ERZ) in the sea. About two-thirds of the land is vulnerable to flooding and most areas remain under water for two to five months in a year. As a result, costs of development and maintenance of roads and railways are comparatively higher. On the contrary, inland water transport has always been a natural and relatively cheap means of transport in Bangladesh. In certain areas, it is the

only mode of transport. Including the country's unclassified routes, the total length of waterway (700 rivers) is about 13,000 km. Of the total waterway, 8,433 km is navigable by larger vessels in the rainy season (5,968 km of which is classified for navigation), reducing to about 4,800 km in the dry season (3,865 km of which is classified) [1].

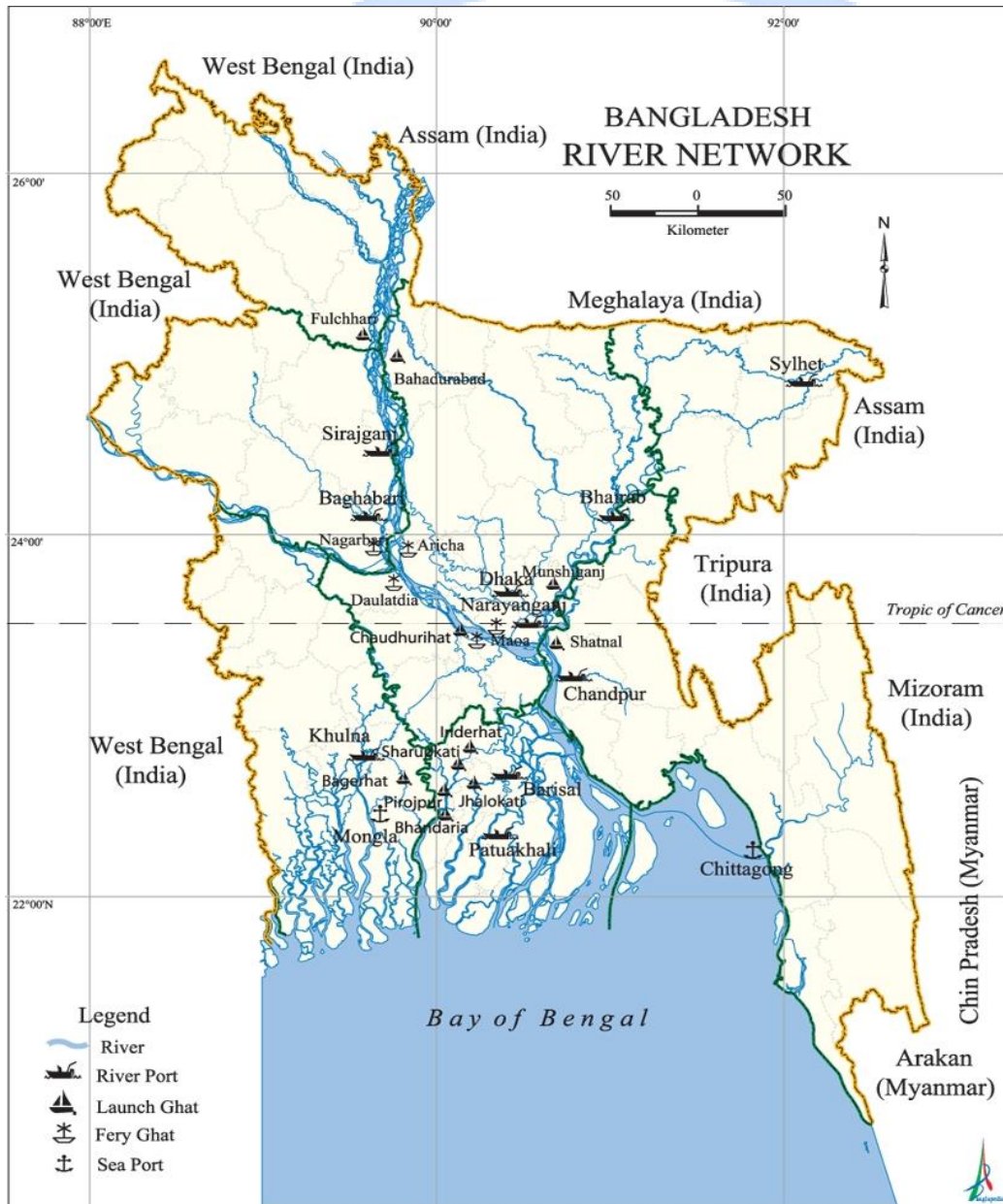

1.3- Classification of water ports.

Presently two organizations: Bangladesh Inland Water Transportation Authority (BIWTA) and Bangladesh Inland Water Transportation Corporation (BIWTC) control the marine vessels ply in the inland river-ways and the river ports of Bangladesh [3]. The inland navigable waterway routes as classified by BIWTA fall into four groups:

Class-I:	Four trunk routes (depth 3.66 m - 3.96m, length about 683 km) Chittagong-Chowkighata-Chandpur-Shambhupura-Narayanganj/ Dhaka; Shambhupura-Demra; Shambhupura-Bhairab Bazar/Ashuganj; and Chowkighata-Barisal-Mongla-Khulna-Maheswarpasha.
Class-II:	Eight link routes (depth 1.83m - 3.65m, length about 1,000 km) Mohanpur-Daikhawa; Bhairab Bazar-Chhatak; Chalna-Raimongal; Hijla-Saistabad; Satnal-Daudkandi; Chittagong-Cox's Bazar; Diara-Barisal via Nandir Bazar; and Chandpur-Ichuli.
Class-III:	Twelve secondary routes (depth 0.91m - 1.82m, length about 1,905 km) Dilalpur-Fenchuganj-Zakiganj; Chittagong-Kaptai; Rangamati-Kaptai; Kaptai-Belaichari; Rangamati-Chotohorina; Rangamati-Mahalchari; Rangamati-Marisha; Sripur (Bhola)-Nazirpur-Char Montaz; Jhalakati-Barguna-Patharghata; Charpower-Patuakhali-Galachipa-Bara Baishdia; Bara Baishdia-Khepupara-Mohipur; and Khulna-Bardia-Manikdah.
Class-IV:	Seasonal routes (depth less than 0.91m, length about 2,380 km). No LAD is maintained for these routes.

Without this 4 class According to BIWTA, there are 374 places have so far been identified where BIWTA does not have any establishments. Those ports are used to load and upload the goods and passengers. In addition, there are eight ferry jetties which are used for the transportation of motor vehicles carrying goods and passengers [1].

1.4- system of water transportation in Bangladesh.

In order of importance, Bangladesh's three major ports are Chittagong, Mongla and the Dhaka-Narayanganj complex. Chittagong handles about 76% of the country's 10 million tons of annual foreign trade. Mongla port is yet to fulfil its obligation due to problem of siltation at the approaches to the berths and hinterland access. Though the port was designed for a 7.5 metres deep approach channel, yet due to siltation the requisite draft is not available except during the high tide only. The Dhaka -Narayanganj port complex is handling an increasing volume of traffic, growing from 1.6 million tons in 1980 to about 8.00 million tons now of which around 45% are sea-borne. The potential for container traffic at this port is presently some 200000 tons and could grow to over 500000 tons by the year 2000, if adequate container facilities are provided. There are potentials for growth in container traffic and possible establishment of an international port of call at Dhaka. Bangladesh Flag Merchant fleet has 14 Vessels of Bangladesh Shipping Corporation and 11 at the private sector currently. The total DWT capacity of the Bangladesh flag vessels (public/private) is only 0 .338 million MT now. Bangladesh flag vessels currently transport less than 5% of our general cargo movement of our foreign trade, although UNCTAD code of conduct for liner shipping conferences provides for up to 40% of the country's liner trade to be carried by National Flag Vessels. A recent UNCTAD study, however, shows that the



Developing countries without their own merchant fleet usually pay 8-10% higher freight rates than the countries with their own fleet. Shipping should be treated as an export-oriented industry and given all kinds of support for development. Container traffic at Chittagong port is growing at the rate of 34% per annum and is expected to reach a level of 287400 TEUs by 2000. The container terminal at the port always remains congested because of poor

dispersal of traffic to Dhaka area, which accounts for 60% of the total traffic. Contributory factors for the stagnation are; inadequate handling equipment at the multipurpose container terminal at Chittagong, shortage of container wagons and locomotives to reach containers to Dhaka terminal and inadequate infrastructure for providing door to door service to customers. Inland Water transport is one of the oldest modes for economically efficient and environmentally sustainable transport system of the country. Inland waterways are a critical component of the Bangladesh transport system in view of the floods, which regularly affect the country and disrupt the other two surface transport modes. The inland waterway network comprises over 8300 km of navigable waterways during the monsoon season, a reduction to about 5200 km occurs during the dry season. More than half of the country's total land area is situated within a distance of 10 km of navigable waterways. This network of waterways carries about a third of the total freight to km, and approximately 13% of all passengers use Inland Water Transport. A major problem affecting inland water transport is the shrinking of the navigable network due to both siltation and reduction in the amount of water available during the dry season. The inland waterways include some 11 major and over 100 minor ports and about 700000 river vessels are operating in the country. Most of these ports are impaired by inadequate facilities for mooring and unloading vessels and for storage of goods as well as by siltation of approach channels. These problems are compounded by the changing morphology and unpredictability of the rivers, which often change course, erode embankments and generally endanger fixed riverfront infrastructure. Substantial increases in budgetary allocations for dredging and in the productivity of the dredging fleet are needed the country where rivers carry 2000-2500 million tons of silt a year in that country there has not been added even a single new dredger in last 24 years time. There are altogether 35 dredgers, of which 27 are under Bangladesh Water Development Board and the rest 8 are under Bangladesh Inland Water Transport Authority. Surprisingly two dredgers were built in 1950 and were used in digging the Suez Canal. The total quantity of silt dredged in 1995-96 by IWTA was 104.76 million cft, while BWDB dredged 65.20-million cft of silt during the same period. In 1996-97 IWTA dredged 126 million cft of silt and BWDB dredged 88.60 million cft of silt. [8]

1.5- Lacking in water transportation in Bangladesh.

The landscape of Bangladesh is dominated by about 250 rivers providing over 5,000 miles [8,000 km] of navigable waterways. Country-made boats are the most widely used carrier one can see in the rivers and rivulets. They carry passengers and merchandise on a large scale. Mechanized Water transport is mainly operated by the Bangladesh Inland Water Transport Corporation (BIWTC), which run ferry and launch services on the main routes. There are also water transport services run by private companies [9]. But how many of them are well equipped? Very few of them have electric rudder system. Where every single launch or ferries or ship should have rudder and other electric facilities by which it can accurately measure the distance around. Not only the distance measurement but also the weather report facilities and fish net detection facilities should have on these ships. For these lacking in water transportation system Bangladesh water ways are lagging behind.

1.6- Causes of water ways accidents.

We know that our country is a land of natural calamity. So during the travel in the water ways one can't predict the nature's intention without having any digital equipment or weather forecast. These days the world leading status shows that every year more than 100 accidents have been happening because of lack of digital equipment or negligence of the driver about the weather. Most of the time the news has effect on the image of the Bangladesh, and people starts to avoid the water transport system for a while[5]. Those accidents create a big impact in economy also. Basically these accidents happened-

- Water vehicles had stuck in the river surface due to not detecting underwater surface during its journey. As we know that the river has poli which gathered in one place and build a underwater surface and then it will became a large scale upper water surface. During the process of the upper surface raising the underwater surface stay hidden

in the water. As a result it's impossible to detect in by normal eyes. So many ships, ferry, boat get stuck by them.

- Bad weather and drivers often does not listen to weather forecast. Bangladesh is a natural country of disasters. Weather change like mode swing of a person. Because of the monsoon season the country faced many turmoil natural calamities. Therefore, the weather forecast is more important than anything in the first time of the morning. But the driver who monitored those water vehicles often does not listen to the weather forecast. As result the accidents happened.
- Old equipment for the vehicles. Most of the water vehicles created from the old vehicles it's because new equipment cost money and old one is cheap and easily available. So the same equipment used again and again.
- Old docking system which requires the driver's accurate observation. The dockyard basically in Bangladesh 40-50feet long and many vehicles stationed there during the travel so to station a vehicle a driver has to have a accurate vision of landing its own vehicle else it will clash in the dockyard.
- Over excessive passenger. During Eid or Puja or any other national festival the people tend to celebrate it with their family as a result the transportation get overwhelmed by the passenger. The water transportation is cheap and comfortable so anyone can travel. Most likely middle class and poor people travel through the water transport and this result overrated passenger. Because of this sometimes vehicles tends o get drown in the way.

- Lack of awareness. As of now we are under developing country and many people is under illiterate position. Most of them do not follow rules and regulation because most of them do not know them very well. So they lack the awareness of the stay safe.
- Less knowledge of the equipment. Many drivers who tend to drive the vehicles sometimes do not carry the license or have the experience. As a result they lack the knowledge about the equipment.
- No modern system like digital map, satellite, GPRS etc.
- Wreckage in the vehicles. There is no system found to detect the wreckage in the vehicles. As a result many vehicle board without knowing there danger in the position.

Inland Water Transport plays a very significant role in the transportation system of Bangladesh. Its low expenses and high accessibility, as compared with other alternatives, amplifies a great demand for carrying goods and passengers within the country. Although water transportation sector in Bangladesh possess geographical advantage but there are deficiencies in the safety aspect. This study has been aimed at collecting and analyzing data of water transport accident that occurred in the inland waterways of Bangladesh during 1995 to 2005. A total of 177 cases were considered for the study which primarily included accidents of passenger and cargo vessels. It has been observed that the number of accidents increased significantly over the years and most predominant causes of accidents were found to be overloading, cyclone and collision. Several recommendations have been put forward with a vision to develop a safer and sustainable water transport system for the country.

Also there are 5,150–8,046 km (3,200–5,000 mi) of navigable waterways (includes 2,575–3,058 km or 1,600–1,900 mi of main cargo routes).

Because of Bangladesh's many rivers, ferries are a major form of transportation. These ferries are notoriously dangerous. They are often overloaded, and they continue to operate during rough weather. Hundreds of people die each year in ferry accidents. Many types of boats are also used for transportation.

Thus no one can go against the nature, but still by listening weather forecast one can save many lives.

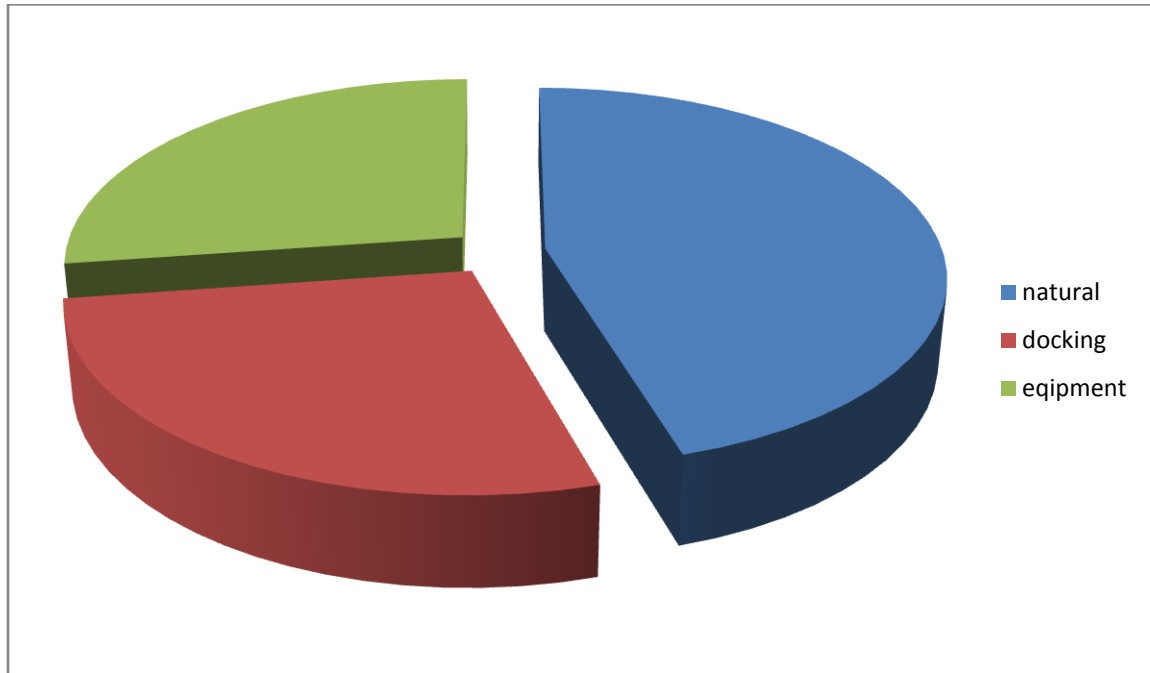

Three major types of accidents were identified in this study, such as overloading & cyclone (natural), docking; equipment failure shows the distribution of accidents. It is quite evident from the analysis that overloading & cyclone (50%) is the major cause behind the accidents. On the other hand, 30% around of rest of the months the frequencies of accident were nearly cause for docking and the rest is for equipment failure.



1.7- how can government stop those accidents.

As result the accidents often happened and many people died. Many people lost their relative and also property. To stop these accidents happening government must take some steps like

- Digitalization of the water vehicles. Equipment such as GPRS, underwater surface detecting system, satellite phone must include these vehicles. Also peer to peer connection needs to start up those vehicles so that when one of them is in danger the other vehicle which is nearby can also help them to survive.
- Rules and regulation for the passenger carrying in a vehicle. Everyone must follow the rules that abide by the government and government must strict the rules and punish those who does not follow them.
- Increase awareness. Increase the awareness among the people who are poor and illiterate. So that they can learn their right and save their life's.
- Increase the education value to increase the knowledge.

- Create a monitoring system for monitor the overrated passenger in a vehicle so that the vehicle does not carry more than its can carry.
- Also to save the river pathway from the underwater surface government need to take steps to remove those poli from filling up.

1.8- what is docking and what type of accidents happened because of docking.

Among the reasons for the accident, one of them is safely landing in the dockyard during docking vehicles. To docking a vehicle it need proper accurate observation and experience of the driver. 30% of the accident happened because of the docking. Most of the vehicles are stationed in the port during the docking if the measurement of the proper place gets wrong then its impact on the vehicles immediately. Not only in our country but also the other countries faced problem during docking. Recently an accident happened in the Venice during the docking of the cruise ships in the dockyard (article-*Msc Preziosa urta finger, polemica a Venezia, The medi telegraph, 05April, 2014*)[10]. Although the ship's captain was present the accidents still happened. To stop any kind of the accident because of the docking we have come up with our thesis project "Automatic Docking using Sonar".

In our project we have used (HC-SR04) sonar to detect the dockyard and measure the distance for the safety docking. The sonar detects the dockyard and then it will help the vehicles to move left and right using propeller to safely docking. This project was based on a small boat that's why we have used the small air sonar.

Chapter 2: Objective:

The project is based on the water vehicles and it only helps the vehicles to solve some problem. The main purpose of this project are-

2.1 Detection system

Provide a detecting system for the water vehicles which will help the vehicles to detect anything like water surface, water vehicles or the dockyard. While the water vehicle is running through the river or sea it faces currents and sometimes different obligations such like small boats, fish nets, soil etc. So a detection system is mandatory for the water vehicle.

2.2 Safety docking

Provide a safely docking using the distance measurement system using the sonar(HC-SR04), which will help the vehicles detect the dockyard within the certain range and then dock it using a safe distance. After long journey of whole night the captain of the ship is so tired to dock the ship perfectly its cause's accidents many times while docking. By using this sonar the captain can easily measure the distance to dock yard. This way it will prevent the crash in the port and dockyard.

2.3 Digital display

Provide a screen to see the distances between the dockyard and the vehicle so that the monitoring person will understand if anything is wrong. And provide an autonomous docking system without the help of the vehicle driver.

2.4 Cost effective

Provide a cost effecting system for the water vehicles. So that anybody can use it for their water based vehicles. In our river land country there are so many people who have their boats, some private launch and ferries. But couldn't effort to buy costly equipments. For these reasons cost effective system should proved in these people for better future of our country as well as the safety in the water ways.

2.5 Digitalization

Provide a digitalized system for the old docking system. Actually for this old docking system there are many accidents occur. So these old docking system should be changed immediately. Digitalization of the docking system provides everybody a safer and comfortable journey through the river or sea.

2.6 Out of stress

The system works own it own and its does not required the attention of the driver all the time. So during rainy days or in the fog driver does not have to stress about saving his vehicles from drawn. Also at night he may get some sleep due to having no stress of landing.

2.7 Provide fewer accidents

As the system made the vehicle to travel and have its own detecting system. It's required less help from the driver. So it's a safe journey wherever its goes. As a result the percentage of the accidents may decrease in a good way. Therefore it will help to reduce the negative image about the accidents of the water vehicles in Bangladesh. That way the good image of our country will provide a better impression in other country and which may attract the tourist to travel through the water vehicles. Furthermore if we can increase the tourism it may help the economy. May be in near future the water transport system may become one of the largest tourism site because of the safety of the people.

Chapter 3: Literature review:

3.1 Automatic docking system

Automatic docking has been used in many places but most of the work of the automatic docking is used in the space station. Automatic docking system like IGLA, KURS, and NASA docking system are famous for their docking in the space. This system is being used in the space from a very long time ago. The **Igla** (Russian: Игла, "Needle") docking system was a Soviet radio telemetry system for automated docking of Soyuz spacecraft. The first prototypes were made in late 1965. On 30 October 1967, the first automated docking of Soyuz unmanned spacecraft took place.

Kurs was the successor to the Igla system and today provides navigation beaconing for Russian space vehicles including the Soyuz spacecraft and Progress spacecraft. Kurs provided the automated docking system for all Russian spacecraft that docked with the Mir space station [12][13]. When used for docking, the Soyuz or Progress vehicle broadcasts radar pulses from multiple antennas. The variation in strength between the antennas allows the system to compute relative position, attitude, and approach rate. The system is designed for automatic rendezvous and docking, but in emergency cosmonauts may take command of the vehicle either locally, or from the International Space Station [14].

After the dissolution of the Soviet Union in 1991, the Kurs system became the property of Ukraine; its manufacturer became a competitor in the space launch business with RKA. Due to hard-currency problems, Kiev also raised the price of the Kurs system. Consequently, RKA sought to phase out its use in its vehicles [15].

The NDS (NASA docking system) docking mechanism is androgynous, the first system to use low impact technology and the first system to allow both docking and berthing.^[16] It supports both autonomous and piloted dockings and features pyrotechnics for contingency undocking. Once mated the NDS interface can transfer power, data, commands, air, communication and in future implementations will be able to transfer water, fuel, oxidizer and pressurant as well. The passage for crew and cargo transfer has a diameter of 685 millimeters (27.0 in), which can be increased to 813 millimeters (32.0 in) by removing the petals of the capture mechanism after mating.^[17]

3.2 Project used for Water docking system

For the water docking system there are project which only focused on the autonomous water vehicle. For example the “**An Autonomous Surface Vehicle for Water Quality Monitoring**” is a project based on the water vehicles which is published from the Australasian Conference on Robotics and Automation (ACRA), December 2-4, 2009. This project describes how an autonomous water vehicle can travel from one place to another without the help of anyone. It’s basically wireless based project which take order from a certain computer or mobile phone. It sends its signal to the mobile using GPRS and then it’s automatically dock in the certain place.

The ASV project is capable of the navigating throughout the complex inland water storages and measuring a range of the water quality properties. The project was solar powered. A unique feature of this ASV is its integration into a storage scale floating sensor network to allow remote mission uploads, data download and adaptive sampling strategies. Also the vehicle was designed using to control itself.

3.3 How ASV helped our project

The ASV project helps us to understand how vehicles autonomously work and using solar power how can it get energy to float. But this project is only focused on the measurement of the water quality for the green house effect. So for our project the ASV project was only helping to understand the navigation system.

There are many project based on autonomous water vehicle there are very few project in the docking system for the water vehicle. Most of the article which covers the docking system is for the space craft. So after getting some ideas from the auto docking system we have used it in our project.

Chapter 4: System implementation

The project was to detect the dockyard and safely dock that why we have used the sonar.

4.1- How will it work (picture and explanation)

How the whole project works it can simple explain by some picture-

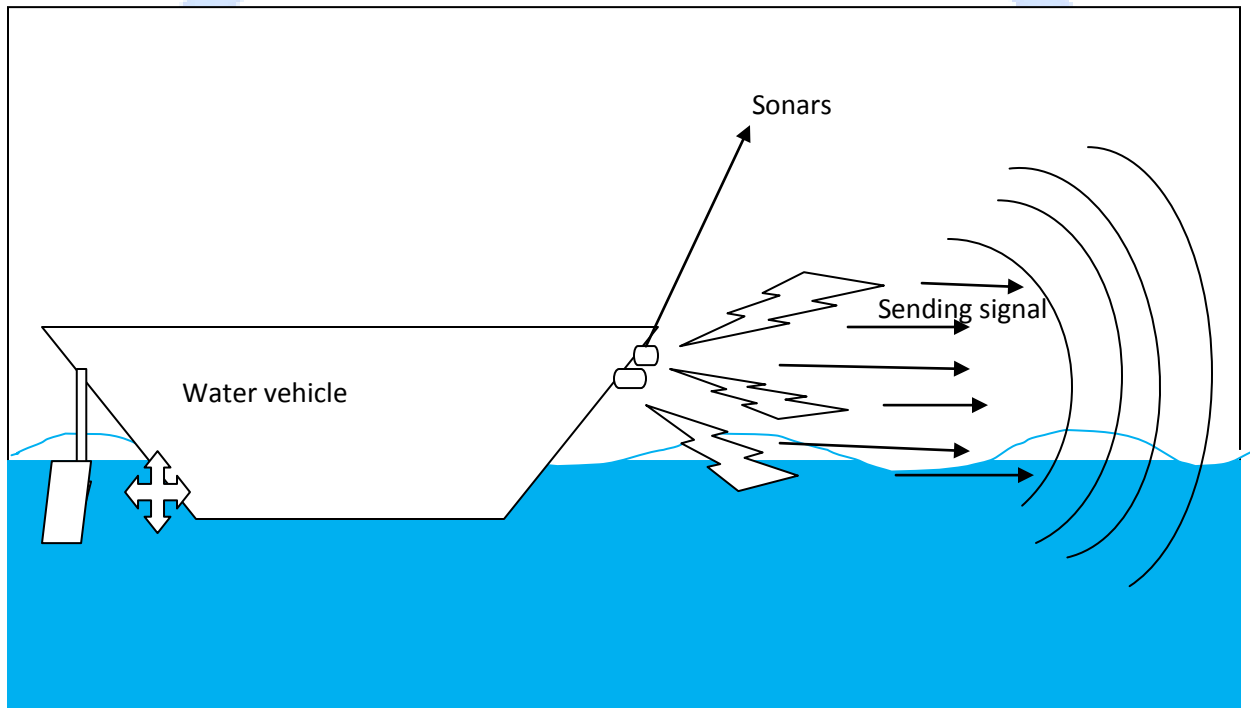

Figure-a

(Figure-a) shows that after triggering the sonar has send the signal throughout the air to find the object that the sonar has been searching for. When the sonar send the signal the signal each of them carry 8 different signals and its spread the surrounding in 30 degree angle. It search through the area of the 2-400cm.

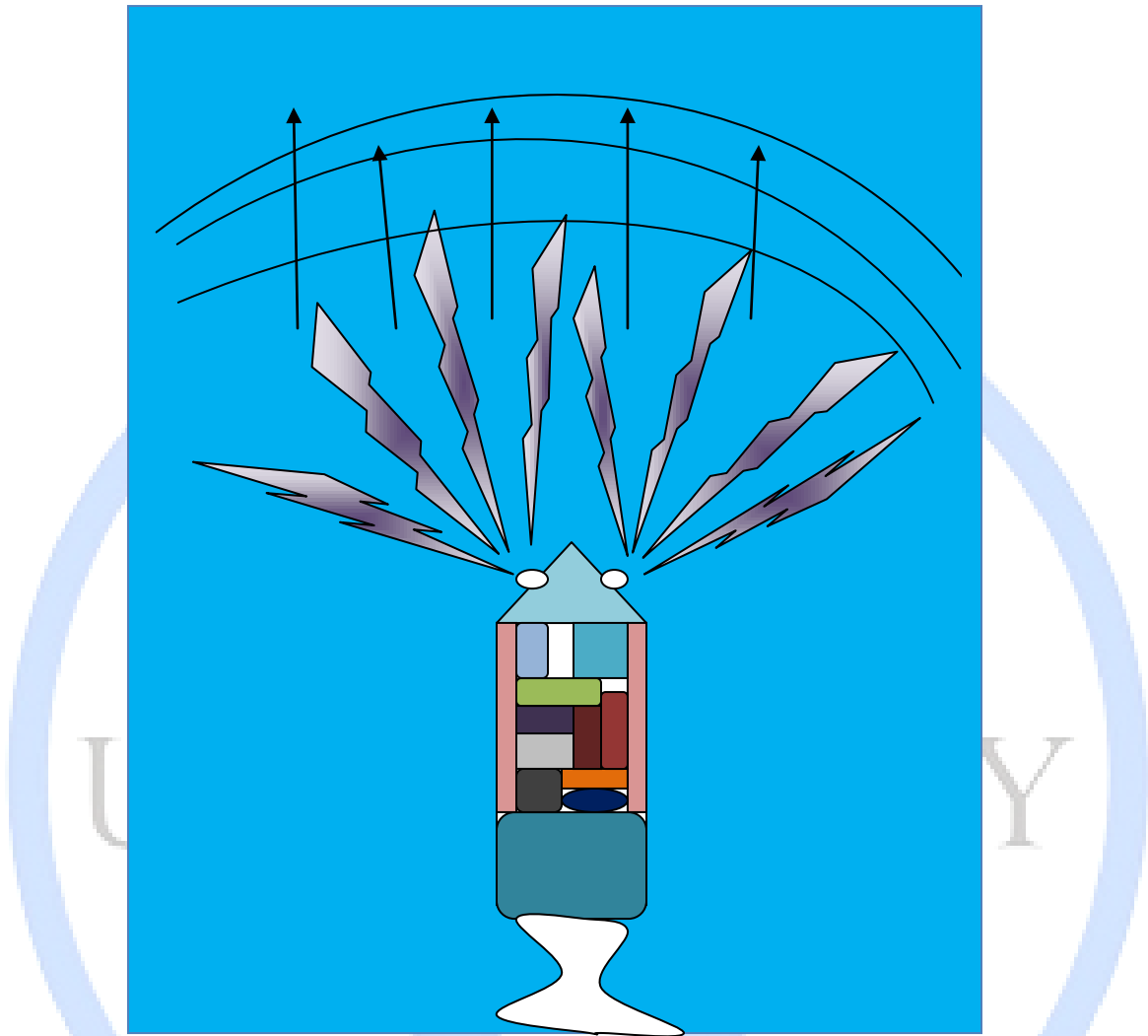

Figure-b shows that the upper view of the boat that is sending signal for searching the dockyard. The signal can go through the water also and that way it can also detect underwater surface and inform it to the driver to avoid collision.

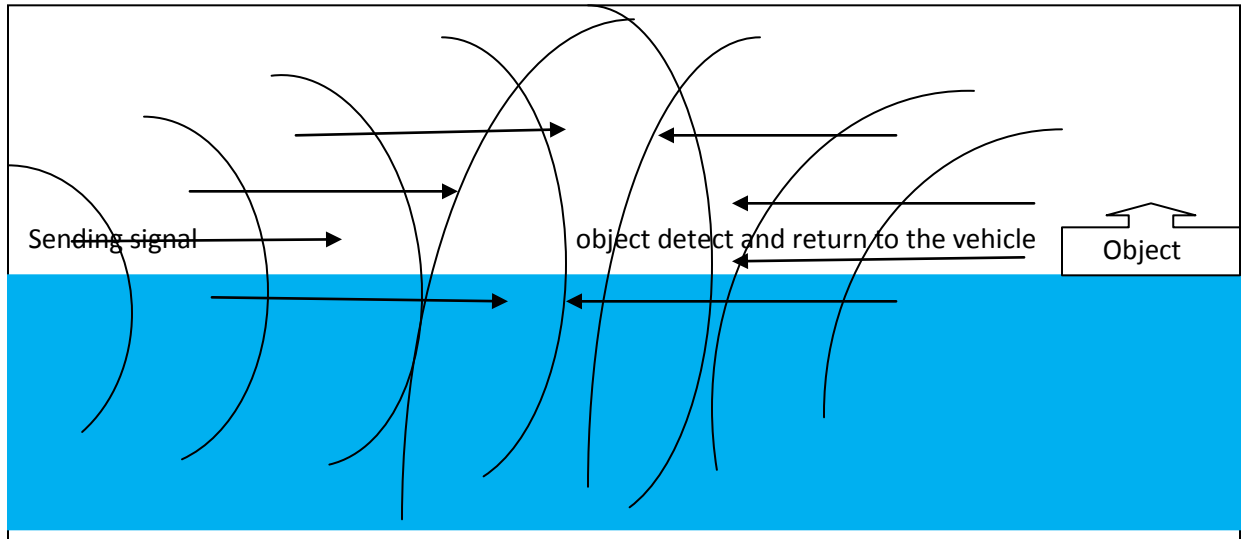

Figure -b

Figure-c shows that after detecting the object the signals return to the vehicles to report it to the main system. The object have to be within the range 2-400cm. after detecting the object the signal transform into the returning receiving signal and go back to the base.

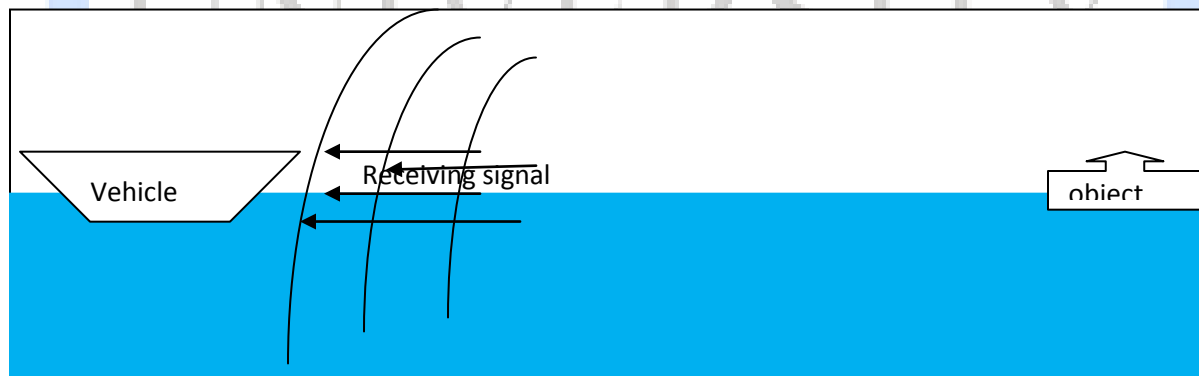

Figure-c

Figure-d shows that the vehicles receiving the signal. Sending it to the ships there the system show it to the LCD monitor and the system make the vehicle automatically move right or left to match the both of the sonar distance and then finally it can dock in the dockyard.

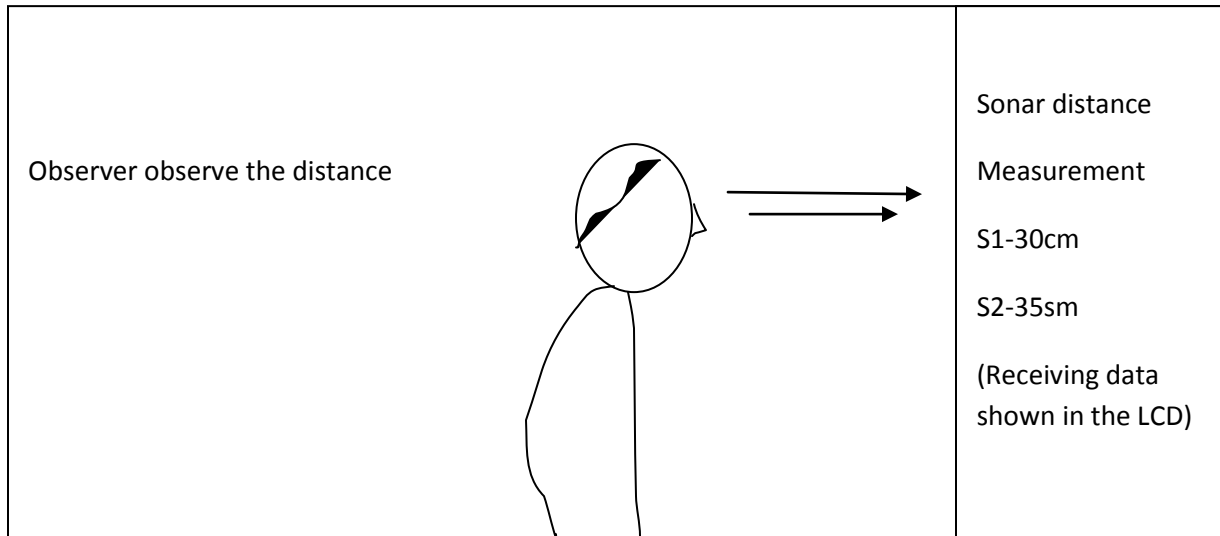

Figure-e shows that the driver is learning about the distance difference of the both of the sonar.

After getting the value the vehicle move forward and then decide to fix the both of the sonar distance. For docking both of the sonar needs to be in the exact same distance. That's why the boat move left to right to fix the distance. When both of the sonar will be in the same distance within the 10cm the propeller will stop and by the time it will be done with docking.

The system was designed by 3 phase they are-

- Hardware part
- Circuit part
- Control software part.

4.2 Hardware part- the hardware part consist of two steps they are

- First step
- 2nd step

4.2a first step-first time for the boat making we have used a 2 feet long and height is 8 inch PVC boat. Our main goal was to float the boat into the water. Since we have used the boat we have learn that the boat needs to curvy under it body to slide with the water.



4.2b 2nd step- then the figure of the boat has been made using the aluminum sheets. We have taken only 2 feet long of the aluminum with the height of 10 inch. Which have back side width 11inch and front side width 10inch to make the body of the boats. The propeller and control gear also made from

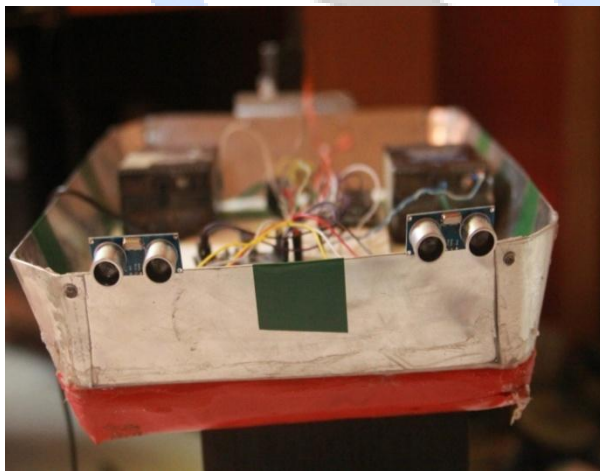

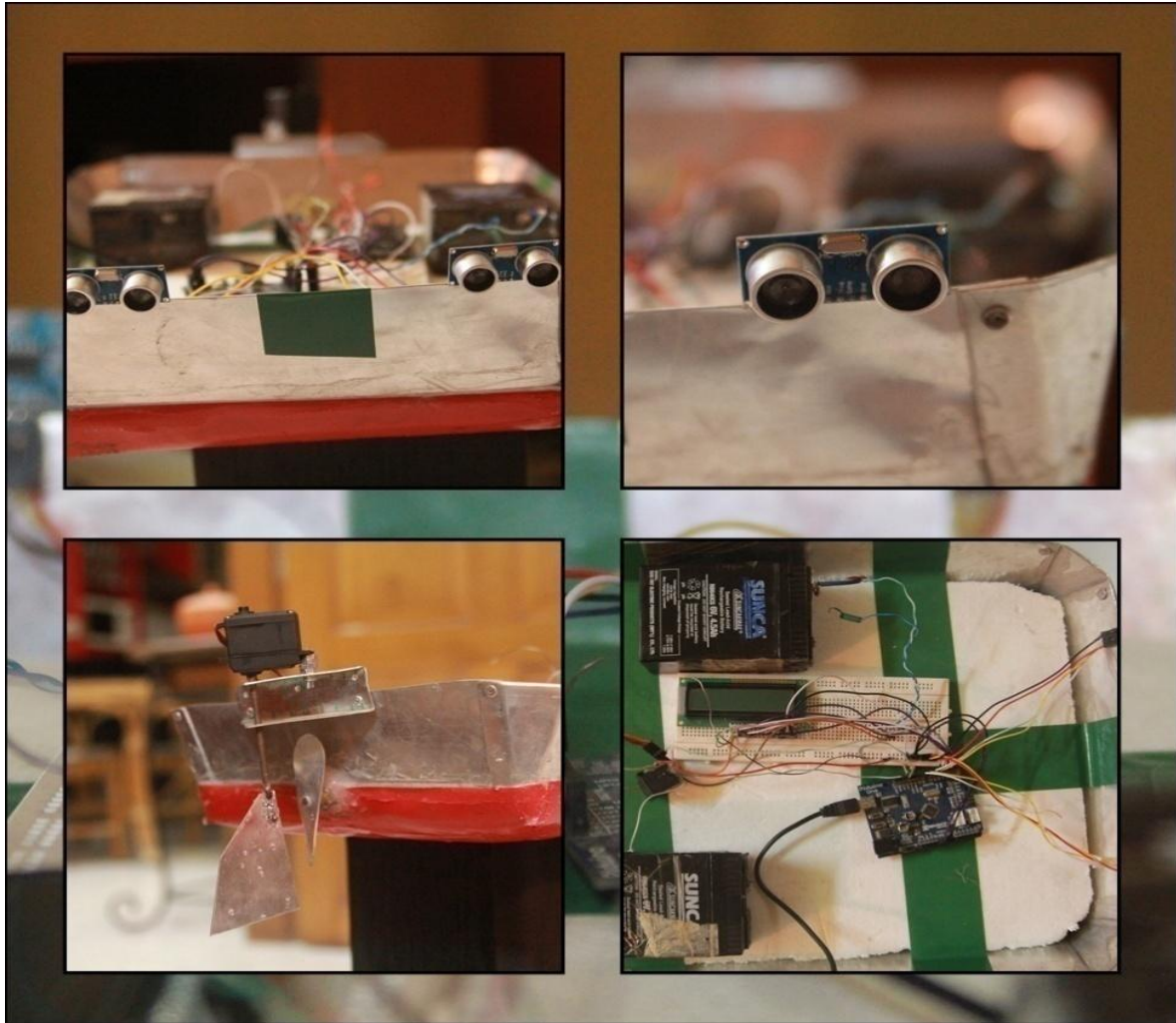

the aluminum. We have used shola under the boat to prevent it from downing and inside the boat to prevent current from flowing all over the boat. Then to make it water proof we have used silicon to fill up hidden gaps, if the gaps were there then our boat have been drawn.

4.3 Circuit part- the figure of the circuit have been shown by the diagram

The circuit parts provide the whole diagram of the connection and how it works.

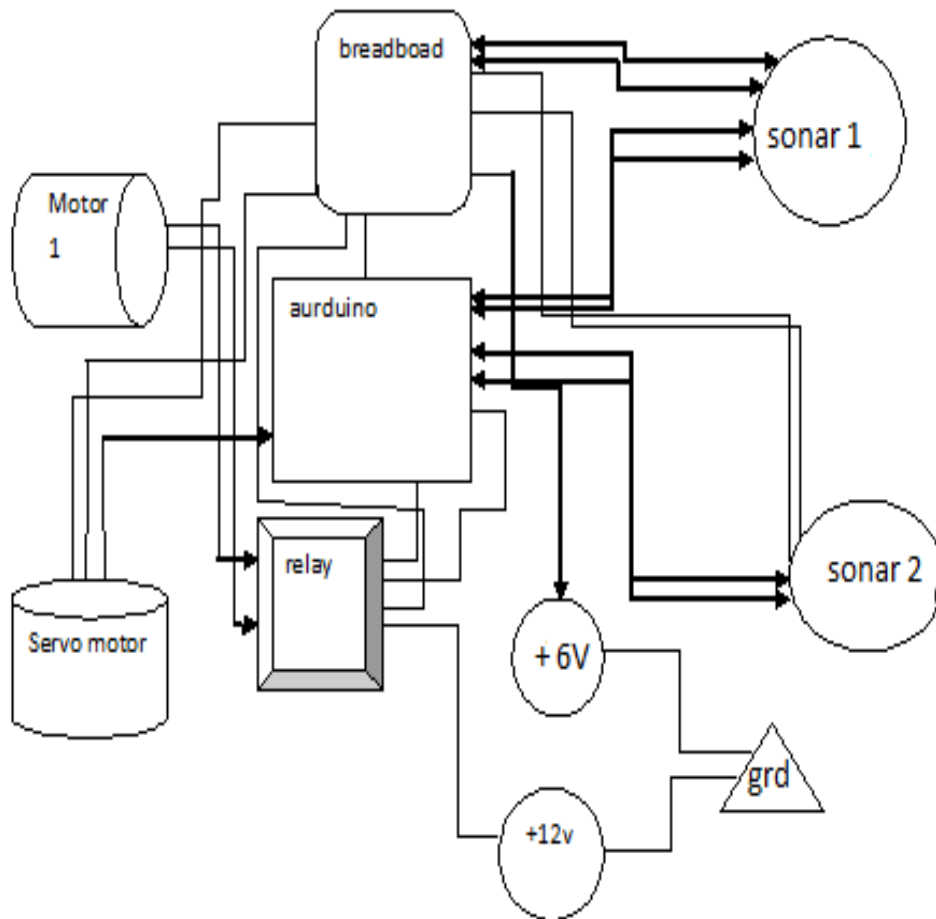

The arduino is the part where the coding for autonomous is being used. It requires 5v to charge on and a breadboard connection with the motors and LCD. 12v needed for the main motor and relay. 6v more needed for the servo motor. When the trigger is on the Arduino code runs the sonar the sonar send and receive the signal and the Arduino progress with further action with the help of the motors.

We have to take care all of the part of the circuit. The circuit was building up using the help of Aurduino. We have used 2 (HC-SR04) sonar. The basic principle for this sonar to work is –

- (1) Using IO trigger for at least 10us high level signal,
- (2) The Module automatically sends eight 40 kHz and detect whether there is apulse signal back.
- (3) IF the signal back, through high level , time of high output IO duration isthe time from sending ultrasonic to returning.

Test distance = (high level time×velocity of sound (340M/S) / 2.



To trigger the sonar we needed-

Power supply	+5VDC
Quiescent current	<2mA

Working current	15ma
Effective angle	<15*
Ranging distance	2cm-400cm
resolution	0.3cm
Measuring angle	30degree
Trigger input pulse width	10us
Dimension	45mm x 20mm x 15mm

The whole circuit was designed for the simple use that's why we have used as simple circuit.

The circuit required-

- 5v to power up the Arduino.
- 6V to power up the servo motor.
- 12v to power up the relay and main motor.
- 2 sonar for measure from left and right side of the boat.
- Relay is used for stopping the motor during docking.

The circuit is cost effective because we have focused on the people who can afford it. The sonar have 4 pins which connected with the LCD and arduino.

Pin Define

- 1: GND
- 2: ECHO
- 3: TRIG
- 4: VCC

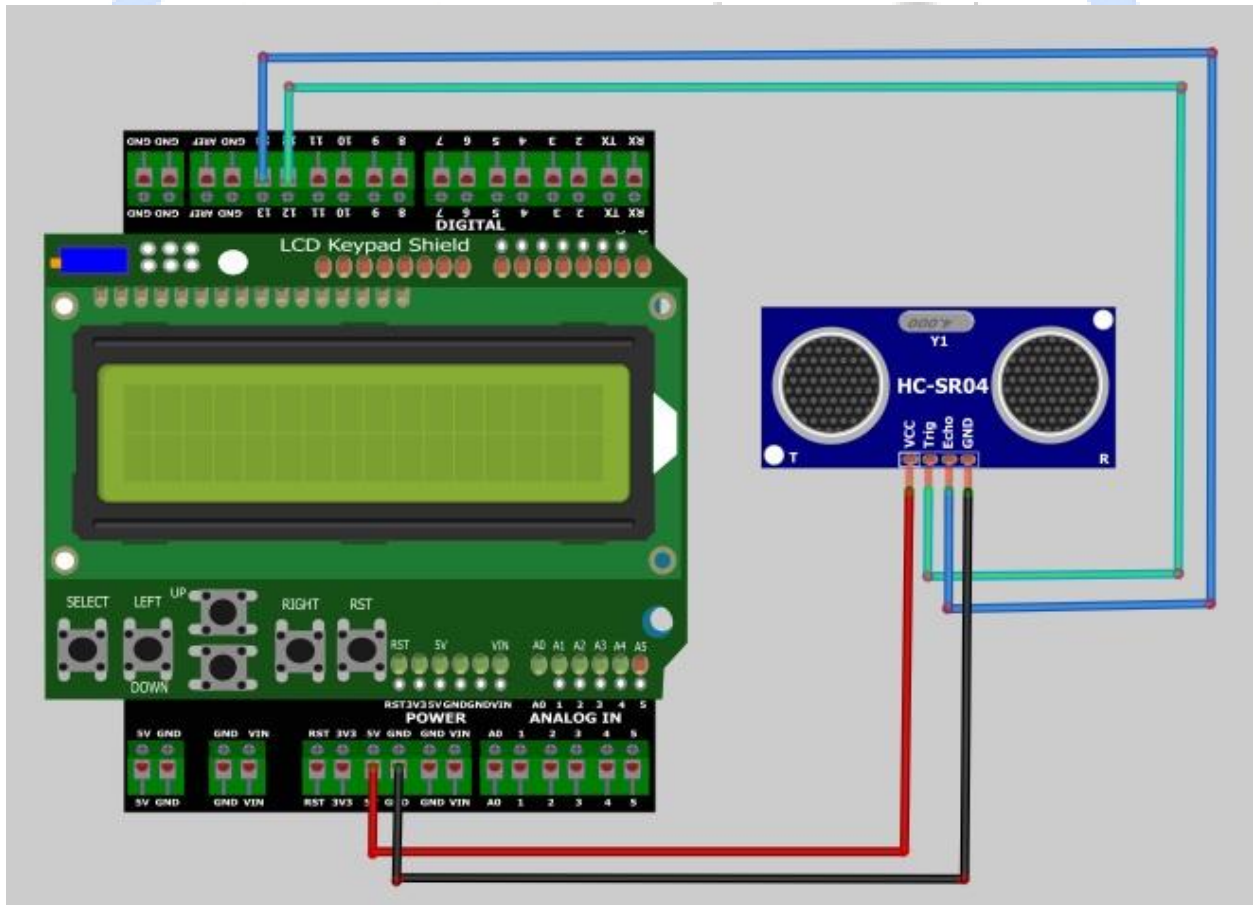
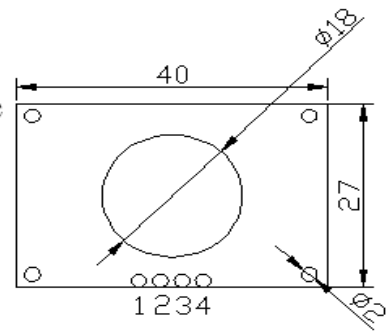

Figure-f shows how the sonar connect with the LCD

The sonar best work in the 30 degree angle and it send 8 signal per seconds

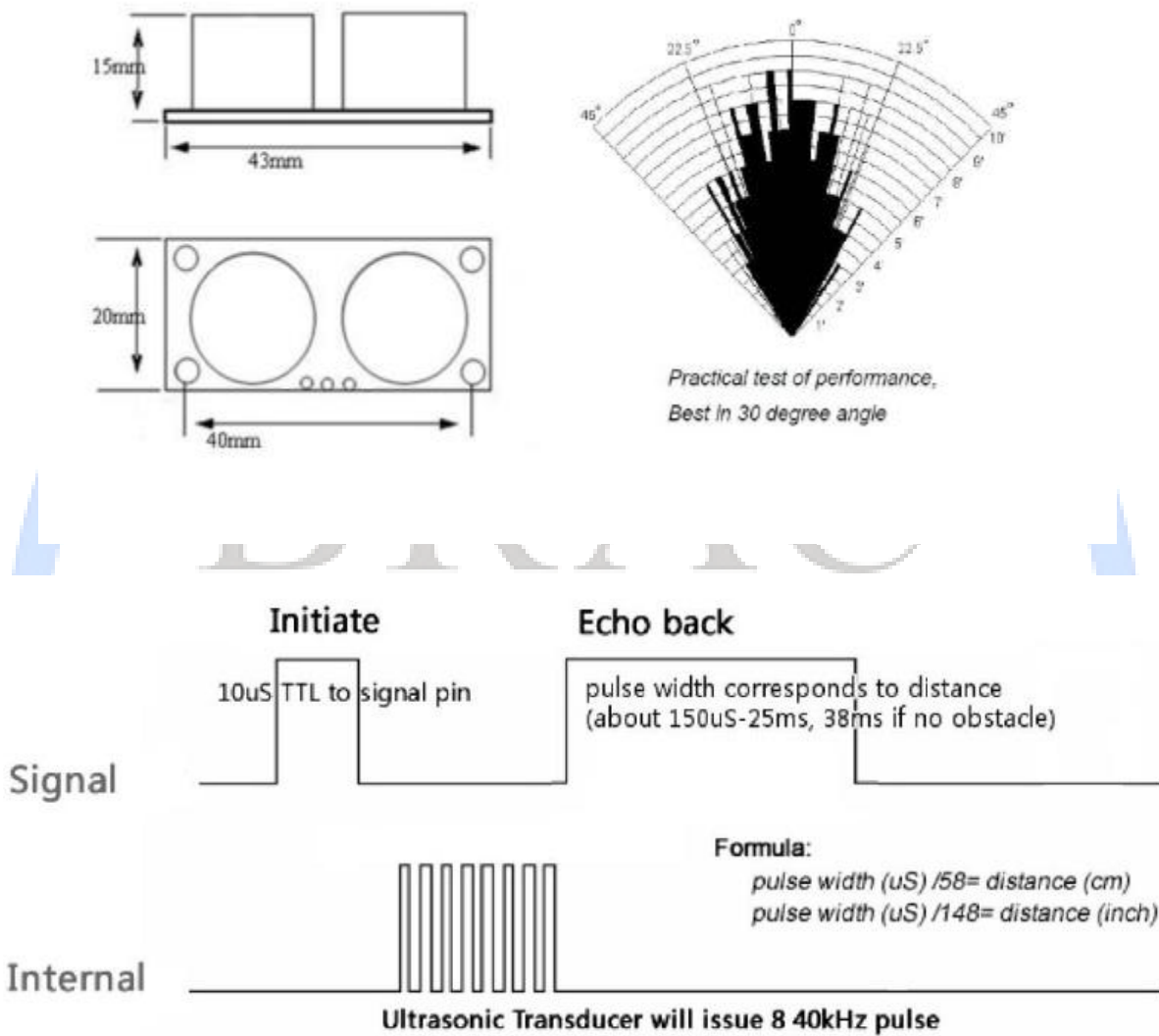
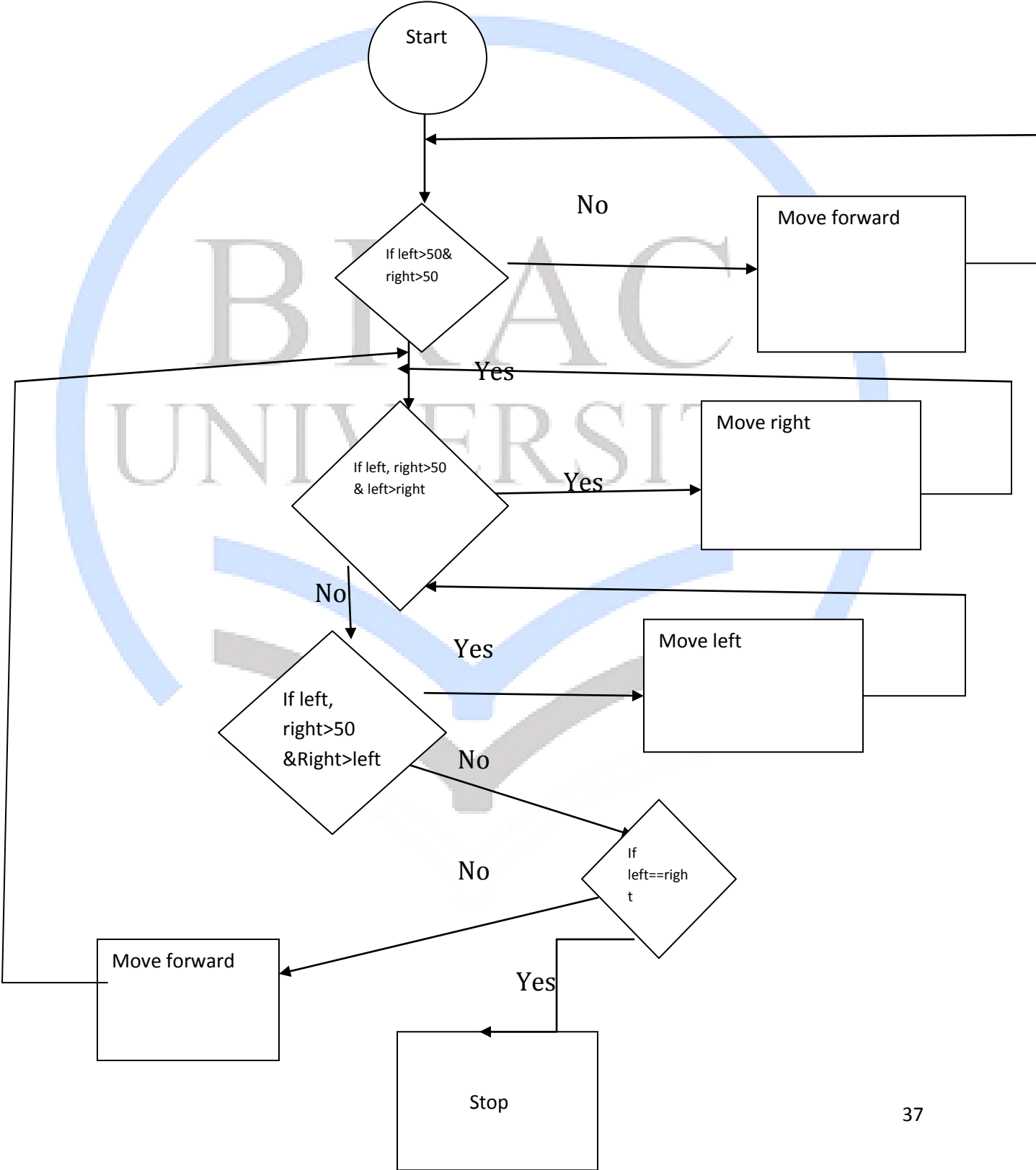

Figure-g shows the working pattern of the sonar

Control software part- the circuit was designed with a simple code only for the fixing the distance of the both sonar's. the flow chart is



Explanation of the circuit part-

when the vehicle is start the sonar goes on searching for the object within the range of the 400cm. if the object found within 400cm its move on to closer the object then the system check whether the object is in the rage of 50cm. if both of the sonar range is in 50cm then its check for the left sonar and right sonar value. If the right sonar is higher then left sonar then the ship will move toward the left and if the left is higher than the right sonar then the ship will move into the right. By this way each and every time the sonar will check until both of the sonar will be in same range. Then it will check that if the range is within the 10cm. if it's in 10cm the ship will stop and by the time it will be in the dockyard.

BRAC
UNIVERSITY



Chapter 5: Testing-

After power on, the module waits for the trigger signal. Triggered automatically issued within 8, 40 kHz cycle level, and to detect the long echo time, and through the corresponding timer output level TTL level PWM pulse width.

The Echo is a distance objects that is pulse width and the range in proportion .to calculate the signal we used a simple formula. Formula: $\mu\text{S} / 58 =$ centimeters or $\mu\text{S} / 148 =$ inch;
Or: the range = high level time * velocity (340M/S) / 2; Measurement cycle, in order to prevent trigger signal to the echo signals.

So if we start with the HC-SR04, it's an IC that works by sending an ultrasound pulse at around 40 KHz. It then waits and listens for the pulse to echo back, calculating the time taken in microseconds (1 microsecond = 1.0×10^{-6} seconds). We can trigger a pulse as fast as 20 times a second and it can determine objects up to 5 meters away and as near as 50cm. It needs a 5V power supply to run.

To start measurement, Trig of SR04 must receive a pulse of high (5V) for at least 10us, this will initiate the sensor will transmit out 8 cycle of ultrasonic burst at 40kHz and wait for the reflected ultrasonic burst. When the sensor detected ultrasonic from receiver, it will set the Echo pin to high (5V) and delay for a period (width) which proportion to distance. To obtain the distance, measure the width (Ton) of Echo pin.

Time = Width of Echo pulse, in uS (micro second)

- Distance in centimeters = Time / 58
- Distance in inches = Time / 148
- Or you can utilize the speed of sound, which is 340m/s

The LCD display shows the result of the finding object. Since the code was to detect the object within the 50cm. when the object will be within the 50 cm but the

Distance of the left and the right object will be different the vehicles will move on it's on to keep the both distance same. After the both distance are same but not within the 10cm it still will move on to forward. But when the vehicles will be within the 10cm of the object then the propeller will stop work and the motor will slow down for docking.

Chapter 6: Analysis and findings

We have found that-

- It is an easy to detect the object since we are using the sonar.
- Its move its own to match up the both of the sonar's object.
- The sonar also can detect the other object like other vehicles.
- Since we have used batteries we need at least 12v to move the boat.
- Some of the water may enter because the propeller is not water proof.
- It's easy to handle.
- It does not require accurate observation.
- Only a person can handle the whole system.
- Its needs to water proof because the water can damage the circuit.
- 5v power supply must be needed for the aurduino without it the boat will not move.
- It's cost effective.

Chapter 7: Limitations

- The sonar is not waterproof so anytime the sonar will get affect by the water and damage the whole circuit.
- The sonar may not detect the fish net so it will be a problem.
- The circuit was designed by the thinking of our small boat. But if we used it on real time boat it may need bigger sonar to detect the object.
- Since the water proof sonar is very reliable we need to discover a new kind of technology to avoid the water problem.
- The system requires computerized coding but the old boats does not have the computer it may create a problem.

BRAC
UNIVERSITY



Chapter 8: Discussion-

Almighty Allah in His infinite mercy blessed Bangladesh with its unique geographical location. Situated at the foothills of the great Himalayan range and washed by the waters of the Bay of Bengal, the land is covered by a vast system of rivers, tributaries, distributaries and other water bodies. These natural inland waterways course down the country; and from time immemorial the people have learned to depend upon the network as a natural means of transport and communication.

Unfortunately, due to continuous low priority given by Policy Makers to the country's inland waterways in comparison to other competitive surface modes, Inland Water Transport (IWT) infrastructure is not as well developed in Bangladesh as Roads and Railways. In fact, inland waterway routes have suffered a gradual decline not only in navigable length but also in service quality and safety standards.

The reason is very obvious. In comparison to the competing modes (Roads and Railways) drastically low infusion of funds in the Development Plans, Annual Development Programs, and Yearly Revenue Budgets spread the resources so thinly that even existing infrastructure does not receive proper repair and maintenance attention. The following two Tables display the issue eloquently and need no further elaboration:

The meager funding in the sector has already resulted in irrecoverable damage to its once thriving 24,000 km of navigable routes. At the time of the country's liberation in 1970, the navigable waterways measured about 12,000 km. Today there exist only 6,000 km of classified waterways, which further dwindles down to 3,800 km during the low water seasons. It means that 50% of classified waterways have been lost within a little more than forty years of self-rule.

Despite the prevailing critical conditions, it is to the credit of the Inland Waterways that it has continued to survive and is still able to serve the users who overwhelmingly belong to the underprivileged and poorer strata of the society.

Prospect of passenger movement

Bangladesh inherited five inland river ports in 1970. As the newly formed country geared up to re-build its war damages, development and economic activities accelerated. Consequently passenger and cargo movements increased. In order to meet with the demand, a number of new ports grew up; and today there exists about 23 officially gazetted main inland river ports. These are strategically scattered around the country and efficiently provides landing and handling facilities to the people, particularly to those living in remote rural areas and in coastal islands having no land connectivity with the mainland.

These river ports being the principal origin and destination points, the movement of passengers through them provides an indication of their existing activity. The current statistics disclose a growth of 0.05% which is not encouraging. The main reasons can be attributed to continuous infusion of massive doses of funds that resulted in (i) rapid growth of urban and rural road network, (ii) import of huge number of road vehicles from abroad involving scarce foreign exchange, (iii) neglect in maintenance and operation of the country's naturally endowed existing inland waterways transport system, and (iv) user preference of passengers to swifter and more time-saving vehicles. This resulted in diverting passengers to other modes. Notwithstanding, a recent study by Asian Development Bank makes an indicative estimate of 332 million passengers in 2020-21.

Prospect of cargo movement

Transportation of bulk cargo, POL and containers is advantageous by Inland Waterways. It is cheaper, more fuel efficient, less pollutant and environment friendly. In Bangladesh context, it has added advantages in that it generates employment for the labor class and is oriented towards serving the underprivileged and poorer sections of the population. The present growth rate during recent years is about 10% and the indicative forecast of traffic in 2020-21 is 58 million tons.

Prospect of container movement

With increasing trend of containerization all over the world, Bangladesh would not be left behind and containers began to arrive in Bangladesh in the seventies. The trend has steadily grown and today both Chittagong and Mongla ports receive containers:

Due to increased economic activity particularly in the garments sector, the overall growth scenario is encouraging.

Chittagong Port handles major share of containers reaching Bangladesh, of which 70% are known to originate from or are destined to Dhaka-Narayanganj region. Of this, major volume is transported by Roads; and less than 10% by Railways. The Dhaka-Chittagong and Dhaka-Mongla highways are already congested with traffic. Their current capacity and even by developing Dhaka-Chittagong Highway into a four-lane one, it is not expected that the highways can fully cater to the increasing number of containers. This is due to paucity of container carriers, over-congestion of traffic on highways, restrictive road curves, and inadequate bearing capacity of bridges.

Railways do not carry any containers from MonglaPort as there exist no track linking the port with rest of the country. Besides, present carrying and handling capacity of the Railways is getting saturated. Railways, already aware of the situation, is going ahead with a number of development projects which include procurement of new Container Wagons and new Locomotives as well as the construction of a new Inland Container Depot (ICD) at Dhirasram. Timely completion of these projects however depends upon availability of scarce resources and annual budget allocations. Even if fund is provided and the projects are implemented, container transport from Chittagong and Mongla ports is expected to increase by a mere 15%.

Inland waterways therefore hold great potential for container transport. A good waterway system by itself is not enough for movement of containers; proper berthing and handling facilities are required to be provided. Towards this end, an Inland Container Terminal (ICT) has already been constructed by Bangladesh Inland Water Transport Authority (BIWTA) at Pangaon on the bank of Buriganga River. Chittagong Port Authority, vested with the responsibility of initiating its operation, is going ahead with providing the handling equipment. The plan is to sail the container carrying vessels from Chittagong, de-stuff the goods at Pangaon, and transport those to their

destined business establishments. The ICT is envisaged to handle 30,000 TEUS initially; but targeted to handle 116,000 TEUS in first phase and 1,60,000 TEUS after full completion of second phase. The scheduled date of its opening is in March-April this year.

In order to further encourage transport of containers by river routes, BIWTA is nurturing a plan to open a small-scale ICT at Khanpur on the bank of Sitalakhya River on BOT basis. It has a more ambitious plan to develop another one of a larger dimension at Ashuganj on the bank of the Meghna River, which is expected to serve Bangladesh-India protocol traffic as well. Besides, the Government extended permission to private entrepreneurs to construct and operate a few more container terminals in the country. However no concrete actions in the designated sites are visible.

Containers can not be carried in any cargo ship. The vessels are required to be purpose-built specially for carrying and handling containers. Private parties are not bold enough to enter an unexplored new business field. On the other hand, Bangladesh Inland Water Transport Corporation (BIWTC), a public body showed initiative initially but their efforts could not materialize due to legal and other issues.

Present growth trend shows that there shall be no dearth of containers to be transported from the two sea-ports by IWT. The Pangaon terminal is also expected to be able to handle the same. There is therefore an urgent need for container vessels. Private parties should be encouraged to enter this prospective business arena and the Government should provide patronage by extending soft bank loans, tax holidays/ rebate, etc.

It is apparent that even though the ICT at Pangaon is completed by scheduled time, delay in procurement of suitable vessels is going to create a hurdle in proper utilization of its facilities.

4. Prospect of bangladesh-india iwt 'protocol' routes

Bangladesh with its unique geographical location is strategically located in South Asia and is in a position to serve the region by providing transit facilities to its neighbors. Under a bilateral "protocol" signed between Bangladesh and India, inter-country and transit trade using inland waterway routes in Bangladesh is already under way. The principal commodity of inter-country trade is Flyash, which has a good source of supply in Kolkata area and

ample demand in Bangladesh. The total 'protocol' freight (including Flyash) is showing an increase, indicative estimate in 2020 being 3,500 thousand tons.

Potential of bangladesh iwt in sub-regional connectivity

In 2010 Bangladesh and India signed a Joint Communique laying down a provision for using Chittagong and Mongla sea-ports by Bhutan, India and Nepal in order to promote transit trade between the countries. This led to an initial assessment of the country's transport system; and experts agreed that since the country's road network has structural and other weaknesses, most freight shall require to be carried by railways and inland waterways.

Bhutan: There exists an inland waterway route from both Chittagong and Mongla seaports upto Bangladesh border (Daikhawa, Chilmari). The waterway extends to Dhubri (India) where an important and busy river station exists. A 150 km long road in good condition exists from here to Thimpu, which is a very thriving commercial center of Bhutan.

This inland route falls within Bangladesh-India 'protocol' waterway and is also favorable for inter-country trade and for using as a transit route between India (Kolkata) to Bhutan.

Nepal: Banglabandha, a land port situated at Bangladesh boundary line, is currently in use as a crossing point for traffic and trade with Nepal. A 42 km long road runs from the border to Kakravita, a prominent and busy business hub in Nepal, However in accordance with an Agreement between India and Nepal, trucks from Nepal can come upto 'zero point' of Bangladesh border, but cannot enter into Bangladesh territory. In a similar manner, Bangladeshi trucks with export cargo are not allowed to go to Kakravita in Nepal across Indian territory. Therefore back-to-back transshipment has to be made into Indian or Nepali trucks at 'zero point'. The cumbersome transshipment operation and other unhealthy practices in no man's land are frustrating the operators; and recent port activities show a gradual decline.

There is an opportunity to extend a friendly hand to neighboring land-locked Nepal by allowing use of Bangladesh's sea-ports, its extensive waterways and land ports. Cargo destined for Nepal can be transported through Bangladesh by availing facilities in advantageously located Mongla sea-port. Incidentally, Mongla Port handled about 60,300 tons of Nepalese transit cargo in 1997-98, which fact provides a positive indication of future possibilities.

The following multi-modal routes using the country's waterways network have been identified preliminarily:

Ashuganj, Baghabari and Noapara are very prospective inland river ports that can be used as transit and transshipment points for trade with Bhutan, India and Nepal. All the three river ports are presently very active and have waterways connectivity with Chittagong and Mongla seaports and Road connectivity with numerous Land Ports situated on Bangladesh-India border. Not much investment is required to make them suitable for inter-modal transport service.

The three river ports are advantageously located in the country's waterways system and are suitable as multi-modal transshipment points for transport of containers to and from Bhutan, India and Nepal. With suitable development this service can be in addition to their routine services extended to regular passenger and cargo vessels.

Finale

In view of past low priority and comparatively meager allocations given to Inland Water Transport sector, its infrastructure has undergone drastic decline in capacity and quality. A glaring example is the cumulative reduction in length of navigable (classified) waterways of the country from 24,000 km to 6,000 km. Besides being poorly maintained the sector remains heavily under-utilized.

The construction of Jamuna and other large bridges, forthcoming PadmaBridge, import of huge number of road vehicles, and other such actions are giving unbalanced impetus upon a single mode of transport to the detriment of other modes. This is creating an unhealthy situation in the total Transport Sector leading to its uneven development, unbalanced investments, deterioration and loss of existing natural assets, traffic congestions, etc.

The prevailing situation in Transport sector is sending unfavorable signals to the inland water transport operators who are getting frustrated and may shift to more profitable business ventures. This does not augment well for the country as this will lead to further deterioration of the country's naturally gifted inland waterways.

Effect of PadmaBridge: The construction of PadmaBridge is expected to change the existing overall traffic pattern of the country, particularly that of the South-West region. Berthing and handling density may shift from some river ports to others due to changed scenario. Bulk cargo and POL, because of their intrinsic character, shall continue to be transported by the waterways.

Completion of a container handling terminal at Pangaon though belated is a great leap forward. Augmentation of facilities in existing inland river ports, particularly those at Ashuganj, Baghabari and Noapara is likely to encourage goods movement significantly. Such and similar actions are likely to improve existing water-borne traffic and pave the way for multi-modal cargo and container movement. Bangladesh with its naturally endowed waterways network is strategically located in South Asia and can contribute towards raising the living standard of the region's people by providing transit facilities to its neighboring countries, Bhutan, India and Nepal.

The potential of the country's waterways remain untapped; its prospects are yet to be exploited. What is required now is a determined political will to set priorities properly considering the country's present needs and future aspirations. The immediate aim should be to arrest further damage to the country's waterways transport system and maintain it, at the least, at its present level.

Chapter 9: Conclusion

The project consist a hope for all of us. We hope that through our project we have tried to help those passengers to give them a small safety during their journey. We hope that this system will help driver to avoid any kind of accidents and risk of losing life or property. If we can ensure the safety of people the water vehicles system will be the safest transport system of Bangladesh. Though we know that the image of Bangladesh is very low because of high rate of accidents but we hope that someday we will able to prevent it and increase a good image of Bangladesh.

BRAC
UNIVERSITY



Chapter 10: reference

[1] **Transport, Banglapedia publishes the water transportation in Bangladesh.**

[2] Bangladesh index, Bangladesh-Inland Waterways and Ports TRANSPORTATION AND COMMUNICATION, publishes in Mongabay.com

[3] **Water transport, BANGLAPEDIA NATIONAL ENCYCLOPEDIA BANGLADESH publishes by** AKM Nurul Alam

[4] **River port,** publishes by Fazilatun Nesa and AKM Khademul Haque.

[5] **Collision** of marine vehicles in Bangladesh: a study on accident characteristics publishes by ,

[Zobair Ibn Awal](#), (Accident Research Institute (ARI), Bangladesh University of Engineering and Technology (BUET), Dhaka, Bangladesh), [M. Rafiqul Islam](#), (Faculty of Mechanical Engineering, Universiti Teknologi Malaysia (UTM), Skudai, Malaysia), [Md Mazharul Hoque](#), (Accident Research Institute (ARI) and Department of Civil Engineering, Bangladesh University of Engineering and Technology (BUET), Dhaka, Bangladesh)

[6] Ultrasonic Ranging Module HC - SR04, publishes on ELEC FREAKS.

[7] **Robotics and Automation,** [Dunbabin, M.](#) Autonomuos Syst. Lab., CSIRO ICT Centre, Kenmore, QLD, publishes on 19-23 May 2008

[8] [http://www.dhakachamber.com/economic_policy/Transportation AirWaterLand.pdf](http://www.dhakachamber.com/economic_policy/Transportation_AirWaterLand.pdf) [last date of excess: march 25,2014]

[9] MohammedC, "Bangladesh inland water transport," may 4,2008.

[10] Article- MSC Preziosa urta finger, polemica a Venezia, Cruise and Ferries, The meditelegraph, April 05,2014.

[11] A brief description of the radar approach equipment of the Soyuz-type spacecraft ("Kratkoye opisaniye radioapparatury sblisheniya kosmicheskikh korablya tipa Soyuz"), NASA Technical translation, Washington D.C. ,1970. (available starting at page 23 of <http://history.nasa.gov/astp/APSYZ-descharac3.PDF>)

[12] Burrough, Bryan (1998). [*Dragonfly: NASA and the Crisis Aboard Mir*](#). Fourth Estate. p. 65. [ISBN 0-06-093269-4](#). "Since 1985 all Russian spacecraft had used the Kurs computers to dock automatically with the Mir station [...] All the Russian commanders had to do was sit by and watch."

[13] [National Space Agency of Ukraine / Kurs Research and Production Complex, Public Company](#)

[14] Hinman, Elaine M; Bushman, David M. (1991). *Executive Summary*. "Soviet automated rendezvous and docking system overview". *NASA Automated Rendezvous and Capture Review*.: 34–35. [Bibcode:1991arcr.nasa...34H](#). "IGLA system was replaced with the current KURS system. Both systems are radar-based. [...] the docking process can be controlled either from the ground or from the active (docking) spacecraft's onboard computer. [...] Soyuz TM and Progress M Series spacecraft incorporated the KURS. The MIR Complex has both systems installed."

[15] [Linenger, Jerry](#) (January 1, 2001). [*Off the Planet: Surviving Five Perilous Months Aboard the Space Station Mir*](#). New York, USA: McGraw-Hill. [ISBN 978-0-07-137230-5](#)

[16] [NASA Docking System \(NDS\) Technical Integration Meeting \(2010-11-17\)](#)

[17] Parma, George (2011-05-20). ["Overview of the NASA Docking System and the International Docking System Standard"](#). NASA. Retrieved 11 April 2012.

Chapter 11: Appendix

Code -

```
/*  
LiquidCrystal Library - Hello World  
*/  
  
// include the library code:  
#include <Servo.h>  
#include <LiquidCrystal.h>  
  
// initialize the library with the numbers of the interface pins  
LiquidCrystal lcd(0, 1, 2, 3, 4, 5);  
  
// sonar module definitions  
const byte Sonar1_Trig = 6;  
const byte Sonar1_Echo = 7;  
unsigned int Sonar1_Distance_cm = 0;  
const byte Sonar2_Trig = 8;  
const byte Sonar2_Echo = 9;  
unsigned int Sonar2_Distance_cm = 0;  
  
// servo module definitions  
// create servo object to control a servo  
// a maximum of eight servo objects can be created  
Servo Servo1;  
const byte Servo1_Pin = 12;  
  
// dc motor definitions  
const byte Motor1_Pin = 13;  
  
void setup()  
{  
  // init sonar 1 i/o  
  pinMode(Sonar1_Trig, OUTPUT);  
  digitalWrite(Sonar1_Trig, LOW);  
}
```

```

// init sonar 2 i/o
pinMode(Sonar2_Trigger, OUTPUT);
digitalWrite(Sonar2_Trigger, LOW);

// init motor 1 i/o
pinMode(Motor1_Pin, OUTPUT);
digitalWrite(Motor1_Pin, HIGH);

// set up the LCD's number of columns and rows:
lcd.begin(16, 2);

// Print a message to the LCD.
lcd.print("AutoShipDocking ");

// attaches the servo to the servo object
Servo1.attach(Servo1_Pin);

// init servo to middle position
Servo1.write(90);
}

byte pos = 0, dir = 0;
void loop()
{
// measure distance
GetSonarDistance();

// show result
// left sensor
lcd.setCursor(0, 1);
lcd.print("L:  ");
lcd.setCursor(2, 1);
lcd.print(Sonar1_Distance_cm);
lcd.print("cm");

// right sensor
lcd.setCursor(9, 1);
lcd.print("R:  ");

```

```

lcd.setCursor(11 , 1);
lcd.print(Sonar2_Distance_cm);
lcd.print("cm");

// control motor 1
if(Sonar1_Distance_cm <= 10 && Sonar2_Distance_cm <= 10)
{
digitalWrite(Motor1_Pin, LOW);
}
else
{
digitalWrite(Motor1_Pin, HIGH);
}

// tell servo to go to position in variable 'pos'
if(Sonar1_Distance_cm < 50)
{
Servo1.write(90 + 45);
}
else if(Sonar2_Distance_cm < 50)
{
Servo1.write(90 - 45);
}
else
{
Servo1.write(90);
}

// give a small delay
delay(100);
}

voidGetSonarDistance()
{
// establish variables for duration of the ping,
// and the distance result in inches and centimeters:
unsignedint duration;

/*

```



```

* SONAR 1 Measurement
*/
// The PING))) is triggered by a HIGH pulse of 10 or more microseconds.
// Give a short LOW pulse beforehand to ensure a clean HIGH pulse:
digitalWrite(Sonar1_Trig, HIGH);
delayMicroseconds(10);
digitalWrite(Sonar1_Trig, LOW);

// a HIGH pulse whose duration is the time (in microseconds) from the
sending
// of the ping to the reception of its echo off of an object.
duration = pulseIn(Sonar1_Echo, HIGH);

// convert the time into a distance
// Formula: uS / 58 = centimeters
Sonar1_Distance_cm = duration / 58;

/*
* SONAR 2 Measurement
*/
// The PING))) is triggered by a HIGH pulse of 10 or more microseconds.
// Give a short LOW pulse beforehand to ensure a clean HIGH pulse:
digitalWrite(Sonar2_Trig, HIGH);
delayMicroseconds(10);
digitalWrite(Sonar2_Trig, LOW);

// a HIGH pulse whose duration is the time (in microseconds) from the
sending
// of the ping to the reception of its echo off of an object.
duration = pulseIn(Sonar2_Echo, HIGH);

// convert the time into a distance
// Formula: uS / 58 = centimeters
Sonar2_Distance_cm = duration / 58;
}

```

